

(12) **United States Patent**  
**Earhart et al.**

(10) **Patent No.:** **US 10,557,247 B2**  
(45) **Date of Patent:** **Feb. 11, 2020**

(54) **REINFORCEMENT UNIT AND METHODS FOR CREATING A FOOTING FOR SUPPORTING A STRUCTURE**

3,611,952 A \* 10/1971 Hoffman ..... B65D 19/004  
108/11

(Continued)

(71) Applicant: **Glen Raven, Inc.**, Glen Raven, NC (US)

FOREIGN PATENT DOCUMENTS

(72) Inventors: **Robert Charles Earhart**, Mebane, NC (US); **Matthew Landon Clark**, Whitsett, NC (US)

JP 2000-282714 A 10/2000  
JP 2002357019 A 12/2002

(73) Assignee: **Glen Raven, Inc.**, Glen Raven, NC (US)

OTHER PUBLICATIONS

(\* ) Notice: Subject to any disclaimer, the term of this patent is extended or adjusted under 35 U.S.C. 154(b) by 168 days.

International Search Report and Written Opinion of the International Searching Authority, International Application No. PCT/US2018/031134, dated Sep. 27, 2018, 12 pp.

(21) Appl. No.: **15/685,354**

*Primary Examiner* — Chi Q Nguyen

(22) Filed: **Aug. 24, 2017**

(74) *Attorney, Agent, or Firm* — Myers Bigel, P.A.

(65) **Prior Publication Data**

US 2018/0327995 A1 Nov. 15, 2018

**Related U.S. Application Data**

(60) Provisional application No. 62/506,030, filed on May 15, 2017.

(51) **Int. Cl.**  
**E02D 27/00** (2006.01)  
**E02D 27/42** (2006.01)

(Continued)

(52) **U.S. Cl.**  
CPC ..... **E02D 27/42** (2013.01); **E04H 12/22** (2013.01); **E04H 12/2269** (2013.01);

(Continued)

(58) **Field of Classification Search**  
CPC ..... E02D 27/42; E02D 27/00; E02D 27/08; E02D 27/16; E02D 2300/0053;

(Continued)

(56) **References Cited**

U.S. PATENT DOCUMENTS

3,598,065 A \* 8/1971 Young ..... B65D 19/0028  
108/3

(57) **ABSTRACT**

A reinforcement unit and methods are provided for creating footings for supporting structures, such as a fence post, using a reinforcement unit that has a tower that is generally perpendicular to a base, the tower defining a cavity for receiving a portion of the structure and an anchoring material. The reinforcement unit can include a top portion of a tower that is frangible. The base of the reinforcement unit can further include a pocket (or similar recess) substantially similar in width or diameter to the top portion of the tower such that a second identical reinforcement unit can be inverted and stacked on top of the second reinforcement unit. The methods can include placing the reinforcement unit on a layer of backfill material behind the wall face so that the unit is located adjacent the wall face and the base of the reinforcement unit extends away from the wall face, covering the base with at least one other layer of the backfill material, fracturing the top portion from the tower, such that the top portion drops into the cavity of the tower, depositing a bottom portion of the structure in the cavity of the tower, and filling the cavity of the tower with an anchoring material.

**8 Claims, 8 Drawing Sheets**

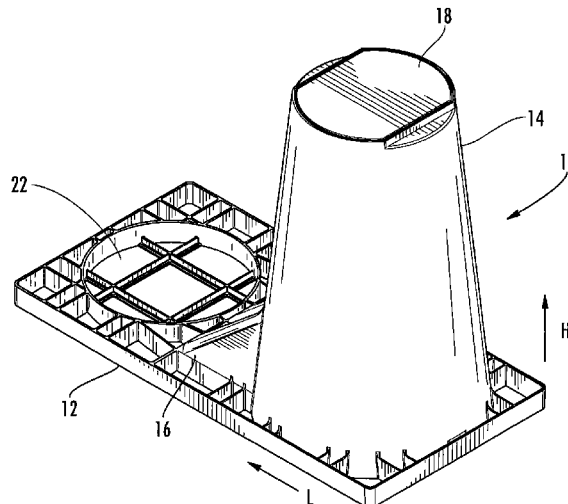

# US 10,557,247 B2

Page 2

- |      |   |  |  |  |  |
|------|---|--|--|--|--|
| (51) | <b>Int. Cl.</b><br><i>E04H 12/22</i> (2006.01)<br><i>E04H 17/22</i> (2006.01)<br><i>E04H 17/08</i> (2006.01)  | 6,802,668 B2 *<br>7,549,259 B2<br>7,562,502 B2<br>7,874,122 B2<br>7,987,797 B2 *                       | 10/2004<br>6/2009<br>7/2009<br>1/2011<br>8/2011      | Parker .....<br>Calle<br>Calle<br>Calle<br>Stahl .....                         | E02D 31/02<br>405/49<br><br>B65D 19/004<br>108/53.3<br>G09B 23/30<br>434/262                           |
| (52) | <b>U.S. Cl.</b><br>CPC ..... <i>E04H 17/08</i> (2013.01); <i>E04H 17/22</i><br>(2013.01); <i>E02D 2300/0007</i> (2013.01); <i>E02D</i><br><i>2300/0053</i> (2013.01)  | 8,162,668 B2 *   | 4/2012   | Toly .....   | A47B 91/005<br>108/51.11<br>B65D 19/0018<br>108/53.3<br>E02B 11/00<br>52/169.5<br>E02D 27/42<br>52/297 |
| (58) | <b>Field of Classification Search</b><br>CPC .... <i>E02D 2300/0059</i> ; <i>E02D 2300/0007</i> ; <i>E02D</i><br><i>2300/001</i> ; <i>E04H 12/22</i> ; <i>E04H 12/2253</i> ;<br><i>E04H 12/2238</i> ; <i>E04H 12/2269</i><br>USPC ..... 52/297, 155, 704, 292, 296, 298;<br>248/507, 530<br>See application file for complete search history. | 8,708,304 B2 *<br><br>2002/0017225 A1 *<br>2003/0200708 A1 *<br>2011/0061321 A1 *<br>2012/0255624 A1 * | 4/2014<br><br>2/2002<br>10/2003<br>3/2011<br>10/2012 | Dysinger .....<br>Koefeld .....<br>Parker .....<br>Phuly .....<br>Canney ..... | A47B 91/005<br>B65D 19/0018<br>108/53.3<br>E02B 11/00<br>E02D 27/42<br>E02B 11/005<br>137/315.01       |
| (56) | <b>References Cited</b><br>U.S. PATENT DOCUMENTS<br><br>3,699,901 A * 10/1972 Cook, III ..... B65D 19/004<br>108/55.5<br>5,755,162 A * 5/1998 Knight ..... B65D 19/0012<br>108/53.1   | <br>2014/0231737 A1<br>2014/0291221 A1 *<br><br>2017/0022730 A1<br>2017/0030104 A1                     | <br>8/2014<br>10/2014<br><br>1/2017<br>2/2017        | Whiteley<br>Adams .....<br><br>Mansueto<br>Sinclair                            | E03F 1/005<br>210/170.03   |

\* cited by examiner

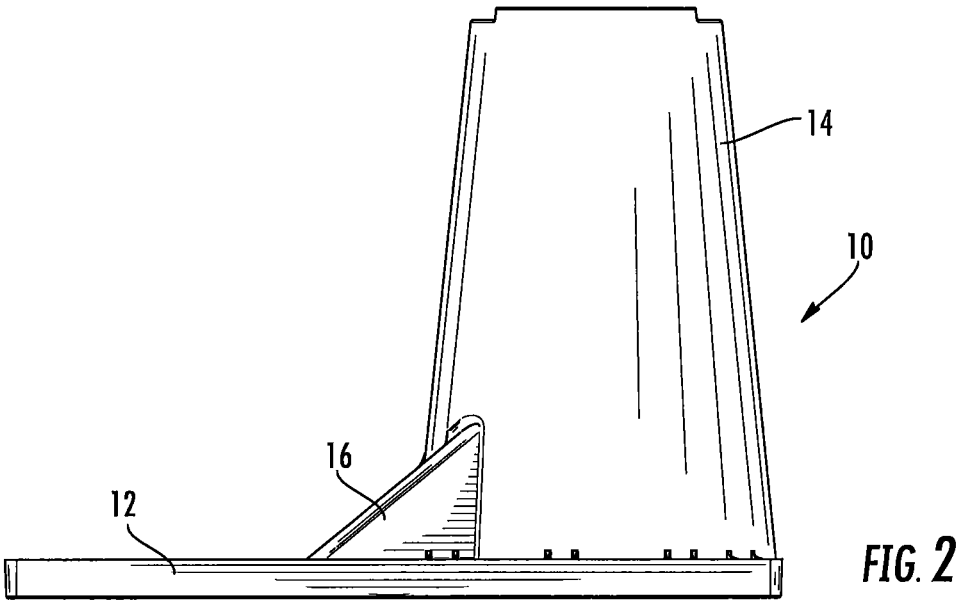
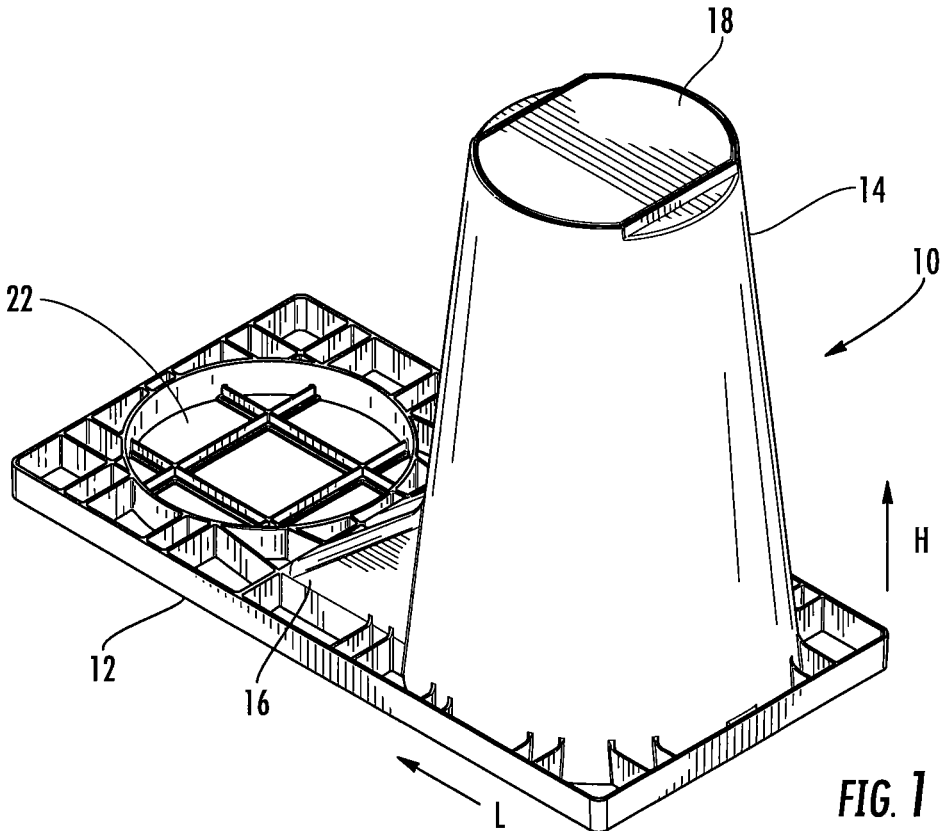

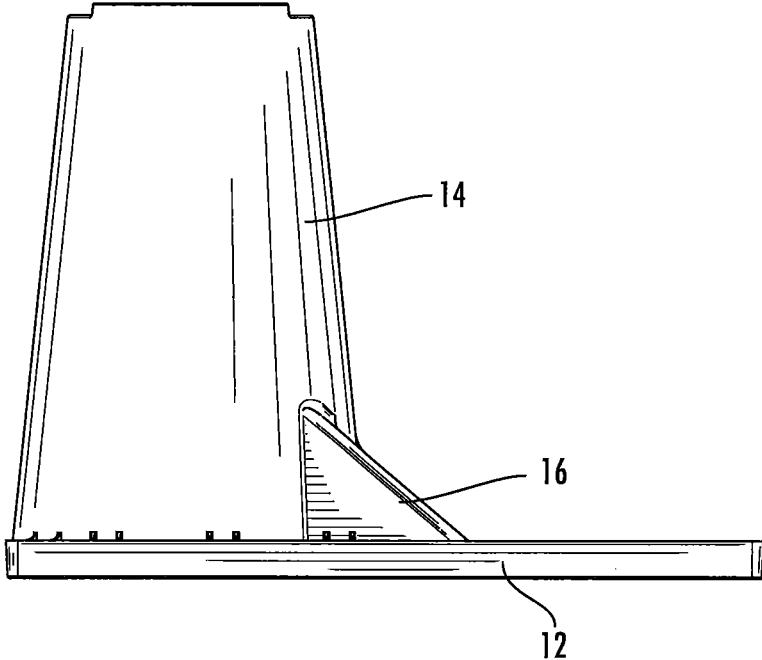

FIG. 3

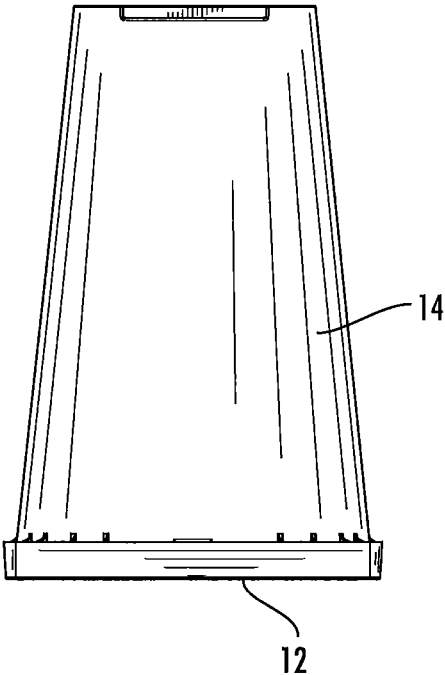

FIG. 4

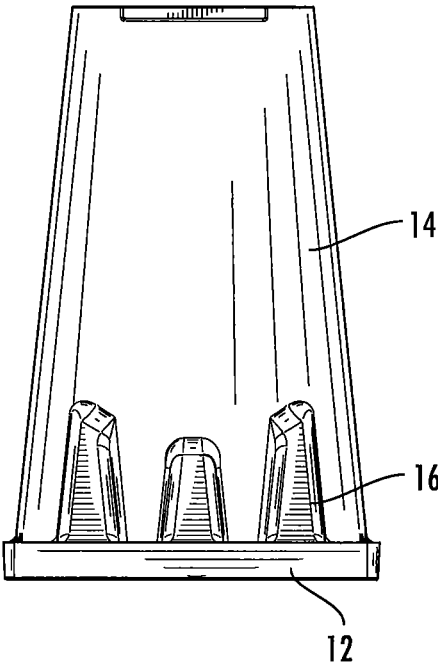

FIG. 5

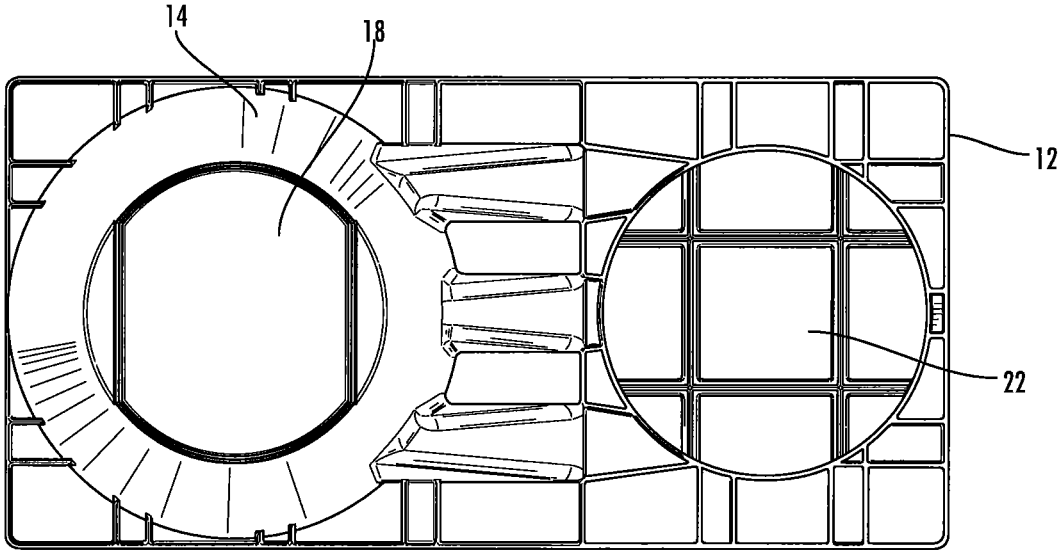

FIG. 6

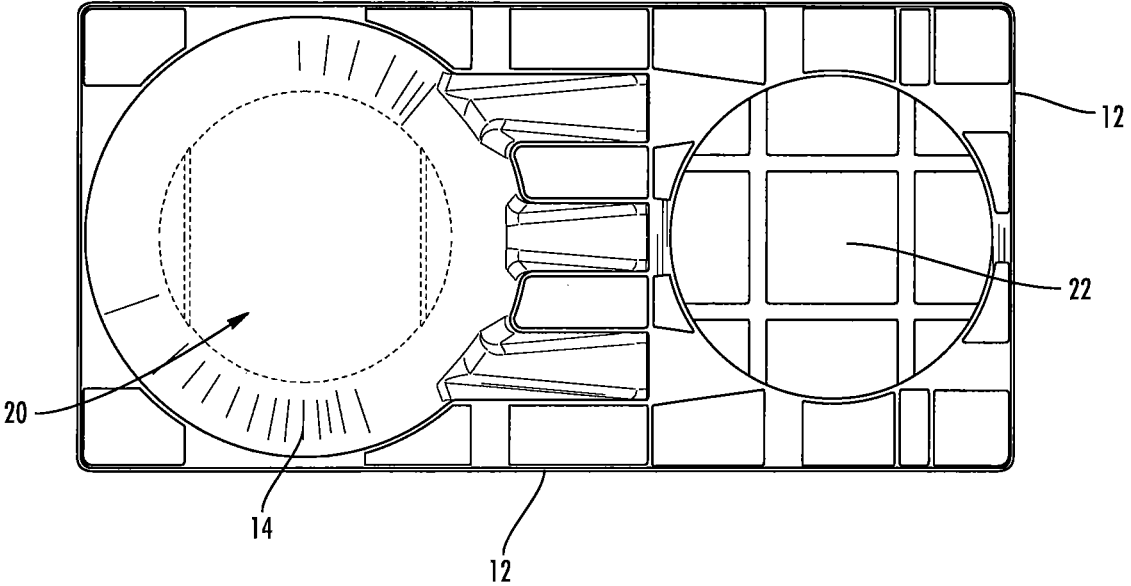

FIG. 7

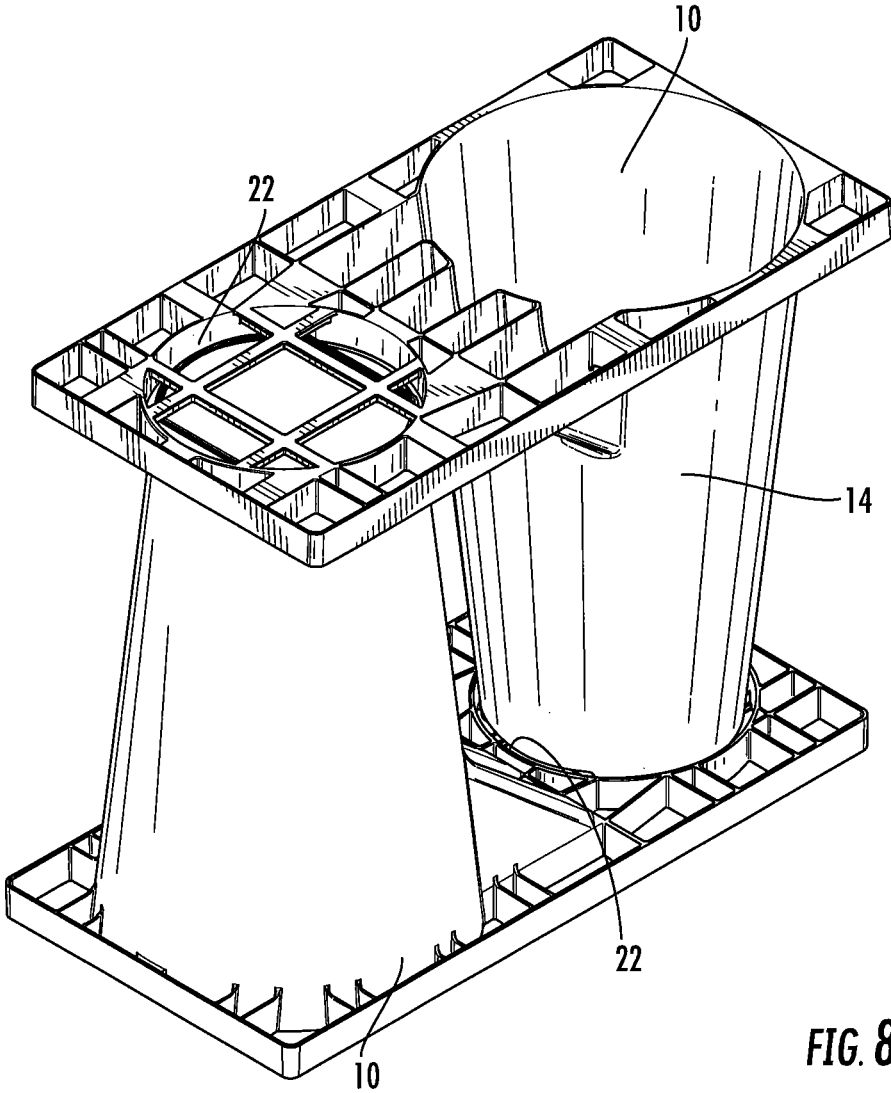

FIG. 8

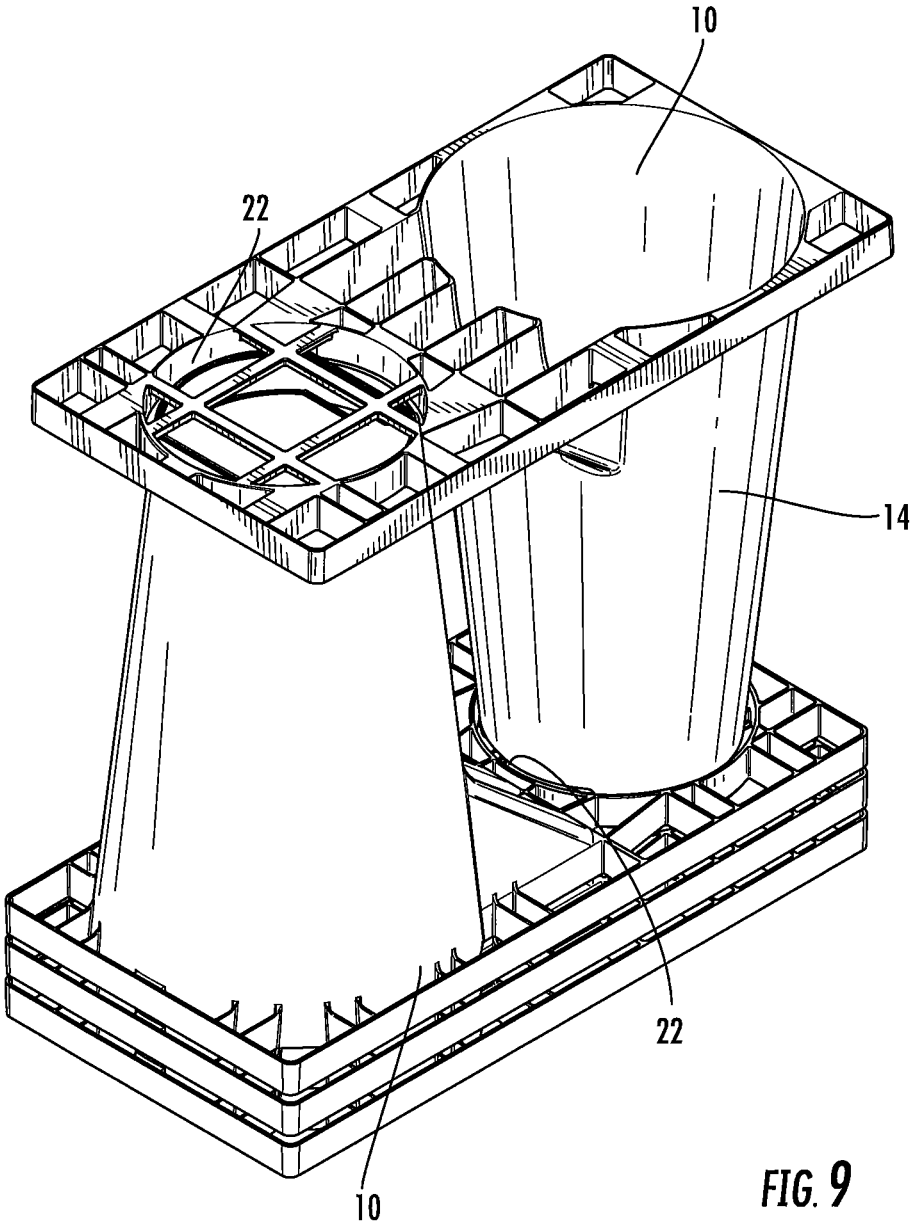
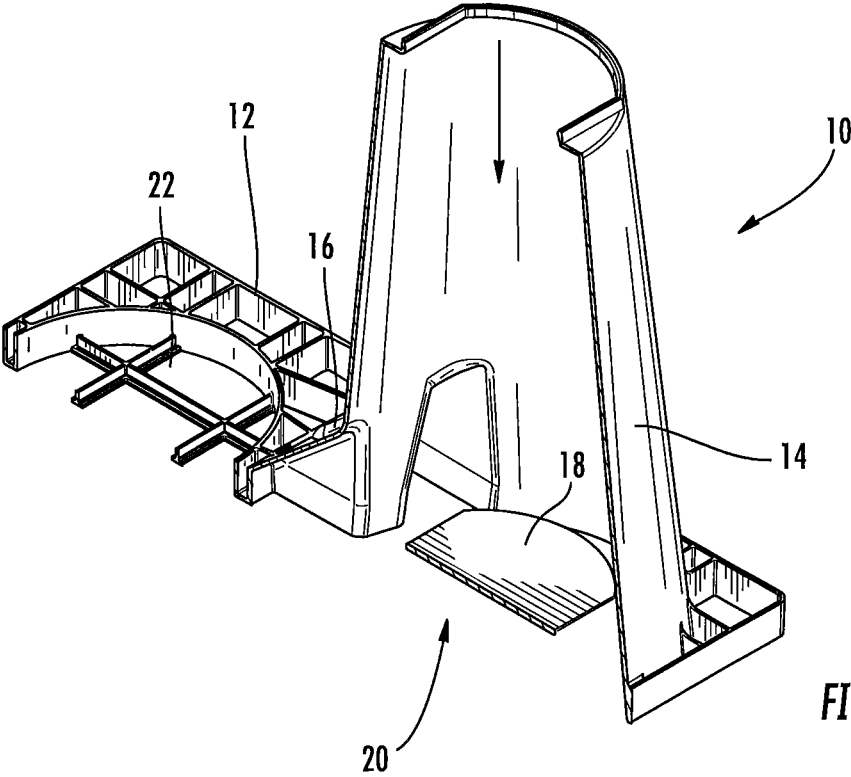
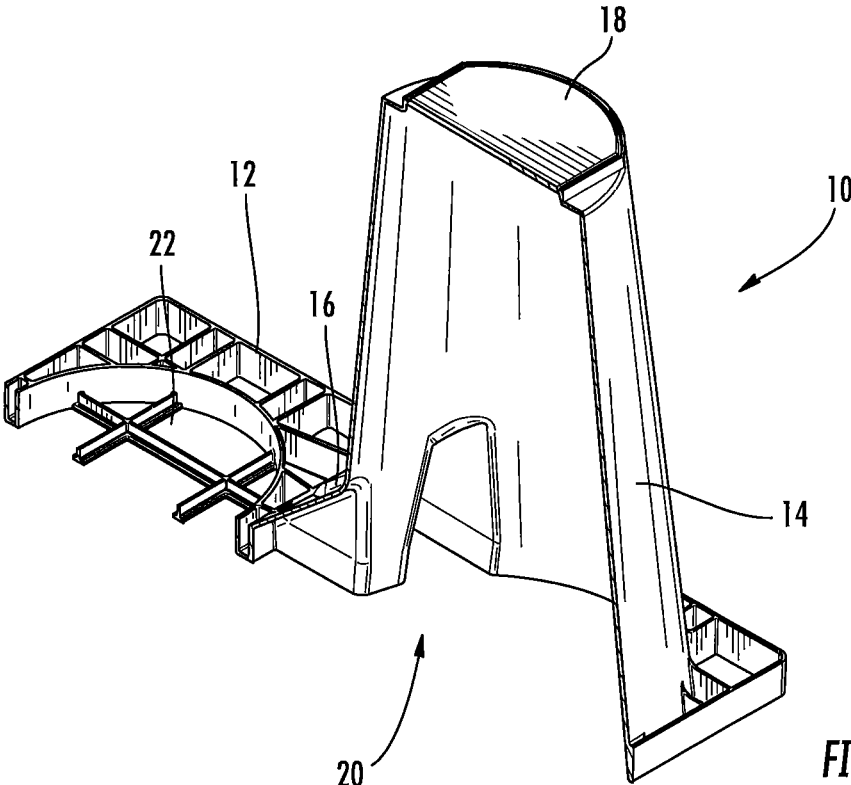

FIG. 9





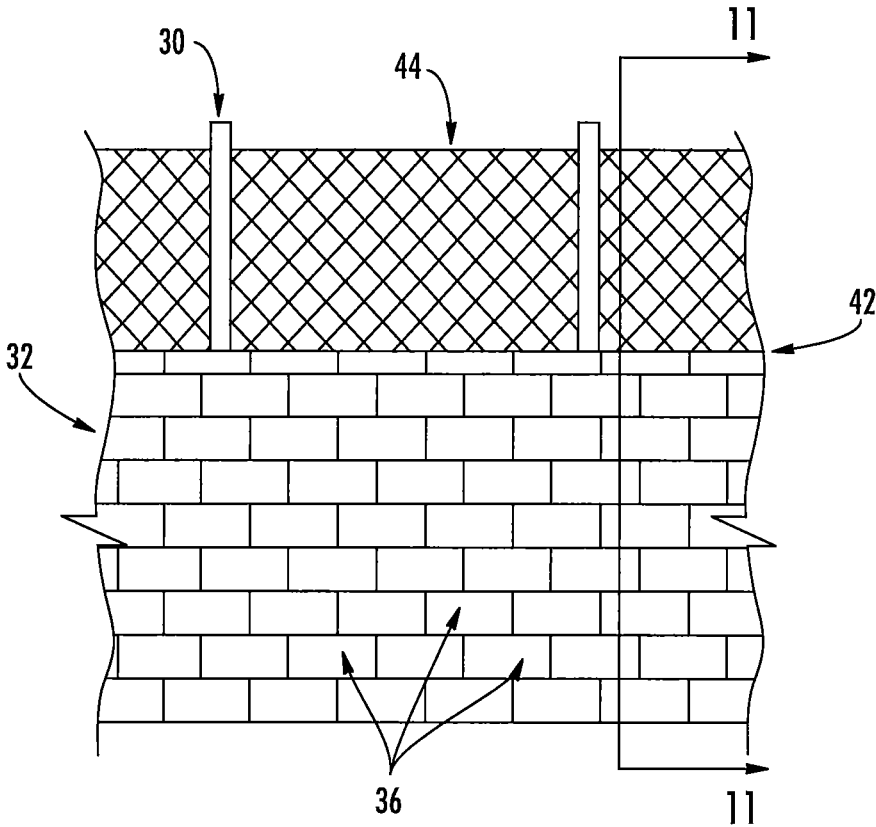

FIG. 12

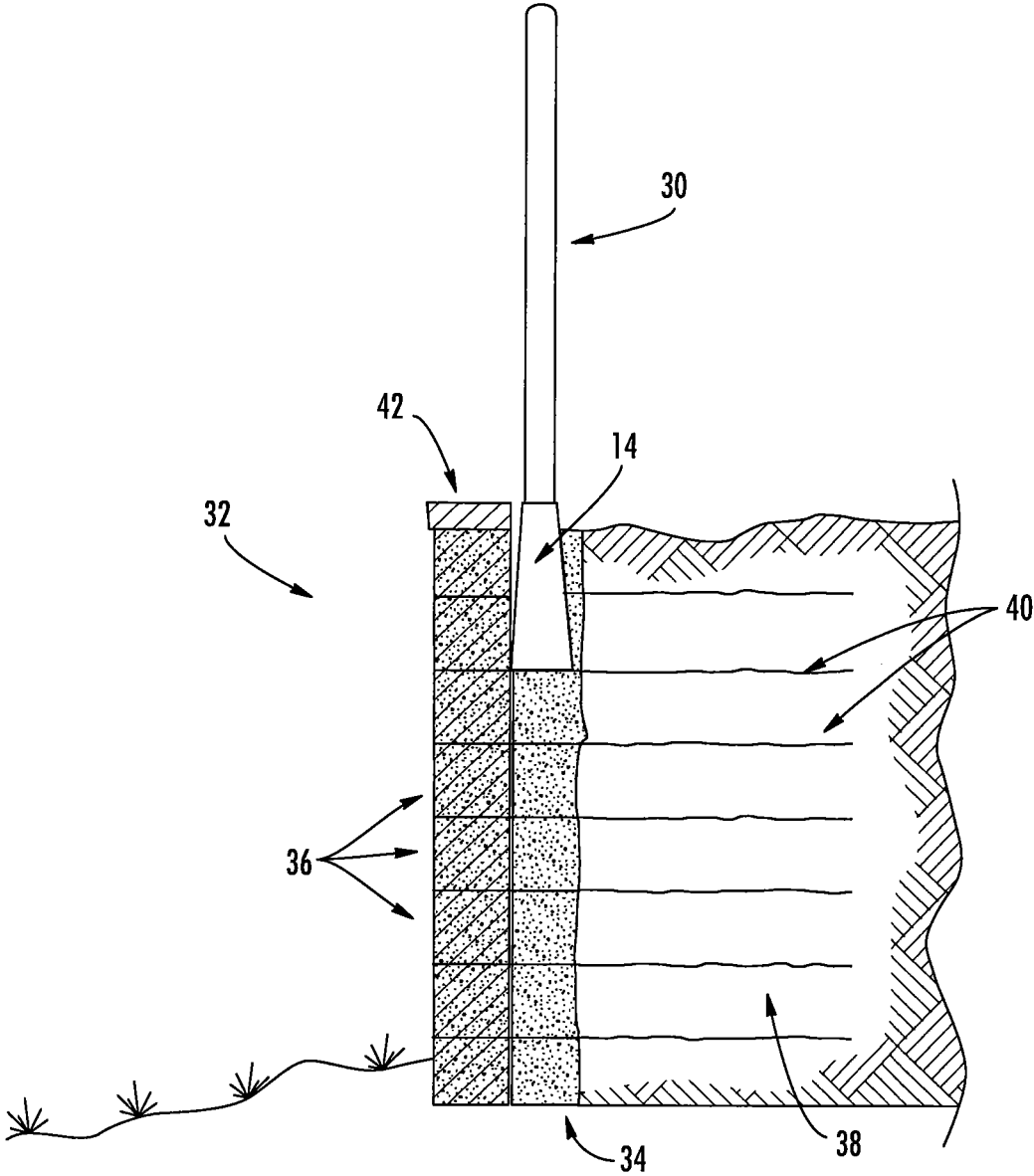

FIG. 13

1

## REINFORCEMENT UNIT AND METHODS FOR CREATING A FOOTING FOR SUPPORTING A STRUCTURE

### RELATED APPLICATION

The present application claims priority from and the benefit of U.S. Provisional Patent Application No. 62/506,030, filed May 15, 2017, the disclosure of which is hereby incorporated by reference herein in its entirety.

### FIELD OF THE INVENTION

The present invention is directed to a reinforcement unit and methods for creating footings for supporting structures such as fence posts.

### BACKGROUND OF THE INVENTION

Segmental retaining walls are commonly used in both residential and commercial applications to create usable real estate. Fencing is often required behind such walls to reduce the potential for falls and other potential hazards. In addition, guardrails usually are required in applications where parking lots or roadways are located near top of the wall.

Fence posts typically are mounted using concrete footings. A concrete footing can be created by digging a cavity in the ground, placing a bottom portion of the fence post in the cavity, and pouring concrete into the cavity.

Segmental retaining walls often include a reinforcing tie back system. For example, multiple layers of geosynthetic soil reinforcing material (commonly referred to as "geogrid") can be secured to the wall face so that the layers extend horizontally into the surrounding stone or soil. The interaction between the stone or soil and the reinforcing material can help to stabilize the wall face, i.e., the portion of the wall formed by stacked concrete blocks.

Digging a cavity for a fence post footing near a segmental retaining wall, after the reinforcing material has been installed, can necessitate drilling through the reinforcing material. Drilling through the reinforcing material can adversely affect the integrity of the reinforcing material, and therefore is undesirable. Hence, the cavities for fence posts located near segmental retaining walls are usually created as the wall is constructed.

In one approach, fence post cavities can be created using cylindrical cardboard forms. These forms usually are provided in relatively long lengths, and therefore must be cut to a desired length at the installation site. The form is placed on the backfill material (typically soil) used behind that wall, as the backfill material reaches a predetermined height. The predetermined height is chosen so that the top of the form is exposed from above ground after the wall has been completed, and all backfill material has been introduced and compacted. The form defines an open cavity in the ground that can receive the fence post.

The soil used as backfill material is usually kept moist, to help to achieve maximum density during compacting. Cardboard forms can be adversely affected by such moisture. Moisture from precipitation also can affect the integrity of a cardboard form. Also, the loads on the cardboard form resulting from the compacted backfill material, if excessive, can cause the form to collapse.

Alternatively, the form used to create the cavity can be created by cutting a predetermined length of polyvinyl chloride (PVC) or high-density polyethylene (HDPE) pipe. These materials are usually delivered to the installation site

2

in ten or twenty-foot lengths. The need to cut the pipe creates an additional step in the construction process for the wall. Moreover, installers often cut the pipe using concrete demolition saws, chain saws, and other tooling not made for this particular use, thereby creating a potential safety hazard.

The cavity defined by the form creates a potential for injuries resulting from tripping over or stepping into an open hole in the ground. Moreover, the open cavity can fill with dirt and other debris, particularly in installations where fence posts will not be installed immediately after completion of the segmental retaining wall.

To reduce some of these potential issues, prior footing designs include a cover that protects the cavity. However, the cover must be removed prior to the fence post being installed. One example is discussed in U.S. Pat. No. 7,874,122 to Calle, the disclosures of which is hereby incorporated herein by reference. These covers are constantly lost on jobsites and/or create unwanted waste once removed.

A more efficient design for packaging, shipping and storage is also desired.

### SUMMARY OF THE INVENTION

As a first aspect, embodiments of the present invention are directed to a reinforcement unit for creating a footing for supporting a structure, comprising: a base extending in a first direction; and a tower extending in a second direction from a first end of the base that is generally perpendicular to said base, a top portion of the tower having a width or a diameter smaller than the width or diameter of a bottom portion of the tower, the tower defining a cavity for receiving a portion of the structure and an anchoring material, wherein the portion of the structure is inserted into the cavity by way of a top of the cavity, and a width or a diameter of the top of the cavity is substantially greater than the outer dimensions of the portion of the structure so that the anchoring material can be introduced into the cavity by way of the top of the cavity while the portion of the structure is positioned within the cavity, wherein a second end of the base comprises a pocket substantially similar in width or diameter to the top portion of the tower such that a second identical reinforcement unit can be inverted and stacked on top of the reinforcement unit.

As a second aspect, embodiments of the present invention are directed to a reinforcement unit for creating a footing for supporting a structure, comprising: a base extending in a first direction; and a tower extending in a second direction from a first end of the base that is generally perpendicular to the base, a top portion of the tower having a width or a diameter smaller than the width or diameter of a bottom portion of the tower, the tower defining a cavity for receiving a portion of the structure and an anchoring material, wherein the portion of the structure is inserted into the cavity by way of a top of the cavity, and a width or a diameter of the top of the cavity is substantially greater than the outer dimensions of the portion of the structure so that the anchoring material can be introduced into the cavity by way of the top of the cavity while the portion of the structure is positioned within the cavity, and wherein the top portion of the tower comprises a frangible section.

As a third aspect, embodiments of the present invention are directed to a method for creating a footing for supporting a structure using a reinforcement unit comprising a tower that is generally perpendicular to a base, the tower defining a cavity for receiving a portion of the structure and an anchoring material, and wherein a top portion of the tower comprises a frangible section, the method comprising: placing the reinforcement unit on a layer of backfill material

behind a wall face so that the tower is located adjacent the wall face and the base extends away from the wall face; covering the base of the reinforcement unit with at least one other layer of the backfill material; fracturing the top portion from the tower, such that the top portion drops into the cavity of the tower; depositing a bottom portion of the structure into the cavity of the tower; and filling the cavity of the tower with an anchoring material.

#### BRIEF DESCRIPTION OF THE FIGURES

FIG. 1 is a perspective view of a reinforcement unit useful in creating footings for supporting a structure according to embodiments of the present invention.

FIG. 2 is a left side view thereof.

FIG. 3 is a right side view thereof.

FIG. 4 is a front view thereof.

FIG. 5 is a rear view thereof.

FIG. 6 is a top view thereof.

FIG. 7 is a bottom view thereof.

FIG. 8 is a perspective view of two reinforcement units of FIG. 1, wherein one of the reinforcement units is inverted, the two reinforcement units in a stacked configuration suitable for shipping.

FIG. 9 is a side view of multiple reinforcement units of FIG. 1 in a stacked configuration suitable for shipping.

FIG. 10 is a cross-sectional view of the reinforcement unit of FIG. 1.

FIG. 11 is a cross-section view of the reinforcement unit of FIG. 1, wherein the cover has been separated from the tower and has fallen into the cavity.

FIG. 12 is a side view of a wall, and a fence having fence post footings supported using the reinforcement unit shown in FIG. 1.

FIG. 13 is a cross-sectional view of a wall, and a fence shown in FIG. 12.

#### DETAILED DESCRIPTION OF THE INVENTION

The present invention will be described more particularly hereinafter with reference to the accompanying drawings. The invention is not intended to be limited to the illustrated embodiments; rather, these embodiments are intended to fully and completely disclose the invention to those skilled in this art. In the drawings, like numbers refer to like elements throughout. Thicknesses and dimensions of some components may be exaggerated for clarity.

Unless otherwise defined, all terms (including technical and scientific terms) used herein have the same meaning as commonly understood by one of ordinary skill in the art to which this invention belongs. It will be further understood that terms, such as those defined in commonly used dictionaries, should be interpreted as having a meaning that is consistent with their meaning in the context of the relevant art and will not be interpreted in an idealized or overly formal sense unless expressly so defined herein.

The terminology used herein is for the purpose of describing particular embodiments only and is not intended to be limiting of the invention. As used herein, the singular forms “a”, “an”, and “the” are intended to include the plural forms as well, unless the context clearly indicates otherwise. It will be further understood that the terms “comprises” and/or “comprising”, when used in this specification, specify the presence of stated features, integers, steps, operations, elements, and/or components, but do not preclude the presence or addition of one or more other features, integers, steps,

operations, elements, components, and/or groups thereof. As used herein the expression “and/or” includes any and all combinations of one or more of the associated listed items.

Referring now to the figures, a reinforcement unit **10** for creating a footing for supporting a structure, such as a fence post, is illustrated in FIGS. 1-13. The reinforcement unit **10** is described herein in connection with a fence post **30**. This particular application is described for exemplary purposes only. The reinforcement unit **10** can be used to construct footings for other types of structures and structural components, such as, but not limited to, light posts, sign posts, guard rail posts, etc. As used herein, the term “structure” is intended to encompass structures and structural components.

The reinforcement unit **10** comprises a base **12** and a tower **14**. The base **12** extends in a first direction (L) and the tower **14** extends in a second direction (H) that is generally perpendicular to the base **12**. The reinforcement unit **10** may comprise a plurality of reinforcing members **16** attached to the base **12** and the tower **14**. These components are described in greater detail below.

The tower **14** defines a cavity **20** (FIG. 7) for receiving a portion of the structure (such as a fence post) that is being supported and an anchoring material. The top portion of the tower **14** has a width or a diameter that is smaller than the width or diameter of the bottom portion of the tower **14**. The diameter of the main portion of the tower **14** should be sufficient to permit the main portion of the tower **14** to accommodate the lower portion of the structure that is being supported, e.g., the fence post **30**. The optimal length of the main portion of the tower **14** is application-dependent, and can vary with factors such as the amount of force the reinforcement unit **10** needs to produce to counteract bending moments and linear forces on the fence post **30**. In some embodiments, the tower **14** is frusto-conical in shape. In alternative embodiments, the tower **14** can have a shape other than frusto-conical, such as cylindrical, rectangular, or the like.

The top portion of the tower **14** may comprise a cover **18**. In some embodiments, the cover **18** may be manufactured as a single piece with the tower **14**. In alternative embodiments, the cover **18** may be a manufactured as a separate piece. In some embodiments, to facilitate relatively easy separation of the cover **18** from the upper end of the tower **14**, the top portion of the tower **14** comprises a frangible section that can break away from the remainder of the tower **14** (FIG. 11). A frangible cover **18** may be attached to the tower **14** via thinned sections, scored sections, discontinuous sections, or the like, that enable it to be easily fractured or broken away from the remainder of the tower **14**.

As noted above, the base **12** extends from the tower **14** in a direction (L) substantially perpendicular to the longitudinal axis (H) of the tower **14**, i.e., the base **12** and the tower **14** are separated by an angle of approximately ninety degrees. At a section of the base **12** opposite the tower **14** is a pocket **22** (or similar recess). The pocket **22** is substantially similar in width or diameter to the top portion of the tower **14**. The size and shape of the base **12** can vary and are application-dependent (for example, the base **12** need not be rectangular). The optimal dimensions of the base **12** can vary with factors such as the amount of force the reinforcement unit **10** needs to produce to counteract external forces on the fence post **30**. In some embodiments, the base **12** comprises a grid pattern.

As can be seen in FIGS. 2 and 6, the reinforcing members **16** provide the tower **14** with additional support. The reinforcing members **16** may be formed from the same composition as the base **12** and the tower **14**; as such, the compo-

sition should have suitable strength to withstand the forces exerted thereon by the fence post **30** and any backfill material **34** placed around the reinforcement unit **10** during installation. In some embodiments, the base **12**, the tower **14**, and the reinforcing members **16** form a monolithic component.

The aforementioned pocket **22** may be included to enable a second identical reinforcement unit **10** which can be inverted and stacked on the first reinforcement unit **10**. FIG. **8** illustrates how two identical reinforcement units **10** can be stacked on one another, saving space during shipping, thereby allowing the reinforcement unit **10** to be shipped in a relatively space-efficient manner. Stacking the reinforcement units **10** in this manner also creates a flat surface allowing additional items to be stacked on top of the reinforcement units **10** during packaging.

FIG. **9** illustrates how multiple reinforcement units **10** can also be stacked on top of one another, further saving space during shipping.

Moreover, the inclusion of the frangible cover **18** of the tower **14** can eliminate the problem of lost covers at jobsites and also can facilitate less waste. More specifically, the frangible cover **18** can be punched downwardly; as the cover **18** breaks away, it falls into the cavity **20** of the tower **14**, which is subsequently filled with anchoring material. FIG. **11** illustrates the cover **18** falling into the cavity **20** of the tower **14**. Because the cover **18** can simply remain with the reinforcement unit **10**, it creates no additional waste that must later be disposed.

The reinforcement unit **10** can be formed from a variety of compositions that can withstand a wide range of environmental conditions, such as high density polyethylene (HDPE), rubber or the like, using a suitable process such as injection molding. Other materials and other manufacturing processes can be used in the alternative. In some embodiments, the reinforcement unit **10** is formed from a composition comprising polypropylene and glass. In one embodiment, the reinforcement unit **10** is formed from a composition comprising between about 75% and 95% polypropylene and between about 5% and 25% glass.

The reinforcement unit **10** may be manufactured using a method in which varying thicknesses for the base **12** and tower **14** can be achieved using the same type of molding process. The thickness for a particular application is dependent on the end use of the reinforcement unit **10**. Suitable manufacturing processes including, but are not limited to, injection molding, blow molding, extrusion, and thermoforming. The thickness of the tower **14** should be sufficient to withstand the forces generated by the backfill material **34** placed around the tower **14** and compacted during construction of the segmental retaining wall **32** behind which the reinforcement unit **10** can be installed.

The reinforcement unit **10** can be used to form a footing for supporting a structure, such as the fence post **30**, when the fence post **30** is installed behind the segmental retaining wall **32** (FIGS. **12** and **13**).

The spacing between adjacent reinforcement units **10** is dependent upon the desired distance (spacing) between adjacent fence posts **30**. The cover **18** may have a plurality of notches **24** which may receive the tab (not shown) commonly located on the end of conventional tape measures. At least one of the notches **24** may act as a convenient means for holding the tab at the reinforcement unit **10**, as the position of the adjacent reinforcement unit **10** is determined based on measurements obtained from the tape measure.

The segmental retaining wall **32** can initially be constructed in a conventional manner. For example, a trench for

receiving a lowermost (base) row of blocks **36** can be excavated along the planned path of the wall **32** (the blocks **36** can be, for example, mortarless concrete blocks). The ground at the bottom of the trench can be stabilized and compacted using a vibrating mechanical plate. The base row of blocks **36** can be placed in the trench and leveled.

The voids in each block **36** can be filled with crushed stone or other suitable material. The area in back of the blocks **36** can be backfilled to the approximate height of the blocks **36** using crushed stone **34** or other suitable material. As used herein, the term "backfill material," refers to filling material, such as crushed stone or soil, used to fill the area behind the wall **32**. The area behind the crushed stone can be filled with on-site soil **38**. Filling material other than the crushed stone **34** and on-site soil **38** can be used as backfill, in the alternative.

Successive overlying rows of blocks **36** can be formed in a similar manner. A reinforcing tie back subsystem, such as sheets of geogrid **40**, can be attached to each row of blocks **36**. The sheets of geogrid **40** can extend outward from the blocks **36**, onto the adjacent layer of backfill material **34**, by a predetermined distance. Each sheet of geogrid **40** should be tensioned before being covered by the overlying layer of backfill material **34**.

The reinforcement unit **10** should be installed so that the top of the tower **14** is accessible from above ground after the wall **32** has been completed and back-filled (FIG. **13**). The weight of the backfill material **34** acting on the bottom portion of the tower **14** can help to stabilize the reinforcement unit **10** during installation.

The reinforcement unit **10** should be positioned so that the main portion of the tower **14** contacts the adjacent row of blocks **36** (FIG. **13**). Positioning the reinforcement unit **10** in this manner can help to minimize the spacing between the fence post **30** and the wall **32** when the fence post **30** is subsequently installed. Moreover, positioning the reinforcement unit **10** in this manner places all, or at least a portion of the tower **14** on the underlying crushed stone **34**.

The remaining rows of blocks **36** and layers of backfill material **34** can subsequently be completed, in substantially the same manner as the previous the rows and layers. Caps **42** can be installed on top of the uppermost row of blocks **36**, if desired.

The tower **14** forms a cavity **20** in the backfill material **34**. The cavity **20** can accommodate the bottom portion of the fence post **30**. The reinforcement unit **10** can remain in place, with the cover **18** installed, until the fence post **30** is about to be installed. The cover **18** can prevent substantial amounts of soil or other debris from falling into the cavity **20** formed by the tower **14** before the fence post **30** is installed. Moreover, the cover **18** can reduce or eliminate the potential for injuries caused by tripping over or stepping into an open hole in the ground. Hence, the cover **18** can be particularly beneficial in applications where the fence post **30** will not be installed immediately upon completion of the wall **32**.

As discussed above, in some embodiments, the upper end of the tower **14** comprises a frangible section. This allows a user to easily fracture (i.e., separate) the cover **18** from the upper end of the tower **14**. Once separated, the cover **18** can fall into the cavity **24** of the tower **14**, thus eliminating additional waste (FIG. **11**). Alternatively, the separated cover **18** can be removed and discarded.

After the cover **18** has been punched away and has fallen into the cavity **20**, the lower portion of the fence post **30** can be placed in the cavity **20** formed by the tower **14**. A suitable anchoring material, such as 3,000 psi concrete, can be

poured into the tower **14** after the lower portion of the fence post **30** has been placed therein (FIG. **13**). The use of 3,000 psi concrete as the anchoring material is specified for exemplary purposes only. Other types of anchoring materials can be used in the alternative.

The anchoring material fills the cavity **20** formed by the tower **14**, and immerses the lower portion of the fence post **30**. The anchoring material (e.g., the concrete upon hardening) and the portion of the base **12** immersed in the concrete form a reinforced concrete footing for the fence post **30**. The base **12** can interact with the surrounding backfill material **34**, e.g., soil, crushed stone, etc., to generate forces that resist bending moments and linear forces on the fence post **30**.

Many design codes and site plans require a fence post **30** installed directly adjacent a segmental retaining wall **32** to withstand an applied load of approximately twenty pounds per linear foot of fence **44**. The use of the reinforcement unit **10**, it is believed, provides the fence post **30** with sufficiently reinforcement to meet this standard.

The use of the reinforcement unit **10**, by permitting the fence post **30** (and the associated fence **44**) to be installed directly adjacent the wall **32**, can obviate the need for a setback between the wall **32** and the fence **44**. Hence, the underutilization of real estate, and the potential safety hazard resulting from the use of such setbacks can be eliminated.

Eliminating the need for a setback also can eliminate the potential for mistakenly installing the fence **44** too close to the wall **32** in violation of a design code or site plan. Hence, the potential need to remove and reinstall the fence **44** due to such mistakes can be reduced or eliminated through the use of the reinforcement unit **10**. Moreover, the footing support, it is believed, can be constructed without using substantially more concrete than a footing constructed in a conventional manner.

The foregoing is illustrative of the present invention and is not to be construed as limiting thereof. Although exemplary embodiments of this invention have been described, those skilled in the art will readily appreciate that many modifications are possible in the exemplary embodiments without materially departing from the novel teachings and advantages of this invention. Accordingly, all such modifications are intended to be included within the scope of this

invention as defined in the claims. The invention is defined by the following claims, with equivalents of the claims to be included therein.

That which is claimed is:

- 5 **1.** A reinforcement unit for creating a footing for supporting a structure, comprising:
  - a base extending in a first direction; and
  - a tower extending in a second direction from a first end of the base that is generally perpendicular to said base, a top portion of the tower having a width or a diameter smaller than a width or diameter of a bottom portion of the tower, the tower defining a cavity for receiving a portion of the structure and an anchoring material, wherein the portion of the structure is inserted into the cavity by way of a top of the cavity, and the width or diameter of the top portion of the tower is substantially greater than the outer dimensions of the portion of the structure so that the anchoring material can be introduced into the cavity by way of the top of the cavity while the portion of the structure is positioned within the cavity,
  - wherein a second end of the base comprises a pocket substantially similar in width or diameter to the top portion of the tower such that a second identical reinforcement unit can be inverted and stacked on top of the reinforcement unit.
- 10 **2.** The reinforcement unit of claim **1**, wherein the base and the tower are formed from a composition comprising about 90% polypropylene and about 10% glass.
- 15 **3.** The reinforcement unit of claim **1**, wherein the tower is frusto-conical.
- 20 **4.** The reinforcement unit of claim **1**, wherein the base comprises a grid pattern.
- 25 **5.** The reinforcement unit of claim **1**, wherein the reinforcement unit comprises a plurality of reinforcing members adjacent to the tower and the base.
- 30 **6.** The reinforcement unit of claim **1**, wherein the base and the tower form a monolithic component.
- 35 **7.** The reinforcement unit of claim **1**, wherein the top portion of the tower comprises a frangible section.
- 40 **8.** The reinforcement unit of claim **1**, wherein two or more of the reinforcement units are stackable on top of one another.

\* \* \* \* \*