



US 20140020767A1

(19) **United States**
(12) **Patent Application Publication**
Nelson et al.

(10) **Pub. No.: US 2014/0020767 A1**
(43) **Pub. Date: Jan. 23, 2014**

(54) **MAGNETIC COUPLING FOR SPRAYHEADS**

(71) Applicant: **Masco Corporation of Indiana,**
Indianapolis, IN (US)
(72) Inventors: **Alfred Charles Nelson,** Westfield, IN
(US); **Christopher Michael McGuire,**
Fishers, IN (US)
(73) Assignee: **Masco Corporation of Indiana,**
Indianapolis, IN (US)

division of application No. 12/059,403, filed on Mar.
31, 2008, now Pat. No. 7,753,079, which is a continu-
ation-in-part of application No. 11/393,450, filed on
Mar. 30, 2006, now Pat. No. 7,909,061.
(60) Provisional application No. 60/691,389, filed on Jun.
17, 2005.

(21) Appl. No.: **13/951,310**
(22) Filed: **Jul. 25, 2013**

Publication Classification
(51) **Int. Cl.**
E03C 1/04 (2006.01)
(52) **U.S. Cl.**
CPC **E03C 1/04** (2013.01)
USPC **137/15.01; 137/315.01**

Related U.S. Application Data

(60) Continuation of application No. 12/650,330, filed on
Dec. 30, 2009, now Pat. No. 8,496,028, which is a

(57) **ABSTRACT**
A faucet including a faucet head, a body and a magnetic
coupling releasably coupling the faucet head to the faucet
body.

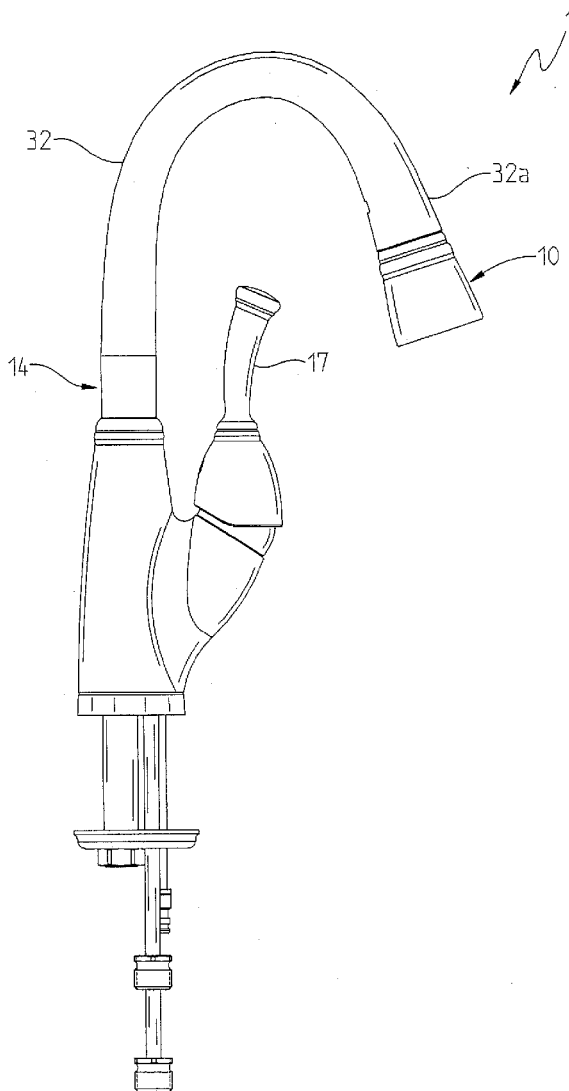

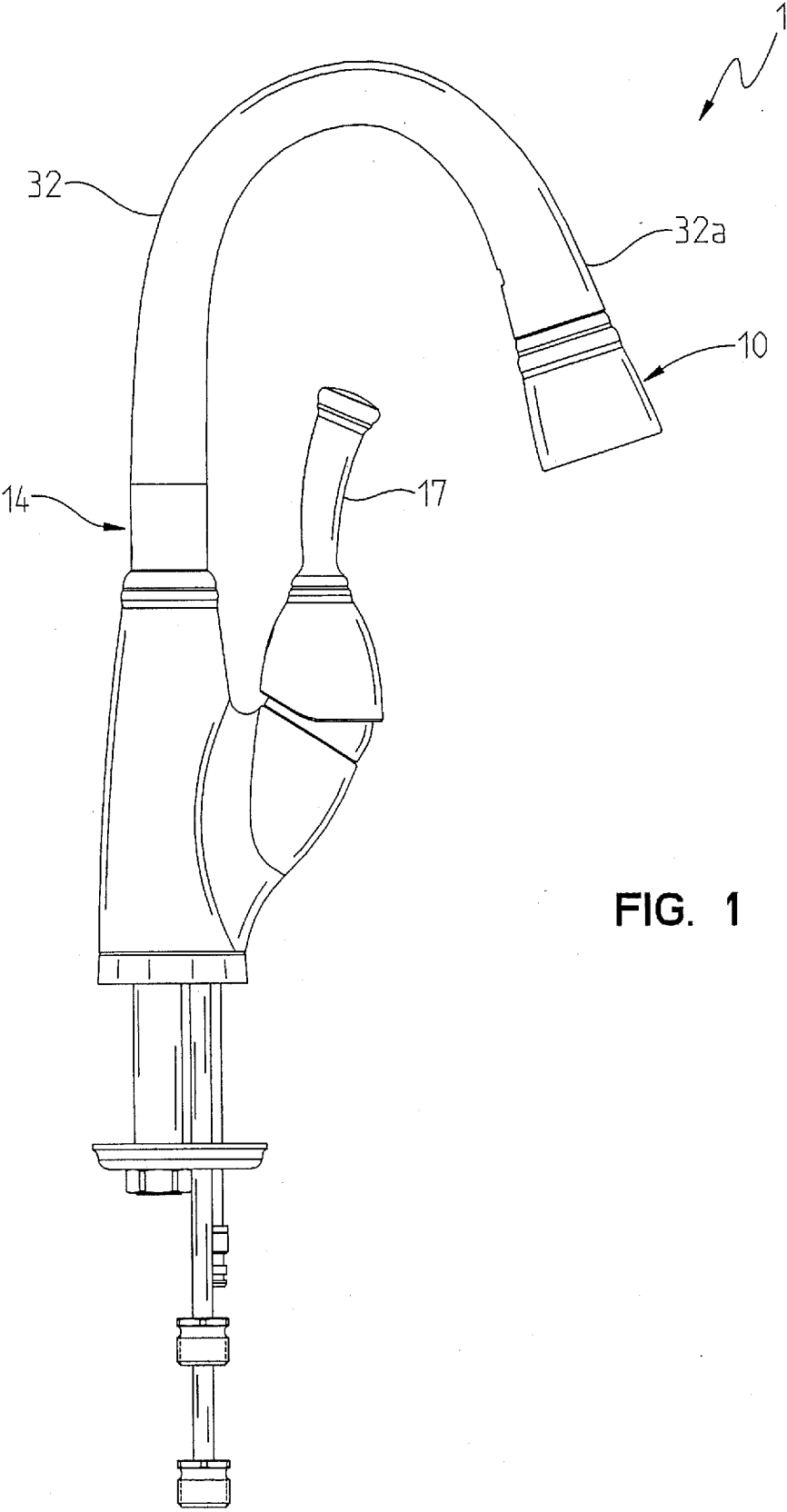

FIG. 1

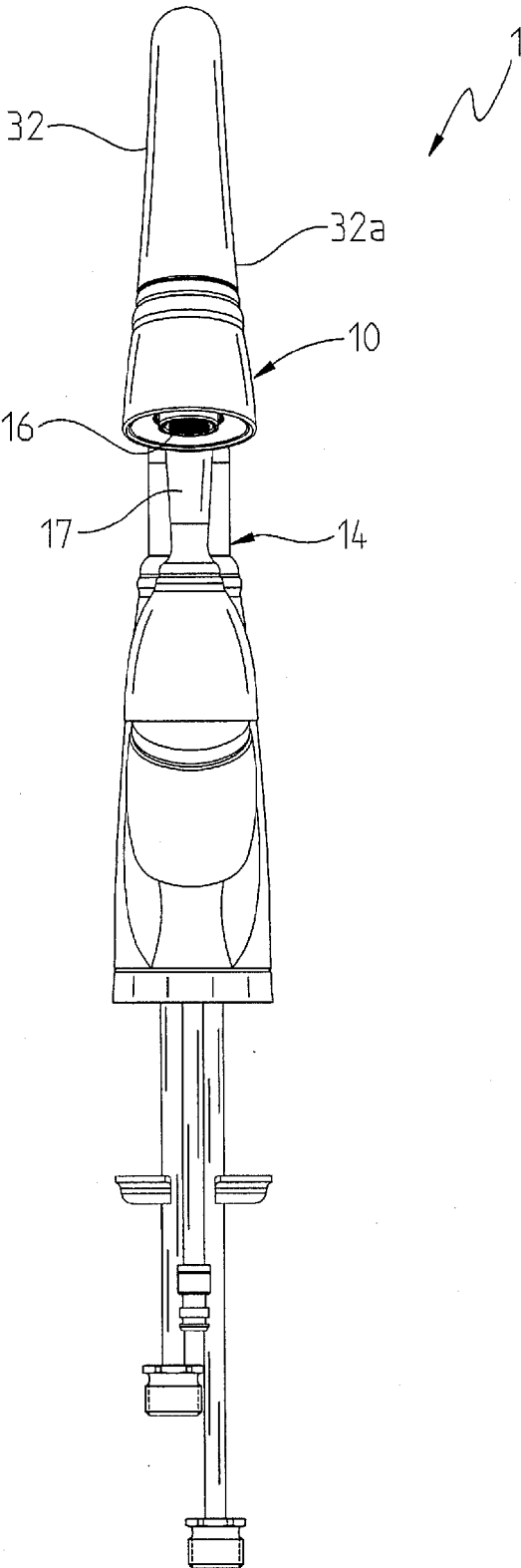

FIG. 2

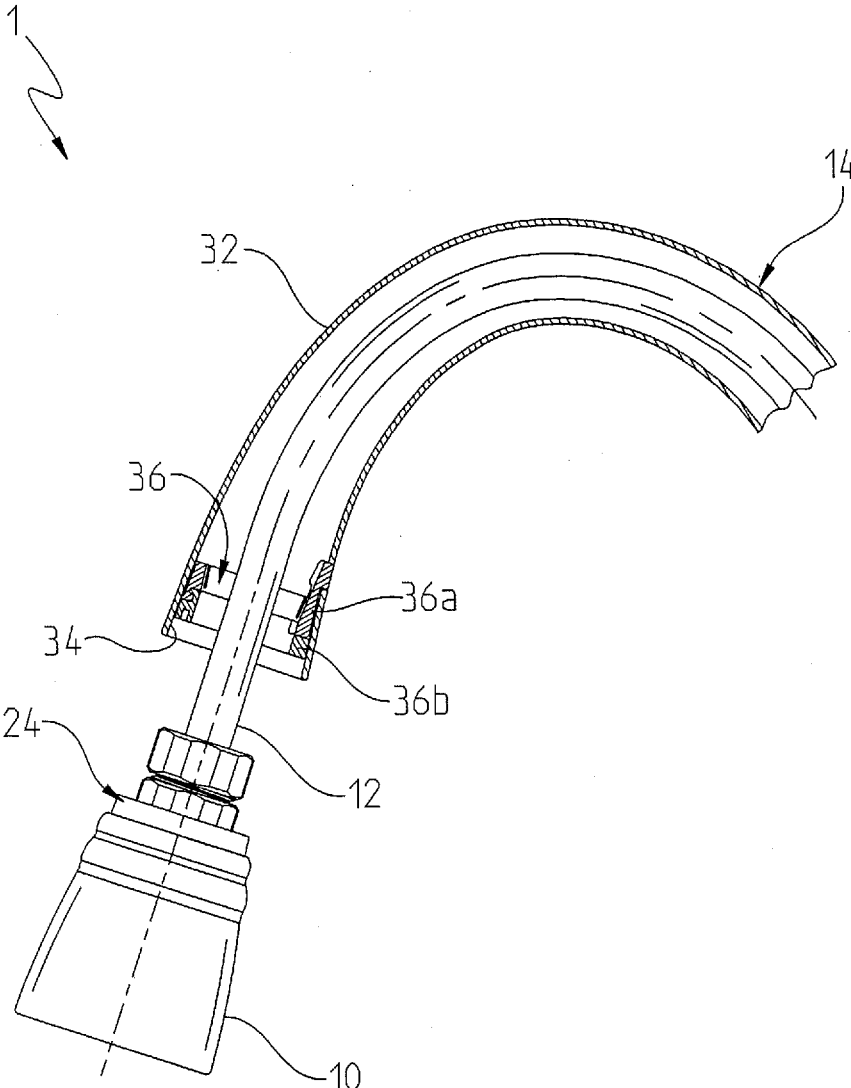

FIG. 3

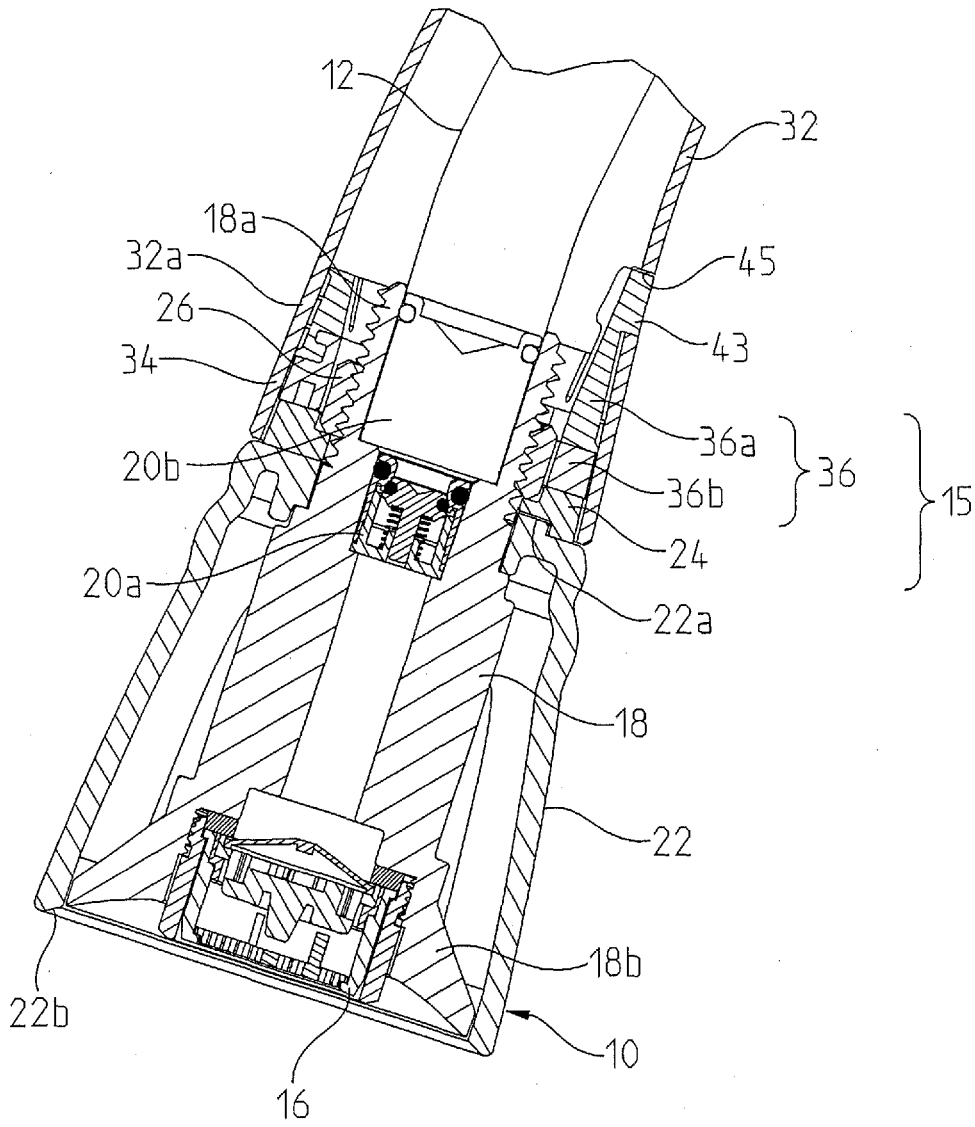

FIG. 4

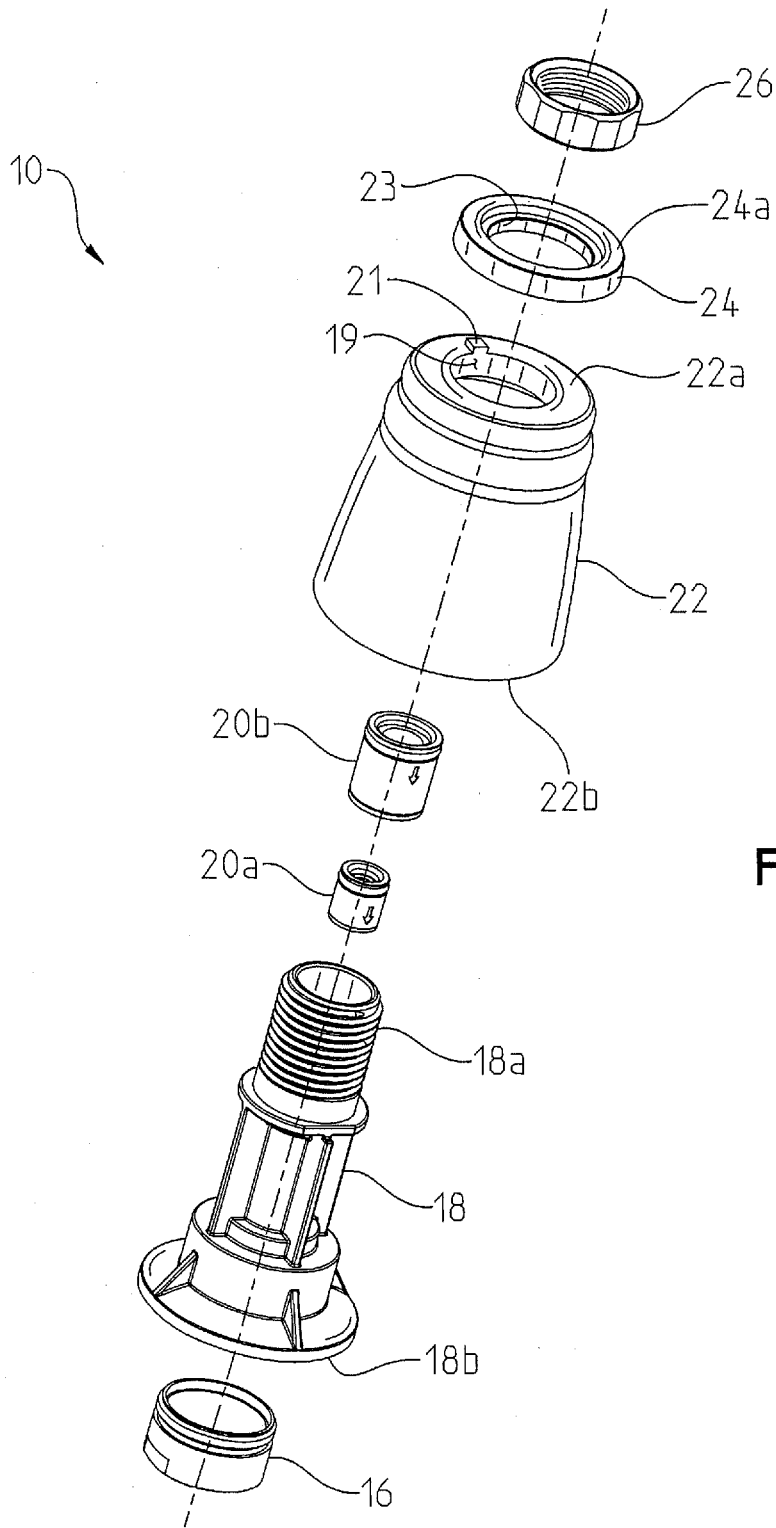

FIG. 5

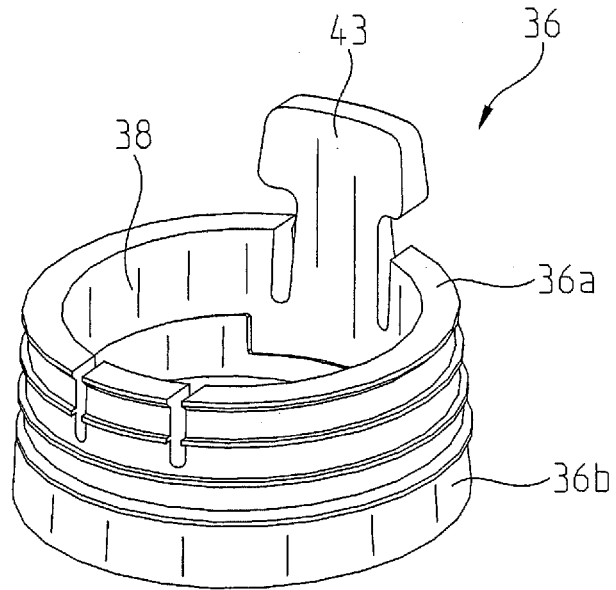

FIG. 6A

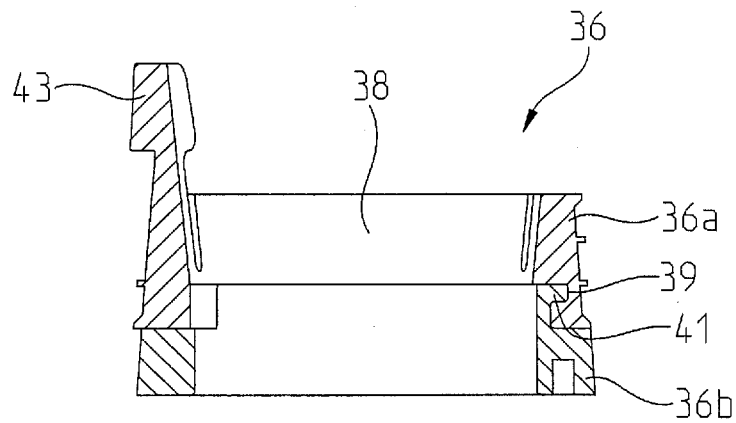

FIG. 6E

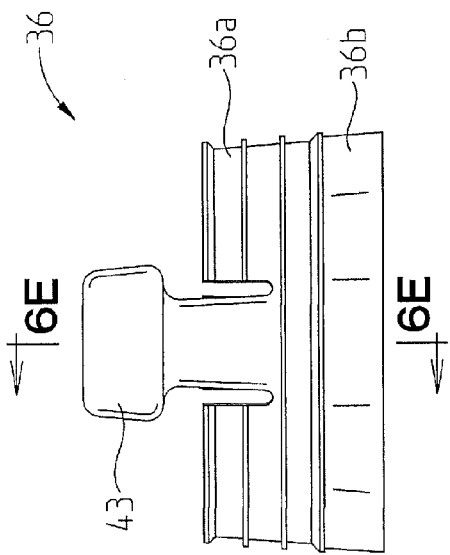

FIG. 6B

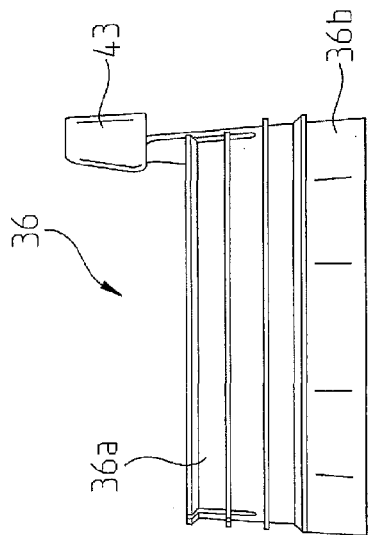

FIG. 6C

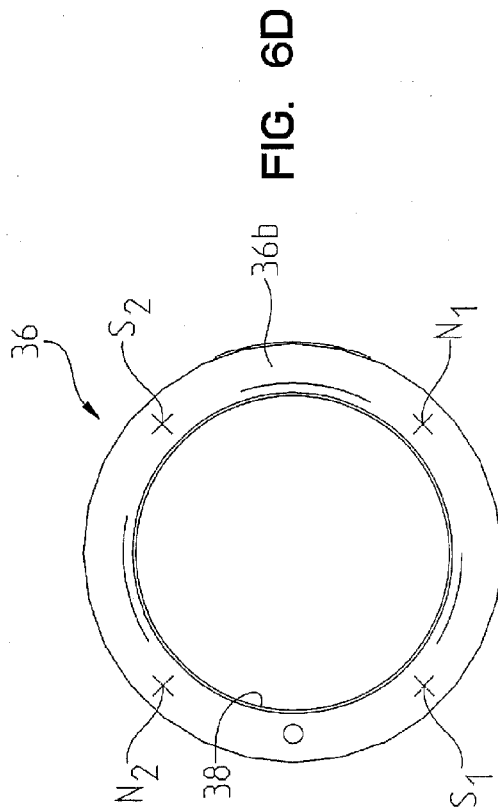

FIG. 6D

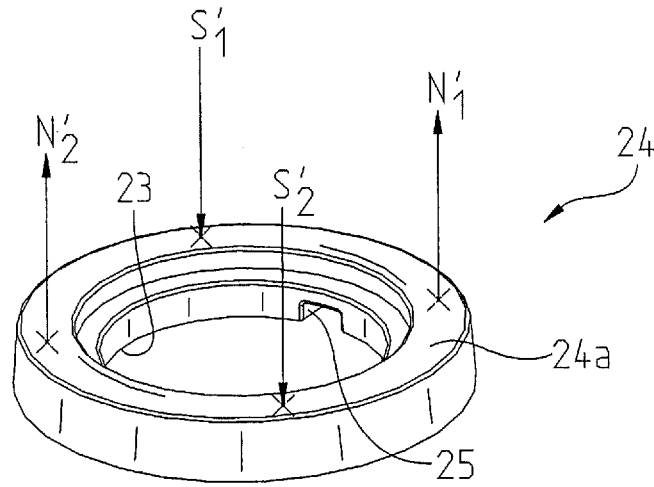

FIG. 7A

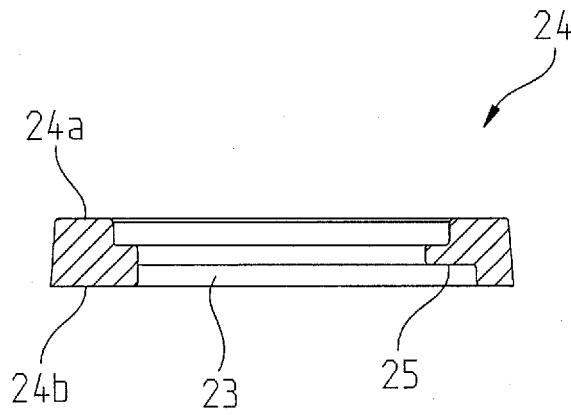

FIG. 7E

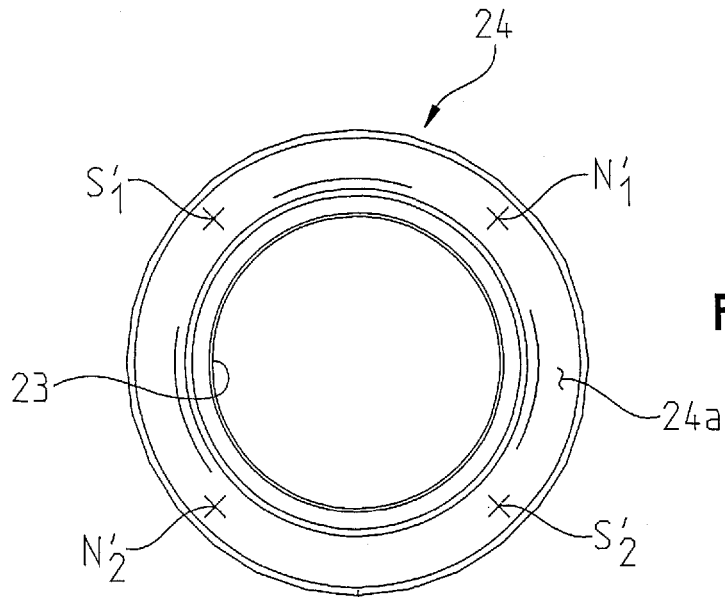

FIG. 7B

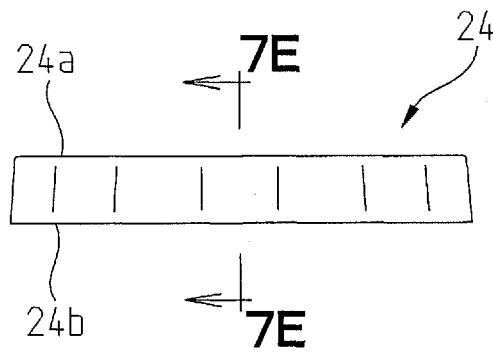

FIG. 7C

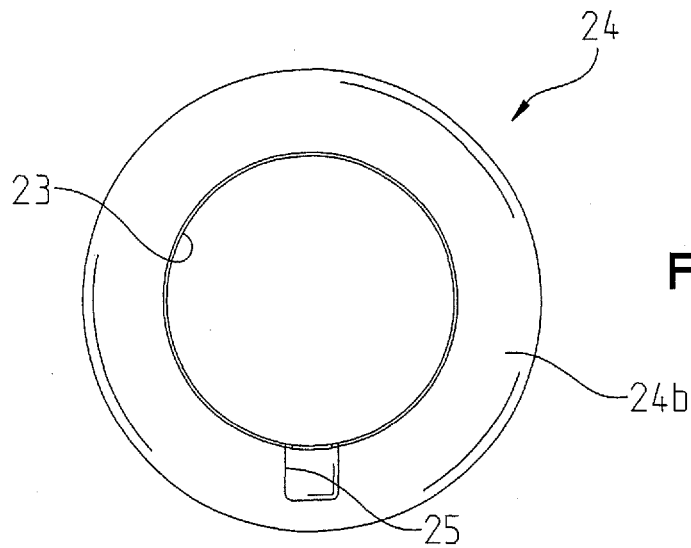

FIG. 7D

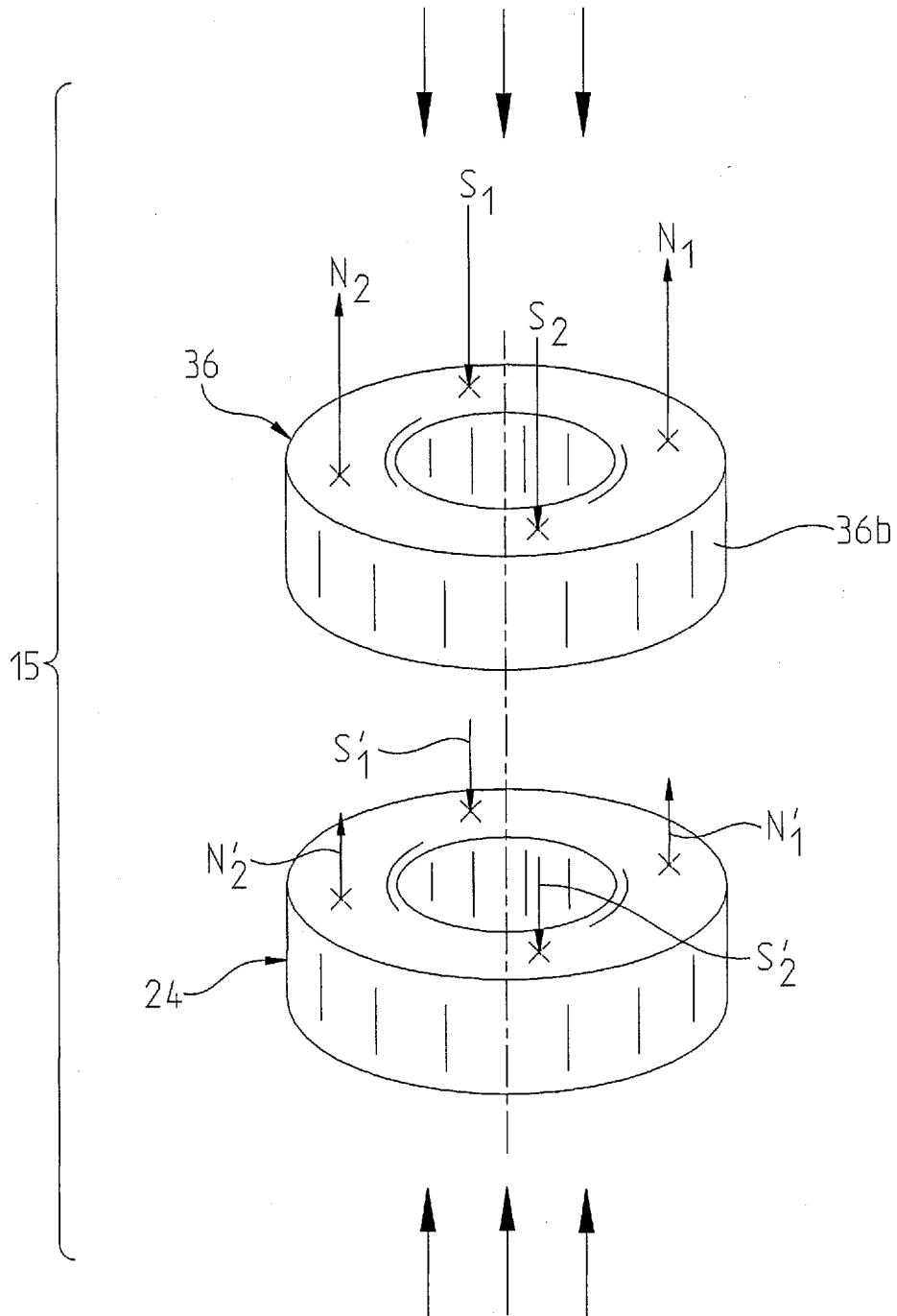

FIG. 8A

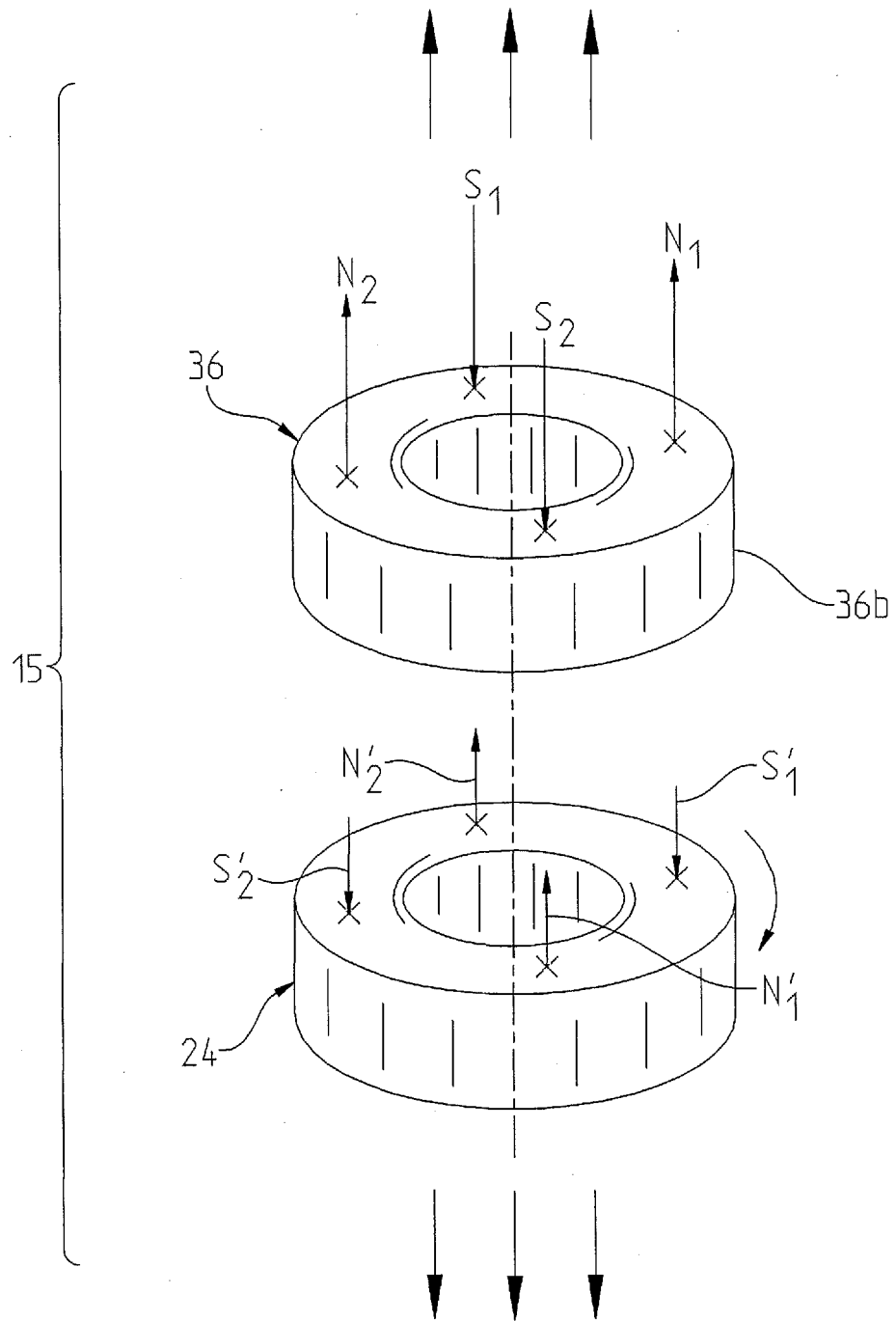

FIG. 8B

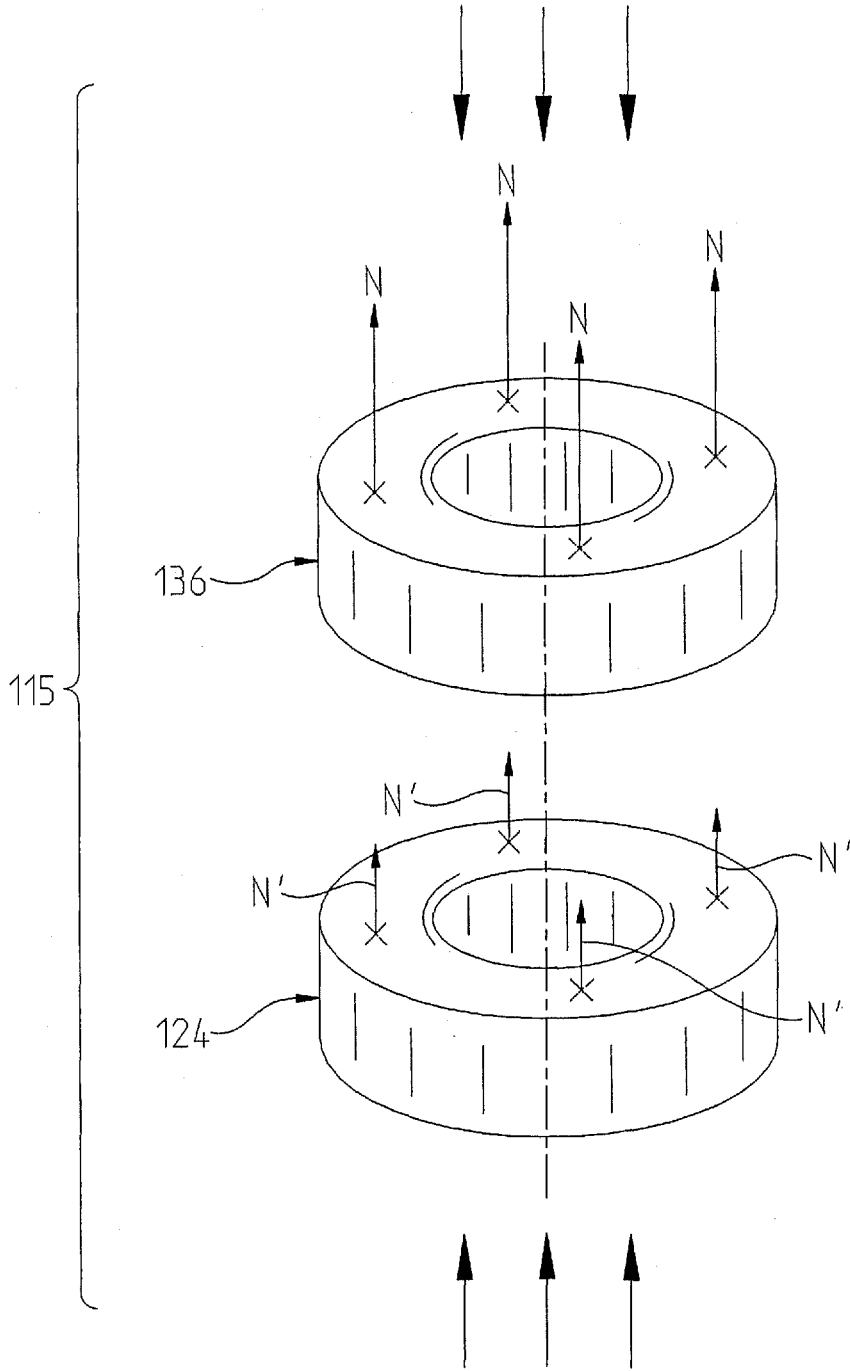

FIG. 9

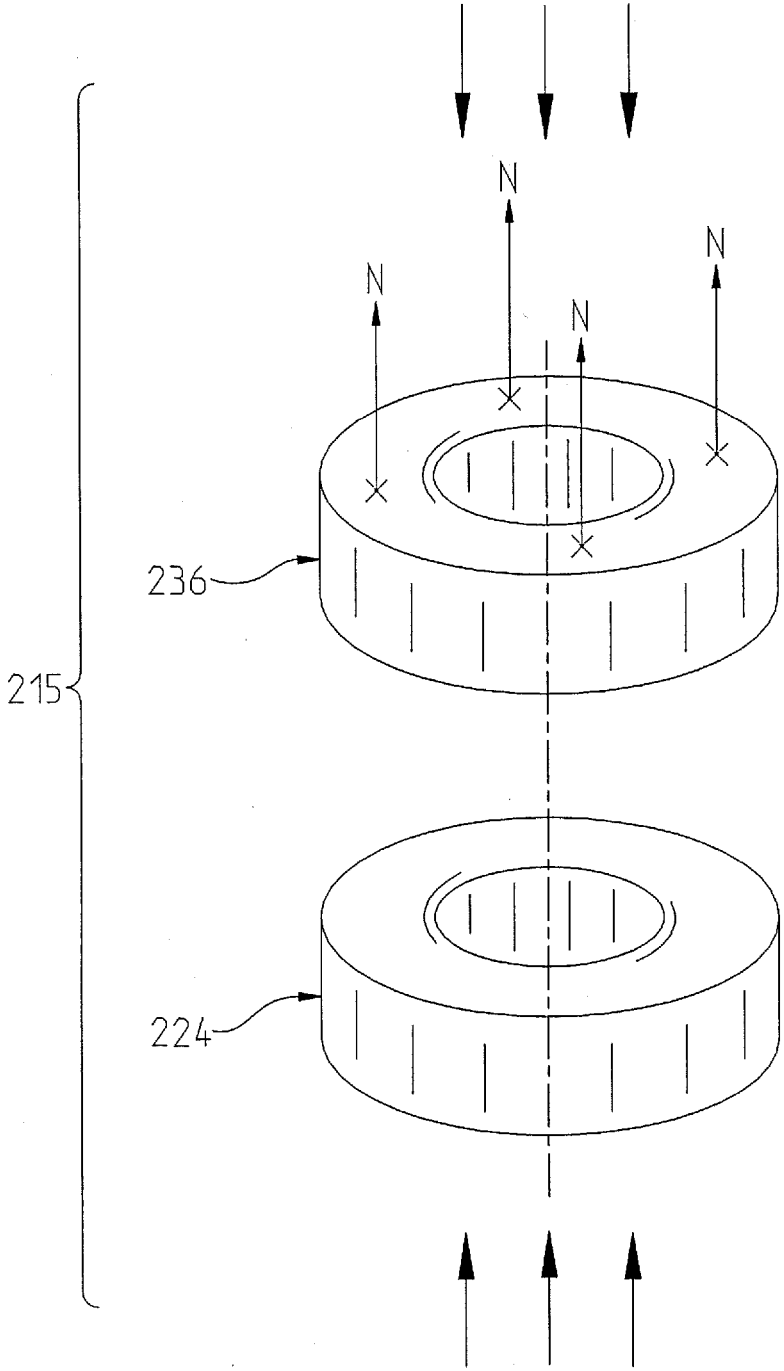

FIG. 10

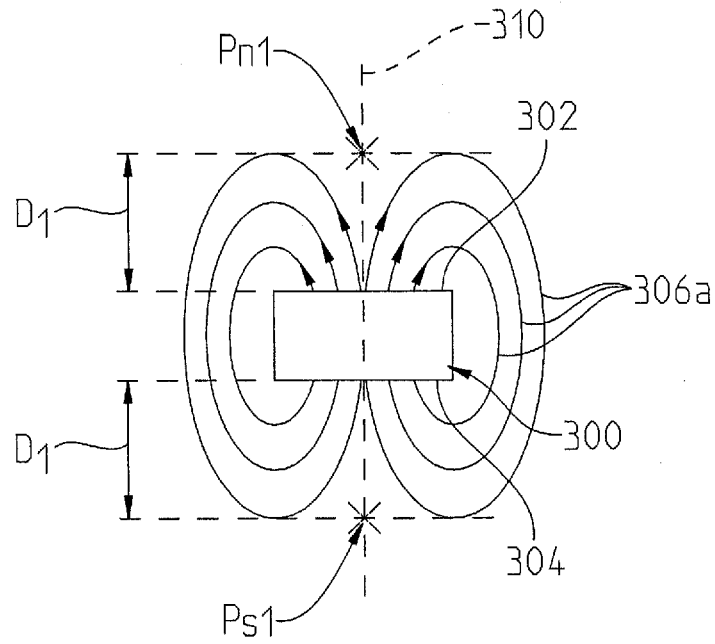

FIG. 11A

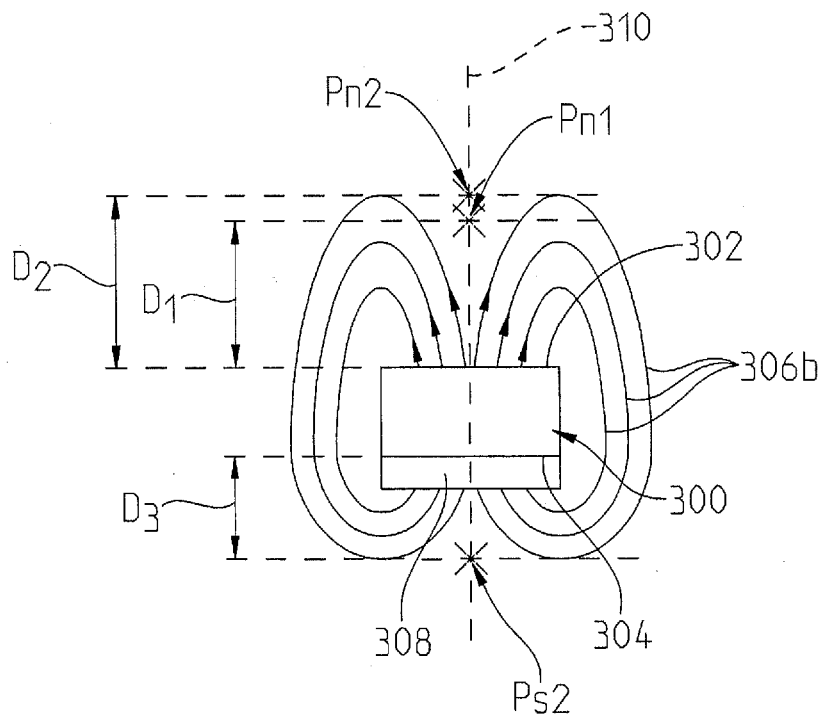

FIG. 11B

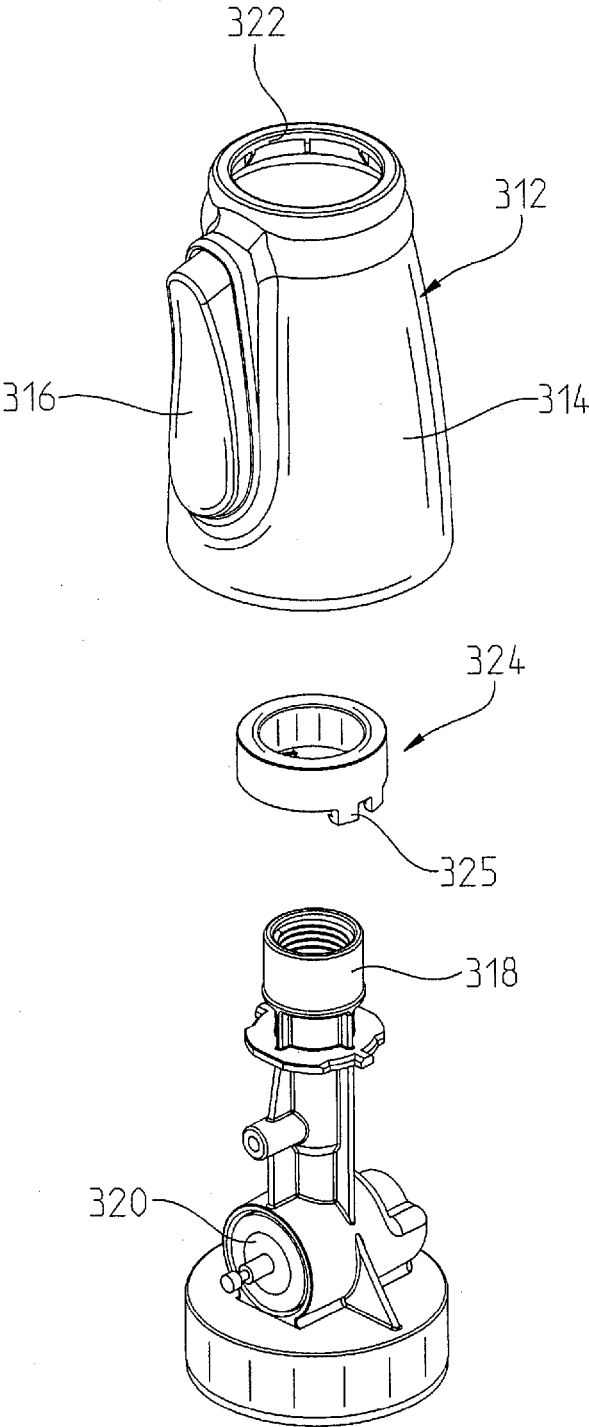

FIG. 12A

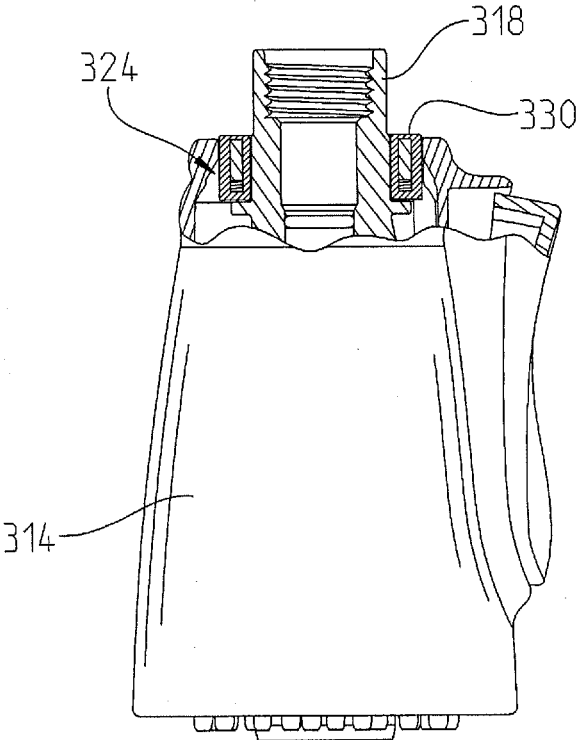

FIG. 12B

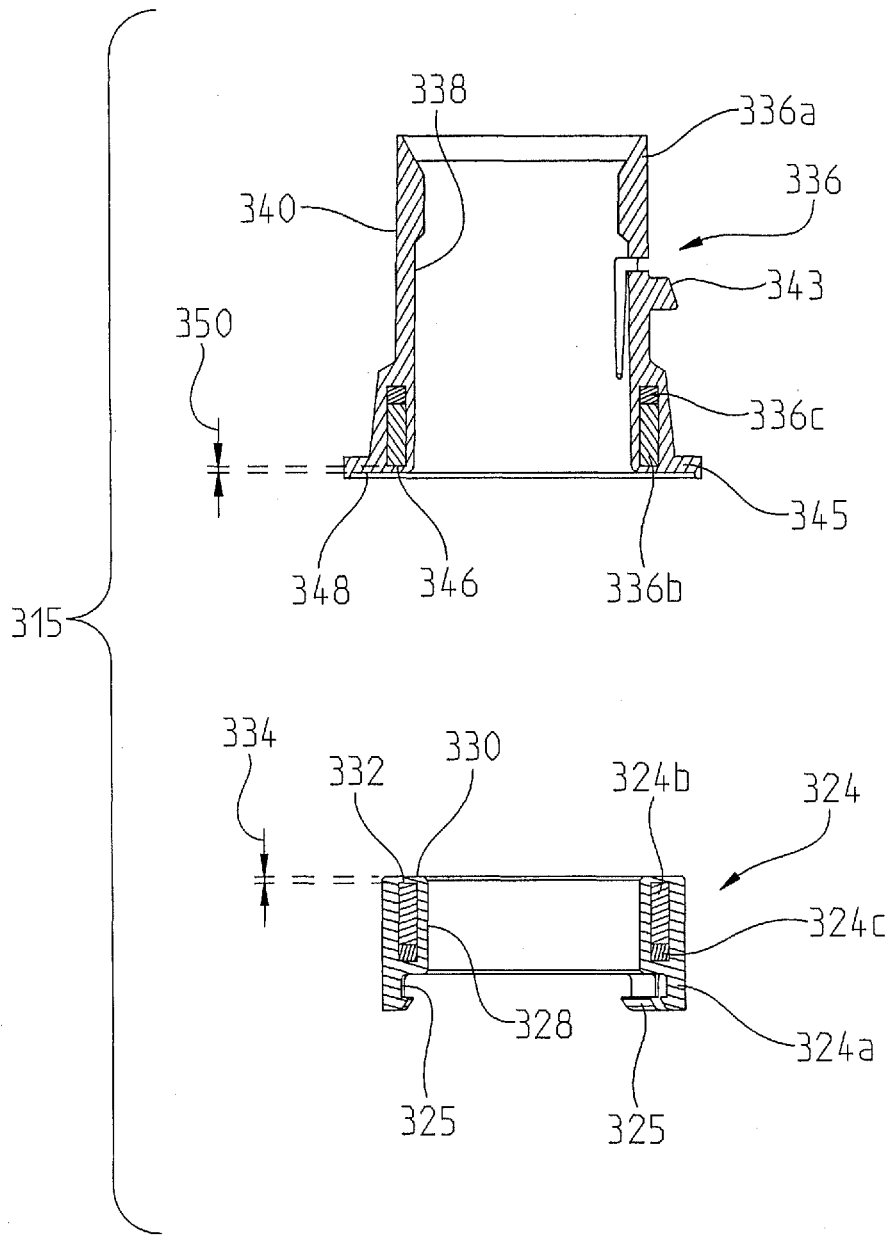

FIG. 13A

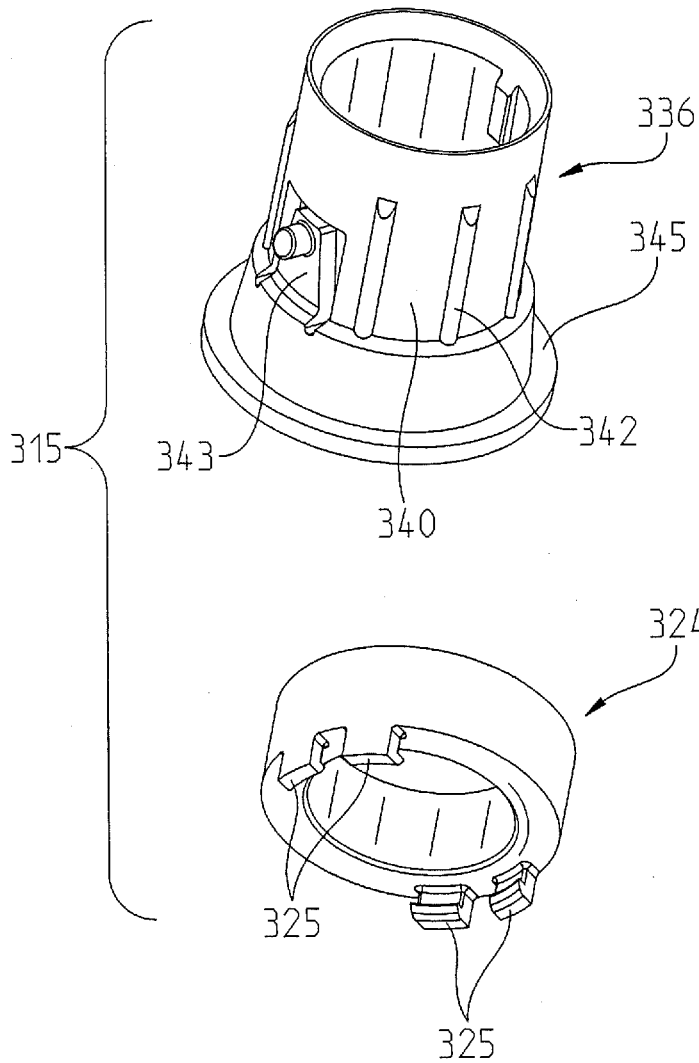

FIG. 13B

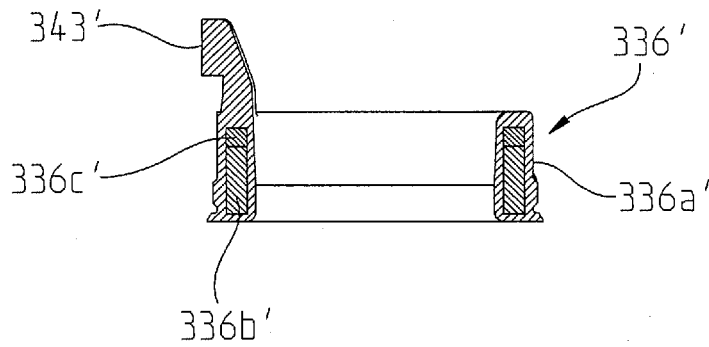

FIG. 13C

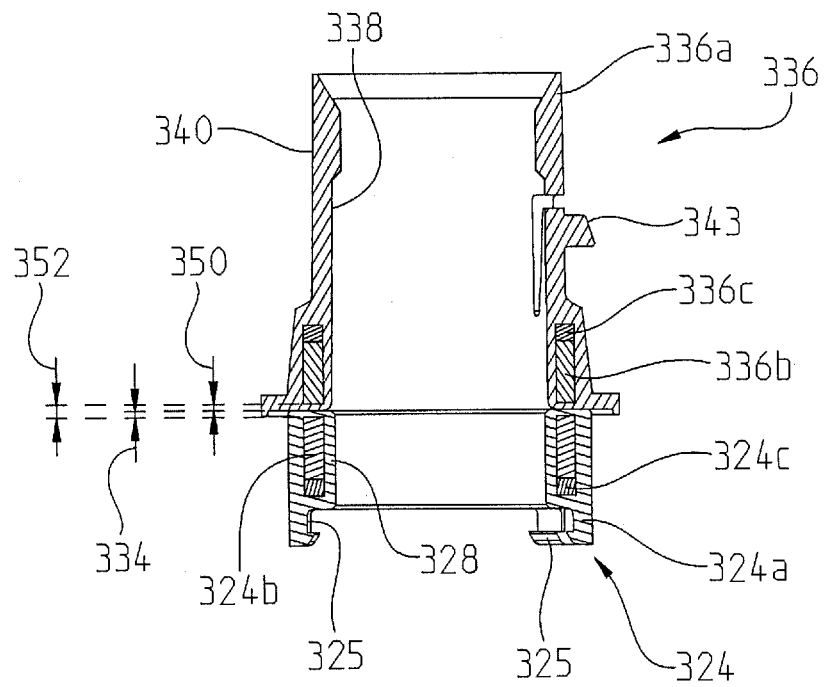

FIG. 13D

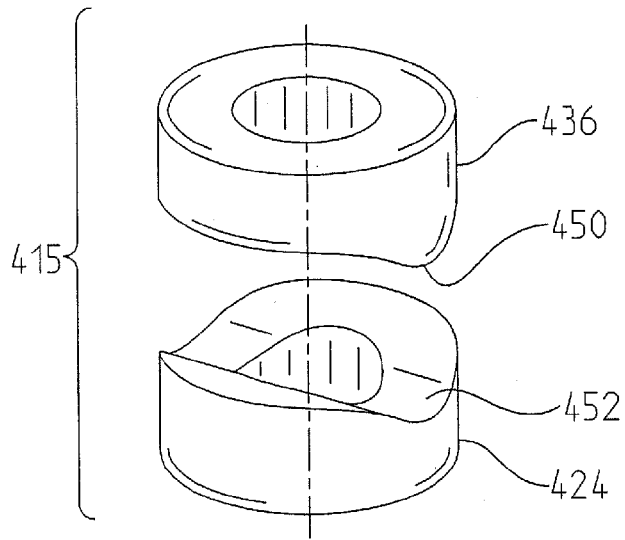

FIG. 14

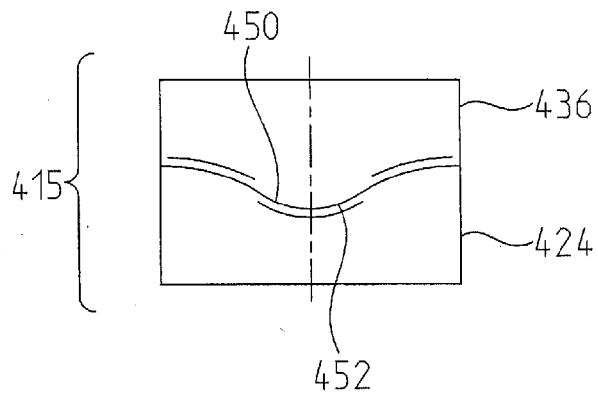

FIG. 14A

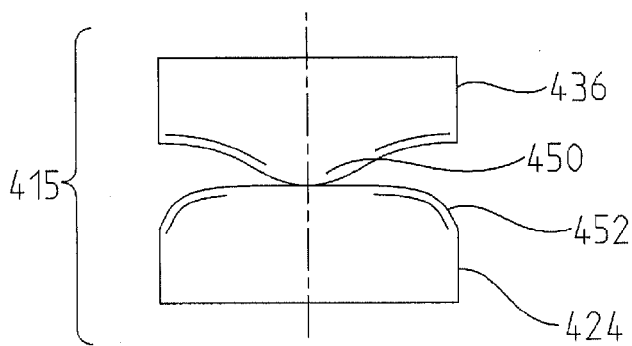

FIG. 14B

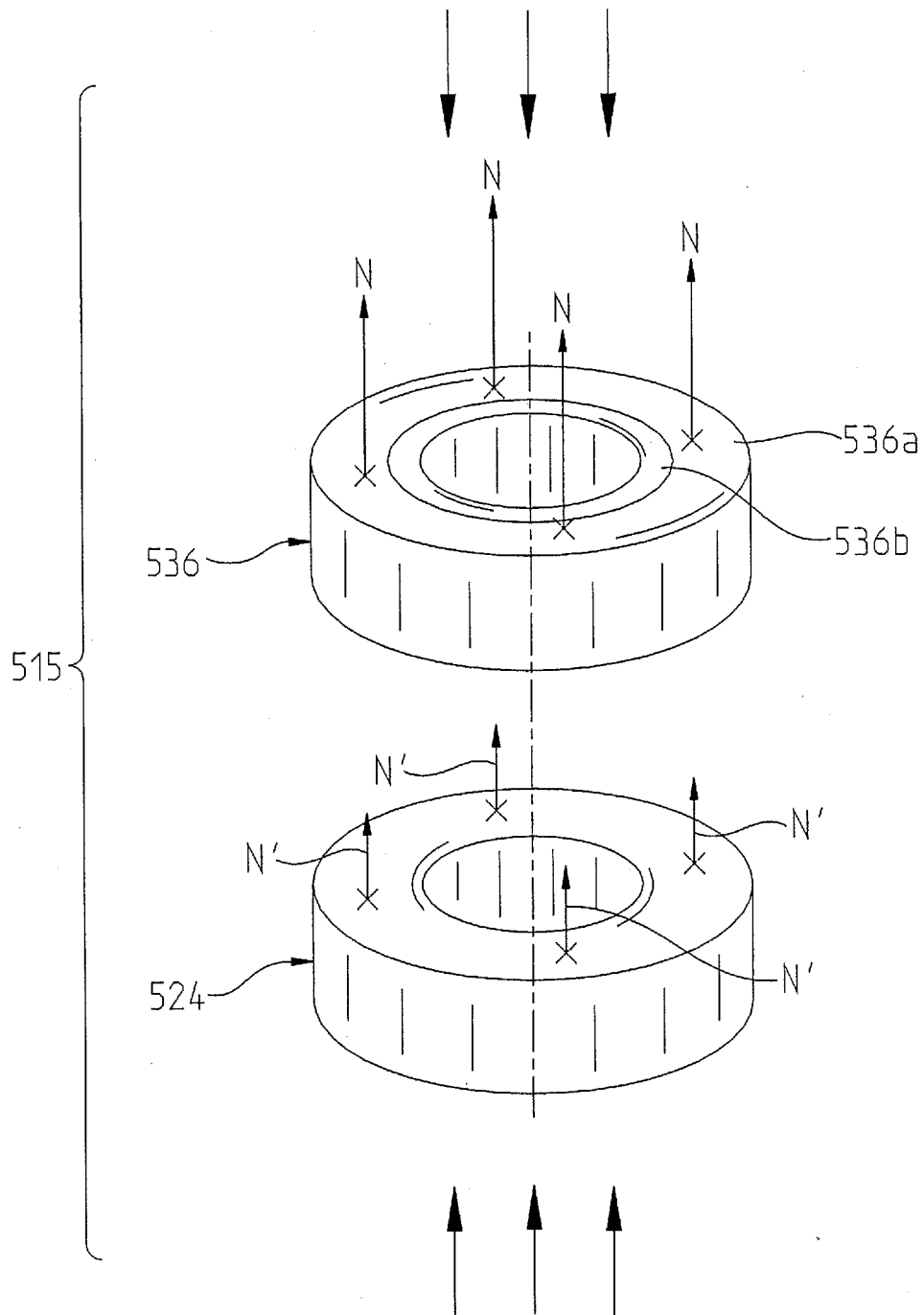

FIG. 15A

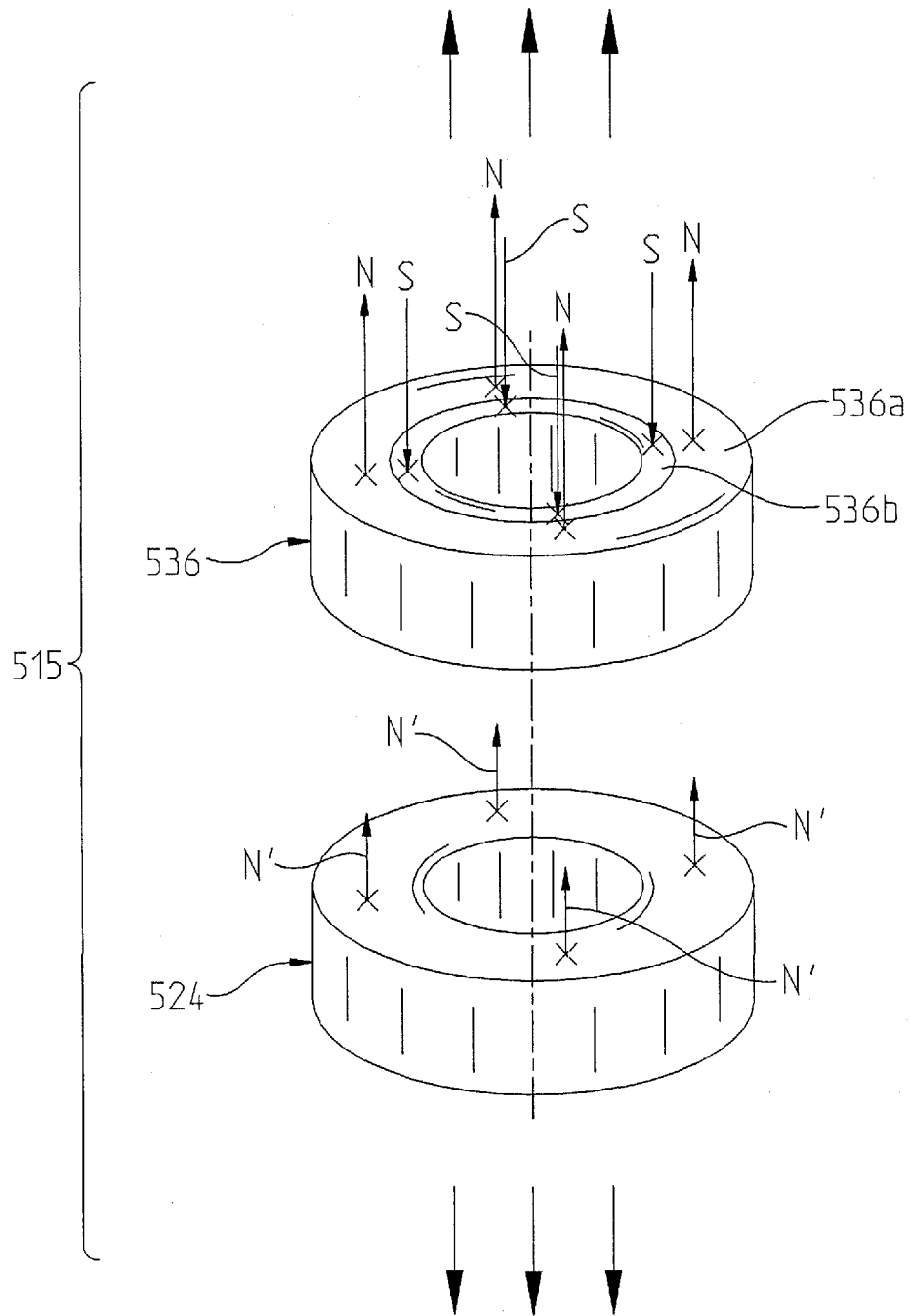

FIG. 15B

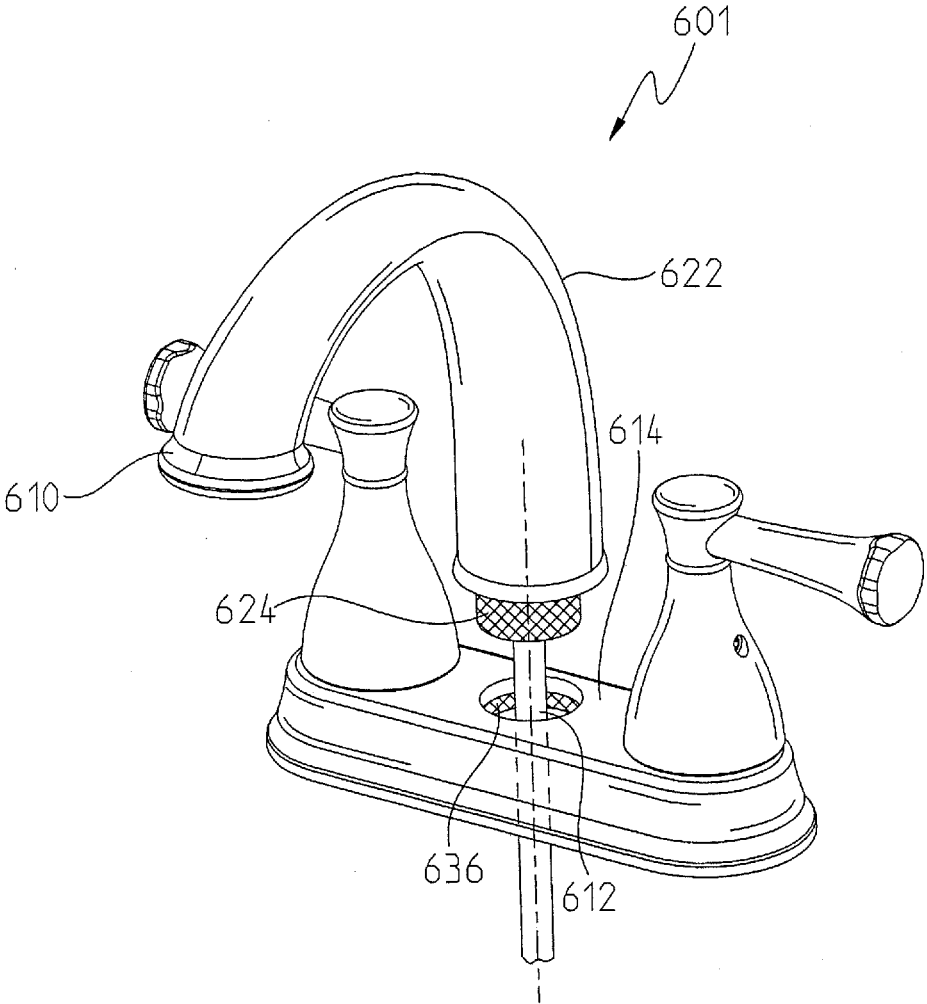

FIG. 16

MAGNETIC COUPLING FOR SPRAYHEADS

CROSS-REFERENCE TO RELATED APPLICATION

[0001] This application is a continuation of co-pending U.S. patent application Ser. No. 12/650,330, filed Dec. 30, 2009, which is a divisional of U.S. patent application Ser. No. 12/059,403, filed Mar. 31, 2008, now U.S. Pat. No. 7,753,079, which is a continuation-in-part of U.S. patent application Ser. No. 11/393,450, filed Mar. 30, 2006, now U.S. Pat. No. 7,909,061, which claims the benefit of U.S. Provisional Application No. 60/691,389, filed Jun. 17, 2005, the disclosures of which are expressly incorporated by reference herein.

BACKGROUND AND SUMMARY OF THE INVENTION

[0002] The present invention relates to faucets having pull-out sprayheads and, more particularly, to improvements in the manner by which the sprayhead is coupled and/or uncoupled from the faucet body.

[0003] Faucets having sprayheads that pull out from the faucet body enable users to manipulate the sprayhead independent of the faucet body and to aim the water spray directly at a target instead of requiring the user to place the target under the sprayhead. Such prior art faucets typically utilize locking bayonet connectors, or connectors comprising collars and snap fingers to produce a retaining force to couple the sprayhead to the faucet body.

[0004] One embodiment of the present invention generally provides a liquid dispensing assembly comprising a supply hose adapted to supply a liquid, a dispensing member fluidly coupled to the supply hose and adapted to dispense the liquid, a support member adapted to support the dispensing member, and a magnetic coupling to removably couple the dispensing member to the support member. The magnetic coupling includes a magnetic member supported by one of the support member and the dispensing member. The magnetic member is dipolar and has a magnetic field of between 400 and 2,000 gauss tested at 0.090 inches. The attracted member is magnetically attracted to the magnetic member and supported by the other of the dispensing member and the support member. The magnetic coupling requires between 2.0 and 12.0 pounds of force to pull the dispensing member from the support member.

[0005] Another embodiment of the present invention generally provides a method of dispensing liquid. The method comprises the steps of fluidly coupling a dispensing member to a source of liquid through a supply line, supporting the dispensing member with a support member, magnetically holding the dispensing member in a coupled position with the support member, applying force to separate the dispensing member from the support member, and placing the dispensing member proximally to the support member to removably and magnetically couple the dispensing member to the support member. The dispensing member comprises one of a magnetic member and an attracted member, the magnetic member being dipolar and having a magnetic field of between 400 and 2,000 gauss tested at 0.090 inches. The supply line is adapted to extend from the support member when the dispensing member is separated from the support member, the support member comprising the other of the magnetic member and the attracted member.

[0006] The above mentioned and other features of this invention, and the manner of attaining them, will become more apparent and the invention itself will be better understood by reference to the following description of embodiments of the invention taken in conjunction with the accompanying drawings.

BRIEF DESCRIPTION OF THE DRAWINGS

[0007] The detailed description of the drawings particularly refers to the accompanying figures in which:

[0008] FIG. 1 is a side view of a faucet in accordance with one embodiment of the present invention;

[0009] FIG. 2 is a front view of the faucet of FIG. 1;

[0010] FIG. 3 is a partial cross-sectional view of a portion of the faucet of FIG. 1;

[0011] FIG. 4 is a detailed cross-sectional view of a portion of the faucet of FIG. 1;

[0012] FIG. 5 is an exploded perspective view of the faucet of FIG. 4;

[0013] FIG. 6A is a perspective view of the body connector of the faucet of FIG. 4;

[0014] FIG. 6B is a side view of the body connector of FIG. 6A;

[0015] FIG. 6C is another side view of the body connector of FIG. 6A;

[0016] FIG. 6D is a bottom view of the body connector of FIG. 6A;

[0017] FIG. 6E is a cross-sectional view of the body connector of FIG. 6C taken along line 6E-6E;

[0018] FIG. 7A is a perspective view of the head connector of the faucet of FIG. 4;

[0019] FIG. 7B is a top view of the head connector of FIG. 7A;

[0020] FIG. 7C is a side view of the head connector of FIG. 7A;

[0021] FIG. 7D is a bottom view of the head connector of FIG. 7A;

[0022] FIG. 7E is a cross-sectional view of the head connector of FIG. 7C taken along line 7E-7E;

[0023] FIG. 8A is diagrammatic view of the magnetic coupling of the faucet of FIG. 4 in the attracting mode;

[0024] FIG. 8B is a diagrammatic view of the magnetic coupling of the faucet of FIG. 4 in the repelling mode;

[0025] FIG. 9 is a diagrammatic view of an alternative magnetic coupling for use in the faucet of FIG. 4;

[0026] FIG. 10 is a diagrammatic view of another alternative magnetic coupling for use in the faucet of FIG. 4;

[0027] FIG. 11A is a conceptual diagram of the flux lines of a magnetic field of a rectangular magnet.

[0028] FIG. 11B is a conceptual diagram of the flux lines of a magnetic field of a rectangular magnet coupled to a backing element.

[0029] FIG. 12A is an exploded perspective view of a faucet head including a magnetic connector having a backing element.

[0030] FIG. 12B is a side view of the faucet of FIG. 12A showing a partial detailed cross-section of the magnetic connector positioned in the faucet head.

[0031] FIG. 13A is a cross-sectional side view of an alternative magnetic coupling showing magnetic connectors including connecting elements and backing elements.

[0032] FIG. 13B is a perspective view of the alternative magnetic coupling of FIG. 13A.

[0033] FIG. 13C is a cross-sectional side view of an alternative magnetic connector.

[0034] FIG. 13D is a cross-sectional side view of the magnetic coupling of FIG. 13A.

[0035] FIGS. 14, 14A and 14B are diagrammatic views of yet another alternative magnetic coupling for use in the faucet of FIG. 4 illustrating various orientations of the head connector and body connector;

[0036] FIG. 15A is a diagrammatic view of yet another magnetic coupling for use in the faucet of FIG. 4, wherein the magnetic coupling is in the attracting mode;

[0037] FIG. 15B is a diagrammatic view of the magnetic coupling of FIG. 15A, wherein the magnetic coupling is in the repelling mode; and

[0038] FIG. 16 is a perspective view of a faucet in accordance with another illustrative embodiment of the present invention.

[0039] Corresponding reference characters indicate corresponding parts throughout the several views. Although the drawings represent embodiments of the present invention, the drawings are not necessarily to scale and certain features may be exaggerated in order to better illustrate and explain the present invention. Although the exemplification set out herein illustrates embodiments of the invention, in several forms, the embodiments disclosed below are not intended to be exhaustive or to be construed as limiting the scope of the invention to the precise forms disclosed.

DETAILED DESCRIPTION OF THE DRAWINGS

[0040] The embodiments hereinafter disclosed are not intended to be exhaustive or limit the invention to the precise forms disclosed in the following description. Rather the embodiments are chosen and described so that others skilled in the art may utilize its teachings.

[0041] Referring first to FIGS. 1 and 2, faucet 1 according to one embodiment of the present invention is illustrated. Faucet 1 generally includes sprayhead 10 and faucet body 14. Faucet 1 is of the type wherein sprayhead 10 may be pulled out and manipulated independent of body 14. More particularly, faucet body 14 includes neck or delivery spout 32 having dispensing end 32a to which sprayhead 10 is releasably coupled, as is described in further detail below.

[0042] Referring now to FIGS. 3-5, faucet 1 also includes flexible water supply line or spout tube 12, which extends through neck 32 and is fluidly coupled at a first end to a water supply source, illustratively through a valve (not shown) operably coupled to a handle 17 (FIG. 1). A second end of the water supply line 12 is fluidly coupled to sprayhead 10. The faucet 1 may include additional features detailed in U.S. patent application Ser. No. 11/325,128, filed Jan. 4, 2006, the disclosure of which is expressly incorporated by reference herein.

[0043] Sprayhead 10 is coupled to neck 32 of faucet body 14 by magnetic coupling 15. Magnetic coupling 15 generally includes head connector 24 coupled to sprayhead 10 and body connector 36 coupled to neck 32 of faucet body 14. As described in further detail below, head connector 24 and body connector 36 are adapted to releasably engage with one another to thereby releasably couple sprayhead 10 to neck 32 of faucet body 14.

[0044] Turning now to FIGS. 4 and 5, sprayhead 10 includes aerator 16, waterway member 18, check valves 20a and 20b, shell 22, head connector 24 and retaining nut 26. Aerator 16 is received in and coupled to dispensing end 18b of

waterway member 18. Check valves 20a, 20b are received in and coupled to threaded receiving end 18a of waterway member 18. The assembly of aerator 16, waterway member 18 and check valves 20a, 20b are disposed within shell 22. Shell 22 includes receiving end 22a and opposing dispensing end 22b. Tab 21 protrudes from receiving end 22a and, as discussed in further detail below, serves to align head connector 24 on receiving end 22a of shell 22. When the assembly of aerator 16, waterway member 18 and check valves 20a, 20b is disposed in shell 22, threaded receiving end 18a extends through opening 19 in receiving end 22a of shell 22. Threaded receiving end 18a of waterway member 18 also extends through opening 23 of head connector 24 and receives retaining nut 26, which secures head connector 24 to shell 22. Threaded receiving end 18a of waterway member 18 then extends from nut 26 and is fluidly coupled with water supply line 12.

[0045] Turning to FIGS. 5 and 7A-7E, head connector 24 is substantially ring-shaped and includes top surface 24a, opposing bottom surface 24b and opening 23 extending there-through from top surface 24a to bottom surface 24b. Opening 23 is sized to receive threaded receiving end 18a of waterway member 18 therethrough. Notch 25 is cut into bottom surface 24b and is configured to receive tab 21 of shell 22 to facilitate proper angular orientation therebetween.

[0046] Referring now to FIGS. 4 and 6A-6E, body connector 36 is disposed within dispensing end 32a of neck 32. A portion of neck 32 extends past body connector 36 to form collar 34, which is configured to removably and concentrically receive therein head connector 24 and receiving end 18a of waterway member 18. Body connector 36 includes opening 38, which extends through body connector 36 and is configured to receive receiving end 18a of waterway member 18 there-through. Body connector 36 includes base 36a and connecting element 36b. Base 36a illustratively serves to couple body connector 36 to faucet body 14, while connecting element 36b interacts with head connector 24 to releasably couple sprayhead 10 to faucet body 14, as is described in further detail below.

[0047] Base 36a includes resilient clip or snap finger 43 extending upwardly and outwardly therefrom. Slot 45 extends through neck 32 of faucet body 14 and is configured to receive clip 43. Clip 43 is snap-received within slot 45 to secure body connector 36 in neck 32 of faucet body 14. Recess 39 extends into and about a portion of the inner periphery of base 36a. Lip 41 extends from and about a portion of the outer periphery of connecting element 36b. Lip 41 is configured to engage with recess 39 to thereby couple connecting element 36b to base 36a. Base 36a may be formed of any suitable material.

[0048] Body connector 36 need not include two separate components. Rather base 36a and connecting element 36b may be integrally formed as a single unit, such that body connector 36 is one piece. In one embodiment, base 36a is formed of polymers and is at least partly overmolded to connecting element 36b. In another embodiment, base 36a is fully overmolded to connecting element 36b and encapsulates connecting element 36b. Overmolding is configured to protect the connecting elements from corrosion due to contact with fluids including water. Alternatively, corrosion may be prevented by coating or plating connecting elements. However, coatings and plating materials may be brittle and may crack due to the compressive forces that impinge on connecting elements when they are pressed into the faucet head or body. Cracking tendencies are exacerbated by large fluid

temperature differences which may range from about 32° F. to about 212° F. in various faucet applications. In one embodiment, base **36a** is formed of glass-filled polypropylene. Glass-filled polypropylene flows well in an injection-molding die and has good rigidity characteristics so that thin overmolding layers may be produced. In another embodiment, base **36a** is formed of acetal. Acetal has good hysteresis characteristics and resists flexing fatigue.

[0049] Overmolding might create a larger gap between the connecting elements than that created by coating or plating. Gaps reduce the magnetic attractive force between connecting elements in proportion to the gap distance. The magnetic flux density of a magnetic connecting element, which corresponds to the attractive force, may be increased by increasing its surface area, thickness, or magnetic material to compensate for the increased gap. These options are generally accompanied by increases in cost. Also, an application may be size-constrained for practical or aesthetic reasons. In the case of a kitchen, bath or roman-tub faucet, products must be aesthetically pleasing and must fit within standardized openings provided in sinks, tubs and other faucet support devices.

[0050] Magnets have magnetic fields characterized by their strength and orientation. Magnetic poles are limited regions in the magnet at which the field of the magnet is most intense, each of which is designated by the approximate geographic direction to which it is attracted, north (N) or south (S). The direction of the magnetic field is the direction of a line that passes through the north and south poles of the magnet. Generally, the direction is perpendicular to the magnetic surface of the magnet. The orientation of the field may be characterized as the direction pointed to by the north pole of the magnet.

[0051] Magnets may be characterized in several different ways. For instance, the magnet type may be a permanent magnet or an electromagnet. A permanent magnet exhibits a permanent (i.e. constant) magnetic field. An electromagnet generates a magnetic field only when a flow of electric current is passed through it. The magnetic field generated by the electromagnet disappears when the current ceases.

[0052] Magnets with a single magnetic field are considered dipolar because they have two poles, a north and a south pole. The magnetic field of a dipolar magnet may interact with the magnetic field of other magnets to produce a repelling or an attracting force. The magnetic field may also interact with certain attractable materials, such as iron or steel, that are naturally attracted to magnets.

[0053] The strength of the attracting or repelling magnetic force is determined by the strength of the magnetic field of the magnet and by the degree of interaction between the magnetic field and a component that enters the field. The strength of a magnetic field is determined by the construction of the magnet. The strength of an electromagnetic field can be changed by changing the current that flows through the electromagnet. The degree of interaction is determined by the size of the magnetic surface that interacts with the component entering the field and by the distance between the magnet and the component entering the field. The magnetic force of a magnet, therefore, may be changed by changing the position of the magnet relative to another magnet or to the attractable material.

[0054] A backing element may increase the attractive force of a magnetic coupling. Referring now to FIGS. **11A** and **11B**, the magnetic flux densities of two magnetic fields are conceptually represented by magnetic flux lines **306a** and **306b**.

FIG. **11A** shows magnet **300** having magnetic flux lines **306a** that extend from both surfaces **302**, **304** connecting its north and south poles. Spaced-apart surfaces **302**, **304** define the thickness of magnet **300**. At points P_{N1} and P_{S1} located at a distance D_1 perpendicularly away from surfaces **302** and **304**, respectively, on centerline **310**, the magnetic field equals F gauss.

[0055] FIG. **11B** shows magnet **300** coupled to backing element **308**, and having flux lines **306b** that extend from surface **302** to and through backing element **308** to surface **304** connecting its north and south poles. At points $PN2$ and $PS2$ located at corresponding distances $D2$ and $D3$ perpendicularly away from surfaces **302** and **304**, respectively, on centerline **310**, the magnetic field also has a value equal to F gauss. $D2$ is greater than both $D1$ and $D3$ meaning that the magnetic field strength changed as a result of the addition of backing element **308** and that backing element **308** increased the strength of the magnetic field at point $PN1$ a distance $D1$ perpendicularly away from surface **302**. A suitable backing element may be a plate comprising steel, iron, and other non-magnetic magnetically attractive materials. Depending on the selection of materials and particular designs, the magnetic flux density at a distance away from the surface of magnet **300** may be increased more by the addition of backing element **308** than by an increase in the thickness of magnet **300** equal to the thickness of backing element **308**. Thus, a stronger attractive force may be achieved with a smaller, less costly, corrosion resistant connector.

[0056] Exemplary embodiments of connectors having overmolded connecting elements and backing elements are shown in FIGS. **12A**, **12B**, **13A**, **13B** and **13C**. Referring now to FIGS. **12A** and **12B**, an alternative faucet head **312** comprises a body **314** having an opening **322**, a head connector **324** and a dispensing portion **318**. Head connector **324** is explained in detail with reference to FIGS. **13A** and **13B**. Body **314** includes lever **316** adapted to activate waterflow valve **320** to dispense water. Head connector **324** couples to water dispensing portion **318** by means of clips **325**. FIG. **13B** is a partial cross-sectional view of body **314** showing head connector **324** positioned on dispensing portion **318** and having surface **330** protruding through opening **322**.

[0057] FIGS. **13A** and **13B** show magnetic coupling **315** comprising a pair of connectors. While either connector may be positioned in a body or head of a faucet, connector **336** will be described as a body connector and connector **324** will be described as a head connector for ease of explanation.

[0058] Body connector **336** includes opening **338** extending through it and being configured to receive a water supply line therethrough. Body connector **336** includes base **336a**, connecting element **336b**, and backing element **336c**. Body connector base **336a** is overmolded to encapsulate connecting element **336b** and backing element **336c**. Body connector base **336a** further includes clip or snap finger **343**. Body connector base **336a** has an external profile **340** having ribs **342** designed to fit tightly inside the neck of a faucet. Optionally, body connector base **336a** has an outwardly protruding lip **345** designed to fit against the edge of the receiving end of the neck of a faucet without a collar. Body connector base **336a** encapsulates connecting element **336b** with material disposed over a surface **346**, the encapsulating layer having a spaced-apart external surface **348** defining a layer thickness **350**.

[0059] In another embodiment, body connector **336** does not have a lip and fits inside neck **32** as a suitable replacement

for body connector 36. An embodiment of connector 336 without lip 345 is shown in FIG. 13C and denoted as connector 336'. Connector 336' includes base 336a', connecting element 336b', and backing element 336c'. Body connector base 336a' is overmolded to encapsulate connecting element 336b' and backing element 336c'. Body connector base 336a' further includes clip or snap finger 343'.

[0060] FIGS. 13A and 13B also show head connector 324. Head connector 324 includes opening 328 extending through it and being configured to receive water dispensing portion 318 therethrough. Head connector 324 includes base 324a, connecting element 324b, and backing element 324c. Head connector base 324a is overmolded to encapsulate connecting element 324b and backing element 324c. Head connector base 324a further includes clips 325 for securing head connector 324 to water dispensing portion 318. Head connector base 324a encapsulates connecting element 324b with material disposed over a surface 332, the encapsulating layer having a spaced-apart external surface 330 defining a layer thickness 334.

[0061] Backing elements 336c and 324c focus the magnetic fields to increase the attractive force and compensate for the loss of force created by gap 352. In one embodiment, a pulling force of between 2 and 12 pounds is required to pull apart head connector 324 from body connector 336. In a further illustrative embodiment, the pulling force required to separate head connector 324 from body connector 336 is between 3 and 8 pounds. In yet another illustrative embodiment, the pulling force is between 3.5 and 6 pounds. In one embodiment, each of connectors 336 and 324 have a coupling surface area between 0.4 and 2.0 square inches. In another embodiment, each of connectors 336 and 324 have a coupling surface area between 0.5 and 1.0 square inches. In one embodiment, each of connectors 336 and 324 have a magnetic field of between 400 and 2000 gauss tested at 0.090 inches. In another embodiment, each of connectors 336 and 324 have a magnetic field of between 500 and 1000 gauss tested at 0.090 inches. In one embodiment, the gap is in a range between 0.00 and 0.01 inches. In another embodiment, the gap is in a range between 0.040 and 0.080 inches. In one embodiment, the magnetic couplings satisfy the 24 hour CASS salt sprayer test according to ASTM-368. Each of connectors 324, 336 may be dipolar or multipolar.

[0062] Backing elements 336c and 324c focus the magnetic fields to increase the attractive force and compensate for the loss of force created by gap 352. In one embodiment, a pulling force of between 2 and 12 pounds is required to pull apart head connector 324 from body connector 336. In a further illustrative embodiment, the pulling force required to separate head connector 324 from body connector 336 is between 3 and 8 pounds. In yet another illustrative embodiment, the pulling force is between 3.5 and 6 pounds. In one embodiment, each of connectors 336 and 324 have a coupling surface area between 0.4 and 2.0 square inches. In another embodiment, each of connectors 336 and 324 have a coupling surface area between 0.5 and 1.0 square inches. In one embodiment, each of connectors 336 and 324 have a magnetic field of between 400 and 2000 gauss tested at 0.090 inches. In another embodiment, each of connectors 336 and 324 have a magnetic field of between 500 and 1000 gauss tested at 0.090 inches. In one embodiment, the gap is in a range between 0.00 and 0.10 inches. In another embodiment, the gap is in a range between 0.040 and 0.080 inches. In one embodiment, the magnetic

couplings satisfy the 24 hour CASS salt sprayer test according to ASTM-368. Each of connectors 324, 336 may be dipolar or multipolar.

[0063] Referring again to FIGS. 3, 4, 6D, 7A, 7B, 8A, and 8B, the interaction between connecting element 36b of body connector 36 with head connector 24 to releasably couple sprayhead 10 to faucet body 14 will now be described. As shown in FIGS. 6D, 7A, and 7B and diagrammatically in FIGS. 8A and 8B, head connector 24 and connecting element 36b of body connector 36 may be in the form of magnets adapted to attract one another.

[0064] Unlike-poles attract and like-poles repel. Accordingly, when two dipolar magnets come into close proximity and their magnetic fields are oriented in the same direction, they attract one another. The north pole on the proximal surface of one magnet attracts the south pole on the proximal surface of the other magnet. On the other hand, when two dipolar magnets come into close proximity and their magnetic fields are oriented in opposite directions, they repel one another. For example, the north pole on the proximal surface of one magnet repels the north pole on the proximal surface of the other magnet.

[0065] Magnets may also include multiple magnetic fields with some fields oriented in a first direction and other fields oriented in a second direction that is opposite the first direction. When two multi-field magnets come in close proximity to one another, they will repel one another if the multiple fields are not oriented in the same direction and will attract one another if they are oriented in the same direction. Multi-field magnets provide two modes of operation: an attracting mode and a repelling mode. Couplings including multi-field magnets may be referred to as bi-modal couplings.

[0066] As shown in FIGS. 8A and 8B, magnetic coupling 15 may be bi-modal in that it includes an attracting mode (FIG. 8A) and a repelling mode (FIG. 8B), and may be adjusted between the two modes. In this case, as further shown in FIGS. 6D, 8A, and 8B, connecting element 36b of body connector 36 includes multiple magnetic fields S_1, N_1, S_2, N_2 arranged alternately in opposing directions. Similarly, as shown in FIGS. 7A, 7B, 8A, and 8B, head connector 24 includes multiple magnetic fields S_1', N_1', S_2', N_2' arranged alternately in opposite directions. With reference to FIG. 8A, in the attracting mode, head connector 24 is arranged relative to body connector 36 such that magnetic fields $S_1', N_1', S_2',$ and N_2' of head connector 24 are aligned with and oriented in the same direction as magnetic fields $S_1, N_1, S_2,$ and N_2 of body connector 36, respectively. In this orientation, when head connector 24 is brought in close proximity to body connector 36, the two are attracted to one another, as indicated by the solid-headed arrows. Turning to FIG. 8B, head connector 24 has been rotated clockwise by approximately 90 degrees, such that magnetic fields $S_1', N_1', S_2',$ and N_2' of head connector 24 are now aligned with and oriented in directions opposite to magnetic fields N_1, S_2, N_2 and $S_1,$ respectively, of body connector 36. In this orientation, when head connector 24 is brought in close proximity to body connector 36, the two are repelled from one another as indicated by the solid-headed arrows.

[0067] Referring to FIGS. 3, 4, 8A, and 8B, in practical operation of faucet 1, magnetic coupling 15 releasably couples sprayhead 10 to neck 32 of faucet body 14 using the attracting mode shown in FIG. 8A. In other words, magnetic fields $S_1, N_1, S_2,$ and N_2 of body connector 36 are respectively aligned with and oriented in the same direction as magnetic

fields S_{N_1}' , S_2' , and N_2' of head connector 24, such that head connector 24 and the remaining components of sprayhead 10 are attracted and held to body connector 36, as shown in FIG. 4. When the user desires to pull sprayhead 10 out from neck 32, the user may simply pull sprayhead 10 away from neck 32 with enough force to overcome the attracting magnetic forces between head connector 24 and body connector 36. To ease the release of sprayhead 10 from neck 32, the user may also rotate sprayhead 10 by approximately 90 degrees and, thus, head connector 24, until magnetic coupling 15 exhibits its repelling mode, shown in FIG. 8B. In other words, sprayhead 10 may be rotated until magnetic fields S_1' , N_1' , S_2' , and N_2' of head connector 24 are oriented in opposite directions relative to magnetic fields N_1 , S_2 , N_2 and S_1 of body connector 36. In this orientation, coupling 15 assists the user in pulling sprayhead 10 from neck 32 by providing a repelling force that repels head connector 24 from body connector 36.

[0068] The magnetic coupling of sprayhead 10 to body 14 may be achieved without the use of multi-field magnets. Faucet 1 may be equipped with uni-modal magnetic coupling 115 through the use of dipolar magnets, as schematically illustrated in FIG. 9. Magnetic coupling 115 includes head connector 124 and body connector 136, which may be respectively coupled to sprayhead 10 and body 14 in a manner similar to that of magnetic coupling 15 described above. Head connector 124 includes only one magnetic field N, while body connector 136 includes only one magnetic field N', which is oriented in the same direction as magnetic field N. Accordingly, when the sprayhead 10 is brought in close proximity to neck 32 of faucet body 14, body connector 136 attracts and holds head connector 124 thereto. To release sprayhead 10 from neck 32, the user pulls sprayhead 10 away from neck 32 with enough force to overcome the attractive force between body connector and head connectors 136 and 124.

[0069] The magnetic coupling need not employ two magnets. For instance, as schematically illustrated in FIG. 10, magnetic coupling 215 includes body connector 236, which is a dipolar magnet having single magnetic field N, and head connector 224, which is formed of a magnetically attractable material, such as iron or steel. Head connector 224 and body connector 236 may be coupled to sprayhead 10 and neck 32, respectively, in a manner similar to that of connectors 24, 36 described above. Sprayhead 10 is releasably held to neck 32 of faucet body 14 by the attractive force between magnetic body connector 236 and attractable head connector 224. Either one of body connector 236 or head connector 224 may be the magnet, and the other may be formed of the magnetically attractable material.

[0070] Turning now to FIGS. 14, 14A, and 14B, additional physical or structural features may be employed to guide the user in aligning and coupling the sprayhead 10 to the body 14 and releasing the sprayhead 10 from the body 14. For instance, magnetic coupling 415 includes head connector 424 and body connector 436, which may be respectively coupled to sprayhead 10 and body 14, as described above. Head connector 424 and body connector 436 may be configured like any of the embodiments described above. Body connector 436 includes male component 450 in the form of a curved ridge or protrusion. Head connector 424 includes female component 452 in the form of a curved recess configured to mate with and receive male component 450.

[0071] FIGS. 14 and 14A show head connector 424 and body connector 436 in an aligned position such that female component 452 receives male component 450. When in this

position, head connector 424 may be brought in closer proximity to body connector 436, thereby maximizing the strength of magnetic attraction.

[0072] FIG. 14B shows head connector 424 and body connector 436 in a misaligned position. In this position male member 450 separates body connector 436 from head connector 424 to thereby reduce the magnetic force therebetween and allow the user to more easily pull the sprayhead 10 from the faucet body 14. Male and female members 450 and 452 may have any shape such as rectangular or triangular. However, in this particular embodiment, the curved, sloping shape of female and male members 452 and 450 may also facilitate the user's rotation of head connector 424 relative to body connector 436 to reduce the attractive force between them. In the case where magnetic coupling 415 is a bimodal coupling, such as that in FIGS. 8A and 8B, rotation of head connector 424 relative to body connector 436 generates a repulsive force between them.

[0073] Any of the above-described embodiments may also include an electromagnet. For instance, either the head connector or the body connector may include an electromagnet switchable between an energized state and a de-energized state. As illustrated in FIGS. 15A and 15B, magnetic coupling 515 includes head connector 524 and body connector 536, which may be respectively coupled to sprayhead 10 and body 14 in the manner described above. Body connector 536 includes a permanent magnetic portion 536a having magnetic field N. Head connector 524 is a permanent magnet having magnetic field N', which is oriented in the same direction as magnetic field N. Accordingly, head connector 524 attracts and holds body connector 536 thereto via the attracting forces between magnetic fields N', N, as illustrated by the solid headed arrows in FIG. 15A. Body connector 536 also includes electromagnet portion 536b, which is coupled to an energy source, such as a battery, by any known means and is capable of being energized and de-energized by any known means, such as by employing an on/off power switch. Electromagnet portion 536b, when energized, is configured to generate magnetic field S, which is oriented in the opposite direction to magnetic field N of permanent magnet portion 536a of body connector 536. Therefore, when energized, electromagnet portion 536b cancels out the attractive force between magnetic fields N, N' and illustratively repels head connector 524 from body connector 536 to, thereby, ease the release of sprayhead 10 from body 14. When not energized, electromagnet portion 536b generates no magnetic field, thereby allowing head connector 524 to be attracted and held to body connector 536. It should be noted that the electromagnet may be disposed on either of body connector 536 or head connector 524, and may be employed in any of the magnetic coupling embodiments described above.

[0074] Turning to FIG. 16, faucet 601 is illustrated. Faucet 601 is of a different design than faucet 1 of FIGS. 1-2, but may still employ any of the magnetic coupling embodiments described above. Faucet 601 includes body 614 and sprayhead 610, which is releasably coupled to body 614. Neck or delivery spout 622 is part of sprayhead 610 and, thus, is removable from body 614 along with sprayhead 610. Sprayhead 610 includes head connector 624 and is coupled to water line 612. Body 614 includes body connector 636. Head connector 624 and body connector 636 cooperate with one another to form a magnetic coupling, such as those described above.

[0075] While this invention has been described as having an exemplary design, the present invention may be further modified within the spirit and scope of this disclosure. This application is therefore intended to cover any variations, uses, or adaptations of the invention using its general principles. Further, this application is intended to cover such departures from the present disclosure as come within known or customary practice in the art to which this invention pertains.

What is claimed is:

1. A faucet comprising:
 - a supply hose adapted to supply water;
 - a faucet head fluidly coupled to the supply hose and adapted to dispense the water;
 - a faucet spout adapted to support the dispensing member; and
 - a magnetic coupling to removably couple the faucet head to the faucet spout, the magnetic coupling including a first member supported for movement with the faucet head, and a second member supported by the faucet spout, at least one of the first member and the second member including a magnet, wherein the magnetic coupling requires between 2.0 and 12.0 pounds of force to pull the faucet head from the faucet spout.
2. The faucet of claim 1, wherein the magnet has a magnetic field of between 400 and 2,000 gauss tested at 0.090 inches.
3. The faucet of claim 1, wherein at least one of the first member and the second member includes an attracted member magnetically attracted to the magnet.
4. The faucet of claim 3, wherein the first member includes the attracted member, and the second member includes the magnet.
5. The faucet of claim 3, wherein the first member includes the magnet, and the second member includes the attracted member.
6. The faucet of claim 1, wherein the magnetic coupling includes a coupling surface having an area of between 0.4 and 2.0 inches.
7. The faucet of claim 1, wherein the magnet is at least partially overmolded with a polymer, the polymer being formed into a connector adapted to couple the magnet to one of the faucet head and the faucet spout.
8. The faucet of claim 1, wherein the magnetic coupling further includes a backing member configured to increase a magnetic flux of the magnet.
9. A faucet comprising:
 - a supply hose adapted to supply water;
 - a faucet head fluidly coupled to the supply hose and adapted to dispense the water, the faucet head including a delivery spout;

- a faucet body adapted to support the faucet head including the delivery spout, such that the faucet head extends above the faucet body; and

- a magnetic coupling to removably couple the faucet head to the faucet body, the magnetic coupling including a first member supported for by the faucet head, and a second member supported by the faucet body, at least one of the first member and the second member including a magnet.

10. The faucet of claim 9, wherein the magnetic coupling requires between 2.0 and 12.0 pounds of force to pull the faucet head from the faucet spout.

11. The faucet of claim 10, wherein the magnet has a magnetic field of between 400 and 2,000 gauss tested at 0.090 inches.

12. The faucet of claim 9, wherein at least one of the first member and the second member includes an attracted member magnetically attracted to the magnet.

13. The faucet of claim 12, wherein the first member includes the attracted member, and the second member includes the magnet.

14. The faucet of claim 12, wherein the first member includes the magnet, and the second member includes the attracted member.

15. The faucet of claim 9, wherein the magnetic coupling includes a coupling surface having an area of between 0.4 and 2.0 inches.

16. The faucet of claim 9, wherein the magnet is at least partially overmolded with a polymer, the polymer being formed into a connector adapted to couple the magnet to one of the faucet head and the faucet spout.

17. The faucet of claim 9, wherein the magnetic coupling further includes a backing member configured to increase a magnetic flux of the magnet.

18. A method of dispensing water from a faucet, the method comprising the steps of:

- fluidly coupling a faucet head to a water supply through a supply hose;

- coupling the faucet head to a faucet spout by a magnetic coupling, the magnetic coupling including a first member supported for movement with the faucet head, and a second member supported by the faucet spout, at least one of the first member and the second member including a magnet; and

- applying a force of between 2.0 and 12.0 pounds to separate the faucet head from the faucet spout.

19. The method of claim 18, wherein the magnet has a magnetic field of between 400 and 2,000 gauss tested at 0.090 inches.

20. The method of claim 18, wherein the magnet is at least partially overmolded with a polymer, the polymer being formed into a connector adapted to couple the magnet to one of the faucet head and the faucet spout.

* * * * *