



US 20140025038A1

(19) **United States**

(12) **Patent Application Publication**

**Kassab et al.**

(10) **Pub. No.: US 2014/0025038 A1**

(43) **Pub. Date: Jan. 23, 2014**

(54) **SYSTEMS, DEVICES, AND METHODS FOR TRANSEPTAL ATRIAL PUNCTURE USING AN ENGAGEMENT CATHETER PLATFORM**

(52) **U.S. Cl.**  
CPC ..... *A61B 17/3468* (2013.01)  
USPC ..... **604/510**; 604/164.1; 604/164.04

(71) Applicants: **Ghassan S. Kassab**, Zionsville, IN (US);  
**Jose A. Navia**, Buenos Aires (AR)

(57) **ABSTRACT**

(72) Inventors: **Ghassan S. Kassab**, Zionsville, IN (US);  
**Jose A. Navia**, Buenos Aires (AR)

Multichannel systems for engaging a bodily tissue and methods of using the same. In at least one embodiment of an exemplary multichannel system for engaging a tissue of the present disclosure, the system comprises an engagement catheter comprising a proximal end, a distal end, and defining a first lumen and second lumen extending between the proximal end and the distal end, an inducer sheath having a proximal portion and a distal portion, and defining a lumen extending therethrough, the inducer sheath configured for insertion into the second lumen of the engagement catheter, and a dilator defining a first channel and a second channel extending therethrough and a tapered tip at the distal end of the dilator, the dilator sized and shaped for inserted into the lumen of the inducer sheath.

(21) Appl. No.: **14/035,338**

(22) Filed: **Sep. 24, 2013**

**Related U.S. Application Data**

(63) Continuation of application No. 13/084,102, filed on Apr. 11, 2011, now Pat. No. 8,540,674.

**Publication Classification**

(51) **Int. Cl.**  
*A61B 17/34* (2006.01)

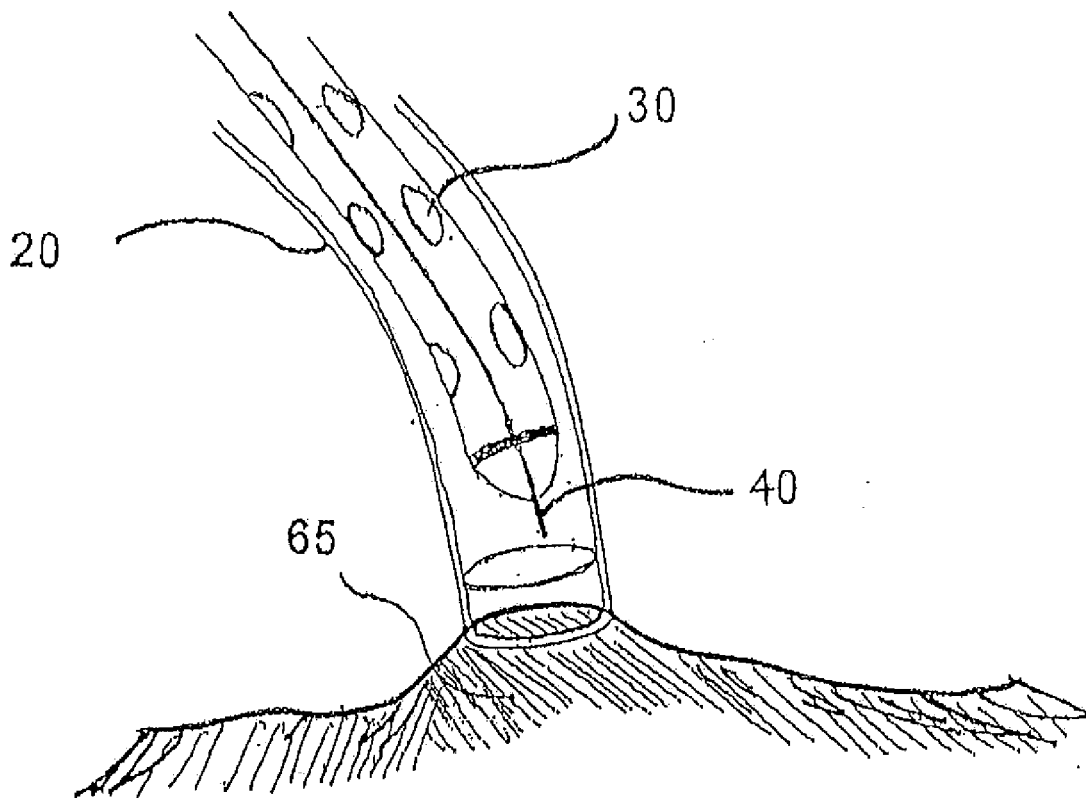

FIG. 1A

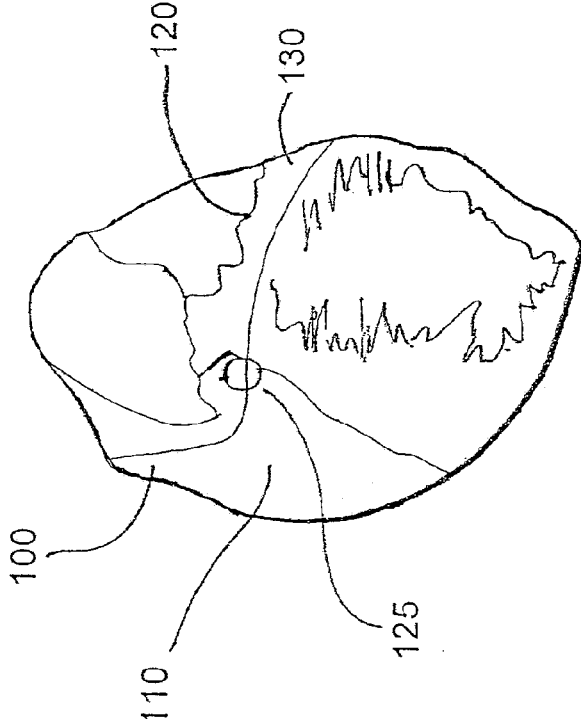
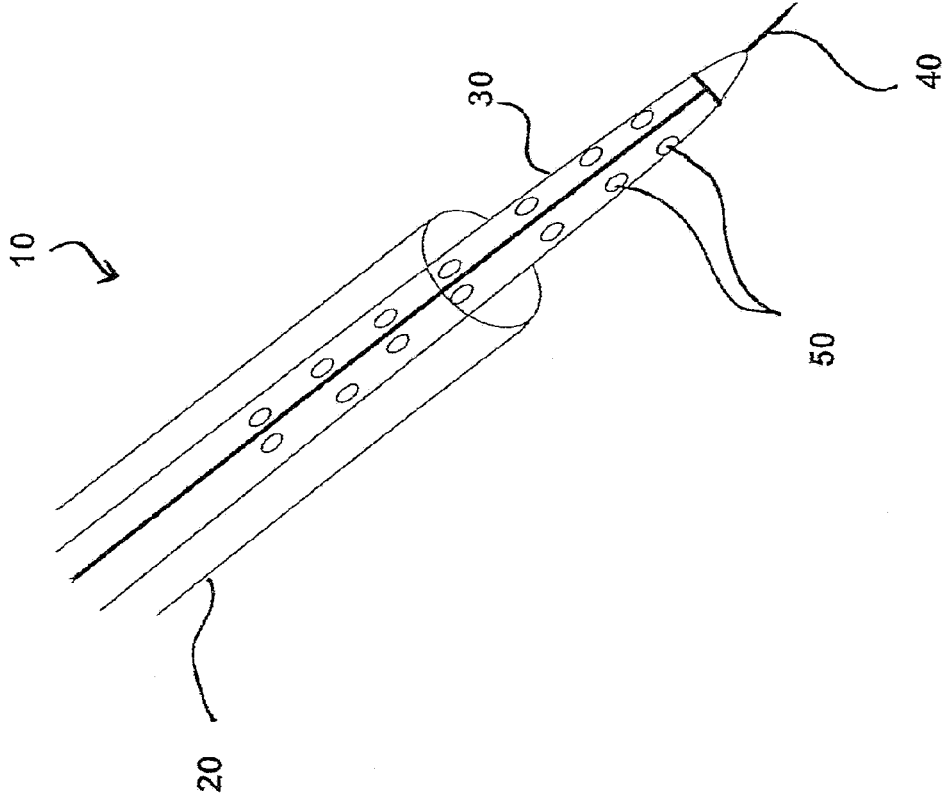

FIG. 1B

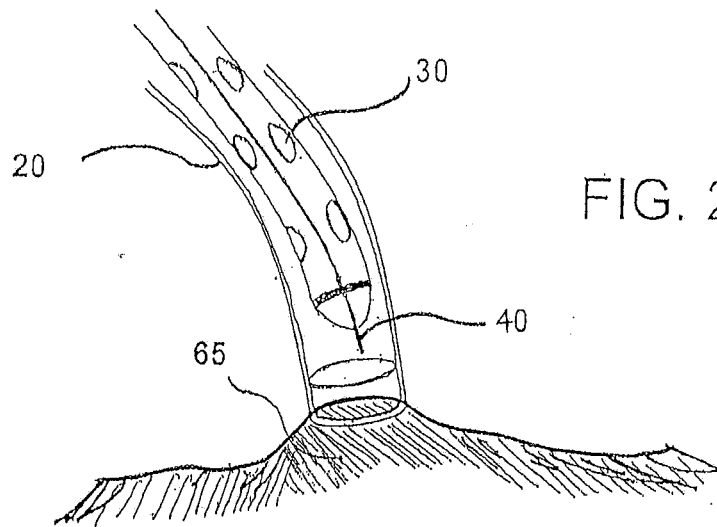

FIG. 2A

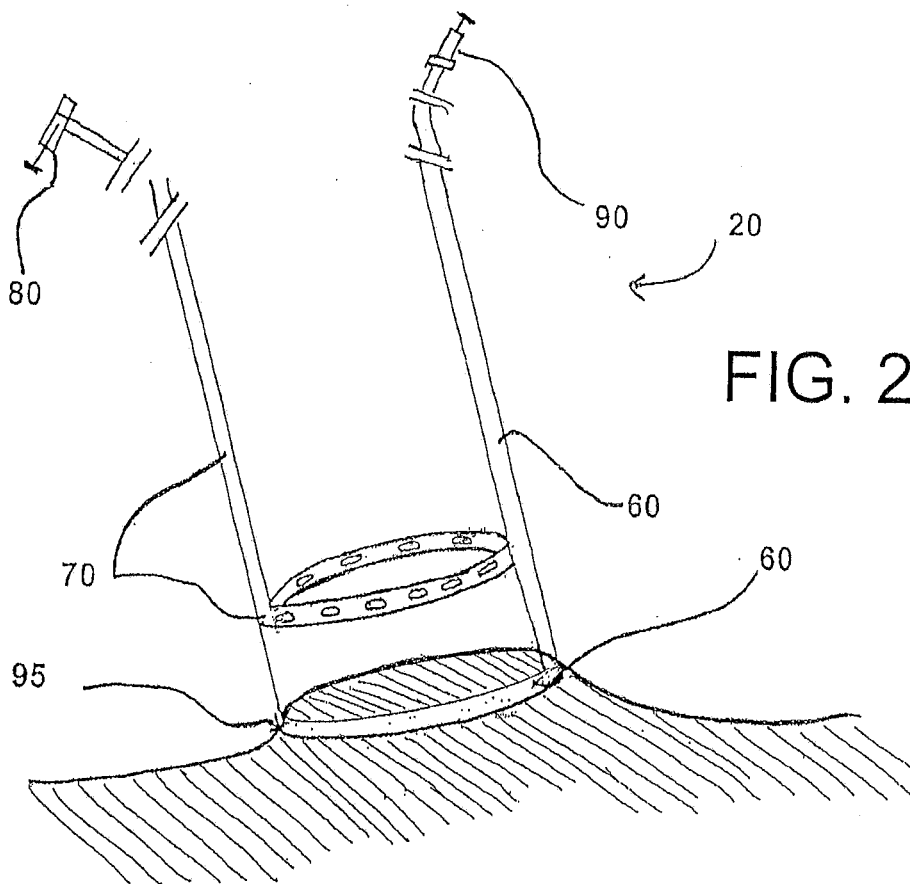
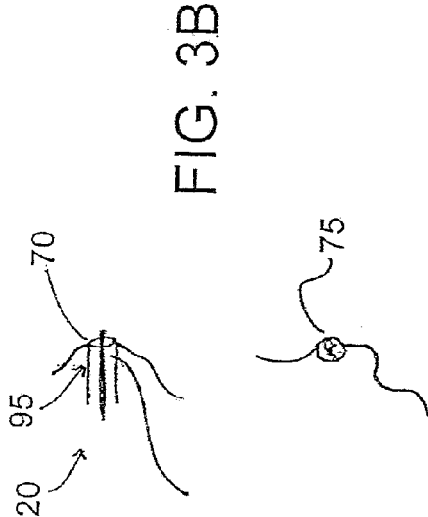
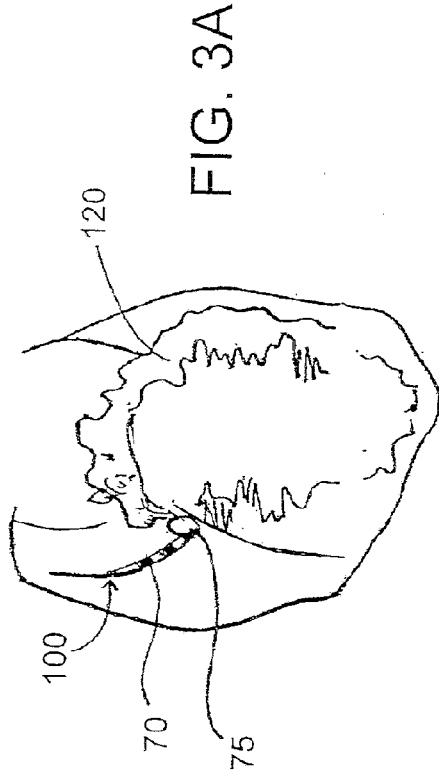
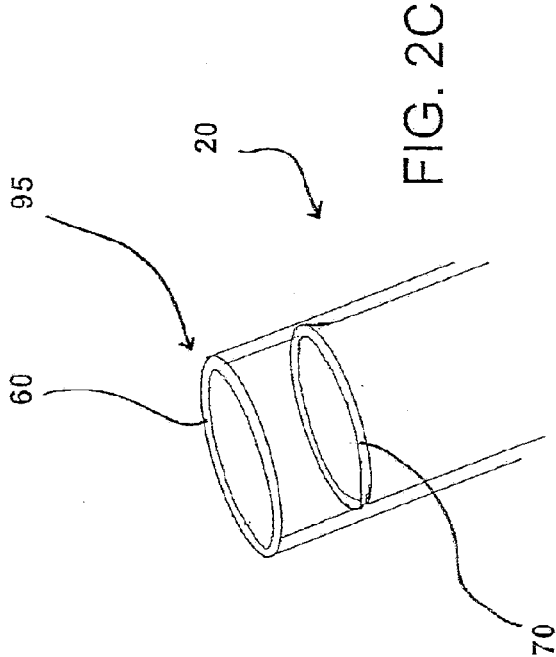

FIG. 2B



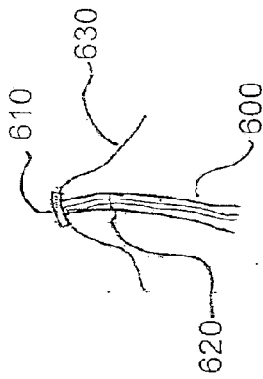

FIG. 4A

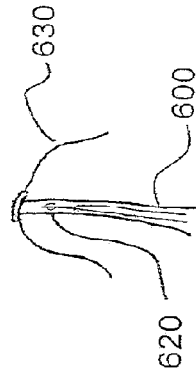

FIG. 4B

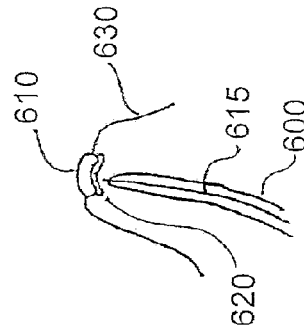

FIG. 4C

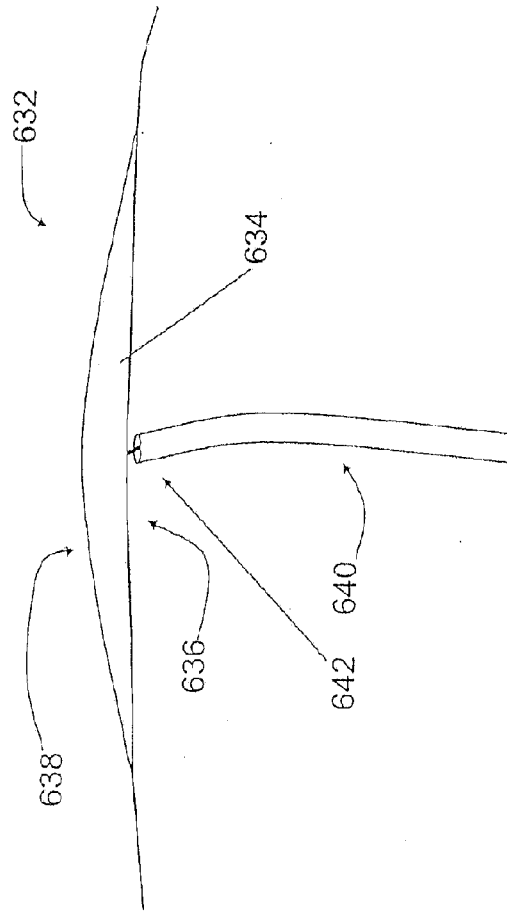
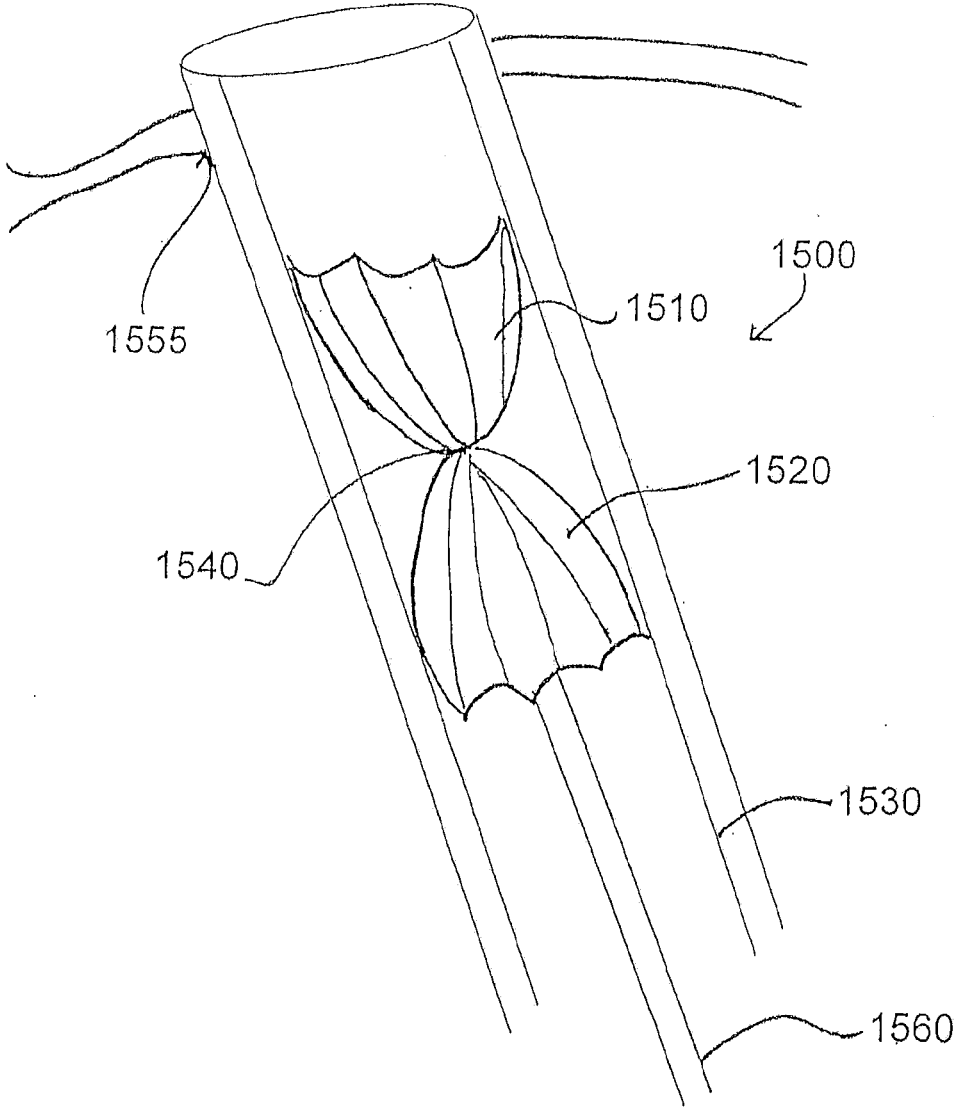

FIG. 4D

FIG. 4E



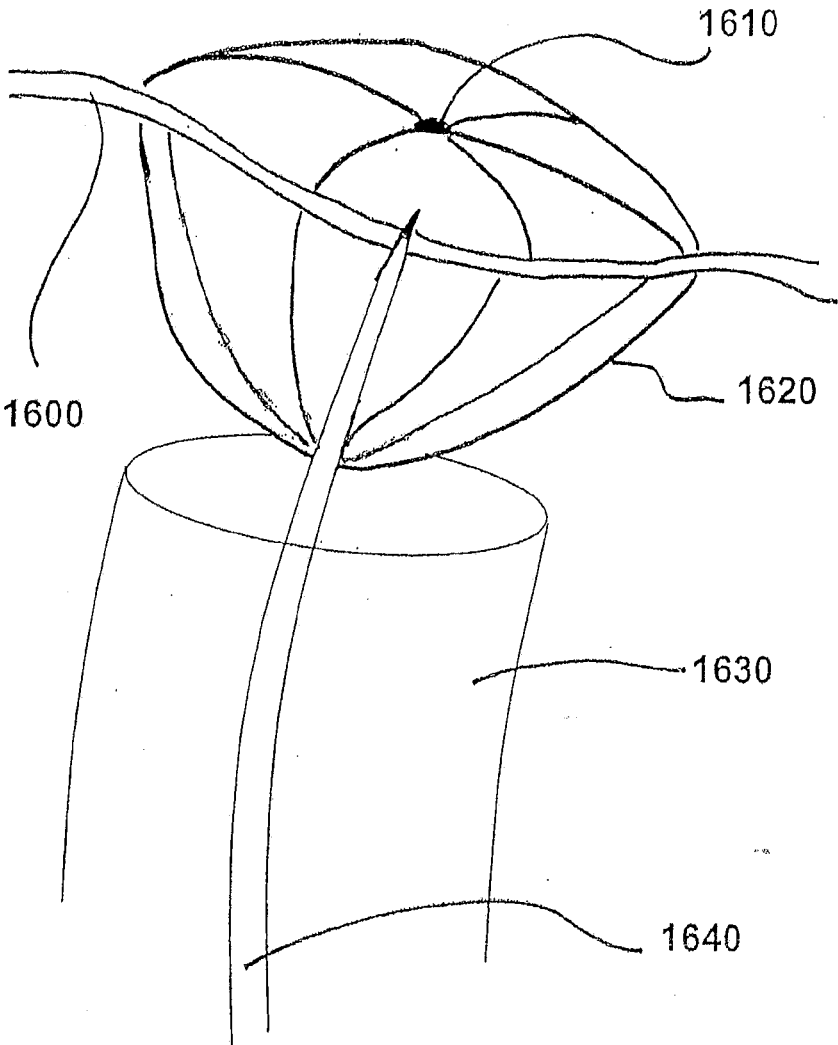

FIG. 4F

FIG. 5A

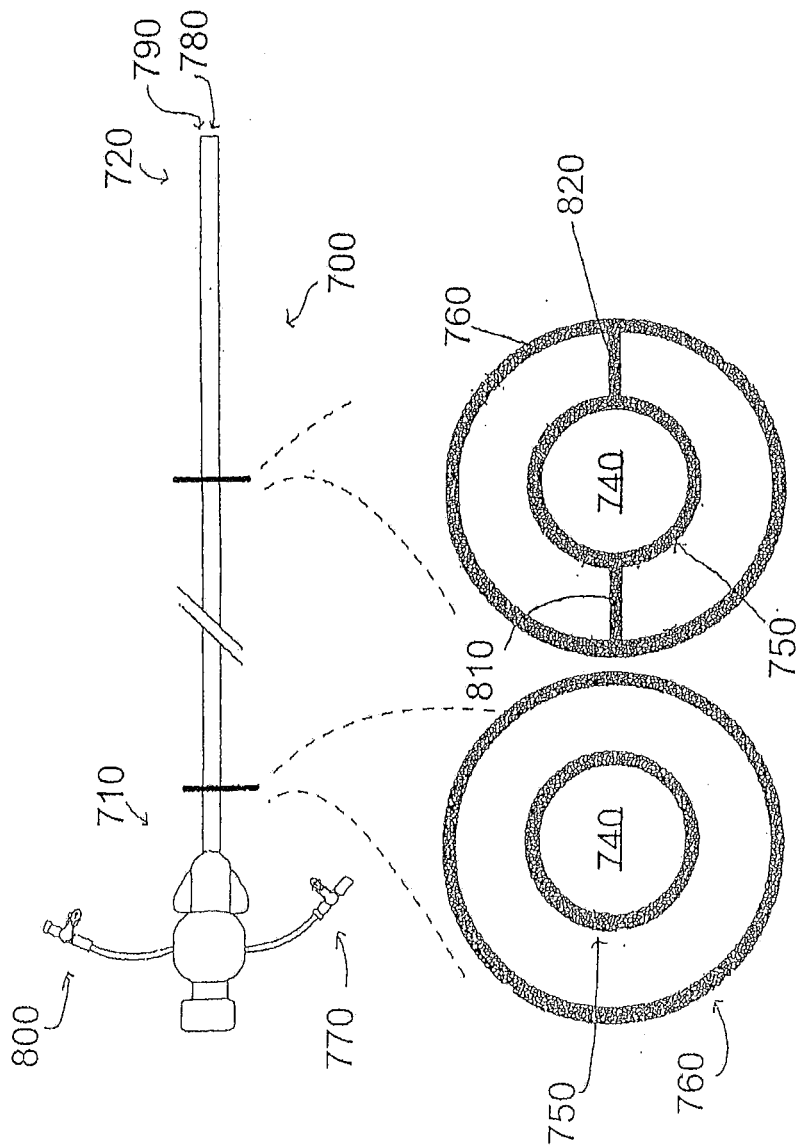

FIG. 5B

FIG. 5C



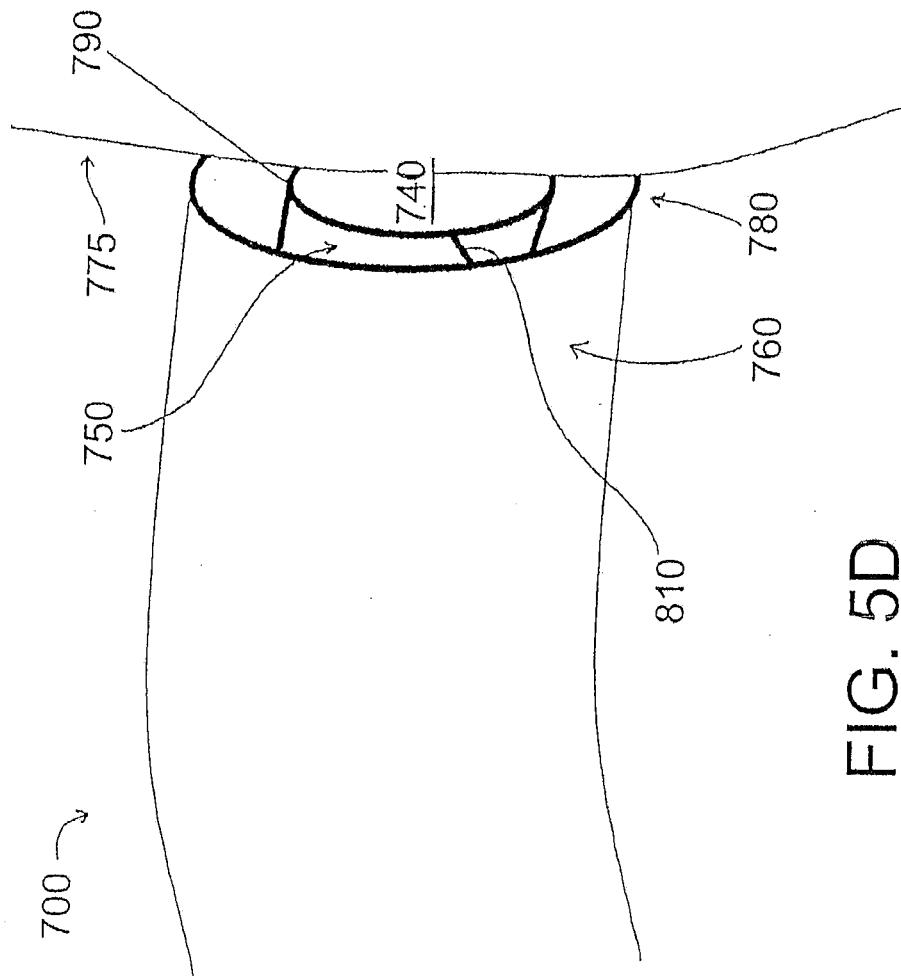

FIG. 5D

FIG. 6A

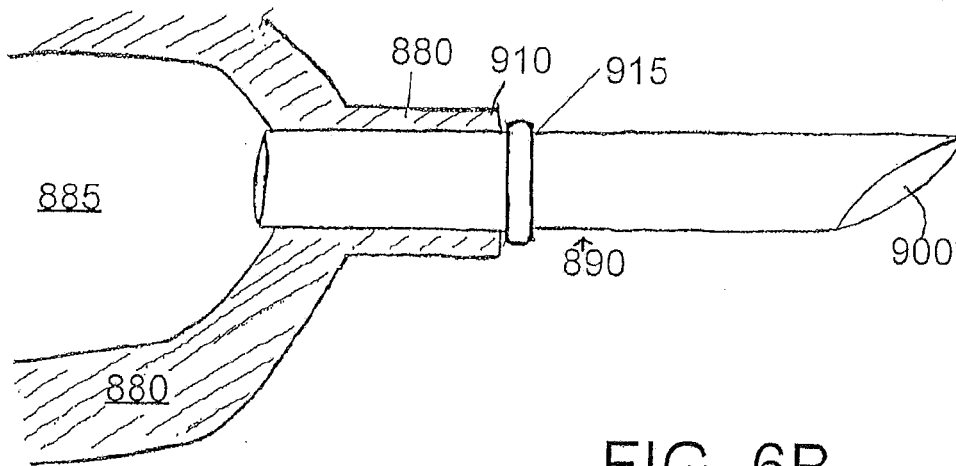
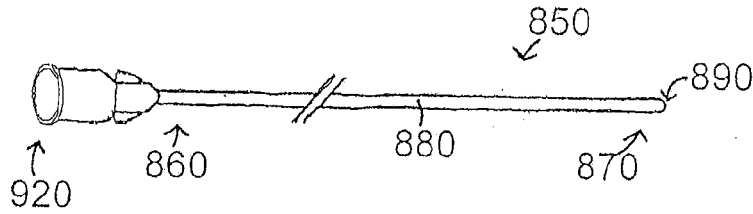

FIG. 6B

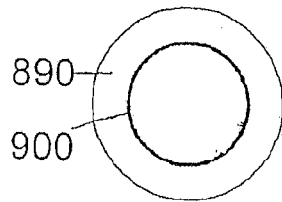

FIG. 6C

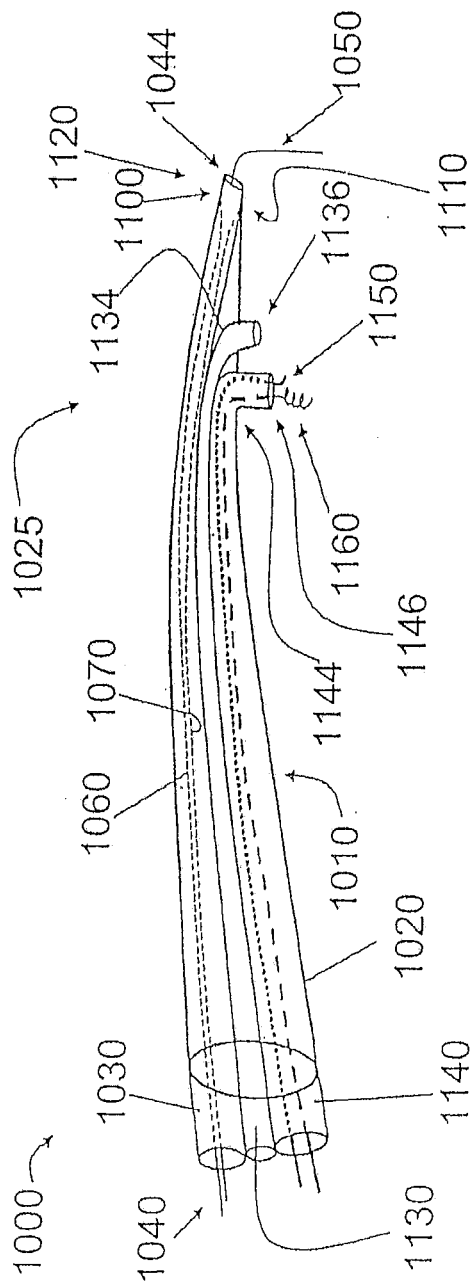

FIG. 7

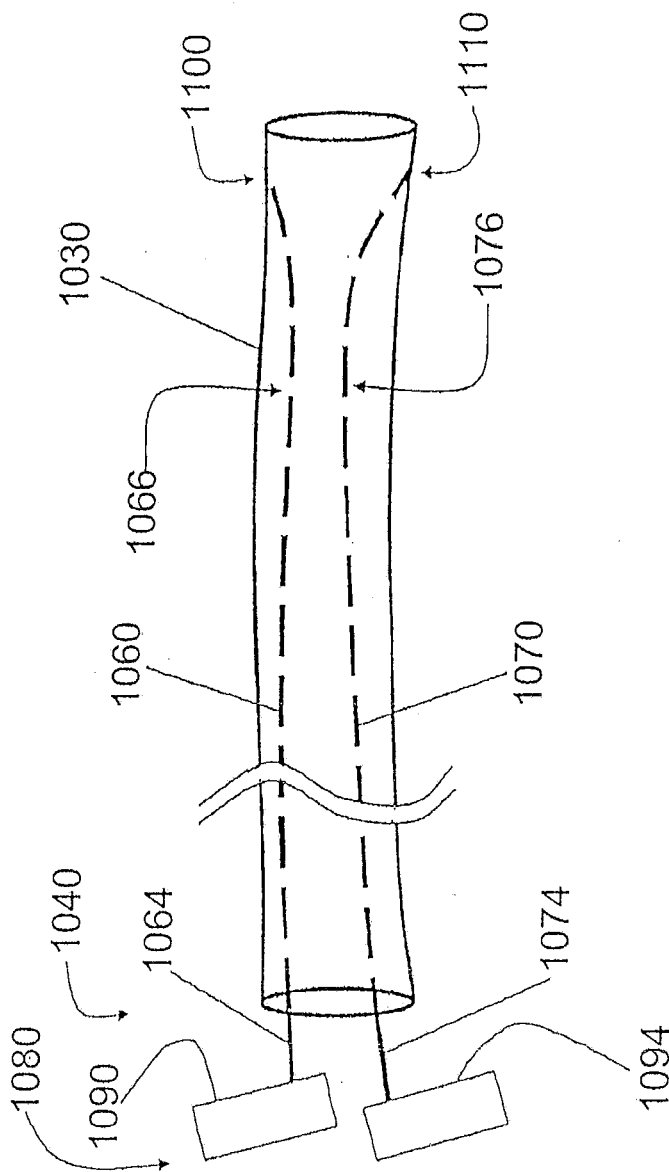

FIG. 8

FIG. 9A

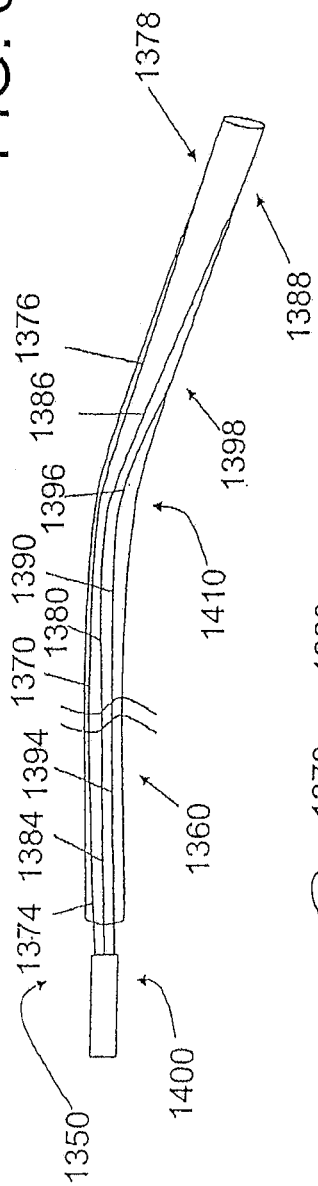

FIG. 9B

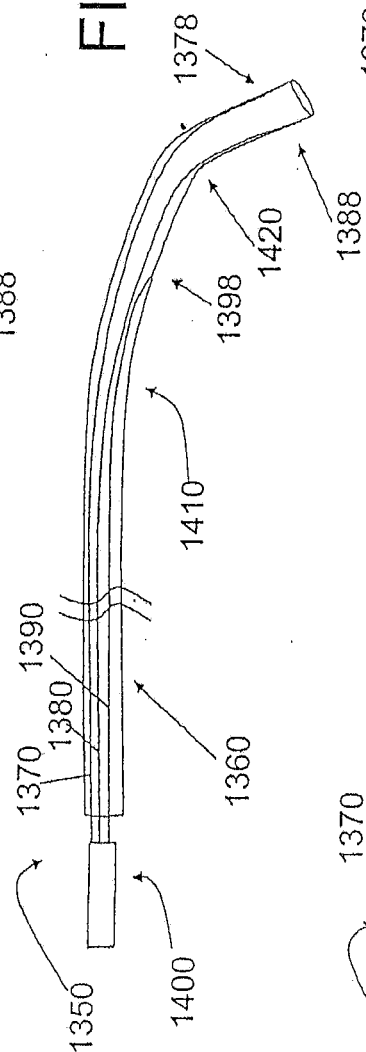
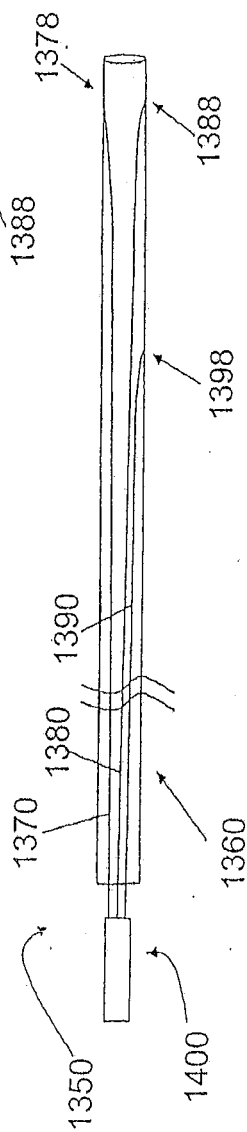

FIG. 9C



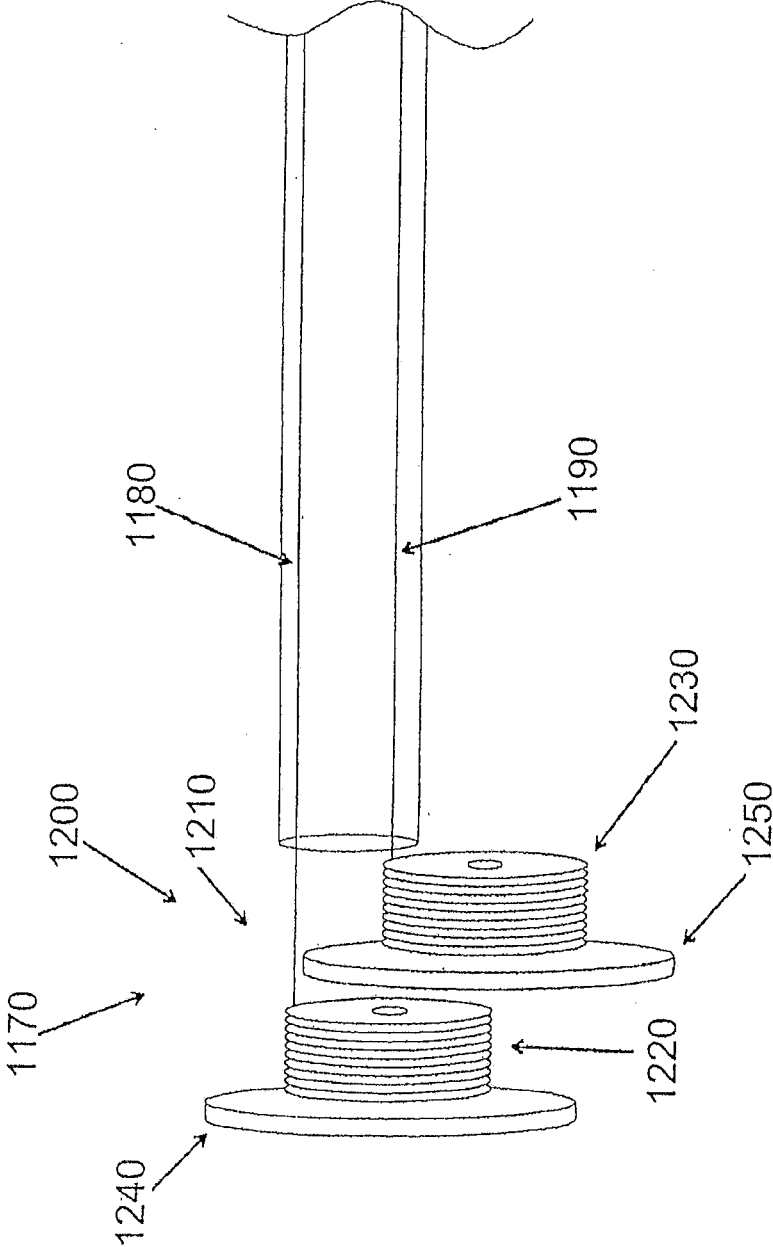

FIG. 10

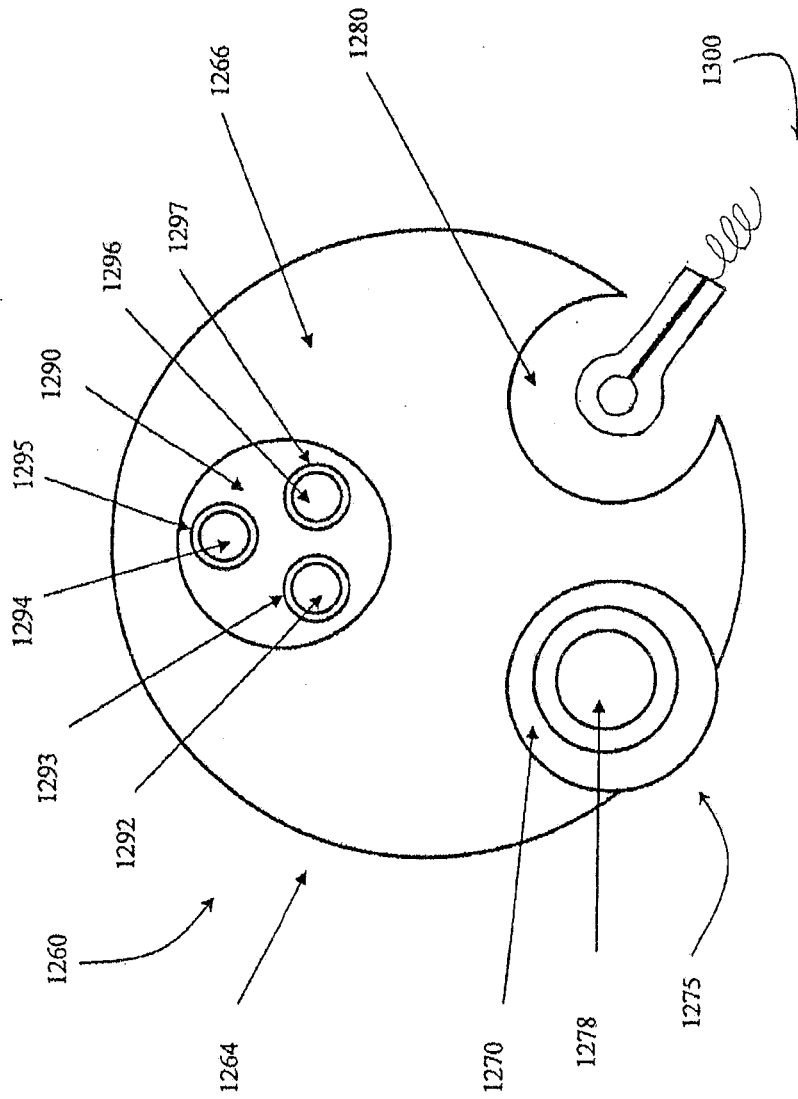

FIG. 11

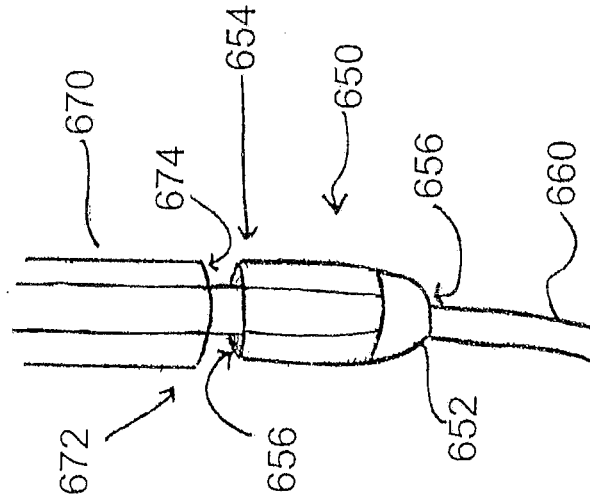

FIG. 12A

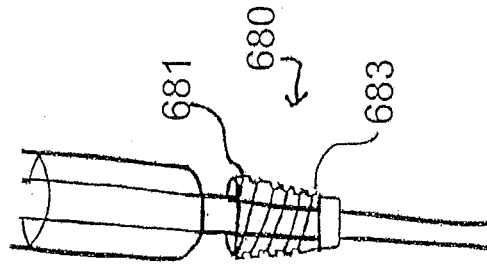

FIG. 12B

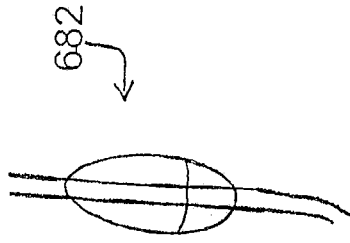

FIG. 12C



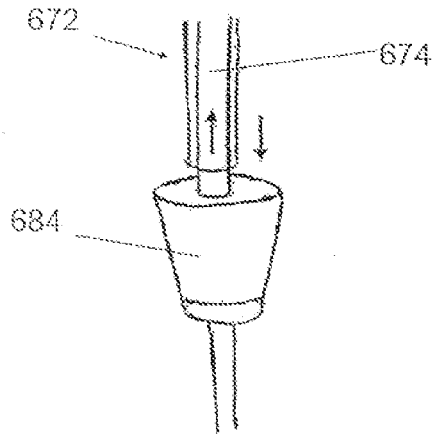

FIG. 13

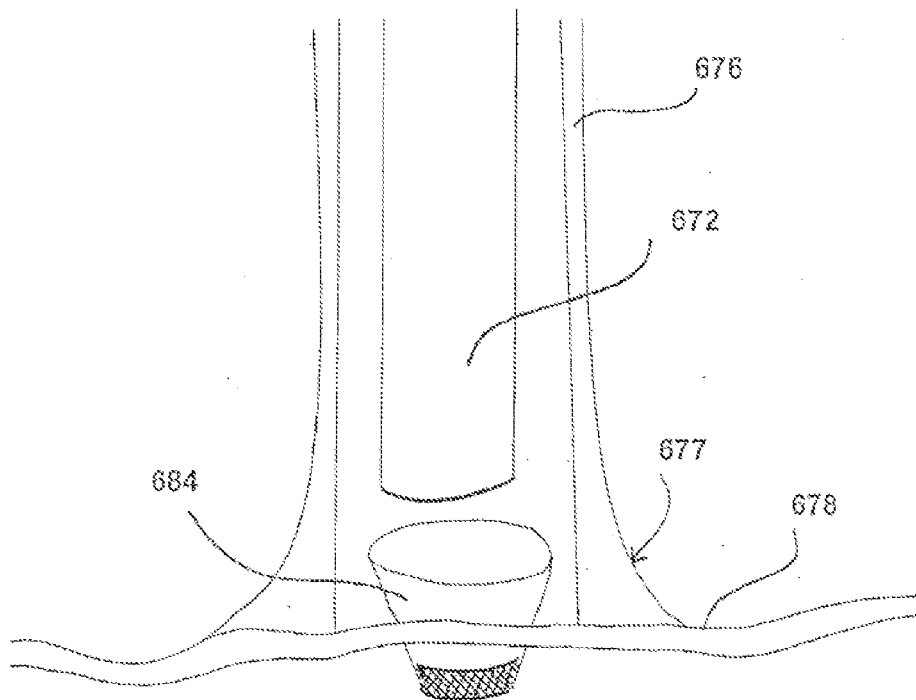

FIG. 14

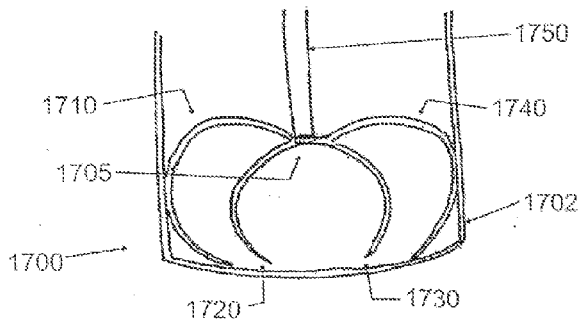

FIG. 15A

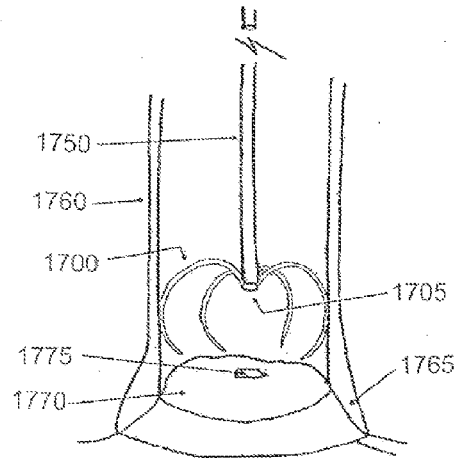

FIG. 15B

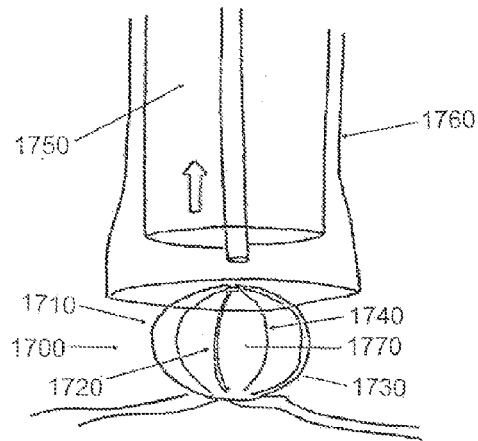

FIG. 15C

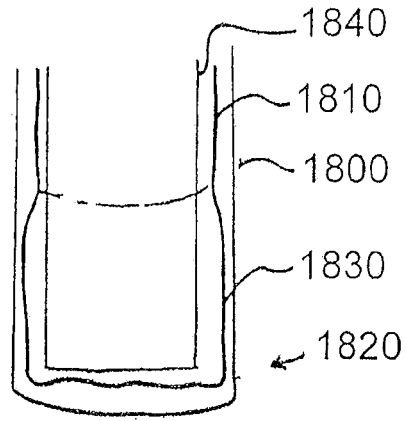

FIG. 16A

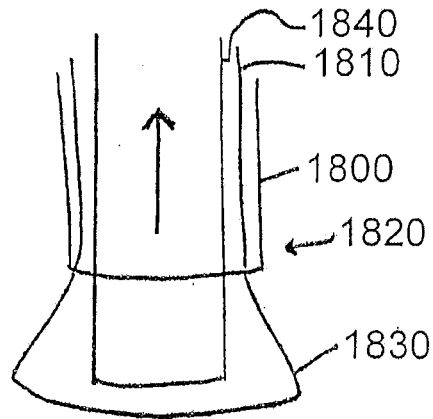

FIG. 16B

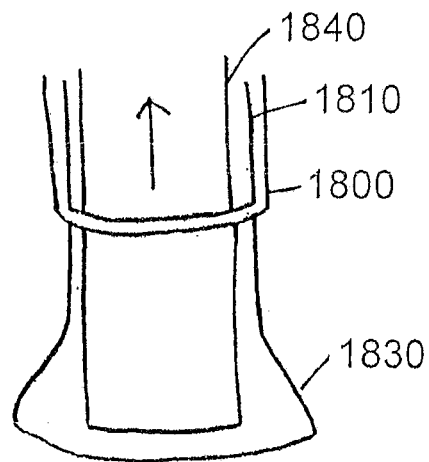

FIG. 16C

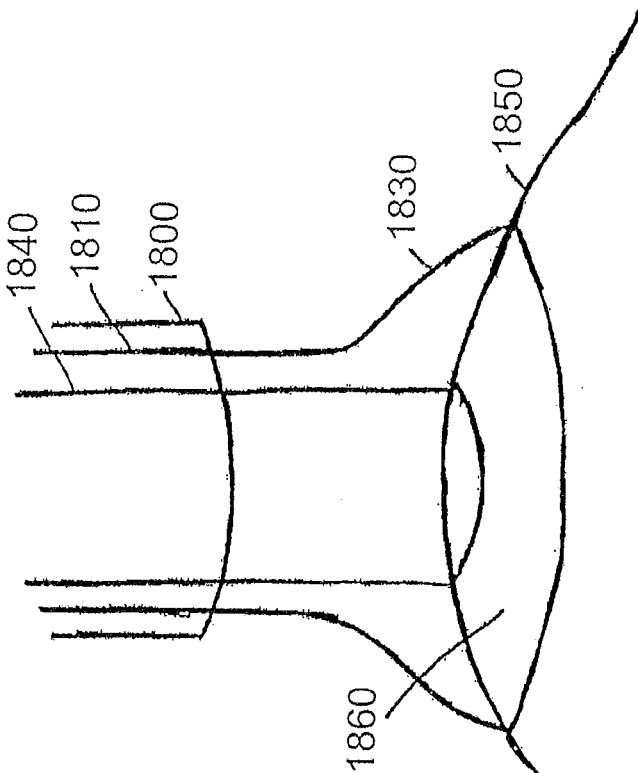

FIG. 17B

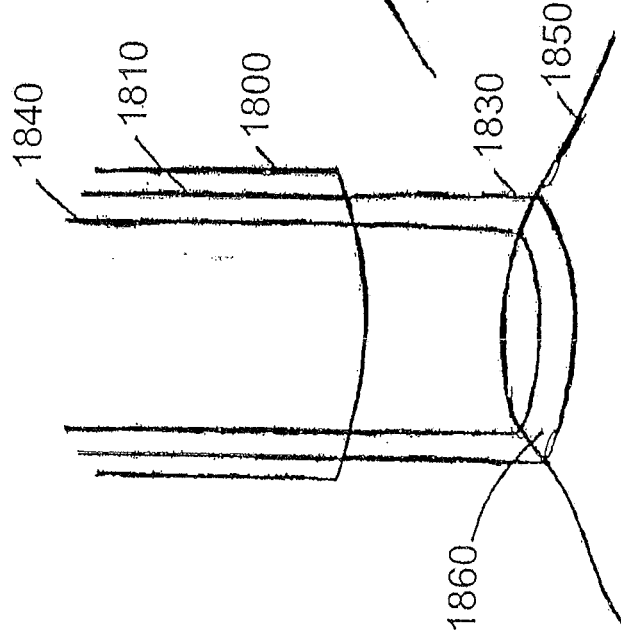

FIG. 17A

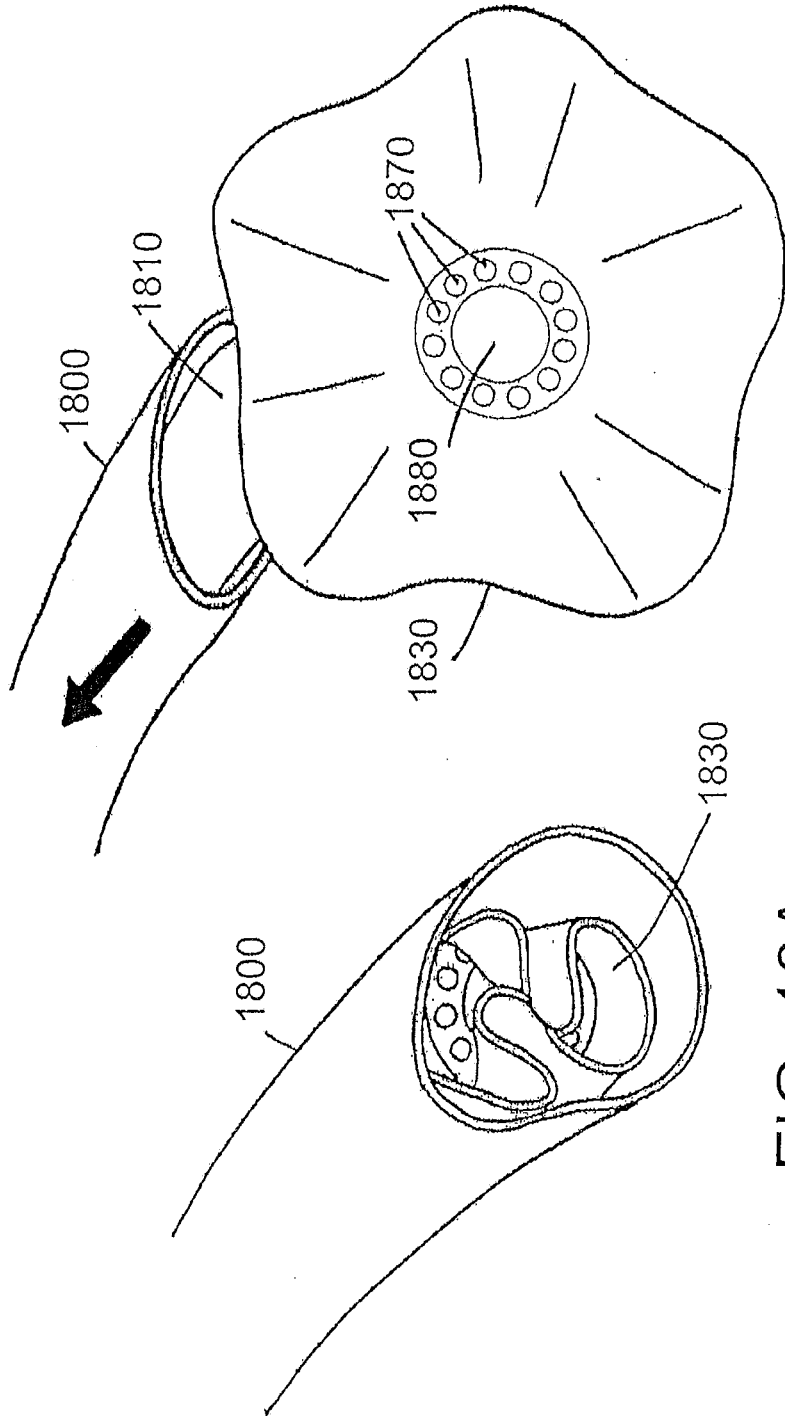

FIG. 18A

FIG. 18B

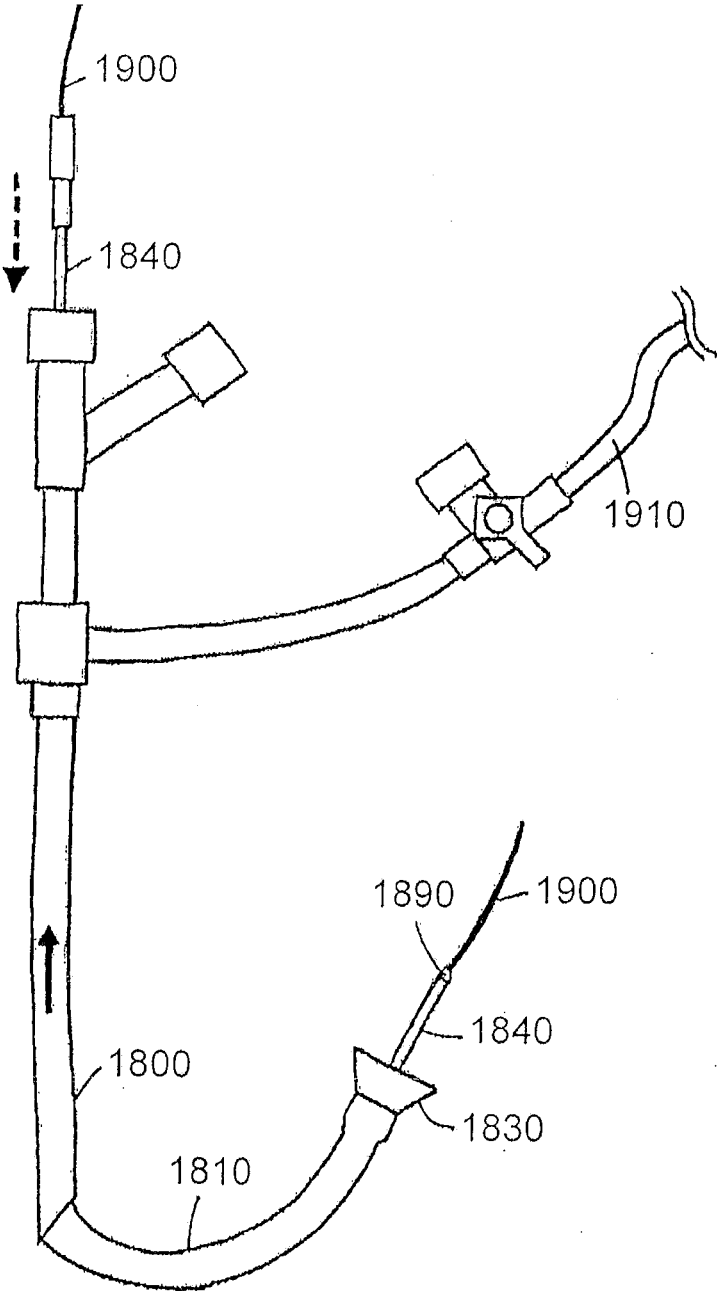

FIG. 19

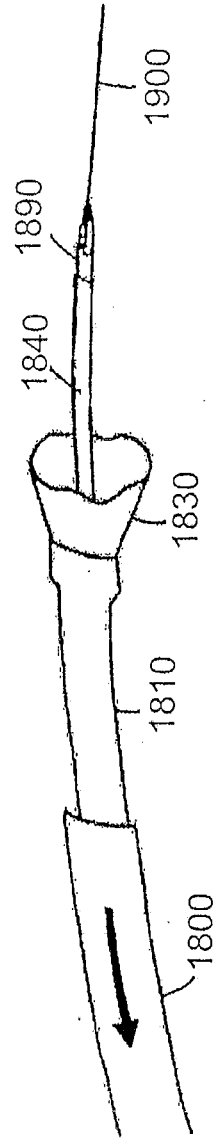

FIG. 20A

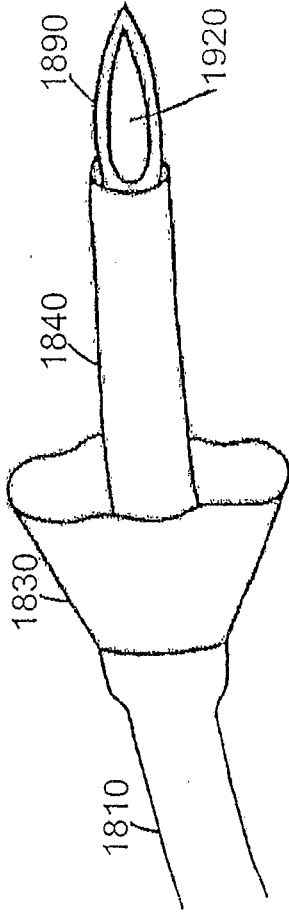

FIG. 20B

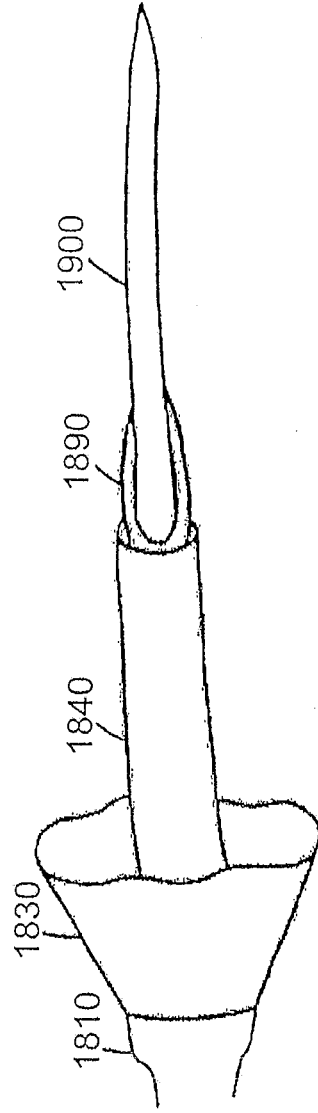

FIG. 20C

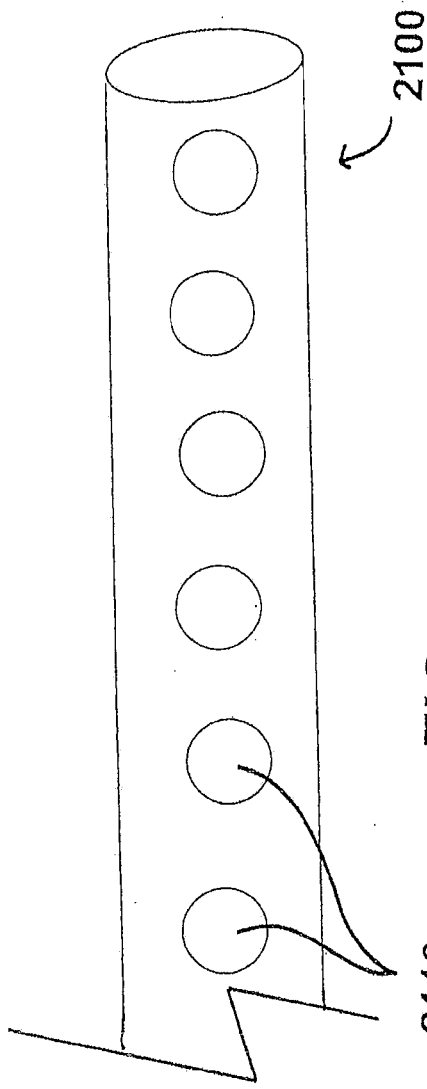

FIG. 21A

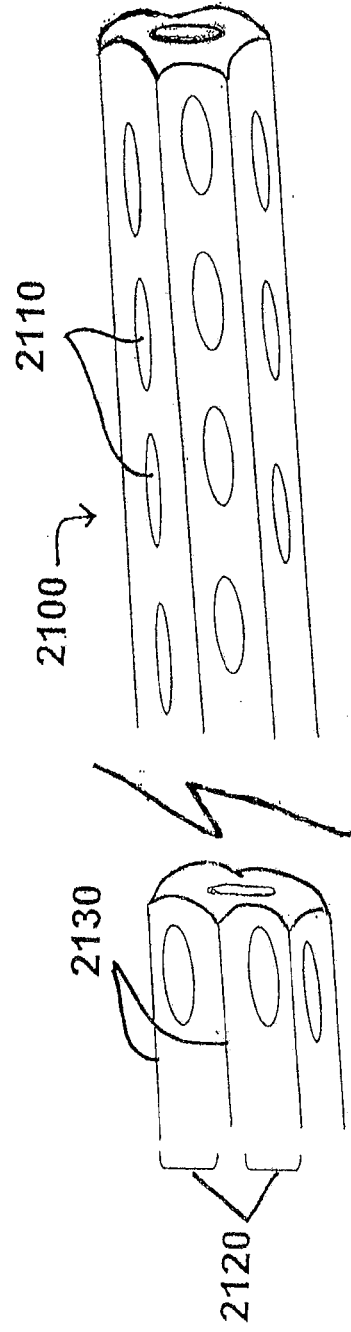

FIG. 21B



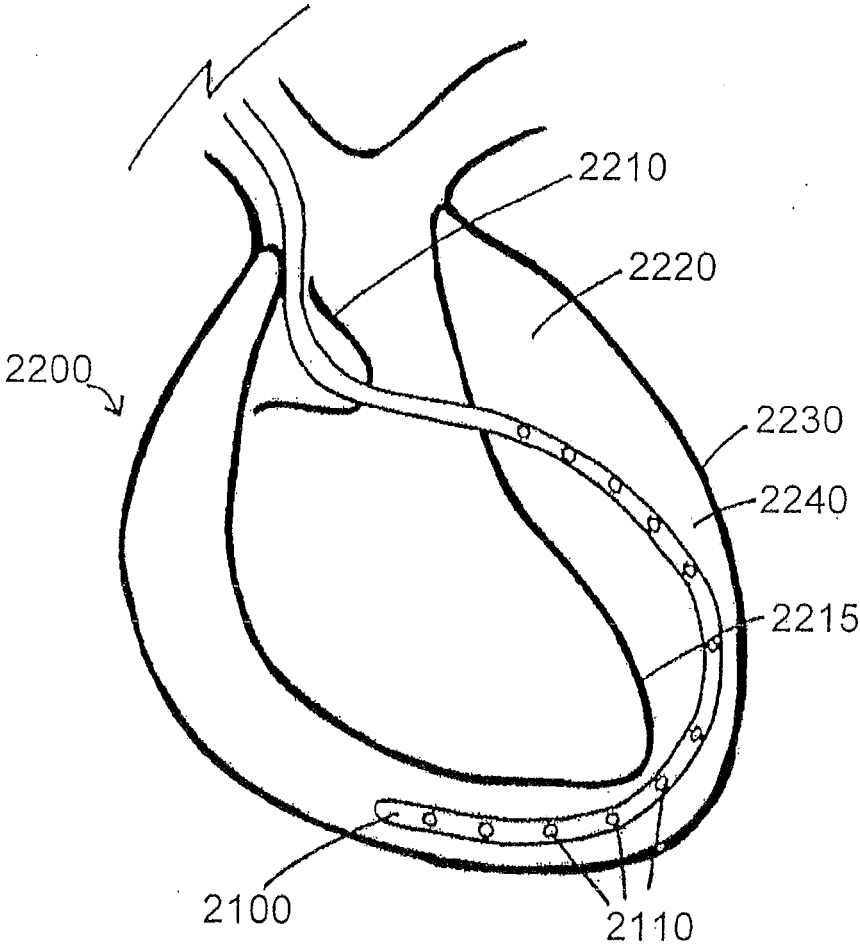
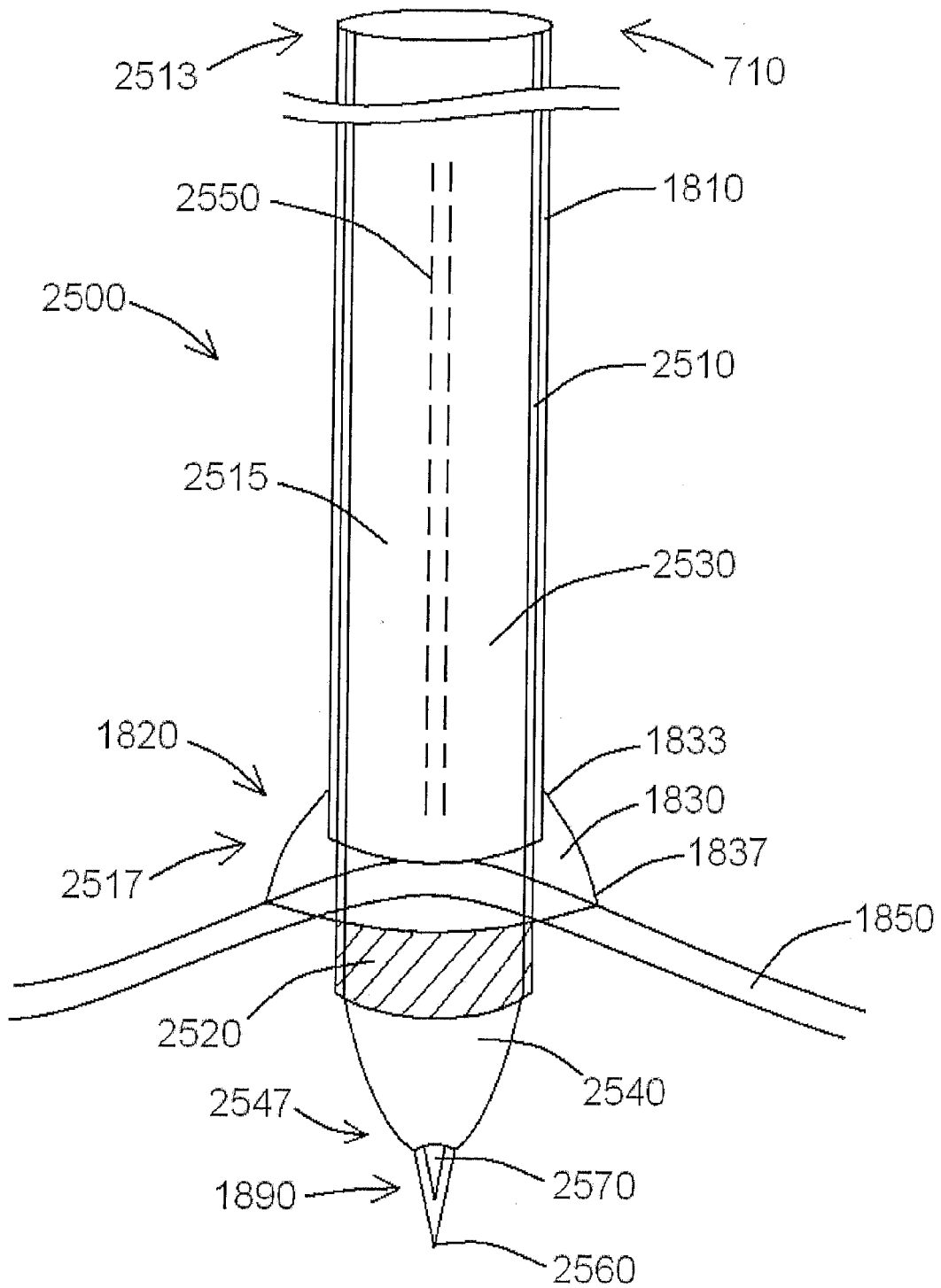
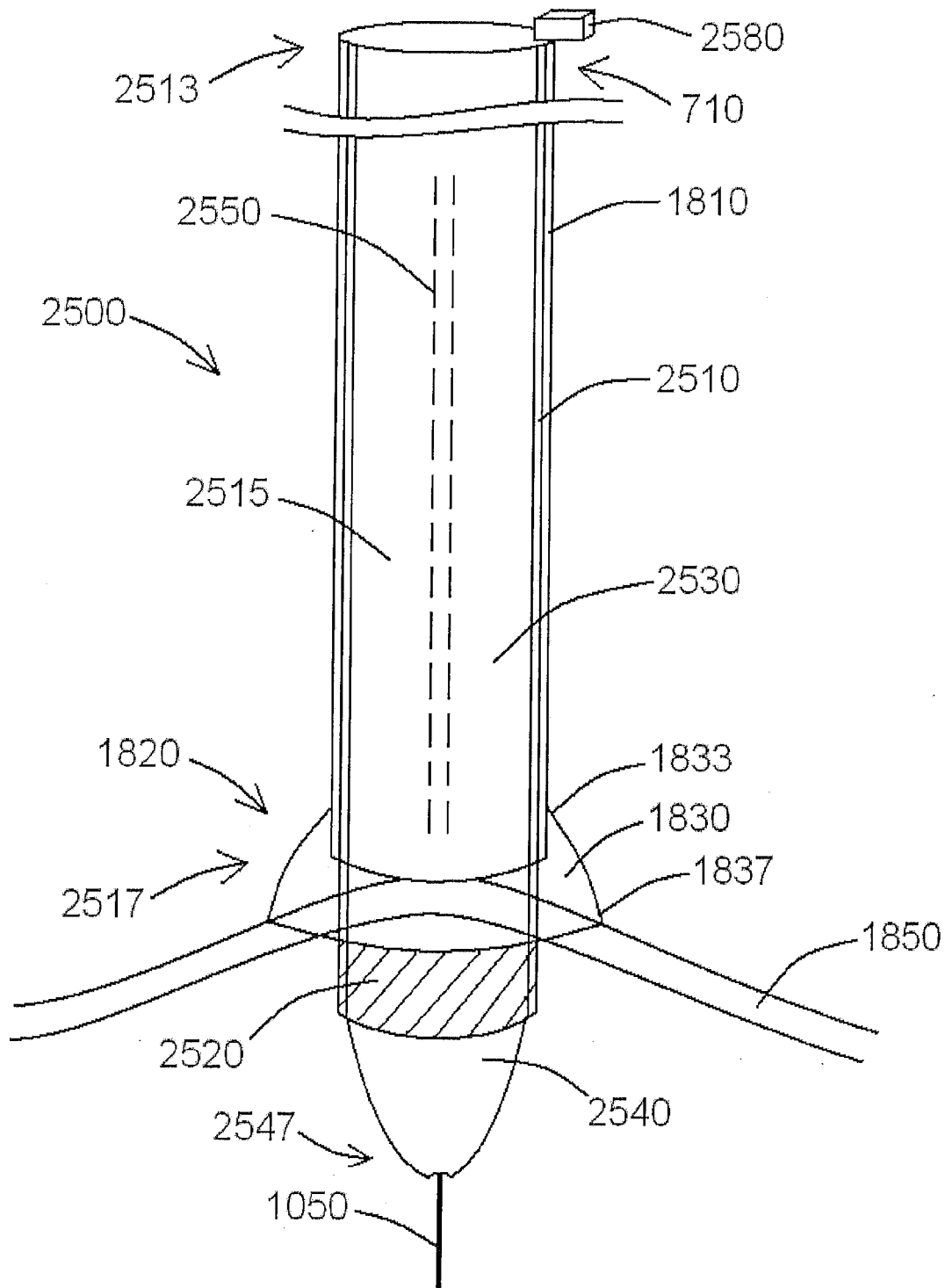

FIG. 22



**Fig. 23**



**Fig. 24**

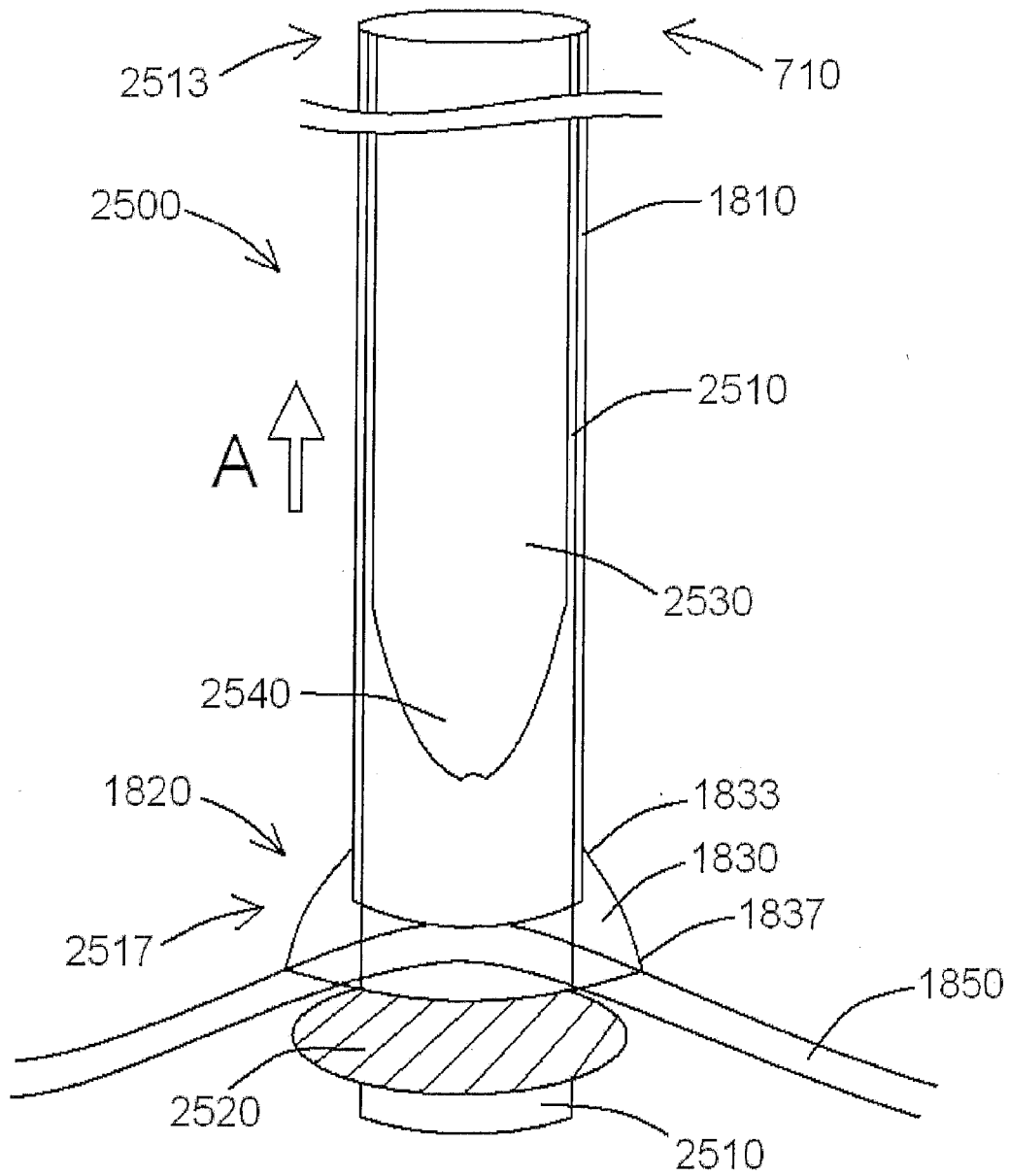

**Fig. 25**

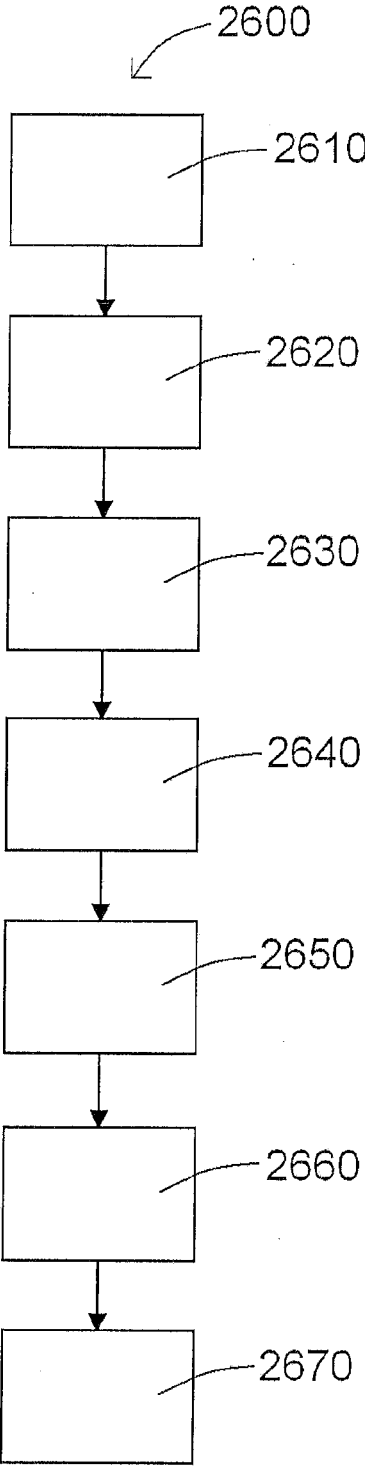

**Fig. 26**

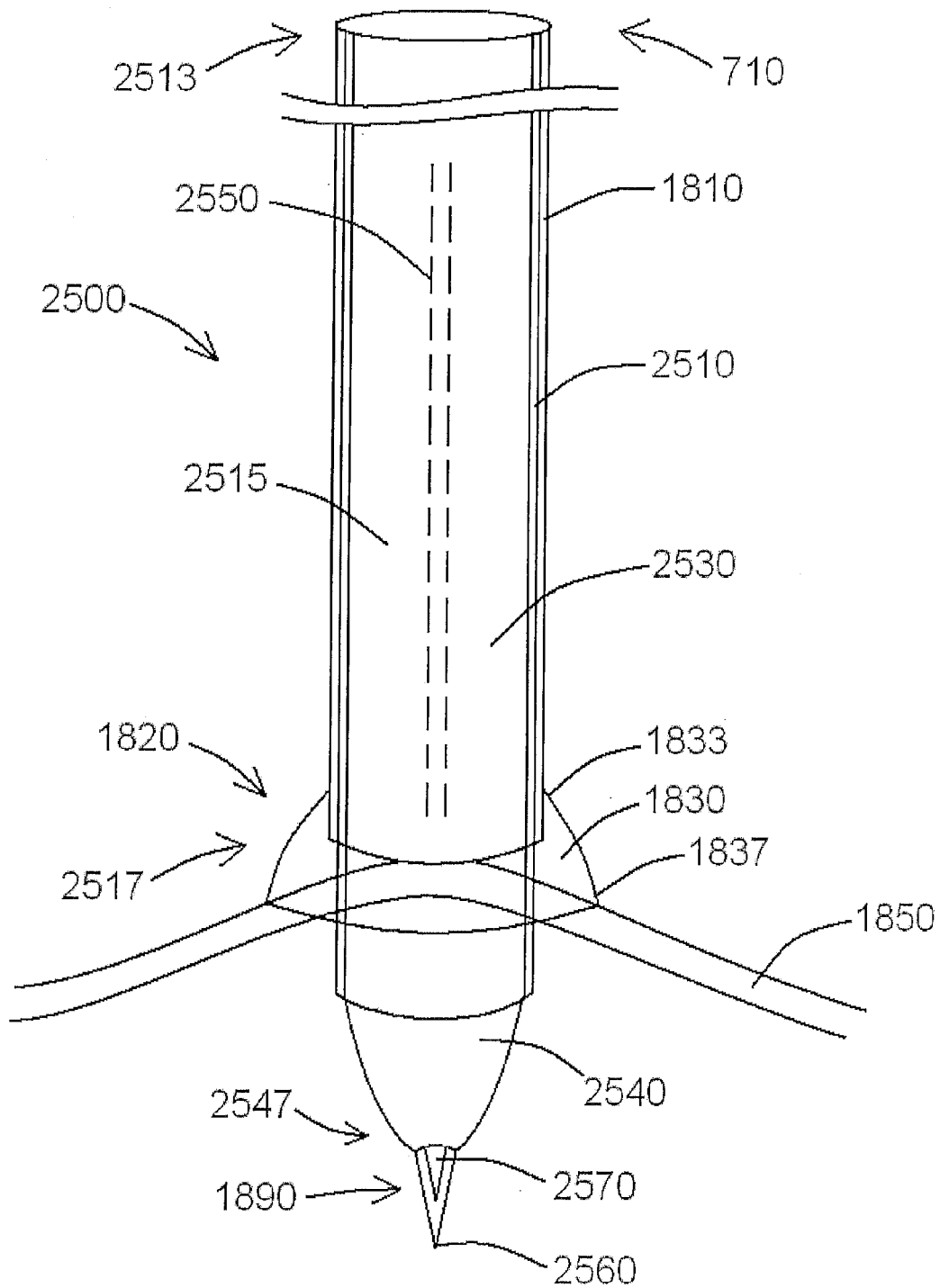

**Fig. 27**

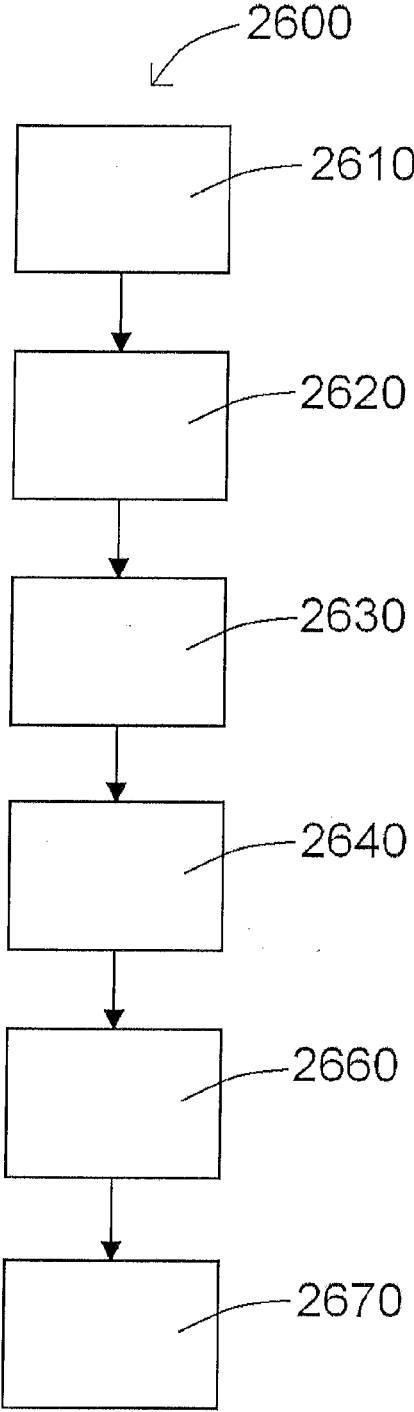

**Fig. 28**

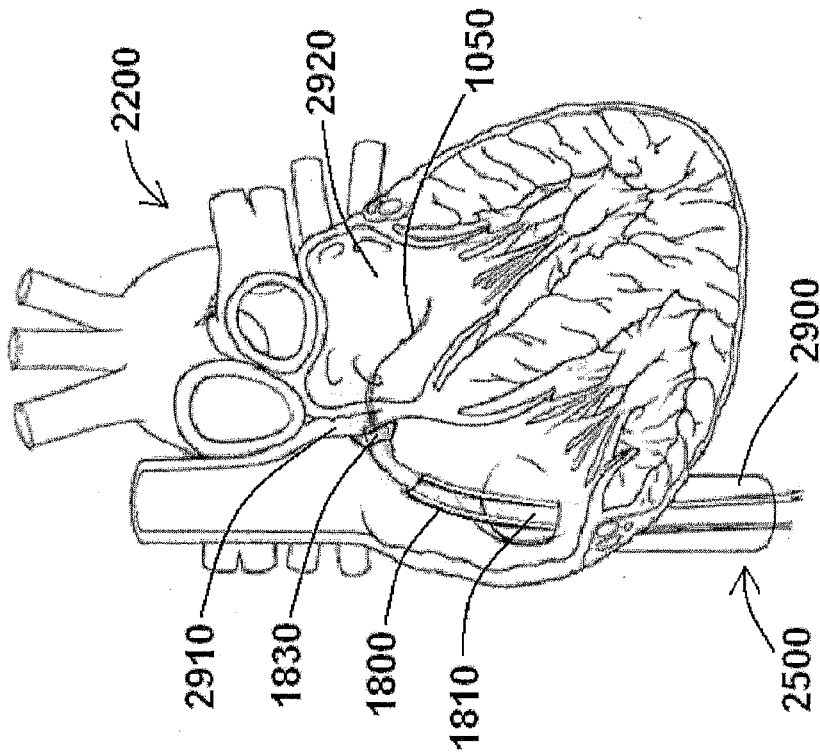

Fig. 29A

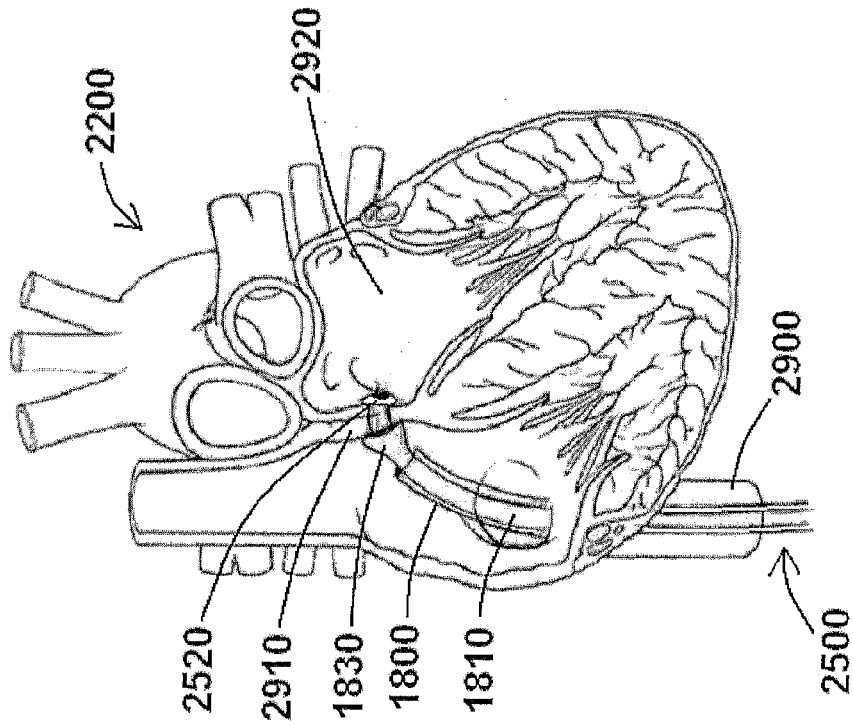

Fig. 29B



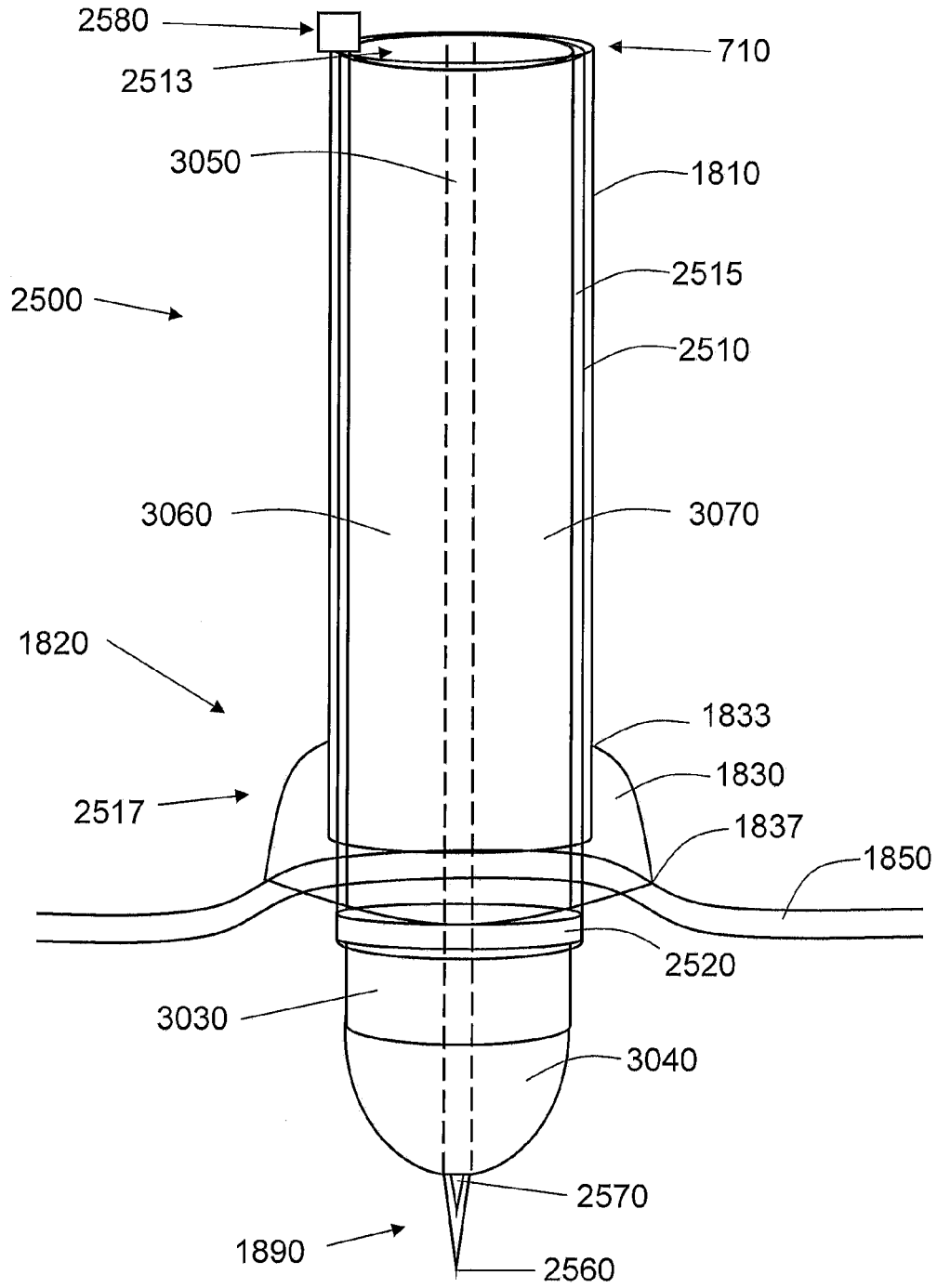

Fig. 30

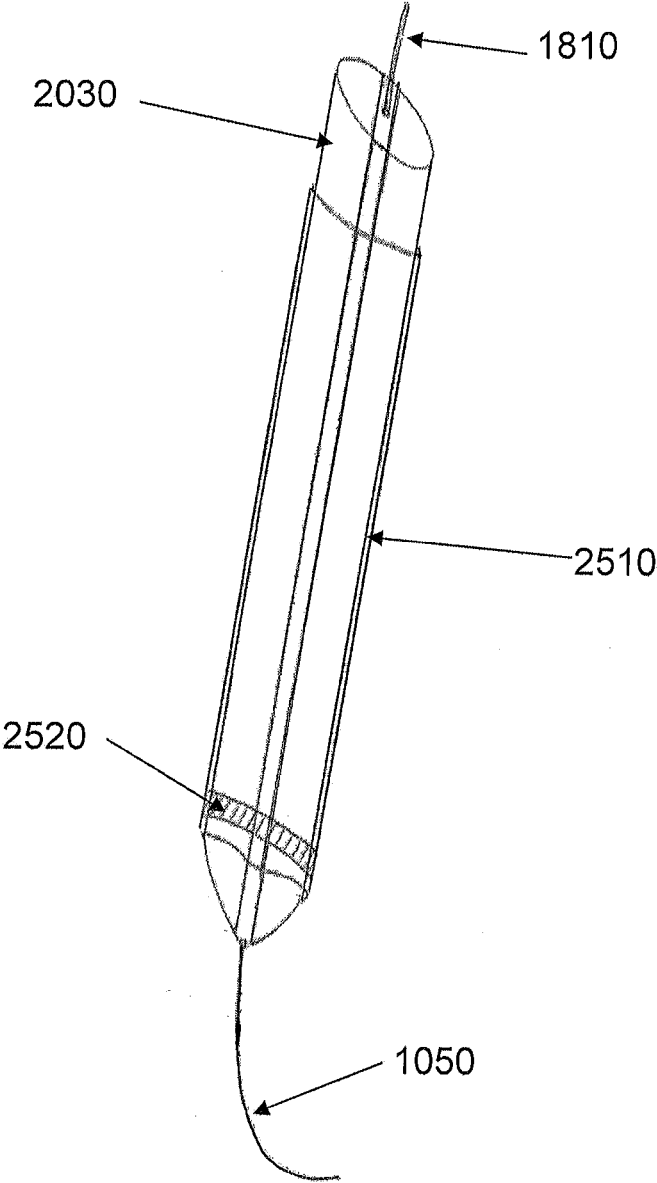

Fig. 31

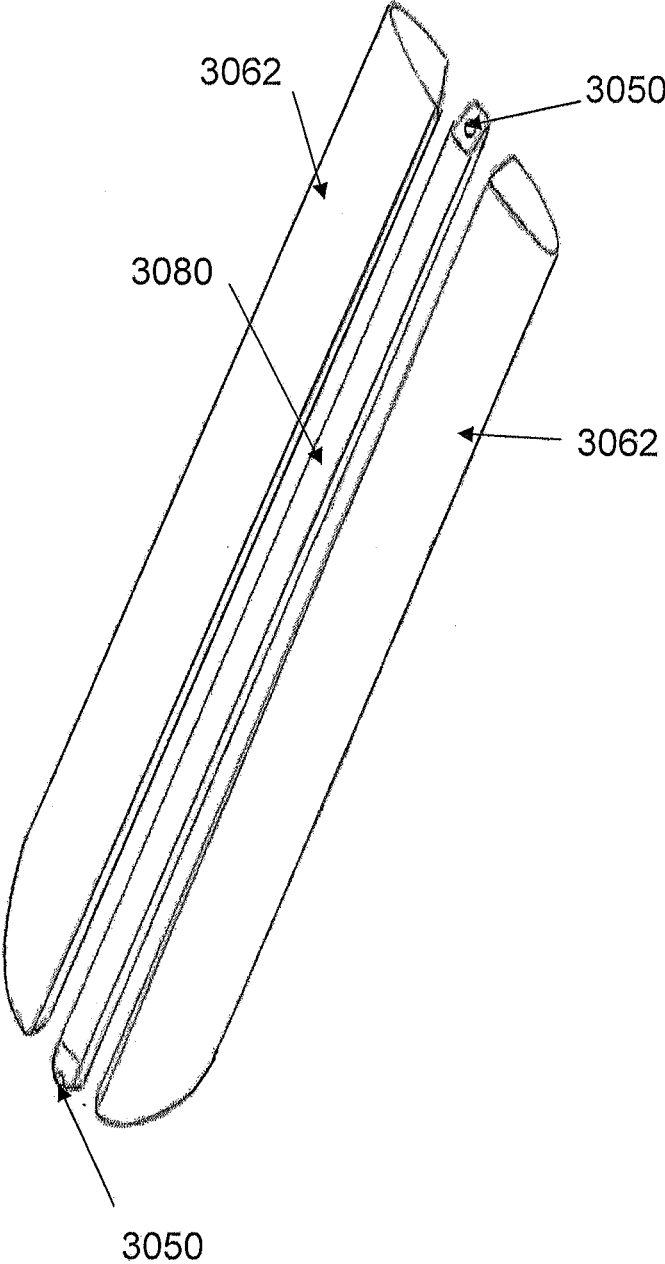

Fig. 32

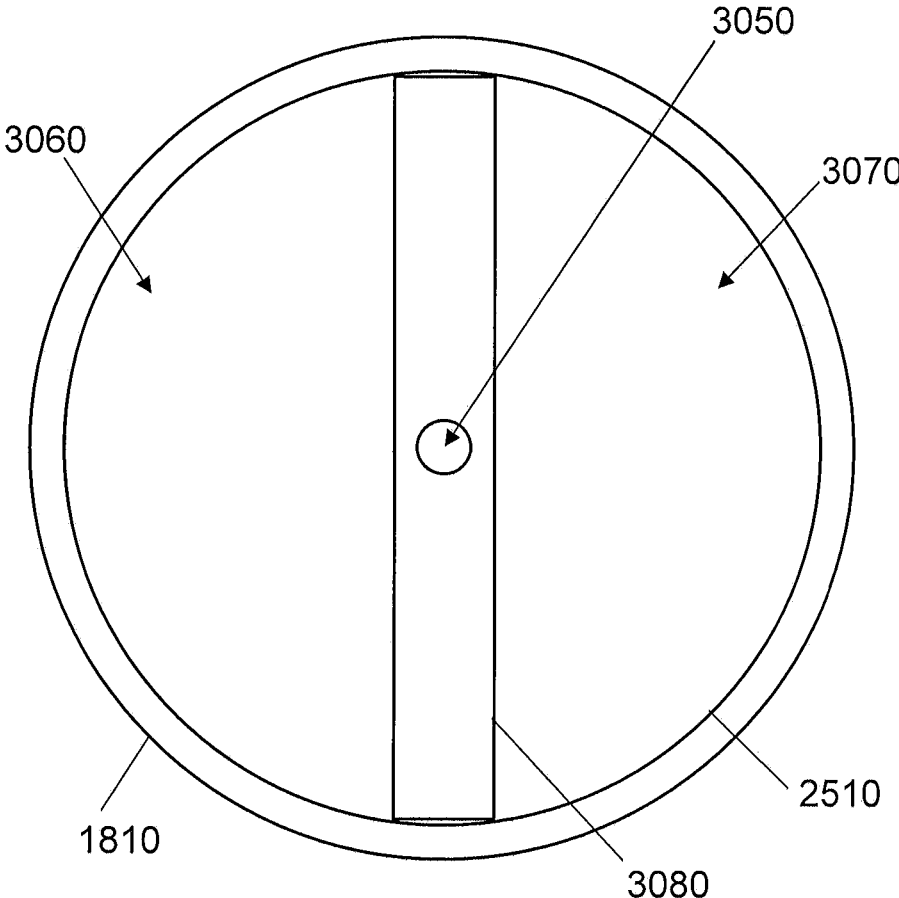

Fig. 33

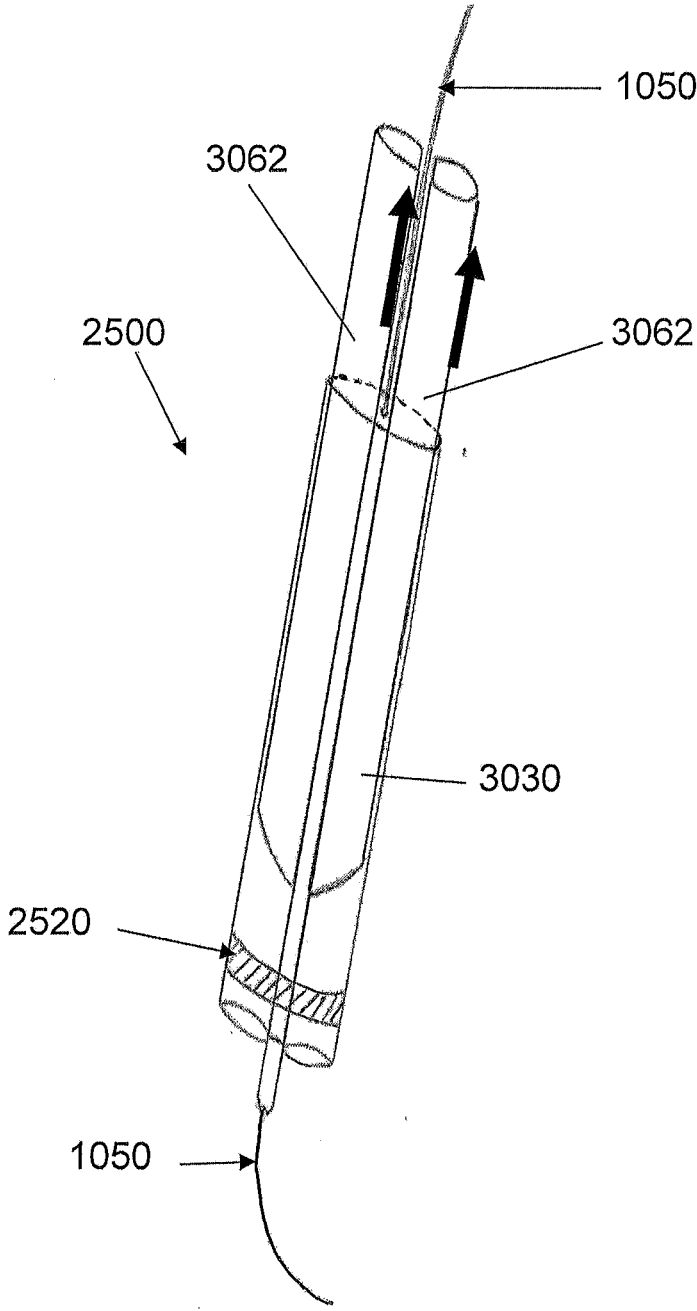

Fig. 34

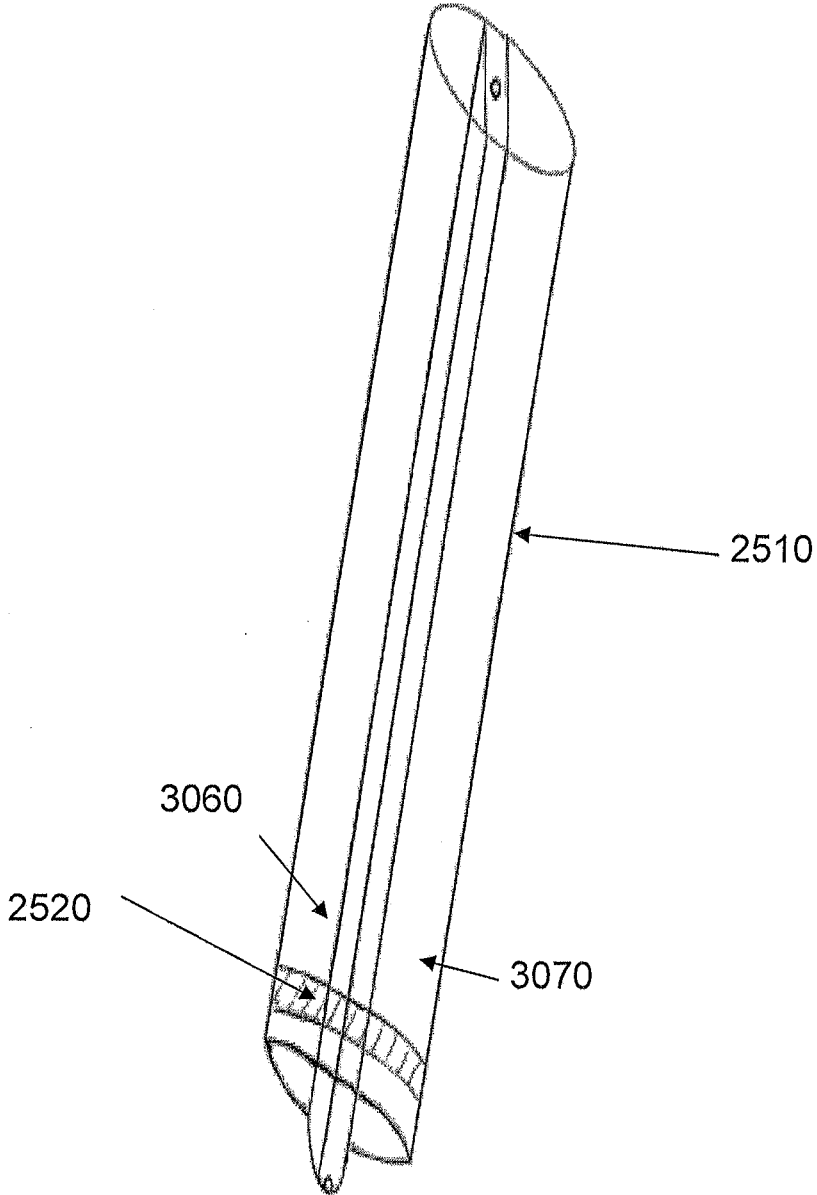

Fig. 35

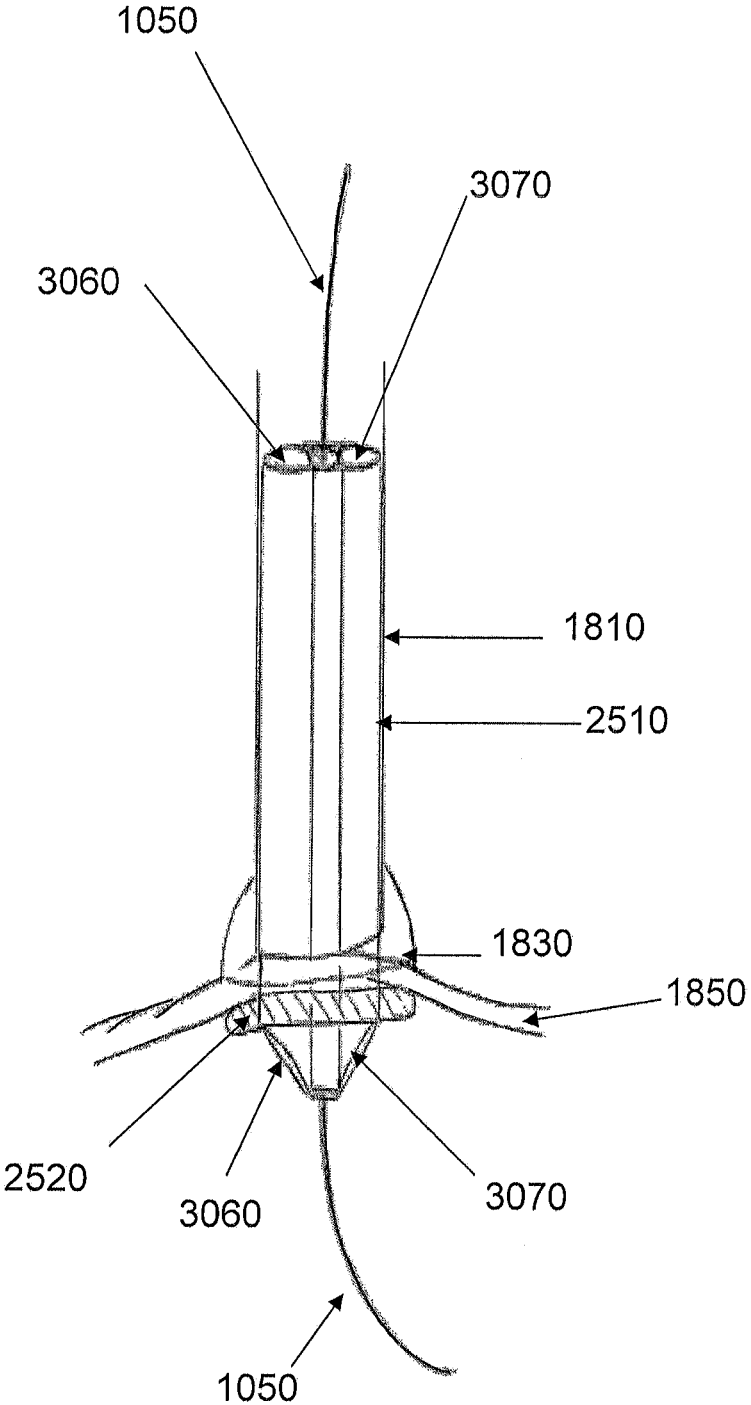

Fig. 36

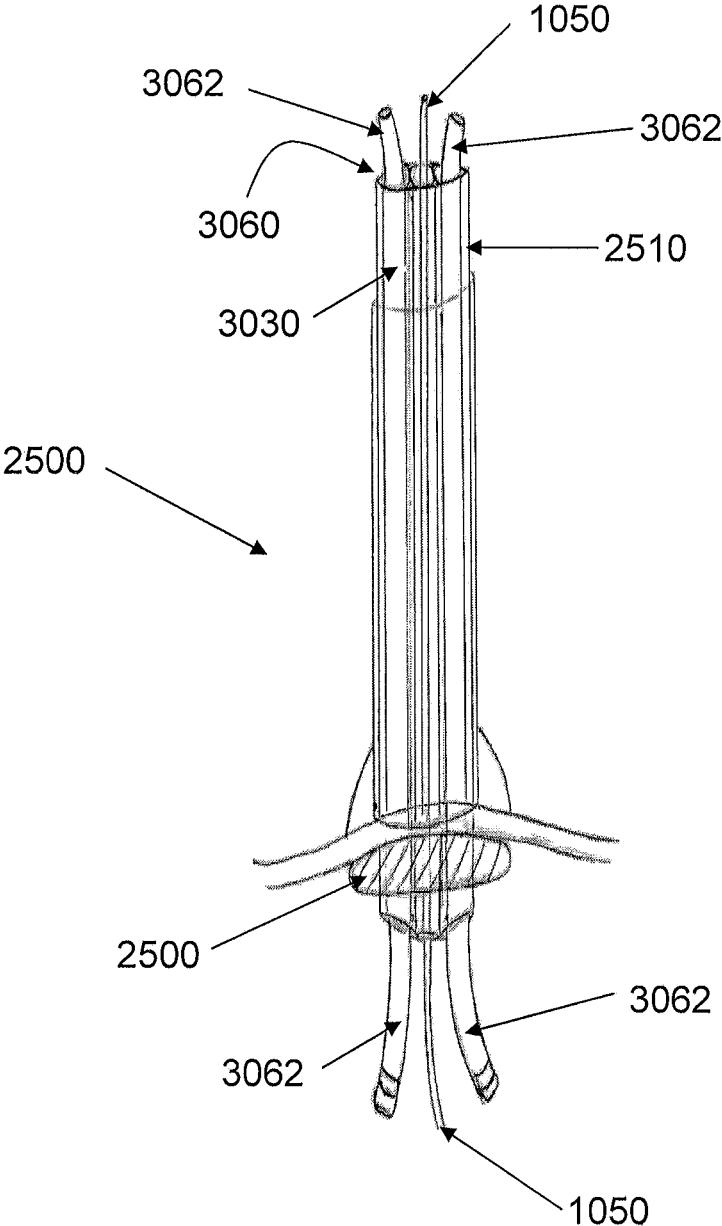

Fig. 37



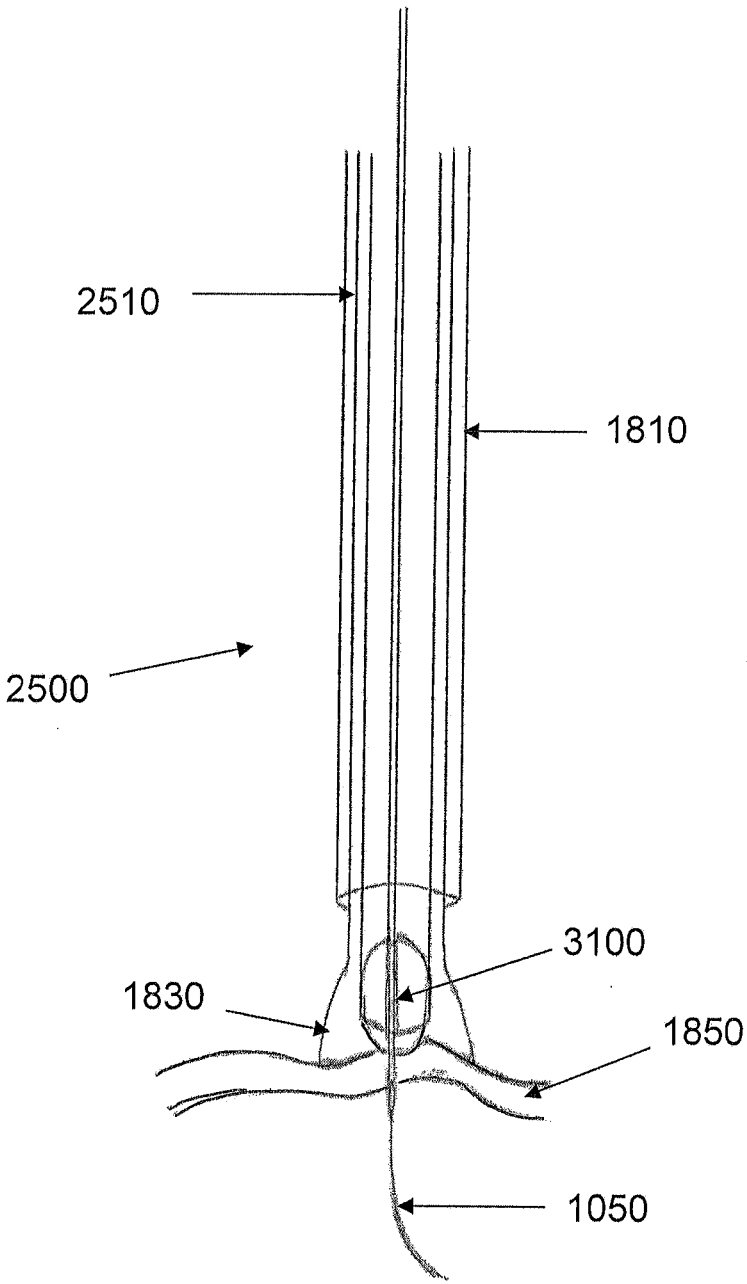

Fig. 38

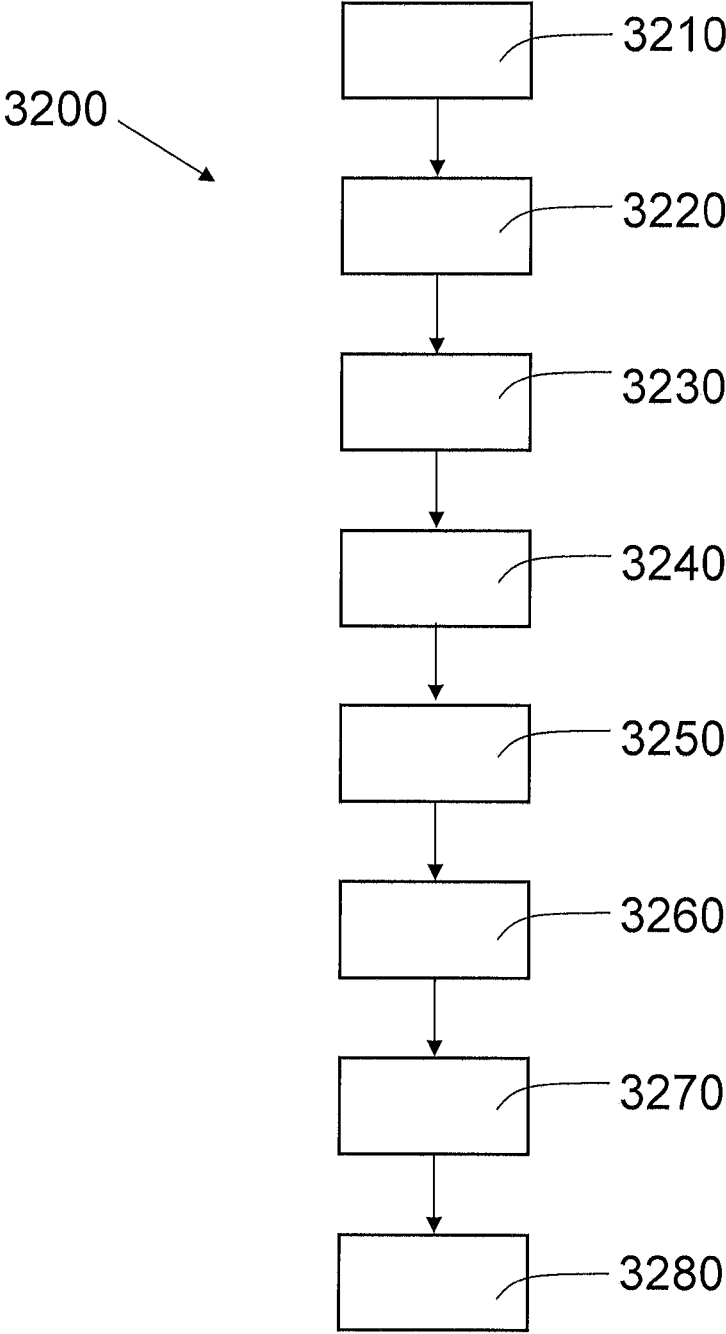

Fig. 39

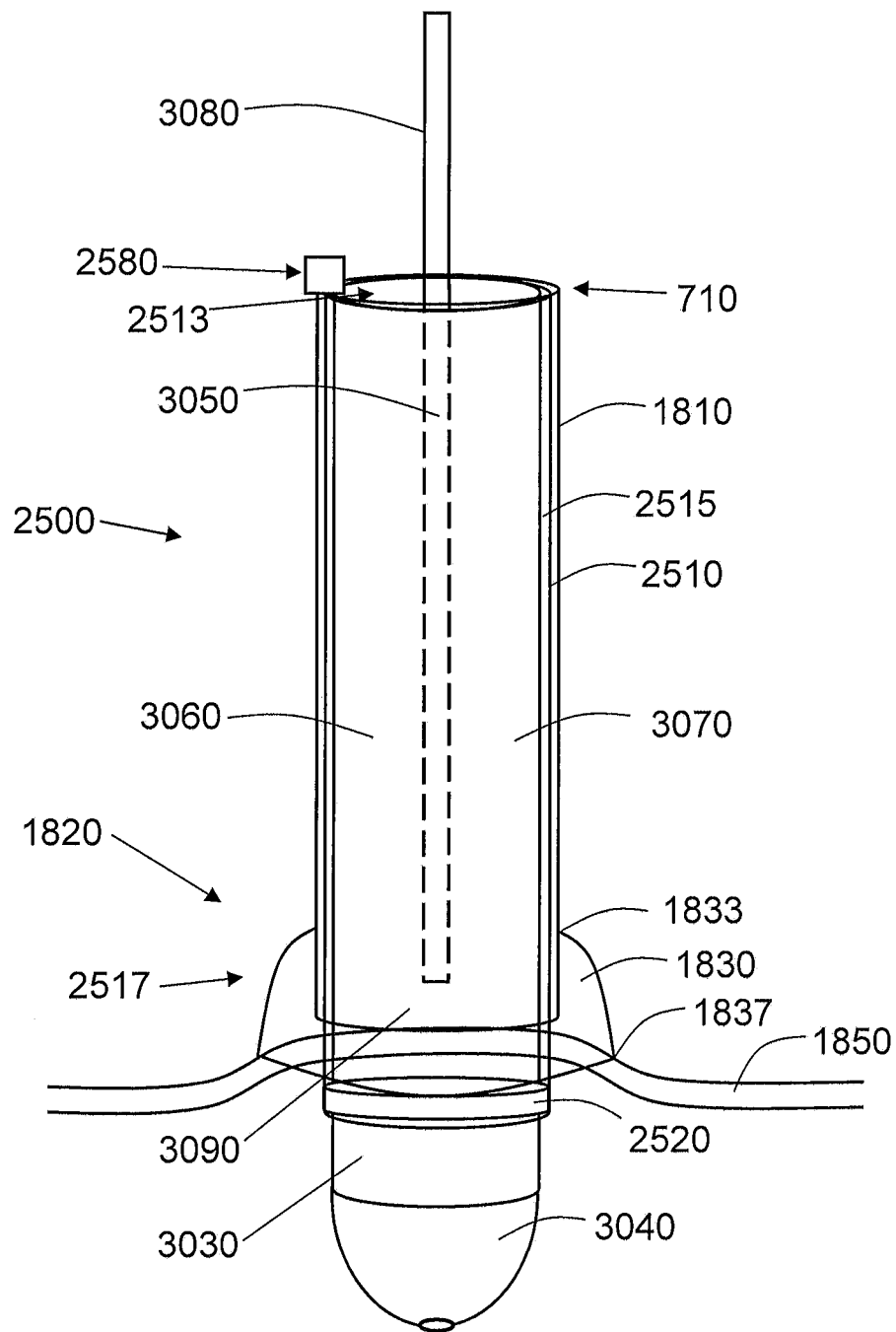

Fig. 40

**SYSTEMS, DEVICES, AND METHODS FOR  
TRANSEPTAL ATRIAL PUNCTURE USING  
AN ENGAGEMENT CATHETER PLATFORM**

**PRIORITY**

**[0001]** This U.S. continuation patent application is related to, and claims the priority benefit of, U.S. nonprovisional patent application Ser. No. 13/084,102, filed Apr. 11, 2011 and issued as U.S. Pat. No. 8,540,674 on Sep. 24, 2013, which is related to, claims the priority benefit of, and is a continuation-in-part of, U.S. nonprovisional patent application Ser. No. 12/881,953, filed Sep. 14, 2010, which is related to, claims the priority benefit of, and is a continuation-in-part of U.S. nonprovisional patent application Ser. No. 12/596,968, filed Oct. 21, 2009, which is related to, claims the priority benefit of, and is a U.S. national stage application of, International Patent Application No. PCT/US2008/056666, filed Mar. 12, 2008, which claims priority to International Patent Application No. PCT/US2008/015207, filed Jun. 29, 2007, and U.S. provisional patent application Ser. No. 60/914,452, filed Apr. 27, 2007. The contents of each of these applications are hereby incorporated by reference in their entirety into this disclosure.

**BACKGROUND**

**[0002]** Ischemic heart disease, or coronary heart disease, kills more Americans per year than any other single cause. In 2004, one in every five deaths in the United States resulted from ischemic heart disease. Indeed, the disease has had a profound impact worldwide. If left untreated, ischemic heart disease can lead to chronic heart failure, which can be defined as a significant decrease in the heart's ability to pump blood. Chronic heart failure is often treated with drug therapy.

**[0003]** Ischemic heart disease is generally characterized by a diminished flow of blood to the myocardium and is also often treated using drug therapy. Although many of the available drugs may be administered systemically, local drug delivery ("LDD") directly to the heart can result in higher local drug concentrations with fewer systemic side effects, thereby leading to improved therapeutic outcomes.

**[0004]** Cardiac drugs may be delivered locally via catheter passing through the blood vessels to the inside of the heart. However, endoluminal drug delivery has several shortcomings, such as: (1) inconsistent delivery, (2) low efficiency of localization, and (3) relatively rapid washout into the circulation.

**[0005]** To overcome such shortcomings, drugs may be delivered directly into the pericardial space, which surrounds the external surface of the heart. The pericardial space is a cavity formed between the heart and the relatively stiff pericardial sac that encases the heart. Although the pericardial space is usually quite small because the pericardial sac and the heart are in such close contact, a catheter may be used to inject a drug into the pericardial space for local administration to the myocardial and coronary tissues. Drug delivery methods that supply the agent to the heart via the pericardial space offer several advantages over endoluminal delivery, including: (1) enhanced consistency and (2) prolonged exposure of the drug to the cardiac tissue.

**[0006]** In current practice, drugs are delivered into the pericardial space either by the percutaneous transventricular method or by the transthoracic approach. The percutaneous transventricular method involves the controlled penetration

of a catheter through the ventricular myocardium to the pericardial space. The transthoracic approach involves accessing the pericardial space from outside the heart using a sheathed needle with a suction tip to grasp the pericardium, pulling it away from the myocardium to enlarge the pericardial space, and injecting the drug into the space with the needle.

**[0007]** For some patients with chronic heart failure, cardiac resynchronization therapy ("CRT") can be used in addition to drug therapy to improve heart function. Such patients generally have an abnormality in conduction that causes the right and left ventricles to beat (i.e., begin systole) at slightly different times, which further decreases the heart's already-limited function. CRT helps to correct this problem of dyssynchrony by resynchronizing the ventricles, thereby leading to improved heart function. The therapy involves the use of an implantable device that helps control the pacing of at least one of the ventricles through the placement of electrical leads onto specified areas of the heart. Small electrical signals are then delivered to the heart through the leads, causing the right and left ventricles to beat simultaneously.

**[0008]** Like the local delivery of drugs to the heart, the placement of CRT leads on the heart can be challenging, particularly when the target placement site is the left ventricle. Leads can be placed using a transvenous approach through the coronary sinus, by surgical placement at the epicardium, or by using an endocardial approach. Problems with these methods of lead placement can include placement at an improper location (including inadvertent placement at or near scar tissue, which does not respond to the electrical signals), dissection or perforation of the coronary sinus or cardiac vein during placement, extended fluoroscopic exposure (and the associated radiation risks) during placement, dislodgement of the lead after placement, and long and unpredictable times required for placement (ranging from about 30 minutes to several hours).

**[0009]** Clinically, the only approved non-surgical means for accessing the pericardial space include the subxiphoid and the ultrasound-guided apical and parasternal needle catheter techniques, and each methods involves a transthoracic approach. In the subxiphoid method, a sheathed needle with a suction tip is advanced from a subxiphoid position into the mediastinum under fluoroscopic guidance. The catheter is positioned onto the anterior outer surface of the pericardial sac, and the suction tip is used to grasp the pericardium and pull it away from the heart tissue, thereby creating additional clearance between the pericardial sac and the heart. The additional clearance tends to decrease the likelihood that the myocardium will be inadvertently punctured when the pericardial sac is pierced.

**[0010]** Although this technique works well in the normal heart, there are major limitations in diseased or dilated hearts—the very hearts for which drug delivery and CRT lead placement are most needed. When the heart is enlarged, the pericardial space is significantly smaller and the risk of puncturing the right ventricle or other cardiac structures is increased. Additionally, because the pericardium is a very stiff membrane, the suction on the pericardium provides little deformation of the pericardium and, therefore, very little clearance of the pericardium from the heart.

**[0011]** As referenced above, the heart is surrounded by a "sac" referred to as the pericardium. The space between the surface of the heart and the pericardium can normally only accommodate a small amount of fluid before the development of cardiac tamponade, defined as an emergency condition in

which fluid accumulates in the pericardium. Therefore, it is not surprising that cardiac perforation can quickly result in tamponade, which can be lethal. With a gradually accumulating effusion, however, as is often the case in a number of diseases, very large effusions can be accommodated without tamponade. The key factor is that once the total intrapericardial volume has caused the pericardium to reach the noncompliant region of its pressure-volume relation, tamponade rapidly develops. Little W. C., Freeman G. L. (2006). "Pericardial Disease." *Circulation* 113(12): 1622-1632.

**[0012]** Cardiac tamponade occurs when fluid accumulation in the intrapericardial space is sufficient to raise the pressure surrounding the heart to the point where cardiac filling is affected. Ultimately, compression of the heart by a pressurized pericardial effusion results in markedly elevated venous pressures and impaired cardiac output producing shock which, if untreated, it can be rapidly fatal. Id.

**[0013]** The frequency of the different causes of pericardial effusion varies depending in part upon geography and the patient population, Corey G. R. (2007). "Diagnosis and treatment of pericardial effusion." <http://patients.uptodate.com>. A higher incidence of pericardial effusion is associated with certain diseases. For example, twenty-one percent of cancer patients have metastases to the pericardium. The most common are lung (37% of malignant effusions), breast (22%), and leukemia/lymphoma (17%). Patients with HIV, with or without AIDS, are found to have increased prevalence, with 41-87% having asymptomatic effusion and 13% having moderate-to-severe effusion. Strimel W. J. e. a. (2006). "Pericardial Effusion." <http://www.emedicine.com/med/topic1786.htm>.

**[0014]** End-stage renal disease is a major public health problem. In the United States, more than 350,000 patients are being treated with either hemodialysis or continuous ambulatory peritoneal dialysis. Venkat A., Kaufmann K. R., Venkat K. (2006). "Care of the end-stage renal disease patient on dialysis in the ED." *Am J Emerg Med* 24(7): 847-58. Renal failure is a common cause of pericardial disease, producing large pericardial effusions in up to 20% of patients. Task Force members, Maisch B. et al. (2004), "Guidelines on the Diagnosis and Management of Pericardial Diseases Executive Summary: The Task Force on the Diagnosis and Management of Pericardial Diseases of the European Society of Cardiology," *Eur Heart J* 25(7): 587-610.

**[0015]** Viral pericarditis is the most common infection of the pericardium, Inflammatory abnormalities are due to direct viral attack, the immune response (antiviral or anticardiac), or both. Id. Purulent (bacterial) pericarditis in adults is rare, but always fatal if untreated. Mortality rate in treated patients is 40%, mostly due to cardiac tamponade, toxicity, and constriction. It is usually a complication of an infection originating elsewhere in the body, arising by contiguous spread or haematogenous dissemination. Id. Other forms of pericarditis include tuberculous and neoplastic.

**[0016]** The most common secondary malignant tumors are lung cancer, breast cancer, malignant melanoma, lymphomas, and leukemias. Effusions may be small or large with an imminent tamponade. In almost two-thirds of the patients with documented malignancy pericardial effusion is caused by non-malignant diseases, e.g., radiation pericarditis, or opportunistic infections. The analyses of pericardial fluid, pericardial or epicardial biopsy are essential for the confirmation of malignant pericardial disease. Id.

**[0017]** Management of pericardial effusions continues to be a challenge. There is no uniform consensus regarding the best way to treat this difficult clinical entity. Approximately half the patients with pericardial effusions present with symptoms of cardiac tamponade. In these cases, symptoms are relieved by pericardial decompression, irrespective of the underlying cause. Georghiou G. P., Stamler A., Sharoni E., Fichman-Horn S., Berman M., Vidne B. A., Saute M. (2005). "Video-Assisted Thoracoscopic Pericardial Window for Diagnosis and Management of Pericardial Effusions." *Ann Thorac Surg* 80(2): 607-610. Symptomatic pericardial effusions are common and may result from a variety of causes. When medical treatment has failed to control the effusion or a diagnosis is needed, surgical intervention is required. Id.

**[0018]** The most effective management of pericardial effusions has yet to be identified. The conventional procedure is a surgically placed pericardial window under general anesthesia. This procedure portends significant operative and anesthetic risks because these patients often have multiple comorbidities. Less invasive techniques such as blind needle pericardiocentesis have high complication and recurrence rates. The technique of echocardiographic-guided pericardiocentesis with extended catheter drainage is performed under local anesthetic with intravenous sedation. Creating a pericardiostomy with a catheter in place allows for extended drainage and sclerotherapy. Echocardiographic-guided pericardiocentesis has been shown to be a safe and successful procedure when performed at university-affiliated or academic institutions. However, practices in community hospitals have rarely been studied in detail, Buchanan C. L., Sullivan V. V., Lampman R., Kulkarni M. G. (2003). "Pericardiocentesis with extended catheter drainage: an effective therapy." *Ann Thorac Surg* 76(3): 817-82.

**[0019]** The treatment of cardiac tamponade is drainage of the pericardial effusion. Medical management is usually ineffective and should be used only while arrangements are made for pericardial drainage. Fluid resuscitation may be of transient benefit if the patient is volume depleted (hypovolemic cardiac tamponade).

**[0020]** Surgical drainage (or pericardiectomy) is excessive for many patients. The best option is pericardiocentesis with the Seldinger technique, leaving a pigtail drainage catheter that should be kept in place until drainage is complete. Sagrista Saulea J., Permanyer Miralda G., Soler Soler J. (2005). "[Diagnosis and management of acute pericardial syndromes]." *Rev Esp Cardiol* 58(7): 830-41. This less-invasive technique resulted in a short operative time and decreased supply, surgeon, and anesthetic costs. When comparing procedure costs of a pericardial window versus an echo-guided pericardiocentesis with catheter drainage at our institution, there was a cost savings of approximately \$1,800/case in favor of catheter drainage. In an era of accelerating medical costs, these savings are of considerable importance. Buchanan C. L., Sullivan V. V., Lampman R., Kulkarni M. G. (2003). "Pericardiocentesis with extended catheter drainage: an effective therapy." *Ann Thorac Surg* 76(3): 817-82.

**[0021]** Clearly, there is a clinical need for a mini-invasive, safe and effective approach to treatment of pericardial effusion and tamponade. The present application takes advantage of a safe and effective pericardial access approach previously disclosed in combination with a special catheter used specifically for fluid drainage, fluid diagnosis, resuscitation and therapy delivery to treat the underlying cause of the effusion.

[0022] Thus, there is need for an efficient, easy to use, and relatively inexpensive device, system and technique that can be used to access the heart for local delivery of therapeutic and diagnostic substances, as well as of CRT leads and other types of leads. There is also a need for an efficient, easy to use, and relatively inexpensive device, system and technique that can be used to access a space containing fluid within a tissue to remove the fluid and to optionally deliver a substance if necessary.

#### BRIEF SUMMARY

[0023] Disclosed herein are various systems for engaging a bodily tissue and methods of using the same, including, but not limited to, systems and methods for accessing the internal and external tissues of the heart. At least some of the disclosed embodiments provide access to the external surface of the heart through the pericardial space for localized delivery of leads to the heart tissue.

[0024] In at least one embodiment of a multichannel system for engaging a tissue, the system comprises an engagement catheter comprising a proximal end and a distal end, and defining a first lumen extending between the proximal end and the distal end, an inducer sheath having a proximal portion and a distal portion, and defining a lumen extending therethrough, the inducer sheath configured for insertion into the second lumen of the engagement catheter, and a dilator defining a first channel and a second channel extending therethrough and a tapered tip at the distal end of the dilator, the dilator sized and shaped for insertion into the lumen of the inducer sheath. According to an embodiment, the system may further comprise a needle device having a needle tip, the needle device capable of insertion into the first channel of the dilator, wherein the needle tip is capable of puncturing a tissue positioned at or near the distal end of the dilator. Additionally, in another embodiment of the system, the second channel is sized and shaped to allow passage of at least a portion of a first catheter therethrough. In another embodiment of the system, the dilator further defines a third channel extending therethrough, the third channel sized and shaped to allow passage of at least a portion of a second catheter therethrough.

[0025] In at least one embodiment of a multichannel system for engaging a tissue, the dilator further defines a separation member extending therethrough and separating the first channel, second channel and third channel of the dilator. The separation member in at least one embodiment is removable from the dilator, and upon removal merges the first channel, second channel and third channel into a central channel. In another embodiment, the system further comprises a blocking member configured for insertion into the second channel of the dilator to occlude the second channel of the dilator. In another embodiment, the system comprises a visualization device configured for insertion into the first channel of the dilator, wherein the visualization device is operable to gather location information. In another embodiment, the visualization device of at least one embodiment of the system is selected from the group consisting of an endocardial visualization device, an endoscope, and a catheter.

[0026] In at least one embodiment of a multichannel system for engaging a tissue, the engagement catheter further defines a second lumen and further comprises a skirt operatively connected to the distal end of the engagement catheter, the skirt comprising a proximal end having a circumference substantially similar to an outer circumference of the engage-

ment catheter, the skirt further comprising a distal end having a circumference larger than the outer circumference of the engagement catheter. In another embodiment the system further comprises a vacuum port located at the proximal end of the engagement catheter, the vacuum port operably connected to the second lumen of the engagement catheter and capable of operative connection to a vacuum source, and wherein the second lumen of the engagement catheter includes a suction port located at or near the distal end of the engagement catheter, the suction port configured to allow the distal end of the skirt to removably engage a surface of a bodily tissue such that the skirt is capable of forming a reversible seal with the surface of the tissue when a vacuum source is operatively attached to the vacuum port. In another embodiment, the system further comprises a guide wire configured for insertion into the first channel of the dilator. In yet another embodiment, the needle defines a needle lumen therethrough, the needle lumen sized and shaped to receive the guide wire therethrough. In at least one embodiment of the system, the system further comprises an inflatable balloon at or near the distal portion of the inducer sheath. The balloon may in at least one embodiment be comprised of a radiopaque material, such as a polyamide elastomer and tungsten.

[0027] In at least one embodiment of a multichannel system for engaging a tissue, the inducer sheath is comprised of Teflon. Further, in at least one embodiment, the inducer sheath has a wall thickness from about 0.2 mm to about 0.3 mm. Moreover, the inducer sheath, in at least one embodiment, has a length of within about 5 mm to about 6 mm of a length of the engagement catheter. The proximal portion of the inducer sheath, in another embodiment, is affixed to the proximal end of the engagement catheter.

[0028] In at least one embodiment of a multichannel system for engaging a tissue, the tapered tip of the dilator has a conical shape. In another embodiment, dilator is comprised of polyethylene. Further, in another embodiment, the tapered tip is comprised of polyurethane. In yet another embodiment, the dilator further comprises a dilator lock capable of preventing the dilator from backward movement after the dilator is inserted into the lumen of the inducer sheath and the dilator lock is locked. In at least one embodiment of the system, the skirt comprises a deformable configuration, and wherein the deformable configuration of the skirt is capable of expanding to an expanded configuration.

[0029] In at least one embodiment of a multichannel system for engaging a tissue, the system comprises an engagement catheter comprising a proximal end, a distal end, first and second lumens extending between the proximal end and the distal end, and a skirt operatively connected to the distal end, the skirt comprising a proximal end having a circumference substantially similar to an outer circumference of the engagement catheter, the skirt further comprising a distal end having a circumference larger than the outer circumference of the engagement catheter, an inducer sheath having a proximal portion, a distal portion, a lumen extending therethrough, and a radiopaque inflatable balloon at or near the distal portion of the inducer sheath, the inducer sheath configured so that it is capable of insertion into the first lumen of the engagement catheter, a dilator comprising a first and second channel extending therethrough and a tapered tip at the distal end of the dilator, the dilator sized and shaped for insertion into the lumen of the inducer sheath, a vacuum port located at the proximal end of the engagement catheter, the vacuum port being operatively connected to the first lumen of the engage-

ment catheter and capable of operative connection to a vacuum source, and a visualization device capable of insertion into the first channel of the dilator, wherein the visualization device is capable of gathering location information, wherein the first lumen of the engagement catheter includes a suction port located at or near the distal end of the engagement catheter, the suction port configured to allow the distal end of the skirt to removably engage an atrial wall when the atrial wall is adjacent thereto, such that the skirt is capable of forming a reversible seal with the surface of the atrial wall when a vacuum source is operatively attached to the vacuum port.

**[0030]** In at least one embodiment of a method of engaging a tissue to access a space adjacent thereto, the method comprises the steps of introducing a multichannel system into a mammalian body so that at least part of the system is adjacent to a targeted tissue, the system comprising an engagement catheter having a skirt coupled thereto, an inducer sheath positioned within a lumen of the engagement catheter, a dilator positioned within a lumen of the inducer sheath, a needle positioned within a first channel of the dilator, and a catheter positioned within a second channel of the dilator. An embodiment of the method, further comprises the steps of engaging the targeted tissue using the skirt of the engagement catheter by applying a vacuum to the engagement catheter, piercing the targeted tissue using the needle to create a tissue aperture; advancing at least part of the inducer sheath and at least part of the dilator into the tissue aperture and into a space behind the targeted tissue, and inserting at least a portion of the catheter into the space behind the targeted tissue. In another embodiment of the method, the step of advancing causes a balloon coupled to the inducer sheath to be positioned into the space behind the targeted tissue, and wherein the method further comprises the step of inflating the balloon to reversibly secure the inducer sheath to the targeted tissue. In yet another embodiment of the method, the advancing step further comprises the withdrawal of the needle from at least part of the lumen of the dilator. In another embodiment of the method, the method further comprises the steps of removing the dilator from the inducer sheath, and performing a procedure, the procedure selected from the group consisting of introducing a substance into the space, removing a substance from the space, and introducing a device into the space. The step of engaging the targeted tissue, in at least one embodiment, comprises the step of engaging an atrial wall, and wherein the step of advancing comprises the step of advancing at least part of the inducer sheath and the dilator into and through an atrial wall aperture. Moreover, the step of engaging the targeted tissue, in at least one embodiment, comprises the step of engaging an atrial septum, and wherein the step of advancing comprises the step of advancing at least part of the inducer sheath and the dilator into an atrial septum aperture and into a left atrium.

#### BRIEF DESCRIPTION OF THE DRAWINGS

**[0031]** FIG. 1A shows an embodiment of an engagement catheter and an embodiment of a delivery catheter as disclosed herein;

**[0032]** FIG. 1B shows a percutaneous intravascular pericardial delivery using another embodiment of an engagement catheter and another embodiment of a delivery catheter as disclosed herein;

**[0033]** FIG. 2A shows a percutaneous intravascular technique for accessing the pericardial space through a right atrial wall or atrial appendage using the engagement and delivery catheters shown in FIG. 1A;

**[0034]** FIG. 2B shows the embodiment of an engagement catheter shown in FIG. 2A;

**[0035]** FIG. 2C shows another view of the distal end of the engagement catheter embodiment shown in FIGS. 2A and 2B;

**[0036]** FIG. 3A shows removal of an embodiment of a catheter as disclosed herein;

**[0037]** FIG. 3B shows the resealing of a puncture according to an embodiment as disclosed herein;

**[0038]** FIGS. 4A to 4C show a closure of a hole in the atrial wall using an embodiment as disclosed herein;

**[0039]** FIG. 4D shows another closure of a hole in cardiac tissue using another embodiment as disclosed herein;

**[0040]** FIG. 4E shows yet another closure of a hole in cardiac tissue using another embodiment as disclosed herein;

**[0041]** FIG. 4F shows still another closure of a hole in cardiac tissue using another embodiment as disclosed herein;

**[0042]** FIG. 5A shows an embodiment of an engagement catheter as disclosed herein;

**[0043]** FIG. 5B shows a cross-sectional view of the proximal end of the engagement catheter shown in FIG. 5A;

**[0044]** FIG. 5C shows a cross-sectional view of the distal end of the engagement catheter shown in FIG. 5A;

**[0045]** FIG. 5D shows the engagement catheter shown in FIG. 5A approaching a heart wall from inside of the heart;

**[0046]** FIG. 6A shows an embodiment of a delivery catheter as disclosed herein;

**[0047]** FIG. 6B shows a close-up view of the needle shown in FIG. 6A;

**[0048]** FIG. 6C shows a cross-sectional view of the needle shown in FIGS. 6A and 6B;

**[0049]** FIG. 7 shows an embodiment of a delivery catheter as disclosed herein;

**[0050]** FIG. 8 shows an embodiment of a steering wire system within a steering channel;

**[0051]** FIG. 9A shows another embodiment of a steering wire system as disclosed herein, the embodiment being deflected in one location;

**[0052]** FIG. 9B shows the steering wire system shown in FIG. 9A, wherein the steering wire system is deflected at two locations;

**[0053]** FIG. 9C shows the steering wire system shown in FIGS. 9A and 9B in its original position;

**[0054]** FIG. 10 shows a portion of another embodiment of a steering wire system;

**[0055]** FIG. 11 shows a cross-sectional view of another embodiment of a delivery catheter as disclosed herein;

**[0056]** FIG. 12A shows an embodiment of a system for closing a hole in cardiac tissue, as disclosed herein;

**[0057]** FIG. 12B shows another embodiment of a system for closing a hole in cardiac tissue, as disclosed herein;

**[0058]** FIG. 12C shows another embodiment of a system for closing a hole in cardiac tissue, as disclosed herein;

**[0059]** FIG. 13 shows another embodiment of a system for closing a hole in cardiac tissue, as disclosed herein;

**[0060]** FIG. 14 shows another embodiment of a system for closing a hole in cardiac tissue, as disclosed herein;

**[0061]** FIG. 15A shows another embodiment of a system for closing a hole in cardiac tissue, as disclosed herein;

[0062] FIG. 15B shows the embodiment of FIG. 15A approaching cardiac tissue;

[0063] FIG. 15C shows the embodiment of FIGS. 15A-15C deployed on the cardiac tissue;

[0064] FIG. 16A shows an embodiment of a portion of an apparatus for engaging a tissue having a skirt positioned substantially within a sleeve, as disclosed herein;

[0065] FIG. 16B shows another embodiment of a portion of an apparatus for engaging a tissue, as disclosed herein;

[0066] FIG. 16C shows an embodiment of a portion of an apparatus for engaging a tissue having a skirt positioned substantially outside of a sleeve, as disclosed herein;

[0067] FIG. 17A shows an embodiment of a portion of an apparatus for engaging a tissue that has engaged a tissue, as disclosed herein;

[0068] FIG. 17B shows an embodiment of a portion of an apparatus for engaging a tissue having an expanded skirt that has engaged a tissue, as disclosed herein;

[0069] FIG. 18A shows an embodiment of a portion of an apparatus for engaging a tissue having a collapsed skirt present within a sleeve, as disclosed herein;

[0070] FIG. 18B shows an embodiment of a portion of an apparatus for engaging a tissue having an expanded skirt, as disclosed herein;

[0071] FIG. 19 shows an embodiment of a system for engaging a tissue, as disclosed herein;

[0072] FIG. 20A shows an embodiment of a portion of an apparatus for engaging a tissue having a lead positioned therethrough, as disclosed herein;

[0073] FIG. 20B shows an embodiment of a portion of an apparatus for engaging a tissue showing a needle, as disclosed herein;

[0074] FIG. 20C shows the embodiment of FIG. 20B having a lead positioned therethrough.

[0075] FIG. 21A shows an embodiment of a portion of an apparatus for removing fluid from a tissue, as disclosed herein;

[0076] FIG. 21B shows an embodiment of a portion of an apparatus comprising grooves for removing fluid from a tissue, as disclosed herein;

[0077] FIG. 22 shows an embodiment of a portion of an apparatus for removing fluid from a tissue inserted within a heart, as disclosed herein;

[0078] FIGS. 23 and 24 show embodiments of at least a portion of an exemplary system for use with a vacuum source for engaging a tissue, as disclosed herein;

[0079] FIG. 25 shows an exemplary system of the present disclosure having an inflated balloon, as disclosed herein;

[0080] FIG. 26 shows steps of an exemplary method of engaging a tissue to access a space adjacent thereto, as disclosed herein;

[0081] FIG. 27 shows an embodiment of at least a portion of an exemplary system for use with a vacuum source for engaging a tissue without a balloon, as disclosed herein;

[0082] FIG. 28 shows steps of an exemplary method of engaging a tissue to access a space adjacent thereto, as disclosed herein;

[0083] FIGS. 29A and 29B show embodiments of at least a portion of an exemplary system for use with a vacuum source for engaging a tissue positioned within a heart, as disclosed herein;

[0084] FIGS. 30 and 31 show embodiments of at least a portion of an exemplary multichannel system for engaging a tissue as disclosed herein;

[0085] FIG. 32 shows an embodiment of at least a portion of an exemplary dilator, as disclosed herein;

[0086] FIG. 33 shows a top view of an embodiment of a multichannel system for engaging a tissue, as disclosed herein;

[0087] FIG. 34 shows an embodiment of a multichannel system for engaging a tissue with partial removal of part of an embodiment of a dilator, as disclosed herein;

[0088] FIG. 35 shows an embodiment of an inducer sheath, as disclosed herein;

[0089] FIGS. 36-38 show embodiments of at least a portion of an exemplary multichannel system for engaging a tissue as disclosed herein;

[0090] FIG. 39 shows steps of an exemplary method of engaging a tissue to access a space adjacent thereto, as disclosed herein; and

[0091] FIG. 40 shows an embodiment of at least a portion of an exemplary multichannel system for engaging a tissue as disclosed herein;

#### DETAILED DESCRIPTION

[0092] For the purposes of promoting an understanding of the principles of the present disclosure, reference will now be made to the embodiments illustrated in the drawings, and specific language will be used to describe the same. It will nevertheless be understood that no limitation of the scope of this disclosure is thereby intended.

[0093] The disclosed embodiments include devices, systems, and methods useful for accessing various tissues of the heart from inside the heart. For example, various embodiments provide for percutaneous, intravascular access into the pericardial space through an atrial wall or the wall of an atrial appendage. In at least some embodiments, the heart wall is aspirated and retracted from the pericardial sac to increase the pericardial space between the heart and the sac and thereby facilitate access into the space.

[0094] Unlike the relatively stiff pericardial sac, the atrial wall and atrial appendage are rather soft and deformable. Hence, suction of the atrial wall or atrial appendage can provide significantly more clearance of the cardiac structure from the pericardium as compared to suction of the pericardium. Furthermore, navigation from the intravascular region (inside of the heart) provides more certainty of position of vital cardiac structures than does intrathoracic access (outside of the heart).

[0095] Access to the pericardial space may be used for identification of diagnostic markers in the pericardial fluid; for pericardiocentesis; and for administration of therapeutic factors with angiogenic, myogenic, and antiarrhythmic potential. In addition, as explained in more detail below, epicardial pacing leads may be delivered via the pericardial space, and an ablation catheter may be used on the epicardial tissue from the pericardial space.

[0096] In the embodiment of the catheter system shown in FIG. 1A, catheter system 10 includes an engagement catheter 20, a delivery catheter 30, and a needle 40. Although each of engagement catheter 20, delivery catheter 30, and needle 40 has a proximal end and a distal end, FIG. 1A shows only the distal end. Engagement catheter 20 has a lumen through which delivery catheter 30 has been inserted, and delivery catheter 30 has a lumen through which needle 40 has been inserted. Delivery catheter 30 also has a number of openings



**50** that can be used to transmit fluid from the lumen of the catheter to the heart tissue in close proximity to the distal end of the catheter.

[0097] As shown in more detail in FIGS. 2A, 2B, 2C, engagement catheter **20** includes a vacuum channel **60** used for suction of a targeted tissue **65** in the heart and an injection channel **70** used for infusion of substances to targeted tissue **65**, including, for example, a biological or non-biological degradable adhesive. As is shown in FIGS. 2B and 2C, injection channel **70** is ring-shaped, which tends to provide relatively even dispersal of the infused substance over the targeted tissue, but other shapes of injection channels may be suitable. A syringe **80** is attached to injection channel **70** for delivery of the appropriate substances to injection channel **70**, and a syringe **90** is attached to vacuum channel **60** through a vacuum port (not shown) at the proximal end of engagement catheter **20** to provide appropriate suction through vacuum channel **60**. At the distal end of engagement catheter **20**, a suction port **95** is attached to vacuum channel **60** for contacting targeted tissue **65**, such that suction port **95** surrounds targeted tissue **65**, which is thereby encompassed within the circumference of suction port **95**. Although syringe **90** is shown in FIG. 2B as the vacuum source providing suction for engagement catheter **20**, other types of vacuum sources may be used, such as a controlled vacuum system providing specific suction pressures. Similarly, syringe **80** serves as the external fluid source in the embodiment shown in FIG. 2B, but other external fluid sources may be used.

[0098] A route of entry for use of various embodiments disclosed herein is through the jugular or femoral vein to the superior or inferior vena cavae, respectively, to the right atrial wall or atrial appendage (percutaneously) to the pericardial sac (through puncture).

[0099] Referring now to FIG. 1B, an engagement catheter **100** is placed via standard approach into the jugular or femoral vein. The catheter, which may be 4 or 5 Fr., is positioned under fluoroscopic or echocardiographic guidance into the right atrial appendage **110**. Suction is initiated to aspirate a portion of atrial appendage **110** away from the pericardial sac **120** that surrounds the heart. As explained herein, aspiration of the heart tissue is evidenced when no blood can be pulled back through engagement catheter **100** and, if suction pressure is being measured, when the suction pressure gradually increases. A delivery catheter **130** is then inserted through a lumen of engagement catheter **100**. A small perforation can be made in the aspirated atrial appendage **110** with a needle such as needle **40**, as shown in FIGS. 1A and 2A. A guide wire (not shown) can then be advanced through delivery catheter **130** into the pericardial space to secure the point of entry **125** through the atrial appendage and guide further insertion of delivery catheter **130** or another catheter. Fluoroscopy or echocardiogram can be used to confirm the position of the catheter in the pericardial space. Alternatively, a pressure tip needle can sense the pressure and measure the pressure change from the atrium (about 10 mmHg) to the pericardial space (about 2 mmHg). This is particularly helpful for transseptal access where puncture of arterial structures (e.g., the aorta) can be diagnosed and sealed with an adhesive, as described in more detail below.

[0100] Although aspiration of the atrial wall or the atrial appendage retracts the wall or appendage from the pericardial sac to create additional pericardial space, CO<sub>2</sub> gas can be delivered through a catheter, such as delivery catheter **130**,

into the pericardial space to create additional space between the pericardial sac and the heart surface.

[0101] Referring now to FIG. 3A, the catheter system shown in FIG. 1B is retrieved by pull back through the route of entry. However, the puncture of the targeted tissue in the heart (e.g., the right atrial appendage as shown in FIG. 3A) may be sealed upon withdrawal of the catheter, which prevents bleeding into the pericardial space. The retrieval of the catheter may be combined with a sealing of the tissue in one of several ways: (1) release of a tissue adhesive or polymer **75** via injection channel **70** to seal off the puncture hole, as shown in FIG. 3B; (2) release of an inner clip or mechanical stitch to close off the hole from the inside of the cavity or the heart, as discussed herein; or (3) mechanical closure of the heart with a sandwich type mechanical device that approaches the hole from both sides of the wall (see FIGS. 4A, 4B, and 4C). In other words, closure may be accomplished by using, for example, a biodegradable adhesive material (e.g., fibrin glue or cyanomethacrylate), a magnetic system, or an umbrella-shaped nitinol stent. An example of the closure of a hole in the atrium is shown in FIG. 3B. Engagement catheter **20** is attached to targeted tissue **95** using suction through suction port **60**. Tissue adhesive **75** is injected through injection channel **70** to coat and seal the puncture wound in targeted tissue **95**. Engagement catheter **20** is then withdrawn, leaving a plug of tissue adhesive **75** attached to the atrial wall or atrial appendage.

[0102] Other examples for sealing the puncture wound in the atrial wall or appendage are shown in FIGS. 4A-4F. Referring now to FIGS. 4A-4C, a sandwich-type closure member, having an external cover **610** and an internal cover **620**, is inserted through the lumen of engagement catheter **600**, which is attached to the targeted tissue of an atrial wall **630**. Each of external and internal covers **610** and **620** is similar to an umbrella in that it can be inserted through a catheter in its folded configuration and expanded to an expanded configuration once it is outside of the catheter. As shown in FIG. 4A, external cover **610** is deployed (in its expanded configuration) on the outside of the atrial wall to seal a puncture wound in the targeted tissue, having already been delivered through the puncture wound into the pericardial space. Internal cover **620** is delivered through engagement catheter **600** (in its folded configuration), as shown in FIGS. 4A and 4B, by an elongated delivery wire **615**, to which internal cover **620** is reversibly attached (for example, by a screw-like mechanism). Once internal cover **620** is in position on the inside of atrial wall **630** at the targeted tissue, internal cover **620** is deployed to help seal the puncture wound in the targeted tissue (see FIG. 4C).

[0103] Internal cover **620** and external cover **610** may be made from a number of materials, including a shape-memory alloy such as nitinol. Such embodiments are capable of existing in a catheter in a folded configuration and then expanding to an expanded configuration when deployed into the body. Such a change in configuration can result from a change in temperature, for example. Other embodiments of internal and external covers may be made from other biocompatible materials and deployed mechanically.

[0104] After internal cover **620** is deployed, engagement catheter **600** releases its grip on the targeted tissue and is withdrawn, leaving the sandwich-type closure to seal the puncture wound, as shown in FIG. 4C. External cover **610** and internal cover **620** may be held in place using a biocompatible adhesive. Similarly, external cover **610** and internal cover **620** may be held in place using magnetic forces, such as, for

example, by the inside face (not shown) of external cover 610 comprising a magnet, by the inside face (not shown) of internal cover 620 comprising a magnet, or both inside faces of external cover 610 or internal cover 620 comprising magnets.

[0105] In the embodiment shown in FIGS. 4A, 4B, and 4C, the closure member comprises external cover 610 and internal cover 620. However, in at least certain other embodiments, the closure member need not have two covers. For example, as shown in FIG. 4D, closure member 632 is made of only one cover 634. Cover 634 has a first face 636 and a second face 638, and first face 636 is configured for reversible attachment to distal end 642 of delivery wire 640. Closure member 632 may be made of any suitable material, including nitinol, which is capable of transitioning from a folded configuration to an expanded configuration.

[0106] In the embodiment shown in FIG. 4E, a closure member 1500 comprises an external cover 1510 and an internal cover 1520 within a delivery catheter 1530. External cover 1510 and internal cover 1520 are attached at a joint 1540, which may be formed, for example, by a mechanical attachment or by a magnetic attachment. In embodiments having a magnetic attachment, each of the external cover and the internal cover may have a ferromagnetic component that is capable of magnetically engaging the other ferromagnetic component.

[0107] Delivery catheter 1530 is shown after insertion through hole 1555 of atrial wall 1550. Closure member 1500 may be advanced through delivery catheter 1530 to approach atrial wall 1550 by pushing rod 1560. Rod 1560 may be reversibly attached to internal cover 1520 so that rod 1560 may be disconnected from internal cover 1520 after closure member 1500 is properly deployed. For example, rod 1560 may engage internal cover 1520 with a screw-like tip such that rod 1560 may be easily unscrewed from closure member 1500 after deployment is complete. Alternatively, rod 1560 may simply engage internal cover 1520 such that internal cover 1520 may be pushed along the inside of delivery catheter 1530 without attachment between internal cover 1520 and rod 1560.

[0108] Closure member 1500 is advanced through delivery catheter 1530 until external cover 1510 reaches a portion of delivery catheter 1530 adjacent to atrial wall 1550; external cover 1510 is then pushed slowly out of delivery catheter 1530 into the pericardial space. External cover 1510 then expands and is positioned on the outer surface of atrial wall 1550. When external cover 1510 is properly positioned on atrial wall 1550, joint 1540 is approximately even with atrial wall 1550 within hole 1555. Delivery catheter 1530 is then withdrawn slowly, causing hole 1555 to close slightly around joint 1540. As delivery catheter 1530 continues to be withdrawn, internal cover 1520 deploys from delivery catheter 1530, thereby opening into its expanded formation. Consequently, atrial wall 1550 is pinched between internal cover 1520 and external cover 1510, and hole 1555 is closed to prevent leakage of blood from the heart.

[0109] FIG. 4F shows the occlusion of a hole (not shown) in atrial wall 1600 due to the sandwiching of atrial wall 1600 between an external cover 1610 and an internal cover 1620. External cover 1610 is shown deployed on the outside surface of atrial wall 1600, while internal cover 1620 is deployed on the inside surface of atrial wall 1600. As shown, rod 1640 is engaged with internal cover 1620, and delivery catheter 1630 is in the process of being withdrawn, which allows internal cover 1620 to fully deploy. Rod 1640 is then withdrawn

through delivery catheter 1630. An engagement catheter (not shown) may surround delivery catheter 1650, as explained more fully herein.

[0110] Other examples for sealing a puncture wound in the cardiac tissue are shown in FIGS. 12-15. Referring now to FIG. 12A, there is shown a plug 650 having a first end 652, a second end 654, and a hole 656 extending from first end 652 to second end 654. Plug 650 may be made from any suitable material, including casein, polyurethane, silicone, and polytetrafluoroethylene. Wire 660 has been slidably inserted into hole 656 of plug 650. Wire 660 may be, for example, a guide wire or a pacing lead, so long as it extends through the hole in the cardiac tissue (not shown). As shown in FIG. 12A, first end 652 is covered with a radiopaque material, such as barium sulfate, and is therefore radiopaque. This enables the clinician to view the placement of the plug in the body using radiographic imaging. For example, the clinician can confirm the location of the plug during the procedure, enabling a safer and more effective procedure for the patient.

[0111] As shown in FIG. 12A, first end 652 of plug 650 has a smaller diameter than second end 654 of plug 650. Indeed, plug 680 shown FIG. 12B and plug 684 shown in FIGS. 13 and 14 have first ends that are smaller in diameter than their respective second ends. However, not all embodiments of plug have a first end that is smaller in diameter than the second end. For example, plug 682 shown in FIG. 12C has a first end with a diameter that is not smaller than the diameter of the second end. Both types of plug can be used to close holes in cardiac tissue.

[0112] Referring again to FIG. 12A, elongated shaft 670 has a proximal end (not shown), a distal end 672, and a lumen 674 extending from the proximal end to distal end 672. Although no catheter is shown in FIG. 12A, plug 650, wire 660, and shaft 670 are configured for insertion into a lumen of a catheter (see FIG. 14), such as an embodiment of an engagement catheter disclosed herein. Plug 650 and shaft 670 are also configured to be inserted over wire 660 and can slide along wire 660 because each of lumen 656 of plug 650 and lumen 674 of shaft 670 is slightly larger in circumference than wire 660.

[0113] As shown in FIGS. 13 and 14, shaft 672 is used to push plug 684 along wire 674 within elongated tube 676 to and into the hole in the targeted cardiac tissue 678. Distal end 677 of elongated tube 676 is shown attached to cardiac tissue 678, but distal end 677 need not be attached to cardiac tissue 678 so long as distal end 677 is adjacent to cardiac tissue 678. Once plug 684 is inserted into the hole, wire 674 may be withdrawn from the hole in plug 684 and the interior of the heart (not shown) and shaft 672 is withdrawn from elongated tube 676. In some embodiments, the plug is self-sealing, meaning that the hole of the plug closes after the wire is withdrawn. For example, the plug may be made from a dehydrated protein matrix, such as casein or ameroid, which swells after soaking up fluid. After shaft 672 is withdrawn, elongated tube 676 can be withdrawn from the heart.

[0114] It should be noted that, in some embodiments, the wire is not withdrawn from the hole of the plug. For example, where the wire is a pacing lead, the wire may be left within the plug so that it operatively connects to the CRT device.

[0115] Referring now to FIG. 12B, there is shown a plug 680 that is similar to plug 684. However, plug 680 comprises external surface 681 having a ridge 683 that surrounds plug 680 in a helical or screw-like shape. Ridge 683 helps to anchor plug 680 into the hole of the targeted tissue (not

shown). Other embodiments of plug may include an external surface having a multiplicity of ridges surrounding the plug, for example, in a circular fashion.

[0116] FIGS. 15A-15C show yet another embodiment of a closure member for closing a hole in a tissue. Spider clip 1700 is shown within catheter 1702 and comprises a head 1705 and a plurality of arms 1710, 1720, 1730, and 1740. Each of arms 1710, 1720, 1730, and 1740 is attached at its proximal end to head 1705. Although spider clip 1700 has four arms, other embodiments of spider clip include fewer than, or more than, four arms. For example, some embodiments of spider clip have three arms, while others have five or more arms.

[0117] Referring again to FIGS. 15A-15C, arms 1710, 1720, 1730, and 1740 may be made from any flexible biocompatible metal that can transition between two shapes, such as a shape-memory alloy (e.g., nitinol) or stainless steel. Spider clip 1700 is capable of transitioning between an open position (see FIG. 15A), in which the distal ends of its arms 1710, 1720, 1730, and 1740 are spaced apart, and a closed position (see FIG. 15C), in which the distal ends of arms 1710, 1720, 1730, and 1740 are gathered together. For embodiments made from a shape-memory alloy, the clip can be configured to transition from the open position to the closed position when the metal is warmed to approximately body temperature, such as when the clip is placed into the cardiac tissue. For embodiments made from other types of metal, such as stainless steel, the clip is configured in its closed position, but may be transitioned into an open position when pressure is exerted on the head of the clip. Such pressure causes the arms to bulge outward, thereby causing the distal ends of the arms to separate.

[0118] In this way, spider clip 1700 may be used to seal a wound or hole in a tissue, such as a hole through the atrial wall. For example, FIG. 15B shows spider clip 1700 engaged by rod 1750 within engagement catheter 1760. As shown, engagement catheter 1760 has a bell-shaped suction port 1765, which, as disclosed herein, has aspirated cardiac tissue 1770. Cardiac tissue 1770 includes a hole 1775 therethrough, and suction port 1765 fits over hole 1775 so as to expose hole 1775 to spider clip 1700.

[0119] Rod 1750 pushes spider clip 1700 through engagement catheter 1760 to advance spider clip 1700 toward cardiac tissue 1770. Rod 1750 simply engages head 1705 by pushing against it, but in other embodiments, the rod may be reversibly attached to the head using a screw-type system. In such embodiments, the rod may be attached and detached from the head simply by screwing the rod into, or unscrewing the rod out of, the head, respectively.

[0120] In at least some embodiments, the spider clip is held in its open position during advancement through the engagement catheter by the pressure exerted on the head of the clip by the rod. This pressure may be opposed by the biasing of the legs against the engagement catheter during advancement.

[0121] Referring to FIG. 15C, spider clip 1700 approaches cardiac tissue 1770 and eventually engages cardiac tissue 1770 such that the distal end of each of arms 1710, 1720, 1730, and 1740 contacts cardiac tissue 1770. Rod 1750 is disengaged from spider clip 1700, and spider clip 1700 transitions to its closed position, thereby drawing the distal ends of arms 1710, 1720, 1730, and 1740 together. As the distal ends of the arms are drawn together, the distal ends grip portions of cardiac tissue 1770, thereby collapsing the tissue between arms 1710, 1720, 1730, and 1740 such that hole 1775 is effectively closed.

[0122] Rod 1750 is then withdrawn, and engagement catheter 1760 is disengaged from cardiac tissue 1770. The constriction of cardiac tissue 1770 holds hole 1775 closed so that blood does not leak through hole 1775 after engagement catheter 1760 is removed. After a relatively short time, the body's natural healing processes permanently close hole 1775. Spider clip 1700 may remain in the body indefinitely.

[0123] FIGS. 16A, 16B, and 16C show an embodiment of a portion of an apparatus for engaging a tissue as disclosed herein. As shown in FIG. 16A, a sleeve 1800 is present around at least a portion of an engagement catheter 1810. Sleeve 1800, as described herein, may comprise a rigid or flexible tube having a lumen therethrough, appearing around the outside of engagement catheter 1810 and slidingly engaging engagement catheter 1810. In at least the embodiment shown in FIG. 16A, the distal end 1820 of engagement catheter 1810 comprises a skirt 1830, shown in FIG. 16A as being housed within sleeve 1800. A delivery catheter 1840 may be present within engagement catheter 1810 as shown to facilitate the delivery of a product (gas, liquid, and/or particulate(s)) to a target site. In this embodiment, delivery catheter 1840 is present at least partially within the lumen of engagement catheter 1810, and engagement catheter is placed at least partially within the lumen of sleeve 1800.

[0124] Referring now to FIG. 16B, an embodiment of an apparatus as shown in FIG. 16A or similar to the embodiment shown in FIG. 16A is shown with sleeve 1800 being "pulled back" from the distal end of engagement catheter 1810. As shown in FIG. 16B, as sleeve 1800 is pulled back (in the direction of the arrow), skirt 1830 becomes exposed, and as sleeve 1800 is no longer present around skirt 1830, skirt 1830 may optionally expand into a frusto-conical ("bell-shaped") skirt 1830. Skirt 1830 may be reversibly deformed (collapsed) when present within the lumen of sleeve 1800 as shown in FIG. 16A and in FIG. 18A described in further detail herein. It can be appreciated that many alternative configurations of skirt 1830 to the frusto-conical configuration may exist, including an irregular frusto-conical configuration, noting that a configuration of skirt 1830 having a distal portion (closest to a tissue to be engaged) larger than a proximal position may benefit from suction of a larger surface area of a tissue as described in further detail herein.

[0125] FIG. 16C shows an embodiment of an apparatus described herein having an expanded skirt 1830. As shown in FIG. 16C, sleeve 1800 has been pulled back (in the direction of the arrow) so that the expanded configuration of skirt 1830 may be present to engage a tissue (not shown).

[0126] FIGS. 17A and 17B shown alternative embodiments of a portion of an apparatus for engaging a tissue as described herein. FIGS. 17A and 17B each show a sleeve 1800, an engagement catheter 1810 having a skirt 1830, and a delivery catheter 1840. In each figure, skirt 1830 is shown engaging a surface of a tissue 1850. In the embodiments shown in FIGS. 17A and 17B, the relative sizes of the sleeves 1800, engagement catheters 1810, and delivery catheters 1840 are similar as shown, but the relative sizes of the skirts 1830 of the engagement catheters 1810 are clearly different. The exemplary embodiment of the portion of an apparatus for engaging a tissue shown in FIG. 17A comprises a skirt 1830 of the same or substantially similar relative size as the engagement catheter 1810, meaning that the diameters of the engagement catheter 1810 and the skirt 1830 shown in FIG. 17A are approximately the same. Conversely, the exemplary embodiment of the portion of an apparatus for engaging a tissue

shown in FIG. 17B comprises a skirt 1830 notably larger than the engagement catheter 1810, meaning that the diameters of the engagement catheter 1810 and the skirt 1830 at its widest point shown in FIG. 17B are notably different. As shown in FIG. 17B, as skirt 1830 extends from engagement catheter 1810 to tissue 1850, the diameter of skirt 1830 increases. As such, skirt 1830 of the embodiment shown in FIG. 17B may engage a larger surface area of a tissue (shown by 1860) than the embodiment of the skirt 1830 shown in FIG. 17A. The ability to engage a larger surface area of a tissue 1850 by skirt 1830 allows a better reversible engagement of a tissue 1850 when a vacuum is provided as described in detail herein. This improved suction allows a person using such an apparatus to more effectively engage a tissue 1850 than would otherwise be possible when skirt 1830 engages a smaller surface area of a tissue.

[0127] FIGS. 18A and 18B show perspective views of an embodiment of a portion of an apparatus for engaging a tissue. FIG. 18A represents an embodiment whereby a skirt 1830 of an engagement catheter 1810 is positioned substantially within a sleeve 1800. FIG. 18B represents an embodiment whereby a skirt 1830 of an engagement catheter 1810 is positioned outside of sleeve 1800. As such, the positioning of skirt 1830 within sleeve 1800 can be seen in the embodiments of FIGS. 16A and 18A, and the positioning of skirt 1830 outside of sleeve 1800 can be seen in the embodiments of FIGS. 16C and 18B.

[0128] As shown in FIG. 18A, skirt 1830 of engagement catheter 1810 is positioned within sleeve 1800, whereby the configuration of skirt 1830 is collapsed so that skirt 1830 may fit within sleeve 1800. As sleeve 1800 moves in the direction of the arrow shown in FIG. 18B, skirt 1830 becomes exposed and its configuration is allowed to expand because there are no constraints provided by the inner wall of sleeve 1800.

[0129] The embodiments shown in FIGS. 18A and 18B also show an exemplary embodiment of a configuration of an engagement catheter 1810. As shown in FIG. 18B, engagement catheter 1810 defines a number of apertures (representing lumens) present at the distal end of engagement catheter 1810 (at the proximal end of skirt 1830), including, but not limited to, one or more vacuum ports 1870 (representing the aperture at or near the distal end of a vacuum tube), and a delivery port 1880 (representing the aperture at or near the distal end of a delivery tube). A vacuum source (not shown) may be coupled to a suction port located at a proximal end of one or more vacuum tubes as described herein, whereby gas, fluid, and/or particulate(s) may be introduced into one or more vacuum ports 1870 by the introduction of a vacuum at a vacuum port. Gas, fluid, and/or particulate(s) may be introduced from delivery aperture 1880 to a tissue (not shown in FIG. 18A or 18B).

[0130] As shown by the exemplary embodiments of FIGS. 17A and 17B, the ability for a user of such an apparatus for engaging a tissue to obtain proper suction depends at least in part on the relative placement of skirt 1830 and delivery catheter 1840 at or near a tissue 1850. As described in detail herein regarding the exemplary embodiment shown in FIG. 5D, if a vacuum source provides suction through one or more vacuum ports 1870 (shown in FIGS. 18A and 18B), but skirt 1830 has not effectively engaged a tissue 1850, gas, fluid, and/or particulate(s) in the area of tissue 1850 and/or gas, fluid and/or particulate(s) delivered via delivery catheter 1840 to the area of tissue 1850 may be aspirated by one or more vacuum ports 1870. In a situation where skirt 1830 has

effectively engaged a tissue 1850 but where delivery catheter 1840 has not engaged a tissue 1850, any gas, liquid, and/or particulate(s) delivered by delivery catheter 1840 may be aspirated by one or more vacuum ports 1870. In a situation where skirt 1830 and delivery catheter 1840 have effectively engaged a tissue 1850, most, if not all, of any gas, liquid, and/or particulate(s) delivered by delivery catheter 1840 to tissue 1850 would not be aspirated by one or more vacuum ports 1870 as the placement of delivery catheter 1840 on or within tissue 1850 would provide direct delivery at or within tissue 1850.

[0131] An exemplary embodiment of a system and/or device for engaging a tissue as described herein is shown in FIG. 19. As shown in FIG. 19, an exemplary apparatus shows a sleeve 1800 which has been moved in the direction of the arrow to reveal skirt 1830 at the distal end of engagement catheter 1810, allowing skirt to resume an expanded, frusto-conical configuration. As shown in this embodiment, delivery catheter 1840 has been introduced at the proximal end of the apparatus (in the direction shown by the dashed arrow), allowing delivery catheter 1840 to exit out of a delivery lumen (not shown) at the distal end of engagement catheter 1840. A needle 1890 may be present at the distal end of delivery catheter 1840, facilitating the potential puncture of a tissue (not shown) to allow the distal end of delivery catheter 1840 to enter a tissue.

[0132] In addition, and as shown in the exemplary embodiment of FIG. 19, a lead 1900 may be introduced into delivery catheter 1840 (in the direction shown by the dashed arrow), whereby the distal end of lead 1900 may exit an aperture of needle 1890 and optionally enter a tissue and/or a lumen of a tissue. As described herein, any number of suitable types of leads 1900 may be used with the delivery catheters described herein, including sensing leads and/or pacing leads. A vacuum source 1910 may also provide a source of vacuum to such an apparatus to allow skirt 1830 to engage a tissue using suction.

[0133] The exemplary embodiment of an apparatus for engaging a tissue as shown in FIG. 19 comprises an engagement catheter 1810 having a curvature. Such a curved engagement catheter 1810 allows a user of such an apparatus, for example, to insert a portion of the apparatus into a body or tissue from one direction, and engage a tissue with skirt 1830, delivery catheter 1840, needle 1890, and/or lead 1900 from another direction. For example, a user may introduce a portion of an apparatus from one side of the heart, and the apparatus may engage the heart from a different direction than the direction of introduction of the apparatus.

[0134] It can also be appreciated that an exemplary embodiment of an apparatus of the present disclosure may be used to engage an internal portion of an organ. As previously referenced herein, such an apparatus may be used to engage the surface of a tissue. However, it can be appreciated that such a tissue may be an outer surface of any number of tissues, including, but not limited to, a heart, lungs, intestine, stomach, or any number of other organs or tissues. It can also be appreciated that some of these types of organs or tissues, including the heart for example, may have one or more internal tissue surfaces capable of being engaged by an apparatus of the present disclosure. For example, a user of such an apparatus may use the apparatus to engage the septum of the heart dividing one side of the heart from another. Such use may facilitate the delivery of a gas, liquid, and/or particulate (s) to a particular side of the heart, as such a targeted delivery

may provide beneficial effects, including, but not limited to, the ability to deliver a lead to pace the inner wall of the left side of the heart.

[0135] Referring now to FIGS. 20A, 20B, and 20C, embodiments of a portion of an apparatus for engaging a tissue according to the present disclosure are shown. As shown in FIG. 20A, an exemplary embodiment of a portion of an apparatus for engaging a tissue comprises sleeve 1800 slidably engaging engagement catheter 1810, and when sleeve 1800 is slid in the direction of the arrow shown, skirt 1830 is revealed, having an expanded, optionally frusto-conical configuration as shown. Delivery catheter 1840 may exit out of a delivery lumen (not shown), with needle 1890 present at the distal end of delivery catheter 1840. As shown in the embodiment of FIG. 20A, lead 1900 is present, exiting out of an aperture of needle 1890.

[0136] FIGS. 20B and 20C show a closer view of an embodiment of a portion of an apparatus for engaging a tissue according to the present disclosure than is shown in FIG. 20A. As shown in FIGS. 20B and 20C, aperture 1920 of needle 1890 is shown, and as shown in FIG. 20C, lead 1900 may exit aperture 1920 of needle 1890.

[0137] Referring now to FIGS. 5A, 5B, 5C, and 5D, there is shown another embodiment of an engagement catheter as disclosed herein. Engagement catheter 700 is an elongated tube having a proximal end 710 and a distal end 720, as well as two lumens 730, 740 extending between proximal end 710 and distal end 720. Lumens 730, 740 are formed by concentric inner wall 750 and outer wall 760, as particularly shown in FIGS. 5B and 5C. At proximal end 710, engagement catheter 700 includes a vacuum port 770, which is attached to lumen 730 so that a vacuum source can be attached to vacuum port 770 to create suction in lumen 730, thereby forming a suction channel. At distal end 720 of catheter 700, a suction port 780 is attached to lumen 730 so that suction port 780 can be placed in contact with heart tissue 775 (see FIG. 5D) for aspirating the tissue, thereby forming a vacuum seal between suction port 780 and tissue 775 when the vacuum source is attached and engaged. The vacuum seal enables suction port 780 to grip, stabilize, and retract tissue 775. For example, attaching a suction port to an interior atrial wall using a vacuum source enables the suction port to retract the atrial wall from the pericardial sac surrounding the heart, which enlarges the pericardial space between the atrial wall and the pericardial sac.

[0138] As shown in FIG. 5C, two internal lumen supports 810, 820 are located within lumen 730 and are attached to inner wall 750 and outer wall 760 to provide support to the walls. These lumen supports divide lumen 730 into two suction channels. Although internal lumen supports 810, 820 extend from distal end 720 of catheter 700 along a substantial portion of the length of catheter 700, internal lumen supports 810, 820 may or may not span the entire length of catheter 700. Indeed, as shown in FIGS. 5A, 5B, and 5C, internal lumen supports 810, 820 do not extend to proximal end 710 to ensure that the suction from the external vacuum source is distributed relatively evenly around the circumference of catheter 700. Although the embodiment shown in FIG. 5C includes two internal lumen supports, other embodiments may have just one internal support or even three or more such supports.

[0139] FIG. 5D shows engagement catheter 700 approaching heart tissue 775 for attachment thereto. It is important for the clinician performing the procedure to know when the

suction port has engaged the tissue of the atrial wall or the atrial appendage. For example, in reference to FIG. 5D, it is clear that suction port 780 has not fully engaged tissue 775 such that a seal is formed. However, because suction port 780 is not usually seen during the procedure, the clinician may determine when the proper vacuum seal between the atrial tissue and the suction port has been made by monitoring the amount of blood that is aspirated, by monitoring the suction pressure with a pressure sensor/regulator, or both. For example, as engagement catheter 700 approaches the atrial wall tissue (such as tissue 775) and is approximately in position, the suction can be activated through lumen 730. A certain level of suction (e.g., 10 mmHg) can be imposed and measured with a pressure sensor/regulator. As long as catheter 700 does not engage the wall, some blood will be aspirated into the catheter and the suction pressure will remain the same. However, when catheter 700 engages or attaches to the wall of the heart (depicted as tissue 775 in FIG. 5D), minimal blood is aspirated and the suction pressure will start to gradually increase. Each of these signs can alert the clinician (through alarm or other means) as an indication of engagement. The pressure regulator is then able to maintain the suction pressure at a preset value to prevent over-suction of the tissue.

[0140] An engagement catheter, such as engagement catheter 700, may be configured to deliver a fluid or other substance to tissue on the inside of a wall of the heart, including an atrial wall or a ventricle wall. For example, lumen 740 shown in FIGS. 5A and 5C includes an injection channel 790 at distal end 720. Injection channel 790 dispenses to the targeted tissue a substance flowing through lumen 740. As shown in FIG. 5D, injection channel 790 is the distal end of lumen 740. However, in other embodiments, the injection channel may be ring-shaped (see FIG. 2C) or have some other suitable configuration.

[0141] Substances that can be locally administered with an engagement catheter include preparations for gene or cell therapy, drugs, and adhesives that are safe for use in the heart. The proximal end of lumen 740 has a fluid port 800, which is capable of attachment to an external fluid source for supply of the fluid to be delivered to the targeted tissue. Indeed, after withdrawal of a needle from the targeted tissue, as discussed herein, an adhesive may be administered to the targeted tissue by the engagement catheter for sealing the puncture wound left by the needle withdrawn from the targeted tissue.

[0142] Referring now to FIGS. 6A, 6B, and 6C, there is shown a delivery catheter 850 comprising an elongated hollow tube 880 having a proximal end 860, a distal end 870, and a lumen 885 along the length of the catheter. Extending from distal end 870 is a hollow needle 890 in communication with lumen 885. Needle 890 is attached to distal end 870 in the embodiment of FIGS. 6A, 6B, and 6C, but, in other embodiments, the needle may be removably attached to, or otherwise located at, the distal end of the catheter (see FIG. 1A). In the embodiment shown in FIGS. 6A, 6B, and 6C, as in certain other embodiments having an attached needle, the junction (i.e., site of attachment) between hollow tube 880 and needle 890 forms a security notch 910 circumferentially around needle 890 to prevent needle 890 from over-perforation. Thus, when a clinician inserts needle 890 through an atrial wall to gain access to the pericardial space, the clinician will not, under normal conditions, unintentionally perforate the pericardial sac with needle 890 because the larger diameter of hollow tube 880 (as compared to that of needle 890) at secu-

urity notch **910** hinders further needle insertion. Although security notch **910** is formed by the junction of hollow tube **880** and needle **890** in the embodiment shown in FIGS. **6A**, **6B**, and **6C**, other embodiments may have a security notch that is configured differently. For example, a security notch may include a band, ring, or similar device that is attached to the needle a suitable distance from the tip of the needle. Like security notch **910**, other security notch embodiments hinder insertion of the needle past the notch itself by presenting a larger profile than the profile of the needle such that the notch does not easily enter the hole in the tissue caused by entry of the needle.

**[0143]** It is useful for the clinician performing the procedure to know when the needle has punctured the atrial tissue. This can be done in several ways. For example, the delivery catheter can be connected to a pressure transducer to measure pressure at the tip of the needle. Because the pressure is lower and much less pulsatile in the pericardial space than in the atrium, the clinician can recognize immediately when the needle passes through the atrial tissue into the pericardial space.

**[0144]** Alternatively, as shown in FIG. **6B**, needle **890** may be connected to a strain gauge **915** as part of the catheter assembly. When needle **890** contacts tissue (not shown), needle **890** will be deformed. The deformation will be transmitted to strain gauge **915** and an electrical signal will reflect the deformation (through a classical wheatstone bridge), thereby alerting the clinician. Such confirmation of the puncture of the wall can prevent over-puncture and can provide additional control of the procedure.

**[0145]** In some embodiments, a delivery catheter, such as catheter **850** shown in FIGS. **6A**, **6B**, and **6C**, is used with an engagement catheter, such as catheter **700** shown in FIGS. **5A**, **5B**, **5C**, and **5D**, to gain access to the pericardial space between the heart wall and the pericardial sac. For example, engagement catheter **700** may be inserted into the vascular system and advanced such that the distal end of the engagement catheter is within the atrium. The engagement catheter may be attached to the targeted tissue on the interior of a wall of the atrium using a suction port as disclosed herein. A standard guide wire may be inserted through the lumen of the delivery catheter as the delivery catheter is inserted through the inner lumen of the engagement catheter, such as lumen **740** shown in FIGS. **5B** and **5C**. Use of the guide wire enables more effective navigation of the delivery catheter **850** and prevents the needle **890** from damaging the inner wall **750** of the engagement catheter **700**. When the tip of the delivery catheter with the protruding guide wire reaches the atrium, the wire is pulled back, and the needle is pushed forward to perforate the targeted tissue. The guide wire is then advanced through the perforation into the pericardial space, providing access to the pericardial space through the atrial wall.

**[0146]** Referring again to FIGS. **6A**, **6B**, and **6C**, lumen **885** of delivery catheter **850** may be used for delivering fluid into the pericardial space after needle **890** is inserted through the atrial wall or the atrial appendage. After puncture of the wall or appendage, a guide wire (not shown) may be inserted through needle lumen **900** into the pericardial space to maintain access through the atrial wall or appendage. Fluid may then be introduced to the pericardial space in a number of ways. For example, after the needle punctures the atrial wall or appendage, the needle is generally withdrawn. If the needle is permanently attached to the delivery catheter, as in the embodiment shown in FIGS. **6A** and **6B**, then delivery cath-

eter **850** would be withdrawn and another delivery catheter (without an attached needle) would be introduced over the guide wire into the pericardial space. Fluid may then be introduced into the pericardial space through the lumen of the second delivery catheter.

**[0147]** In some embodiments, however, only a single delivery catheter is used. In such embodiments, the needle is not attached to the delivery catheter, but instead may be a needle wire (see FIG. **1A**). In such embodiments, the needle is withdrawn through the lumen of the delivery catheter, and the delivery catheter may be inserted over the guide wire into the pericardial space. Fluid is then introduced into the pericardial space through the lumen of the delivery catheter.

**[0148]** The various embodiments disclosed herein may be used by clinicians, for example: (1) to deliver genes, cells, drugs, etc.; (2) to provide catheter access for epicardial stimulation; (3) to evacuate fluids acutely (e.g., in cases of pericardial tamponade) or chronically (e.g., to alleviate effusion caused by chronic renal disease, cancer, etc.); (4) to perform transeptal puncture and delivery of a catheter through the left atrial appendage for electrophysiological therapy, biopsy, etc.; (5) to deliver a magnetic glue or ring through the right atrial appendage to the aortic root to hold a percutaneous aortic valve in place; (6) to deliver a catheter for tissue ablation, e.g., to the pulmonary veins, or right atrial and epicardial surface of the heart for atrial and ventricular arrhythmias; (7) to deliver and place epicardial, right atrial, and right and left ventricle pacing leads (as discussed herein); (8) to occlude the left atrial appendage through percutaneous approach; and (9) to visualize the pericardial space with endo-camera or scope to navigate the epicardial surface of the heart for therapeutic delivery, diagnosis, lead placement, mapping, etc. Many other applications, not explicitly listed here, are also possible and within the scope of the present disclosure.

**[0149]** Referring now to FIG. **7**, there is shown a delivery catheter **1000**. Delivery catheter **1000** includes an elongated tube **1010** having a wall **1020** extending from a proximal end (not shown) of tube **1010** to a distal end **1025** of tube **1010**. Tube **1010** includes two lumens, but other embodiments of delivery catheters may have fewer than, or more than, two lumens, depending on the intended use of the delivery catheter. Tube **1010** also includes a steering channel **1030**, in which a portion of steering wire system **1040** is located. Steering channel **1030** forms orifice **1044** at distal end **1025** of tube **1010** and is sized to fit over a guide wire **1050**.

**[0150]** FIG. **8** shows in more detail steering wire system **1040** within steering channel **1030** (which is shown cut away from the remainder of the delivery catheter). Steering wire system **1040** is partially located in steering channel **1030** and comprises two steering wires **1060** and **1070** and a controller **1080**, which, in the embodiment shown in FIG. **8**, comprises a first handle **1090** and a second handle **1094**. First handle **1090** is attached to proximal end **1064** of steering wire **1060**, and second handle **1094** is attached to proximal end **1074** of steering wire **1070**. Distal end **1066** of steering wire **1060** is attached to the wall of the tube of the delivery catheter within steering channel **1030** at attachment **1100**, and distal end **1076** of steering wire **1070** is attached to the wall of the tube of the delivery catheter within steering channel **1030** at attachment **1110**. As shown in FIG. **7**, attachment **1100** and attachment **1110** are located on opposing sides of steering channel **1030** near distal tip **1120** of delivery catheter **1000**.

**[0151]** In the embodiment of FIG. **8**, steering wires **1060** and **1070** are threaded as a group through steering channel

**1030.** However, the steering wire systems of other embodiments may include steering wires that are individually threaded through smaller lumens within the steering channel. For example, FIG. 11 shows a cross-sectional view of a delivery catheter **1260** having an elongated tube **1264** comprising a wall **1266**, a steering channel **1290**, a first lumen **1270**, and a second lumen **1280**. Delivery catheter **1260** further includes a steering wire **1292** within a steering wire lumen **1293**, a steering wire **1294** within a steering wire lumen **1295**, and a steering wire **1296** within a steering wire lumen **1297**. Each of steering wire lumens **1293**, **1295**, and **1297** is located within steering channel **1290** and is formed from wall **1266**. Each of steering wires **1292**, **1294**, and **1296** is attached to wall **1266** within steering channel **1290**. As will be explained, the attachment of each steering wire to the wall may be located near the distal tip of the delivery catheter, or may be located closer to the middle of the delivery catheter.

**[0152]** Referring now to FIGS. 7 and 8, steering wire system **1040** can be used to control distal tip **1120** of delivery catheter **1000**. For example, when first handle **1090** is pulled, steering wire **1060** pulls distal tip **1120**, which bends delivery catheter **1000**, causing tip deflection in a first direction. Similarly, when second handle **1094** is pulled, steering wire **1070** pulls distal tip **1120** in the opposite direction, which bends delivery catheter **1000**, causing tip deflection in the opposite direction. Thus, delivery catheter **1000** can be directed (i.e., steered) through the body using steering wire system **1040**.

**[0153]** Although steering wire system **1040** has only two steering wires, other embodiments of steering wire systems may have more than two steering wires. For example, some embodiments of steering wire systems may have three steering wires (see FIG. 11), each of which is attached to the steering channel at a different attachment. Other embodiments of steering wire systems may have four steering wires. Generally, more steering wires give the clinician more control for directing the delivery catheter because each additional steering wire enables the user to deflect the tip of the delivery catheter in an additional direction. For example, four steering wires could be used to direct the delivery catheter in four different directions (e.g., up, down, right, and left).

**[0154]** If a steering wire system includes more than two steering wires, the delivery catheter may be deflected at different points in the same direction. For instance, a delivery catheter with three steering wires may include two steering wires for deflection in a certain direction and a third steering wire for reverse deflection (i.e., deflection in the opposite direction). In such an embodiment, the two steering wires for deflection are attached at different locations along the length of the delivery catheter. Referring now to FIGS. 9A-9C, there is shown a steering wire system **1350** within steering channel **1360** (which is shown cut away from the remainder of the delivery catheter) in different states of deflection. Steering wire system **1350** is partially located in steering channel **1360** and comprises three steering wires **1370**, **1380**, and **1390** and a controller **1400**, which, in the embodiment shown in FIGS. 9A-9C, comprises a handle **1405**. Handle **1405** is attached to proximal end **1374** of steering wire **1370**, proximal end **1384** of steering wire **1380**, and proximal end **1394** of steering wire **1390**. Distal end **1376** of steering wire **1370** is attached to the wall of the tube of the delivery catheter within steering channel **1360** at attachment **1378**, which is near the distal tip of the delivery catheter (not shown). Distal end **1386** of steering wire **1380** is attached to the wall of the tube of the delivery catheter within steering channel **1360** at attachment **1388**,

which is near the distal tip of the delivery catheter (not shown). Attachment **1378** and attachment **1388** are located on opposing sides of steering channel **1360** such that steering wires **1370** and **1380**, when tightened (as explained below), would tend to deflect the delivery catheter in opposite directions. Distal end **1396** of steering wire **1390** is attached to the wall of the tube of the delivery catheter within steering channel **1360** at attachment **1398**, which is located on the delivery catheter at a point closer to the proximal end of the delivery catheter than attachments **1378** and **1388**. Attachment **1398** is located on the same side of steering channel **1360** as attachment **1388**, such that steering wires **1380** and **1390**, when tightened (as explained below), would tend to deflect the delivery catheter in the same direction. However, because attachment **1398** is closer to the proximal end of the delivery catheter than is attachment **1388**, the tightening of steering wire **1390** tends to deflect the delivery catheter at a point closer to the proximal end of the delivery catheter than does the tightening of steering wire **1380**. Thus, as shown in FIG. 9A, the tightening of steering wire **1390** causes a deflection in the delivery catheter approximately at point **1410**. The tightening of steering wire **1380** at the same time causes a further deflection in the delivery catheter approximately at point **1420**, as shown in FIG. 9B. The tightening of steering wire **1370**, therefore, causes a reverse deflection, returning the delivery catheter to its original position (see FIG. 9C).

**[0155]** Referring again to FIG. 7, elongated tube **1010** further includes lumen **1130** and lumen **1140**. Lumen **1130** extends from approximately the proximal end (not shown) of tube **1010** to or near distal end **1025** of tube **1010**. Lumen **1130** has a bend **1134**, relative to tube **1010**, at or near distal end **1025** of tube **1010** and an outlet **1136** through wall **1020** of tube **1010** at or near distal end **1025** of tube **1010**. Similarly, lumen **1140** has a bend **1144**, relative to tube **1010**, at or near distal end **1025** of tube **1010** and an outlet **1146** through wall **1020** of tube **1010** at or near distal end **1025** of tube **1010**. In the embodiment shown in FIG. 7, lumen **1130** is configured as a laser Doppler tip, and lumen **1140** is sized to accept a retractable sensing lead **1150** and a pacing lead **1160** having a tip at the distal end of the lead. The fiberoptic laser Doppler tip detects and measures blood flow (by measuring the change in wavelength of light emitted by the tip), which helps the clinician to identify—and then avoid—blood vessels during lead placement. Sensing lead **1150** is designed to detect electrical signals in the heart tissue so that the clinician can avoid placing a pacing lead into electrically nonresponsive tissue, such as scar tissue. Pacing lead **1160** is a screw-type lead for placement onto the cardiac tissue, and its tip, which is an electrode, has a substantially screw-like shape. Pacing lead **1160** is capable of operative attachment to a CRT device (not shown) for heart pacing. Although lead **1160** is used for cardiac pacing, any suitable types of leads may be used with the delivery catheters described herein, including sensing leads.

**[0156]** Each of bend **1134** of lumen **1130** and bend **1144** of lumen **1140** forms an approximately 90-degree angle, which allows respective outlets **1136** and **1146** to face the external surface of the heart as the catheter is maneuvered in the pericardial space. However, other embodiments may have bends forming other angles, smaller or larger than 90-degrees, so long as the lumen provides proper access to the external surface of the heart from the pericardial space. Such angles may range, for example, from about 25-degrees to about 155-degrees. In addition to delivering leads and Dop-

pler tips, lumen 1130 and lumen 1140 may be configured to allow, for example, the taking of a cardiac biopsy, the delivery of gene cell treatment or pharmacological agents, the delivery of biological glue for ventricular reinforcement, implementation of ventricular epicardial suction in the acute myocardial infarction and border zone area, the removal of fluid in treatment of pericardial effusion or cardiac tamponade, or the ablation of cardiac tissue in treatment of atrial fibrillation.

[0157] For example, lumen 1130 could be used to deliver a catheter needle for intramyocardial injection of gene cells, stems, biomaterials, growth factors (such as cytokinase, fibroblast growth factor, or vascular endothelial growth factor) and/or biodegradable synthetic polymers, RGD-liposome biologic glue, or any other suitable drug or substance for treatment or diagnosis. For example, suitable biodegradable synthetic polymer may include polylactides, polyglycolides, polycaprolactones, polyanhydrides, polyamides, and polyurethanes. In certain embodiments, the substance comprises a tissue inhibitor, such as a metalloproteinase (e.g., metalloproteinase 1).

[0158] The injection of certain substances (such as biopolymers and RGD-liposome biologic glue) is useful in the treatment of chronic heart failure to reinforce and strengthen the left ventricular wall. Thus, using the embodiments disclosed herein, the injection of such substances into the cardiac tissue from the pericardial space alleviates the problems and risks associated with delivery via the transthoracic approach. For instance, once the distal end of the delivery catheter is advanced to the pericardial space, as disclosed herein, a needle is extended through a lumen of the delivery catheter into the cardiac tissue and the substance is injected through the needle into the cardiac tissue.

[0159] The delivery of substances into the cardiac tissue from the pericardial space can be facilitated using a laser Doppler tip. For example, when treating ventricular wall thinning, the laser Doppler tip located in lumen 1140 of the embodiment shown in FIG. 7 can be used to measure the thickness of the left ventricular wall during the procedure (in real time) to determine the appropriate target area for injection.

[0160] Referring again to FIG. 8, although controller 1080 comprises first handle 1090 and second handle 1094, other embodiments of the controller may include different configurations. For example, instead of using handles, a controller may include any suitable torque system for controlling the steering wires of the steering wire system. Referring now to FIG. 10, there is shown a portion of a steering wire system 1170 having steering wire 1180, steering wire 1190, and controller 1200. Controller 1200 comprises a torque system 1210 having a first rotatable spool 1220, which is capable of collecting and dispensing steering wire 1180 upon rotation. For example, when first rotatable spool 1220 rotates in a certain direction, steering wire 1180 is collected onto spool 1220, thereby tightening steering wire 1180. When spool 1220 rotates in the opposite direction, steering wire 1180 is dispensed from spool 1220, thereby loosening steering wire 1180. Torque system 1210 also has a second rotatable spool 1230, which is capable of collecting and dispensing steering wire 1190 upon rotation, as described above.

[0161] Torque system 1210 further includes a first rotatable dial 1240 and a second rotatable dial 1250. First rotatable dial 1240 is attached to first rotatable spool 1220 such that rotation of first rotatable dial 1240 causes rotation of first rotatable spool 1220. Similarly, second rotatable dial 1250 is attached

to second rotatable spool 1230 such that rotation of second rotatable dial 1250 causes rotation of second rotatable spool 1230. For ease of manipulation of the catheter, torque system 1210, and specifically first and second rotatable dials 1240 and 1250, may optionally be positioned on a catheter handle (not shown) at the proximal end of tube 1010.

[0162] Steering wire system 1170 can be used to direct a delivery catheter through the body in a similar fashion as steering wire system 1140. Thus, for example, when first rotatable dial 1240 is rotated in a first direction (e.g., clockwise), steering wire 1180 is tightened and the delivery catheter is deflected in a certain direction. When first rotatable dial 1240 is rotated in the other direction (e.g., counterclockwise), steering wire 1180 is loosened and the delivery catheter straightens to its original position. When second rotatable dial 1250 is rotated in one direction (e.g., counterclockwise), steering wire 1190 is tightened and the delivery catheter is deflected in a direction opposite of the first deflection. When second rotatable dial 1250 is rotated in the other direction (e.g., clockwise), steering wire 1190 is loosened and the delivery catheter is straightened to its original position.

[0163] Certain other embodiments of steering wire system may comprise other types of torque system, so long as the torque system permits the clinician to reliably tighten and loosen the various steering wires. The magnitude of tightening and loosening of each steering wire should be controllable by the torque system.

[0164] Referring again to FIG. 11, there is shown a cross-sectional view of delivery catheter 1260. Delivery catheter 1260 includes tube 1265, a first lumen 1270, a second lumen 1280, and a steering channel 1290. Steering wires 1292, 1294, and 1296 are shown within steering channel 1290. First lumen 1270 has outlet 1275, which can be used to deliver a micro-camera system (not shown) or a laser Doppler tip 1278. Second lumen 1280 is sized to deliver a pacing lead 1300, as well as a sensing lead (not shown).

[0165] Treatment of cardiac tamponade, by the removal of a pericardial effusion, may be accomplished using an apparatus of the present disclosure as described below. A typical procedure would involve the percutaneous intravascular insertion of a portion of an apparatus into a body, which can be performed under local or general anesthesia. A portion of the apparatus may then utilize an approach described herein or otherwise known by a user of the apparatus to enter the percutaneous intravascular pericardial sac. It can be appreciated that such an apparatus may be used to access other spaces within a body to remove fluid and/or deliver a gas, liquid, and/or particulate(s) as described herein, and that such an apparatus is not limited to heart access and removal of pericardial effusions.

[0166] Exemplary embodiments of a portion of such an apparatus are shown in FIGS. 21A and 21B. As shown in FIG. 21A, a perforated drainage catheter 2100 is provided. Perforated drainage catheter 2100 comprises a tube defining at least one suction/injection aperture 2110, and as shown in the embodiment in FIG. 21A, perforated drainage catheter 2100 defines multiple suction/injection apertures 2110. Suction/injection apertures 2110 are operably connected to an internal lumen defined within perforated delivery catheter 2100. It can be appreciated that the portion of perforated drainage catheter 2100 as shown in FIGS. 21A and 21B may be coupled to one or more portions of a system for engaging a tissue as described herein. As such, one or more portions of a system



for engaging a tissue may be used to define a system for removing fluid as described herein.

[0167] It can be appreciated that the internal lumen within perforated delivery catheter 2100 may define multiple internal channels. For example, perforated delivery catheter 2100 may define two channels, one channel operably coupled to one or more suction/injection apertures 2110 to allow for a vacuum source coupled to one end of the channel to provide suction via the suction/injection apertures 2110, and one channel operably coupled to one or more other suction/injection channels to allow for the injection of gas, liquid, and/or particulate(s) to a target site.

[0168] As described in further detail below, when perforated drainage catheter 2100 enters a space in a body, for example a pericardial sac, perforated drainage catheter 2100 may be used to remove fluid by the use of suction through one or more suction/injection apertures 2110. Perforated drainage catheter 2100 may also be used to deliver gas, liquid, and/or particulate(s) to a target site through one or more suction/injection apertures 2110.

[0169] Another exemplary embodiment of a portion of a perforated drainage catheter 2100 is shown in FIG. 21B. As shown in FIG. 21B, perforated drainage catheter 2100 comprises a tube with multiple suction/injection apertures 2110. However, in this exemplary embodiment, perforated drainage catheter 2100 comprises a number of concave grooves 2120 extending a portion of a length of perforated drainage catheter 2100, whereby the suction/injection apertures 2110 are provided at the recessed portions therein. Concave grooves 2120, when positioned at least partially around the circumference of perforated drainage catheter 2100, define one or more ridges 2130 extending a portion of a length of perforated drainage catheter 2100. Said ridges 2130 of perforated drainage catheter 2100, when positioned at or near a tissue (not shown), aid to prevent a tissue from coming in direct contact with one or more suction/injection apertures 2110. For example, when perforated drainage catheter 2100 is used in a manner described herein and when a vacuum is coupled to perforated drainage catheter 2100, suction from one or more suction/injection apertures 2110 positioned within one or more concave grooves 2120 would allow for the removal of fluid present in the area of perforated drainage catheter 2100. Ridges 2130 would aid to prevent or minimize tissue adhesion and/or contact with the one or more suction/injection apertures 2110.

[0170] A procedure using perforated drainage catheter 2100 may be performed by inserting perforated drainage catheter 2100 into a pericardial sac, following the cardiac surface using, for example, fluoroscopy and/or echodoppler visualization techniques. When perforated drainage catheter 2100 is inserted into a pericardial sac, a pericardial effusion present within the pericardial sac, may be removed by, for example, gentle suction using a syringe. In one example, a 60 cc syringe may be used to remove the effusion with manual gentle suction. When the effusion has been removed, the patient's hemodynamic parameters may be monitored to determine the effectiveness of the removal of the effusion. When the pericardial sac is empty, determined by, for example, fluoroscopy or echodoppler visualization, the acute pericardial effusion catheter may be removed, or it may be used for local treatment to introduce, for example, an antibiotic, chemotherapy, or another drug as described below.

[0171] An exemplary embodiment of a portion of a perforated drainage catheter 2100 present within a pericardial sac

is shown in FIG. 22. As shown in FIG. 22, perforated drainage catheter 2100 is first inserted into the heart 2200 using one or more of the techniques and/or procedures described herein, and is placed through the right atrial appendage 2210, the visceral pericardium 2215, and into the pericardial sac 2220. The outer portion of the pericardial sac 2220 is defined by the parietal pericardium 2230. A pericardial effusion 2240 (fluid within the pericardial sac 2220) may then be removed using perforated drainage catheter 2100. When a vacuum source (not shown) is coupled to the proximal end of a portion of a system for removing fluid (comprising, in part, perforated drainage catheter 2100 and one or more other components of a system for engaging a tissue as described herein), the introduction of a vacuum to perforated drainage catheter 2100 allows the pericardial effusion 2240 (the fluid) to be withdrawn from the pericardial sac 2220 into one or more suction/injection apertures 2110 defined along a length of suction/injection apertures 2110.

[0172] When perforated drainage catheter 2100 is used to remove some or all of a pericardial effusion (or other fluid present within a space within a body), it may also be used to deliver a gas, liquid, and/or particulate(s) at or near the space where the fluid was removed. For example, the use of perforated drainage catheter 2100 to remove a pericardial effusion may increase the risk of infection. As such, perforated drainage catheter 2100 may be used to rinse the pericardial sac (or other space present within a body) with water and/or any number of beneficial solutions, and may also be used to deliver one or more antibiotics to provide an effective systemic antibiotic therapy for the patient. While the intrapericardial instillation of antibiotics (e.g., gentamycin) is useful, it is typically not sufficient by itself, and as such, it may be combined with general antibiotics treatment for a more effective treatment.

[0173] An exemplary embodiment of a system for engaging a tissue of the present disclosure is shown in FIG. 23. As shown in FIG. 23, system 2500 comprises an engagement catheter 1810 comprising a proximal end 710, a distal end 1820, and first and second lumens 730, 740 (as shown in FIG. 5D) extending between the proximal end 710 and the distal end 1820. Engagement catheter 1810, in at least one embodiment, comprises a skirt 1830 operatively connected to engagement catheter 1810 at or near the distal end 1820 of engagement catheter 1810. In such an exemplary embodiment, skirt 1830 comprises a proximal end 1833 having a circumference substantially similar to an outer circumference of engagement catheter 1810 and a distal end 1837 having a circumference larger than the outer circumference of the engagement catheter 1810.

[0174] As shown in FIG. 23, and in at least one embodiment of a system 2500, system 2500 comprises an inducer sheath 2510 having a proximal portion 2513, a distal portion 2517, a lumen 2515 extending therethrough, and an inflatable balloon 2520 at or near the distal portion 2517 of the inducer sheath 2510, wherein inducer sheath 2510 is configured so that it is capable of insertion into the second lumen 740 of the engagement catheter 1810. System 2500, in at least one embodiment, further comprises a dilator 2530 comprising a tapered tip 2540 at a distal end 2547 and a hollow channel 2550 extending therethrough, wherein dilator 2530 is sized and shaped for insertion into the lumen 2515 of the inducer sheath 2510.

[0175] A vacuum port, such as vacuum port 770 or vacuum ports 1870 previously disclosed herein, may be located at or near the proximal end 710 of engagement catheter 1810 and

operatively connected to lumen 730 of engagement catheter 1810, and may be capable of operative connection to a vacuum source (not shown) to introduce a vacuum/suction as previously disclosed herein. In addition, lumen 730 of engagement catheter 1810 may include a suction port, such as suction ports 95, 780, and/or 1765 previously disclosed herein and located at or near the distal end 1820 of engagement catheter 1810, wherein the suction port(s) is/are configured to allow the distal end 1837 of skirt 1830 to removably engage a surface of a bodily tissue 1850 such that skirt 1830 is capable of forming a reversible seal with the surface of tissue 1850 when a vacuum source is operatively attached to the vacuum port.

[0176] In various embodiments, system 2500 is capable of enlarging a pericardial space between the targeted tissue and a pericardial sac that surrounds the heart by retracting the targeted tissue away from the pericardial sac.

[0177] In at least one exemplary embodiment, and as shown in FIG. 23, system 2500 further comprises a needle device (such as a needle 40, 890, or 1890 as disclosed herein) having a needle tip 2560, wherein the needle device is capable of insertion into the hollow channel 2550 of dilator 2530, and wherein needle tip 2560 is capable of puncturing a tissue 1850 positioned at or near the distal end 2547 of dilator 2530.

[0178] In at least one exemplary embodiment, and as shown in FIG. 24, system 2500 further comprises a guide wire 1050 capable of insertion into the hollow channel 2550 of dilator 2530, wherein guide wire 1050 is further capable of insertion into a pericardial space of a pericardial sac positioned at or near the distal end 2547 of dilator 2530. In various embodiments, and as shown in FIG. 23, needle 1890 defines a needle lumen 2570 therethrough, wherein needle lumen 2570 is sized and shaped to receive a guide wire 1050 therethrough. Furthermore, and in at least one embodiment, system 2500 may further comprise a lead 1900, such as shown in FIG. 19, capable of insertion into the hollow channel 2550 of dilator 2530, wherein lead 1900 is further capable of insertion into a pericardial space of a pericardial sac positioned at or near the distal end 2547 of dilator 2530.

[0179] In various embodiment, inducer sheath 2510 may be comprised of or coated with Teflon and/or another material so that inducer sheath may slidably engage engagement catheter 1810 and so that dilator 2530 may slidably engage inducer sheath 2510. In at least one embodiment, inducer sheath 2510 has a wall thickness from about 0.2 mm to about 0.3 mm, whereby the relatively thin thickness improves sheath-to-dilator transition and assuring less puncture resistance. In various embodiments, inducer sheath 2510 has a length of no more than about 5 mm to about 6 mm of a length of engagement catheter 2510. To prevent unintentional advancement and/or retraction of inducer sheath 2510 within engagement catheter 1810, the proximal portion 2513 of inducer sheath 2510 is affixed to the proximal end 710 of engagement catheter 1810.

[0180] In at least one embodiment, inflatable balloon 2520 is comprised of a radiopaque material so that inflatable balloon 2520 appears under fluoroscopy and/or another system capable of visualizing a radiopaque material within a mammalian body. In various embodiments, the radiopaque material comprises a polyamide elastomer and tungsten.

[0181] As shown in FIGS. 23-25, an exemplary dilator 2530 comprises a tapered tip 2540 to facilitate insertion of dilator 2530 into a tissue aperture. In at least one embodiment, the tapered tip 2540 of dilator 2530 has a conical shape. In

various embodiments, dilator 2530 is comprised of polyethylene, and/or the tapered tip 2540 is comprised of polyurethane.

[0182] In at least one embodiment, and as shown in FIG. 24, dilator 2530 further comprises a dilator lock 2580 capable of preventing dilator 2530 from movement within inducer sheath 2510 after dilator 2530 is inserted into the lumen 2515 of inducer sheath 2510 and the dilator lock 2580 is locked.

[0183] In FIGS. 23 and 24, balloon 2520 is shown in a deflated state, while in FIG. 25, balloon 2520 is shown in an inflated state. Inflation of balloon 2520 and operative engagement using skirt 1830 secures various components of systems 2500 in place during procedures within a body using said systems 2500.

[0184] At least another embodiment of a system for engaging a tissue of the present disclosure is shown in FIG. 27. As shown in FIG. 27, an exemplary system 2500 comprises an engagement catheter 1810 comprising a proximal end 710, a distal end 1820, and first and second lumens 730, 740 (as shown in FIG. 5D) extending between the proximal end 710 and the distal end 1820. Engagement catheter 1810, in at least one embodiment, comprises a skirt 1830 operatively connected to engagement catheter 1810 at or near the distal end 1820 of engagement catheter 1810. In such an exemplary embodiment, skirt 1830 comprises a proximal end 1833 having a circumference substantially similar to an outer circumference of engagement catheter 1810 and a distal end 1837 having a circumference larger than the outer circumference of the engagement catheter 1810.

[0185] As shown in FIG. 27, and in at least one embodiment of a system 2500, system 2500 comprises an inducer sheath 2510 having a proximal portion 2513, a distal portion 2517, and a lumen 2515 extending therethrough, wherein inducer sheath 2510 is configured so that it is capable of insertion into the second lumen 740 of the engagement catheter 1810. System 2500, in at least one embodiment and as shown in FIG. 27, further comprises a dilator 2530 comprising a tapered tip 2540 at a distal end 2547 and a hollow channel 2550 extending therethrough, wherein dilator 2530 is sized and shaped for insertion into the lumen 2515 of the inducer sheath 2510. Various additional components or features, such as vacuum ports 770/1870, suction ports 95/780/1765, a needle 40/890/1890 having a needle tip 2560, etc., as described herein with respect to various system 2500 embodiments.

[0186] System 2500 may further comprise one or more elements and/or features of various other devices and/or systems of the present disclosure. For example, skirt 1830 may comprise a deformable configuration as previously described herein, wherein the deformable configuration of skirt 1830 is capable of expanding to an expanded configuration. Furthermore, system 2500 may further comprise a sleeve 1800, as shown in FIG. 16A, comprising a proximal end, a distal end, and a lumen extending between the proximal end and the distal end, wherein sleeve 1800 is positioned around engagement catheter 1810 to slidably engage the engagement catheter 1810.

[0187] In various embodiments, and as described herein in further detail, system 2500 (or portions thereof) can be used to engage and puncture an atrial wall (an exemplary tissue) to provide access to the pericardial space surrounding the heart.

[0188] FIG. 26 shows steps of an exemplary method of engaging a tissue to access a space adjacent thereto of the present disclosure. As shown in FIG. 26, an exemplary method 2600 comprises the step of introducing a system into

a mammalian body so that at least part of the system is adjacent to a targeted tissue (an exemplary introduction step 2610). Introduction step 2610 may be performed using an exemplary system 2500 of the present disclosure, such as, for example, a system 2500 comprising (i) an engagement catheter 1810 having a skirt 1830 coupled thereto, (ii) an inducer sheath 2510 positioned within a lumen 740 of engagement catheter 1810 and having a balloon 2520 coupled thereto, (iii) a dilator 2530 positioned within a lumen 2515 of inducer sheath 2510, and (iv) a needle 1890 positioned within a lumen 2550 of dilator 2530.

[0189] Method 2600, in at least one embodiment and as shown in FIG. 26, may further comprise the steps of engaging the targeted tissue using skirt 1830 of engagement catheter 1810 by applying a vacuum to the engagement catheter 1810 (an exemplary tissue engagement step 2620), and piercing the targeted tissue using needle 1890 to create a tissue aperture (an exemplary piercing step 2630). Tissue engagement step 2620 may include, but is not limited to, engagement of an atrial wall to ultimately provide access to a pericardial space through an atrial aperture (as provided in further detail herein), and engagement of an atrial septum to ultimately provide access to a left atrium through an atrial septum aperture, and or various other tissue engagements and/or access that may be possible using various embodiments of systems 2500 of the present disclosure.

[0190] Method 2600, in various embodiments, further comprises the steps of advancing inducer sheath 2510 and dilator 2530 into the tissue aperture so that balloon 2520 is positioned within a space behind the targeted tissue (an exemplary advancement step 2640), and inflating balloon 2520 to reversibly secure inducer sheath 2510 to the targeted tissue (an exemplary balloon inflation step 2650). In at least one embodiment, advancement step 2640 further comprises withdrawal of needle 1890 from at least part of the lumen 2550 of dilator 2530. Needle withdrawal may be performed while dilator 2530 and inducer sheath 2510 are advanced into the tissue aperture or after advancement is completed. Advancement of dilator 2530 and inducer sheath 2510, in at least one embodiment, is only from about 4 mm to about 5 mm into the space behind the targeted tissue. Various embodiments of method 2600 may include procedures performed through the left atrial cavity (including, but not limited to, lead delivery, use of an ablation catheter, internal occlusion of the left atrial appendage, etc), as the atrial septum can be held by device 2500 using skirt 1830 and/or balloon 2520, as applicable with various embodiments of systems 2500.

[0191] In addition to the foregoing, and in at least one embodiment, method 2600 may further comprise the steps of removing dilator 2530 from the inducer sheath 2510 (an exemplary dilator removal step 2660, such as removal of dilator 2530 in the direction of arrow A shown in FIG. 25), and performing a procedure within the body (an exemplary procedure performance step 2670). Procedure performance step 2670, in various embodiments, may include procedures involving the introduction and/or removal of a substance into the space behind the tissue (including drainage, for example), and/or the introduction of a device into the space, such as a lead, a vacuum catheter, and/or any number of devices capable of insertion into the body through the lumen 2515 of the inducer sheath. After completion of various procedures, balloon 2520 may be deflated so that inducer sheath 2510 may be withdrawn, and vacuum may be stopped so that skirt 1830

disengages the targeted tissue to allow withdrawal of engagement catheter 1810 from the body.

[0192] FIG. 28 shows steps of an exemplary method of engaging a tissue to access a space adjacent thereto of the present disclosure using a system 2500 either without a balloon 2520 using a system 2500 with balloon 2520 but not inflating balloon 2520. In such a method 2600, introduction step 2610, tissue engagement step 2620, and piercing step 2630 may all be performed as described above. An exemplary advancement step 2640 may then be performed so that a portion of inducer sheath 2510 and or dilator 2530 may be advanced through the aperture from piercing step 2630. In an exemplary embodiment, advancement step 2640 further comprises withdrawal of needle 1890 from at least part of the lumen 2550 of dilator 2530. Needle withdrawal may be performed while dilator 2530 and inducer sheath 2510 are advanced into the tissue aperture or after advancement is completed. In addition to the foregoing, and in at least one embodiment as shown in FIG. 28, method 2600 may further comprise the steps of removing dilator 2530 from the inducer sheath 2510 (an exemplary dilator removal step 2660, such as removal of dilator 2530 in the direction of arrow A shown in FIG. 25), and performing a procedure within the body (an exemplary procedure performance step 2670). Procedure performance step 2670, in various embodiments, may include procedures involving the introduction and/or removal of a substance into the space behind the tissue (including drainage, for example), and/or the introduction of a device into the space, such as a lead, a vacuum catheter, and/or any number of devices capable of insertion into the body through the lumen 2515 of the inducer sheath.

[0193] FIGS. 29A and 29B show portions of exemplary systems 2500 of the present disclosure positioned within a heart for transeptal atrial engagement and puncture. As shown in FIGS. 29, portions of systems 2500 are positioned into the inferior vena cava 2900 of a heart 2200 so that the distal end of system 2500 is positioned at or near the atrial septum 2910. Systems 2500, in at least the exemplary embodiments shown in FIGS. 29A and 29B, comprise a sleeve 1800 positioned around at least part of engagement catheter 1810. Engage of atrial septum 2910 can occur by way of the application of suction so that a skirt 1830 positioned at or near the end of engagement catheter 1830 can reversibly engage atrial septum 2910. The atrial septum 2910 may then be punctured, as previously described herein, and portions of system 2500 may then advance into the left atrium 2920. As shown in FIG. 29A, a balloon 2520 of system 2500 may be inflated within the left atrium 2920 to further secure portions of system 2500 in place. Embodiments of system 2500 without balloon 2520, such as shown in FIG. 29B, would be reversibly secured to the atrial septum 2910 using skirt 1830. In addition, and as shown in FIG. 29B, a guide wire 1050 may be advanced into the left atrium 2920 to facilitate further procedures as described in detail herein.

[0194] An exemplary embodiment of a system for engaging a tissue of the present disclosure is shown in FIGS. 30 through 38. As shown in FIG. 30, system 2500 comprises an engagement catheter 1810 comprising a proximal end 710, a distal end 1820, and first and second lumens 730, 740 (as shown in FIG. 5D) extending between the proximal end 710 and the distal end 1820. Engagement catheter 1810, in at least one embodiment, comprises a skirt 1830 operatively connected to engagement catheter 1810 at or near the distal end 1820 of engagement catheter 1810. In such an exemplary

embodiment, skirt **1830** comprises a proximal end **1833** having a circumference substantially similar to an outer circumference of engagement catheter **1810** and a distal end **1837** having a circumference larger than the outer circumference of the engagement catheter **1810**.

[0195] As shown in FIG. **30**, and in at least one embodiment of a system **2500**, system **2500** comprises an inducer sheath **2510** having a proximal portion **2513**, a distal portion **2517**, a lumen **2515** extending therethrough, and an inflatable balloon **2520** at or near the distal portion **2517** of the inducer sheath **2510**, wherein inducer sheath **2510** is configured so that it is capable of insertion into the second lumen **740** of the engagement catheter **1810**. System **2500**, in at least one embodiment, further comprises a dilator **3030** comprising a tapered tip **3040** at a distal end **3047** and a first channel **3050** and second channel **3060** extending therethrough, wherein dilator **3030** is sized and shaped for insertion into the lumen **2515** of the inducer sheath **2510**. In at least one embodiment, dilator **3030** may be comprised of polyurethane or other medically appropriate substitutes.

[0196] A vacuum port, such as vacuum port **770** or vacuum ports **1870** previously disclosed herein, may be located at or near the proximal end **710** of engagement catheter **1810** and operatively connected to second lumen **740** of engagement catheter **1810**, and may be capable of operative connection to a vacuum source (not shown) to introduce a vacuum/suction as previously disclosed herein. In addition, lumen **730** of engagement catheter **1810** may include a suction port, such as suction ports **95**, **780**, and/or **1765** previously disclosed herein and located at or near the distal end **1820** of engagement catheter **1810**, wherein the suction port(s) is/are configured to allow the distal end **1837** of skirt **1830** to removably engage a surface of a bodily tissue **1850** such that skirt **1830** is capable of forming a reversible seal with the surface of tissue **1850** when a vacuum source is operatively attached to the vacuum port.

[0197] In various embodiments, system **2500** is capable of enlarging a pericardial space between the targeted tissue and a pericardial sac that surrounds the heart by retracting the targeted tissue away from the pericardial sac.

[0198] In at least one exemplary embodiment, and as shown in FIG. **30**, system **2500** further comprises a needle device (such as a needle **40**, **890**, or **1890** as disclosed herein) having a needle tip **2560**, wherein the needle device is capable of insertion into the first channel **3050** of dilator **3030**, and wherein needle tip **2560** is capable of puncturing a tissue **1850** positioned at or near the distal end **2547** of dilator **3030**.

[0199] In at least one exemplary embodiment of system **2500**, and as shown in at least FIGS. **30** and **37**, the second channel **3060** of dilator **3030** is sized and shaped to allow passage of at least a portion of a catheter therethrough. Further, dilator **3030** may further comprise a third channel **3070**, as shown in FIG. **30**, that is sized and shaped to allow passage of at least a portion of a catheter therethrough. Dilator **3030**, in at least one embodiment, may also comprise a separation member **3080** extending therethrough, as shown in FIG. **33**, and separating the first channel **3050**, second channel **3060**, and third channel **3070** of dilator **3030**. Separation member **3080** may in some exemplary embodiments be removable from dilator **3030**. Upon removal of separation member **3080**, first channel **3050**, second channel **3060**, and third channel **3070** may merge into a central channel **3090** as shown in FIG. **40**.

[0200] In at least one exemplary embodiment, and as shown in FIGS. **32** and **34**, system **2500** further comprises a blocking member **3062** configured for insertion into the second channel **3060** of dilator **3030** so as to occlude second channel **3060**. Further, in an exemplary embodiment, blocking member **3062** may be configured for insertion into the second channel **3060** and third channel **3070** of dilator **3030** so as to occlude second channel **3060** and third channel **3070**.

[0201] In at least one exemplary embodiment, and as shown in FIG. **38**, system **2500** further comprises a visualization device **3100** configured for insertion into the first channel **3050** of dilator **3030**, wherein the visualization device **3100** is operable to gather location information. Such location information, in at least one exemplary embodiment, may be any spatial cue which allows an operator to determine the location of at least a portion of system **2500**. In an exemplary embodiment, visualization device **3100** may consist of one or more of an endocardial visualization device (such as a 7 French Endocardial Visualization Catheter (adapted to system **2500**), Acumen Medical, Sunnyvale, Calif.) an endoscope, and a catheter.

[0202] In at least one exemplary embodiment, and as shown in FIG. **31**, system **2500** further comprises a guide wire **1050** capable of insertion into the first channel **3050** of dilator **3030**, wherein guide wire **1050** is further capable of insertion into a pericardial space of a pericardial sac positioned at or near the distal end **3047** of dilator **3030**. In various embodiments, and as shown in FIG. **30**, needle **1890** defines a needle lumen **2570** therethrough, wherein needle lumen **2570** is sized and shaped to receive a guide wire **1050** therethrough. Furthermore, and in at least one embodiment, system **2500** may further comprise a lead **1900**, such as shown in FIG. **19**, capable of insertion into the first channel **3050** of dilator **3030**, wherein lead **1900** is further capable of insertion into a pericardial space of a pericardial sac positioned at or near the distal end **3047** of dilator **3030**.

[0203] In various embodiment, inducer sheath **2510** may be comprised of or coated with Teflon and/or another material so that inducer sheath may slidably engage engagement catheter **1810** and so that dilator **3030** may slidably engage inducer sheath **2510**. In at least one embodiment, inducer sheath **2510** has a wall thickness from about 0.2 mm to about 0.3 mm, whereby the relatively thin thickness improves sheath-to-dilator transition and assuring less puncture resistance. In various embodiments, inducer sheath **2510** has a length of within about 5 mm to about 6 mm of the length of engagement catheter **2510**. To prevent unintentional advancement and/or retraction of inducer sheath **2510** within engagement catheter **1810**, and in at least one exemplary embodiment, the proximal portion **2513** of inducer sheath **2510** is affixed to the proximal end **710** of engagement catheter **1810**.

[0204] In at least one embodiment, inflatable balloon **2520** is comprised of a radiopaque material so that inflatable balloon **2520** appears under fluoroscopy and/or another system capable of visualizing a radiopaque material within a mammalian body. In various embodiments, the radiopaque material comprises a polyamide elastomer and tungsten.

[0205] As shown in FIGS. **30** and **31**, an exemplary dilator **3030** comprises a tapered tip **3040** to facilitate insertion of dilator **3030** into a tissue aperture. In at least one embodiment, the tapered tip **3040** of dilator **3030** has a conical shape. In various embodiments, dilator **3030** is comprised of polyethylene, and/or the tapered tip **3040** is comprised of polyurethane.

[0206] In at least one embodiment, and as shown in FIG. 30, dilator 3030 further comprises a dilator lock 2580 capable of preventing dilator 3030 from movement within inducer sheath 2510 after dilator 3030 is inserted into the lumen 2515 of inducer sheath 2510 and the dilator lock 2580 is locked.

[0207] In FIGS. 30 and 31, balloon 2520 is shown in a deflated state, while in FIG. 36, balloon 2520 is shown in an inflated state. Inflation of balloon 2520 and operative engagement using skirt 1830 secures various components of systems 2500 in place during procedures within a body using said systems 2500.

[0208] FIG. 39 shows steps of an exemplary method of engaging a tissue to access a space adjacent thereto of the present disclosure. As shown in FIG. 39, an exemplary method 3200 comprises the step of introducing a multichannel system into a mammalian body so that at least part of the system is adjacent to a targeted tissue (an exemplary introduction step 3210). Introduction step 3210 may be performed using an exemplary system 2500 of the present disclosure, such as, for example, a system 2500 comprising (i) an engagement catheter 1810 having a skirt 1830 coupled thereto, (ii) an inducer sheath 2510 positioned within a lumen 740 of engagement catheter 1810 and having a balloon 2520 coupled thereto, (iii) a dilator 3030 positioned within a lumen 2515 of inducer sheath 2510, and (iv) a needle 1890 positioned within a lumen 3050 of dilator 3030.

[0209] Method 3200, in at least one embodiment and as shown in FIG. 33, may further comprise the steps of engaging the targeted tissue using skirt 1830 of engagement catheter 1810 by applying a vacuum to the engagement catheter 1810 (an exemplary tissue engagement step 3220), and piercing the targeted tissue using needle 1890 to create a tissue aperture (an exemplary piercing step 3230). Tissue engagement step 3220 may include, but is not limited to, engagement of an atrial wall to ultimately provide access to a pericardial space through an atrial aperture (as provided in further detail herein), and engagement of an atrial septum to ultimately provide access to the left atrium through an atrial septum aperture, and or various other tissue engagements and/or access that may be possible using various embodiments of systems 2500 of the present disclosure.

[0210] Method 3200, in various embodiments, further comprises the steps of advancing inducer sheath 2510 and dilator 3030 into the tissue aperture so that balloon 2520 is positioned within a space behind the targeted tissue (an exemplary advancement step 3240), and inserting at least part of a catheter into the space behind the targeted tissue (an exemplary inserting step 3250). The targeted tissue, in at least one embodiment, may be the atrial septum, and the advancement step 3240 may advance at least part of the inducer sheath 2510 and dilator 3030 into an atrial septum aperture and into the left atrium. Following advancement step 3240, in at least one embodiment, balloon 2520 may be inflated to reversibly secure inducer sheath 2510 to the targeted tissue (an exemplary balloon inflation step 3260). In at least one embodiment, advancement step 3240 further comprises withdrawal of needle 1890 from at least part of the lumen 2550 of dilator 3030. Needle withdrawal may be performed while dilator 3030 and inducer sheath 2510 are advanced into the tissue aperture or after advancement is completed. Advancement of dilator 3030 and inducer sheath 2510, in at least one embodiment, is only from about 4 mm to about 5 mm into the space behind the targeted tissue. Various embodiments of method 3200 may include procedures performed through the left

atrial cavity (including, but not limited to, lead delivery, use of an ablation catheter, internal occlusion of the left atrial appendage, etc), as the atrial septum can be held by device 2500 using skirt 1830 and/or balloon 2520, as applicable with various embodiments of systems 2500.

[0211] In addition to the foregoing, and in at least one embodiment, method 3200 may further comprise the steps of removing dilator 3030 from the inducer sheath 2510 (an exemplary dilator removal step 3270, such as removal of dilator 3030 in the direction of arrows shown in FIG. 34), and performing a procedure within the body (an exemplary procedure performance step 3280). Procedure performance step 3280, in various embodiments, may include procedures involving the introduction and/or removal of a substance into the space behind the tissue (including drainage, for example), and/or the introduction of a device into the space, such as a lead, a vacuum catheter, and/or any number of devices capable of insertion into the body through the lumen 2515 of the inducer sheath. After completion of various procedures, balloon 2520 may be deflated so that inducer sheath 2510 may be withdrawn, and vacuum may be stopped so that skirt 1830 disengages the targeted tissue to allow withdrawal of engagement catheter 1810 from the body.

[0212] In addition, methods to treat neoplastic pericardial effusions without tamponade may be utilized using a device, system and/or method of the present disclosure. For example, a systemic antineoplastic treatment may be performed to introduce drugs to inhibit and/or prevent the development of tumors. If a non-emergency condition exists (e.g., not a cardiac tamponade), a system and/or method of the present disclosure may be used to perform a pericardiocentesis. In addition, the present disclosure allows for the intrapericardial instillation of a cytostatic/sclerosing agent. It can be appreciated that using one or more of the devices, systems and/or methods disclosed herein, the prevention of recurrences may be achieved by intrapericardial instillation of sclerosing agents, cytotoxic agents, or immunomodulators, noting that the intrapericardial treatment may be tailored to the type of the tumor. Regarding chronic autoreactive pericardial effusions, the intrapericardial instillation of crystalloid glucocorticoids could avoid systemic side effects, while still allowing high local dose application.

[0213] A pacing lead may be placed on the external surface of the heart using an engagement catheter and a delivery catheter as disclosed herein. For example, an elongated tube of an engagement catheter is extended into a blood vessel so that the distal end of the tube is in contact with a targeted tissue on the interior of a wall of the heart. As explained above, the targeted tissue may be on the interior of the atrial wall or the atrial appendage. Suction is initiated to aspirate a portion of the targeted tissue to retract the cardiac wall away from the pericardial sac that surrounds the heart, thereby enlarging a pericardial space between the pericardial sac and the cardiac wall. A needle is then inserted through a lumen of the tube and advanced to the heart. The needle is inserted into the targeted tissue, causing a perforation of the targeted tissue. The distal end of a guide wire is inserted through the needle into the pericardial space to secure the point of entry through the cardiac wall. The needle is then withdrawn from the targeted tissue.

[0214] A delivery catheter, as described herein, is inserted into the lumen of the tube of the engagement catheter and over the guide wire. The delivery catheter may be a 14 Fr. radioopaque steering catheter. The distal end of the delivery catheter

is advanced over the guide wire through the targeted tissue into the pericardial space. Once in the pericardial space, the delivery catheter is directed using a steering wire system as disclosed herein. In addition, a micro-camera system may be extended through the lumen of the delivery catheter to assist in the direction of the delivery catheter to the desired location in the pericardial space. Micro-camera systems suitable for use with the delivery catheter are well-known in the art. Further, a laser Doppler system may be extended through the lumen of the delivery catheter to assist in the direction of the delivery catheter. The delivery catheter is positioned such that the outlet of one of the lumens of the delivery catheter is adjacent to the external surface of the heart (e.g., the external surface of an atrium or a ventricle). A pacing lead is extended through the lumen of the delivery catheter onto the external surface of the heart. The pacing lead may be attached to the external surface of the heart, for example, by screwing the lead into the cardiac tissue. In addition, the pacing lead may be placed deeper into the cardiac tissue, for example in the subendocardial tissue, by screwing the lead further into the tissue. After the lead is placed in the proper position, the delivery catheter is withdrawn from the pericardial space and the body. The guide wire is withdrawn from the pericardial space and the body, and the engagement catheter is withdrawn from the body.

**[0215]** The disclosed embodiments can be used for subendocardial, as well as epicardial, pacing. While the placement of the leads is epicardial, the leads can be configured to have a long screw-like tip that reaches near the subendocardial wall. The tip of the lead can be made to be conducting and stimulatory to provide the pacing to the subendocardial region. In general, the lead length can be selected to pace transmurally at any site through the thickness of the heart wall. Those of skill in the art can decide whether epicardial, subendocardial, or some transmural location stimulation of the muscle is best for the patient in question.

**[0216]** While various embodiments of devices and systems for transeptal atrial puncture using an engagement catheter platform and methods of using the same have been described in considerable detail herein, the embodiments are merely offered by way of non-limiting examples of the disclosure described herein. It will therefore be understood that various changes and modifications may be made, and equivalents may be substituted for elements thereof, without departing from the scope of the disclosure. Indeed, this disclosure is not intended to be exhaustive or to limit the scope of the disclosure.

**[0217]** Further, in describing representative embodiments, the disclosure may have presented a method and/or process as a particular sequence of steps. However, to the extent that the method or process does not rely on the particular order of steps set forth herein, the method or process should not be limited to the particular sequence of steps described. Other sequences of steps may be possible. Therefore, the particular order of the steps disclosed herein should not be construed as limitations of the present disclosure. In addition, disclosure directed to a method and/or process should not be limited to the performance of their steps in the order written. Such sequences may be varied and still remain within the scope of the present disclosure.

1. A multichannel system for engaging a tissue, the system comprising:

an inducer sheath having a proximal portion and a distal portion and defining a lumen extending therethrough,

- the inducer sheath configured for insertion into a first lumen of an engagement catheter; and
- a dilator defining a first channel and a second channel extending therethrough and a tapered tip at the distal end of the dilator, the dilator sized and shaped for insertion into the lumen of the inducer sheath, wherein the tapered tip is configured to facilitate insertion of the dilator into a mammalian tissue aperture, wherein the mammalian tissue aperture is created using a device positioned within the first channel or the second channel of the dilator.
  2. The system of claim 1, further comprising:
    - a needle device having a needle tip, the needle device capable of insertion into the first channel of the dilator, wherein the needle tip is capable of puncturing a tissue positioned at or near the distal end of the dilator.
    3. The system of claim 1, wherein the second channel is sized and shaped to allow passage of at least a portion of a first catheter therethrough.
    4. The system of claim 1, wherein the dilator further defines a third channel extending therethrough, the third channel sized and shaped to allow passage of at least a portion of a second catheter therethrough.
    5. The system of claim 1, further comprising:
      - a blocking member configured for insertion into the second channel of the dilator to occlude the second channel of the dilator.
      6. The system of claim 1, further comprising:
        - a visualization device configured for insertion into the first channel of the dilator, wherein the visualization device is operable to gather location information.
        7. The system of claim 1, wherein the engagement catheter further defines a second lumen and further comprises a skirt operatively connected to the distal end of the engagement catheter, the skirt comprising a proximal end having a circumference substantially similar to an outer circumference of the engagement catheter, the skirt further comprising a distal end having a circumference larger than the outer circumference of the engagement catheter; and
          - wherein the system further comprises:
            - a vacuum port located at the proximal end of the engagement catheter, the vacuum port operably connected to the second lumen of the engagement catheter and capable of operative connection to a vacuum source;
 wherein the second lumen of the engagement catheter includes a suction port located at or near the distal end of the engagement catheter, the suction port configured to allow the distal end of the skirt to removably engage a surface of a bodily tissue such that the skirt is capable of forming a reversible seal with the surface of the tissue when a vacuum source is operatively attached to the vacuum port.
            8. The system of claim 7, wherein the skirt comprises a deformable configuration, and wherein the deformable configuration of the skirt is capable of expanding to an expanded configuration.
            9. The system of claim 1, further comprising:
              - a needle defining a needle lumen therethrough, the needle lumen sized and shaped to receive a guide wire therethrough.
              10. The system of claim 1, further comprising:
                - an inflatable balloon at or near the distal portion of the inducer sheath, the inflatable balloon comprising a radiopaque material.

**11.** The system of claim 1, wherein the proximal portion of the inducer sheath is affixed to the proximal end of the engagement catheter.

**12.** The system of claim 1, wherein the tapered tip of the dilator has a conical shape.

**13.** The system of claim 1, wherein the dilator further comprises a dilator lock capable of preventing the dilator from backward movement after the dilator is inserted into the lumen of the inducer sheath and the dilator lock is locked.

**14.** A method of engaging a tissue to access a space adjacent thereto, the method comprising the steps of:

introducing a multichannel system into a mammalian body so that at least part of the system is adjacent to a targeted tissue, the system comprising:

- an engagement catheter having a skirt coupled thereto,
- an inducer sheath positioned within a lumen of the engagement catheter,
- a dilator positioned within a lumen of the inducer sheath, the dilator having a tapered tip, the tapered tip configured to facilitate insertion of the dilator into a mammalian tissue aperture,
- a needle positioned within a first channel of the dilator, and
- a catheter positioned within a second channel of the dilator;

engaging the targeted tissue using the skirt of the engagement catheter by applying a vacuum to the engagement catheter;

piercing the targeted tissue using the needle to create the tissue aperture; and

advancing at least part of the inducer sheath and at least part of the dilator into the tissue aperture and into a space behind the targeted tissue.

**15.** The method of claim 14, further comprising the step of: inserting at least a portion of the catheter into the space behind the targeted tissue.

**16.** The method of claim 14, wherein the step of advancing causes a balloon coupled to the inducer sheath to be positioned into the space behind the targeted tissue, and wherein the method further comprises the step of:

inflating the balloon to reversibly secure the inducer sheath to the targeted tissue.

**17.** The method of claim 14, further comprising the steps of:

removing the dilator from the inducer sheath; and performing a procedure, the procedure selected from the group consisting of introducing a substance into the space, removing a substance from the space, and introducing a device into the space.

performing a procedure, the procedure selected from the group consisting of introducing a substance into the space, removing a substance from the space, placing a lead within the mammalian body distal to the tissue aperture, and introducing a device into the space.

**18.** The method of claim 14, wherein the step of engaging the targeted tissue comprises engaging an atrial wall or an atrial septum, and wherein the step of advancing comprises advancing at least part of the inducer sheath and the dilator into and through an atrial wall aperture or an atrial septum aperture.

**19.** A method of engaging a tissue to access a space adjacent thereto, the method comprising the steps of:

introducing a multichannel system into a mammalian body so that at least part of the system is adjacent to a targeted tissue, the system comprising:

- an inducer sheath positioned within a lumen of an engagement catheter, and
- a dilator positioned within a lumen of the inducer sheath, the dilator having a tapered tip, the tapered tip configured to facilitate insertion of the dilator into a mammalian tissue aperture;

engaging the targeted tissue using a distal end of the engagement catheter by applying a vacuum to the engagement catheter;

piercing the targeted tissue to create the tissue aperture; and advancing at least part of the inducer sheath and at least part of the dilator into the tissue aperture and into a space behind the targeted tissue;

removing the dilator from the inducer sheath; and performing a procedure, the procedure selected from the group consisting of introducing a substance into the space, removing a substance from the space, placing a lead within the mammalian body distal to the tissue aperture, and introducing a device into the space.

**20.** The method of claim 19, wherein the step of advancing causes a balloon coupled to the inducer sheath to be positioned into the space behind the targeted tissue, and wherein the method further comprises the step of:

inflating the balloon to reversibly secure the inducer sheath to the targeted tissue.

\* \* \* \* \*