



US 20080217379A1

(19) **United States**

(12) **Patent Application Publication**
Abramovici et al.

(10) **Pub. No.: US 2008/0217379 A1**

(43) **Pub. Date: Sep. 11, 2008**

(54) **METHOD FOR COHESIVELY BONDING METAL TO A NON-METALLIC SUBSTRATE**

Publication Classification

(76) Inventors: **Eugen Abramovici**, Toronto (CA);
David E. Gevers, Lafayette, IN (US);
Lucian M. Silvian, West Lafayette, IN (US)

(51) **Int. Cl.**
B23K 31/02 (2006.01)
(52) **U.S. Cl.** **228/124.1**

(57) **ABSTRACT**

A process for cohesive bonding between a metal surface and a nonmetallic substrate is provided. The non-metallic substrate may comprise a plurality of microfilaments and/or nanofilaments dispersed into and below the surface of the substrate. The application of pressure and laterally-oriented high frequency and low amplitude vibration may allow for diffusion bonding between the metal surface and material of the nanofilaments. Another method includes discharging energy from a bank of capacitors to melt adjoining surfaces of the metal surface and nonmetallic substrate. Additionally, a cohesive bonding method may further comprise converting electrical oscillations of ultrasonic frequency into ultrasonic vibrations which are transmitted to the metal body and/or substrate for fusing the two materials together.

Correspondence Address:
BOSE MCKINNEY & EVANS LLP
2700 FIRST INDIANA PLAZA
135 NORTH PENNSYLVANIA
INDIANAPOLIS, IN 46204 (US)

(21) Appl. No.: **12/045,347**

(22) Filed: **Mar. 10, 2008**

Related U.S. Application Data

(60) Provisional application No. 60/894,213, filed on Mar. 10, 2007.

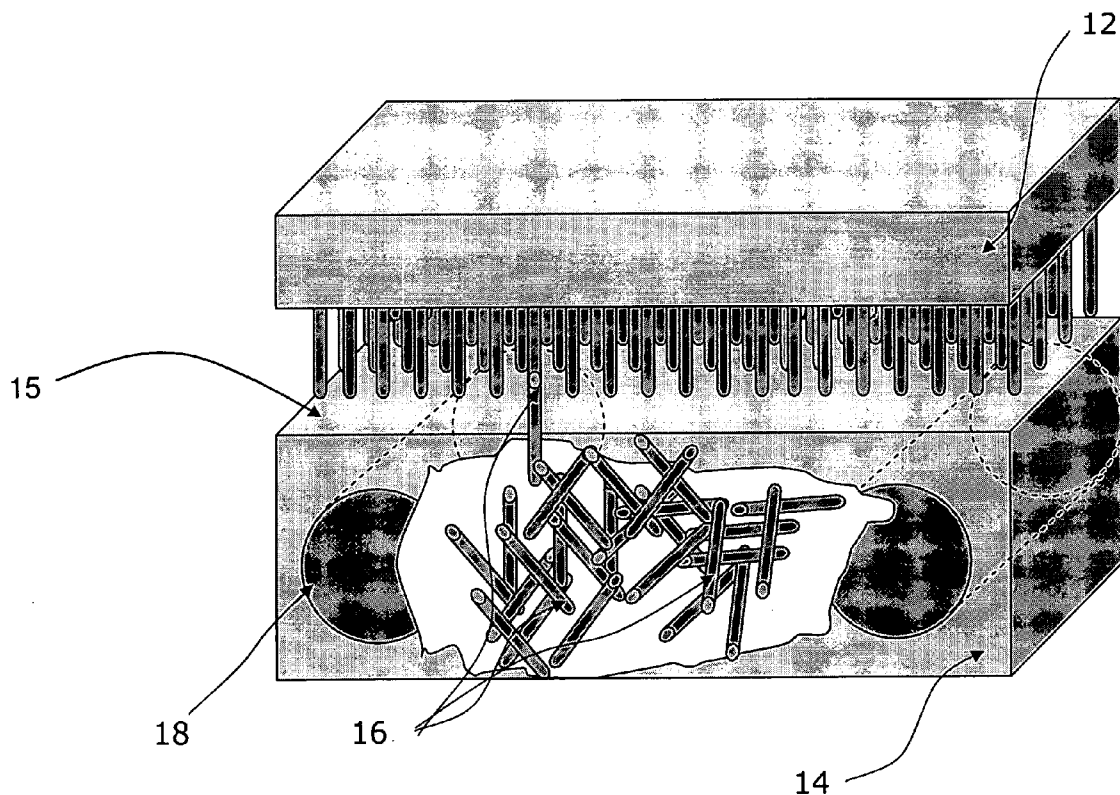

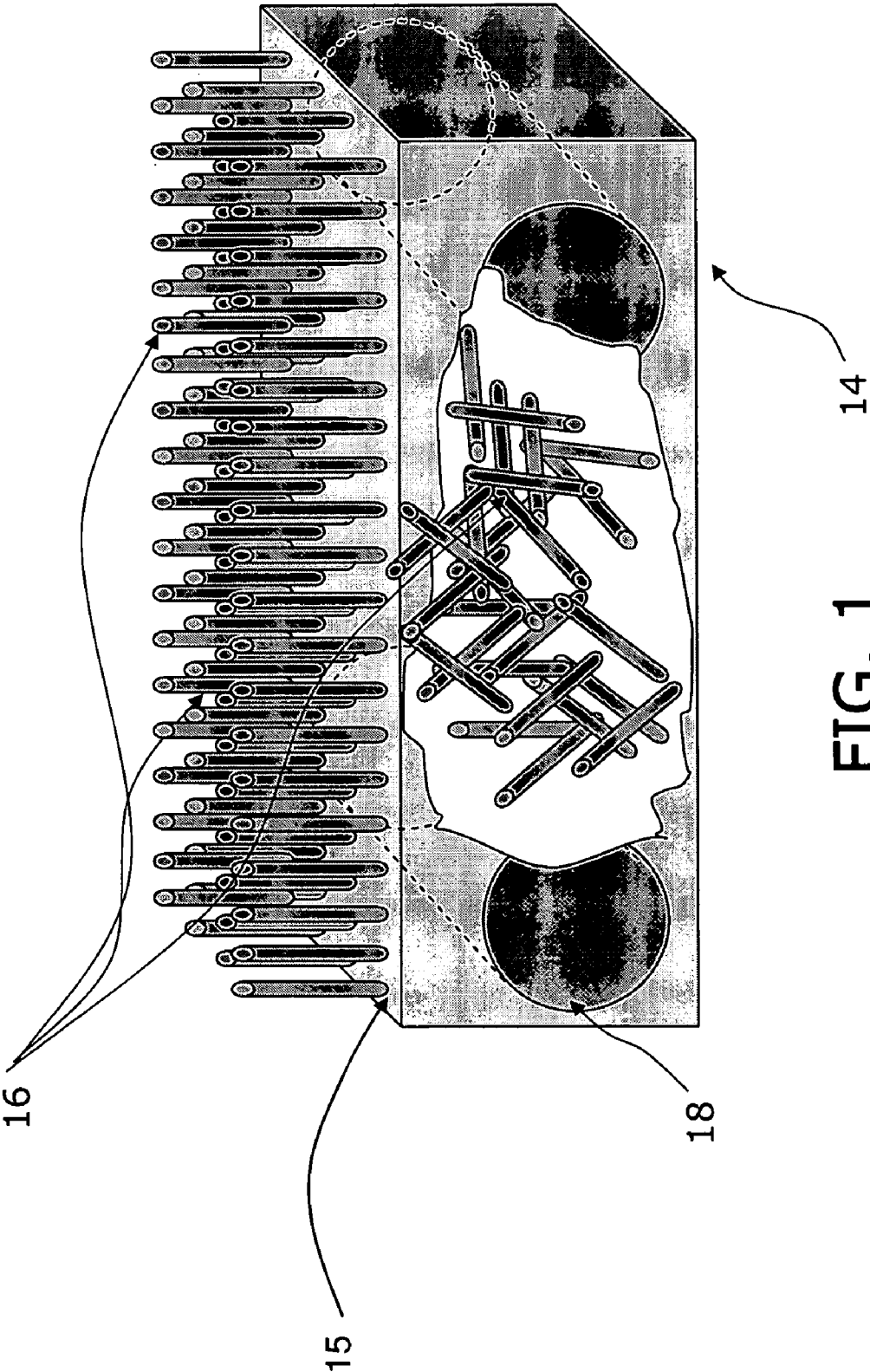

FIG. 1

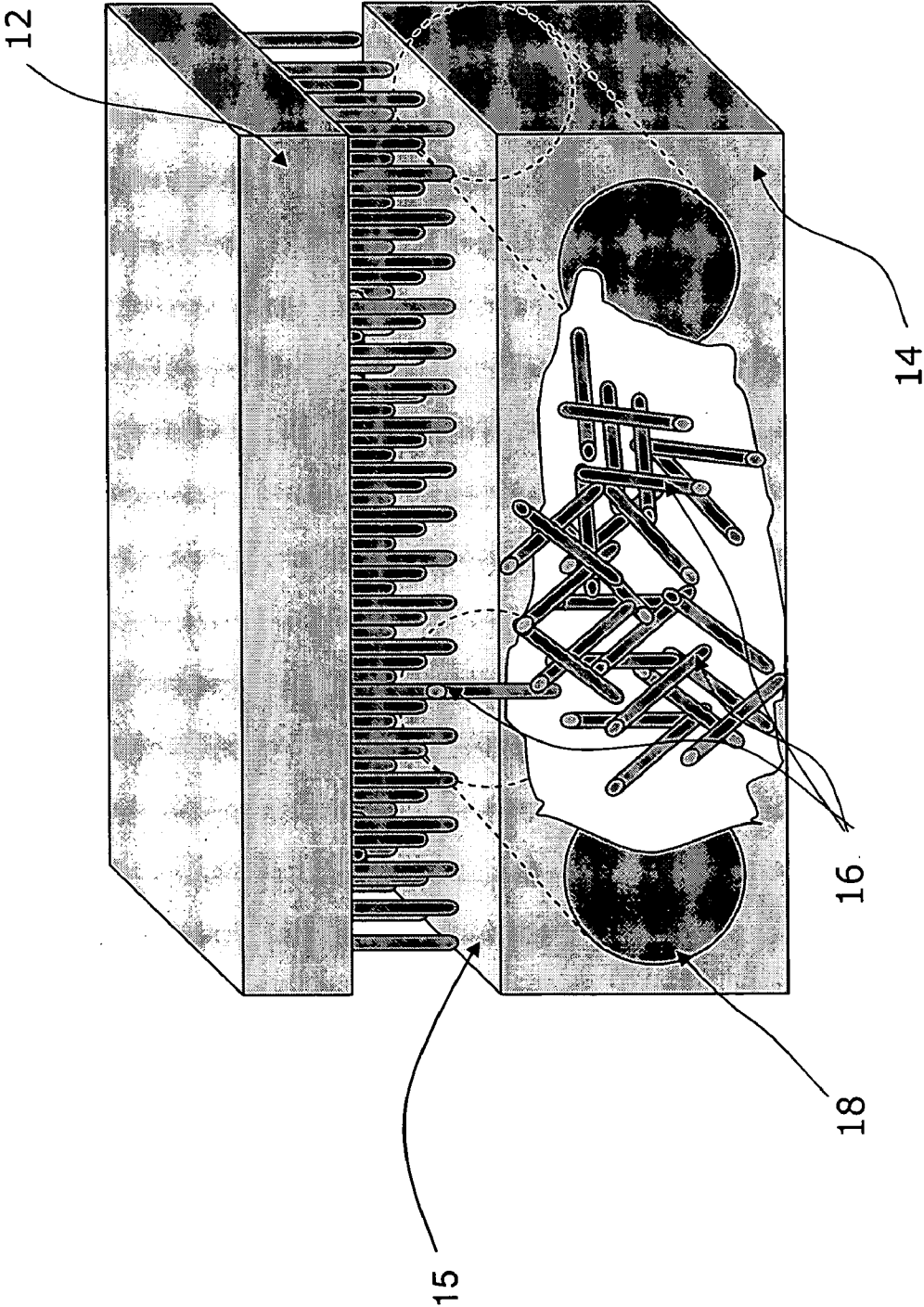

FIG. 2

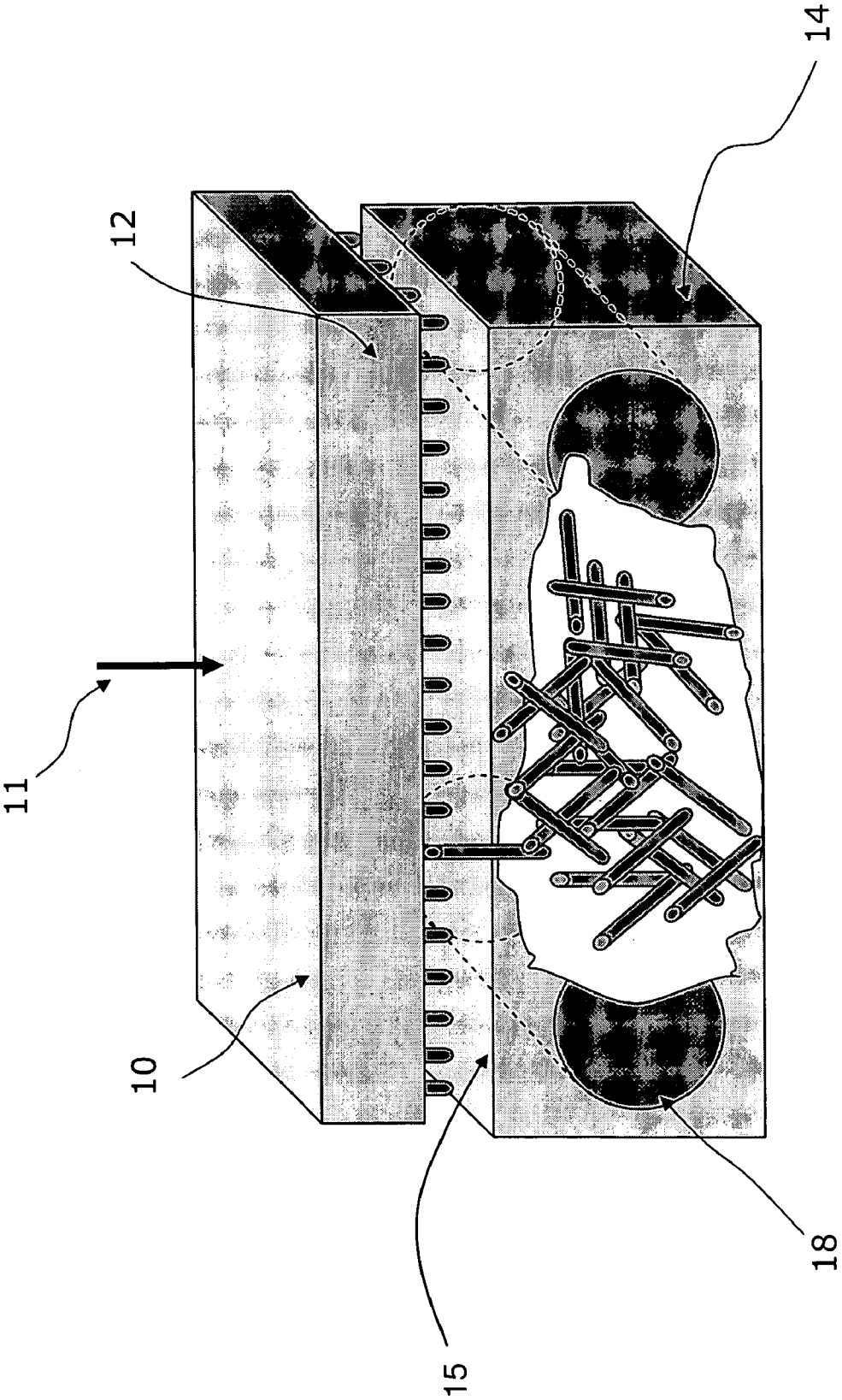

FIG. 3

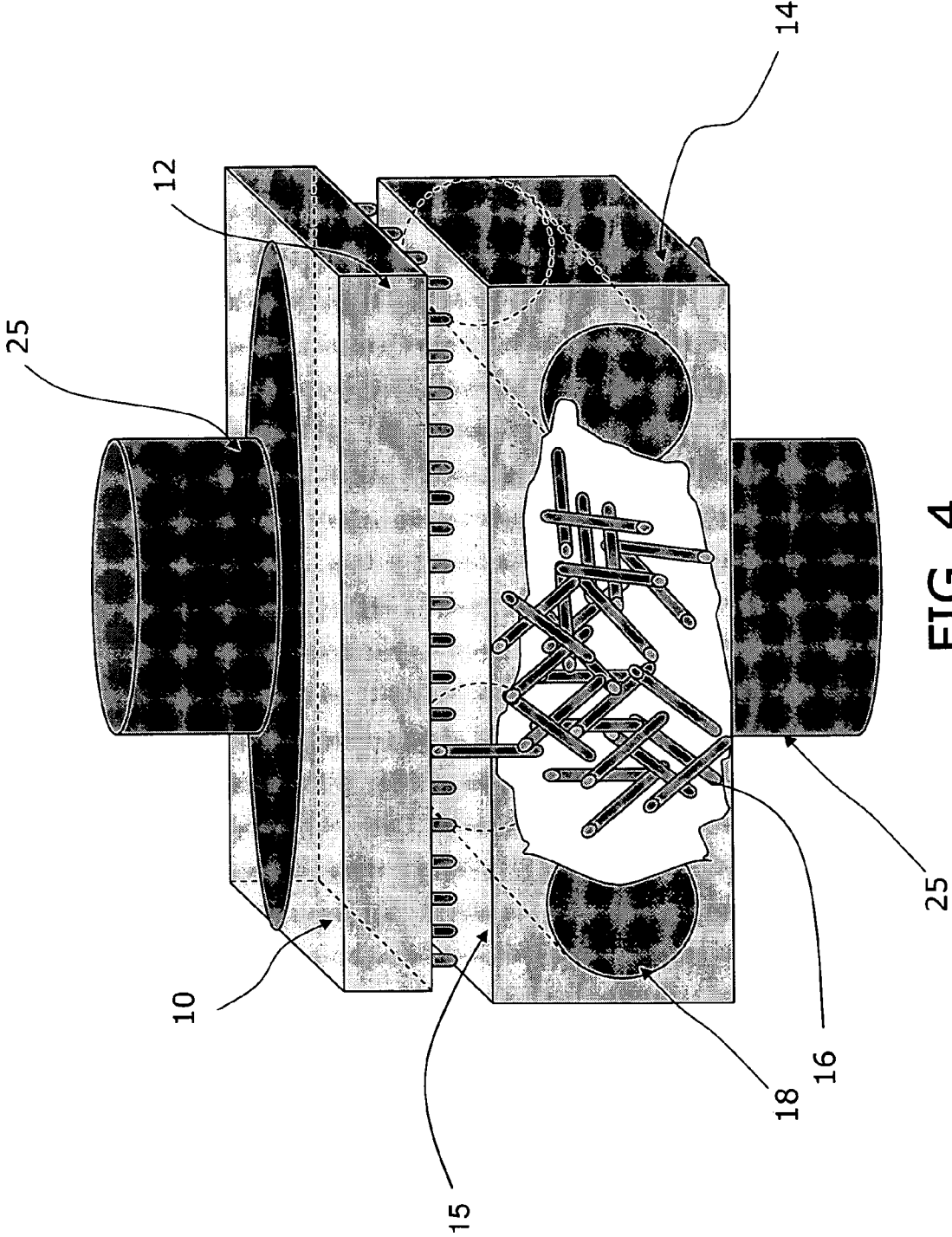

FIG. 4

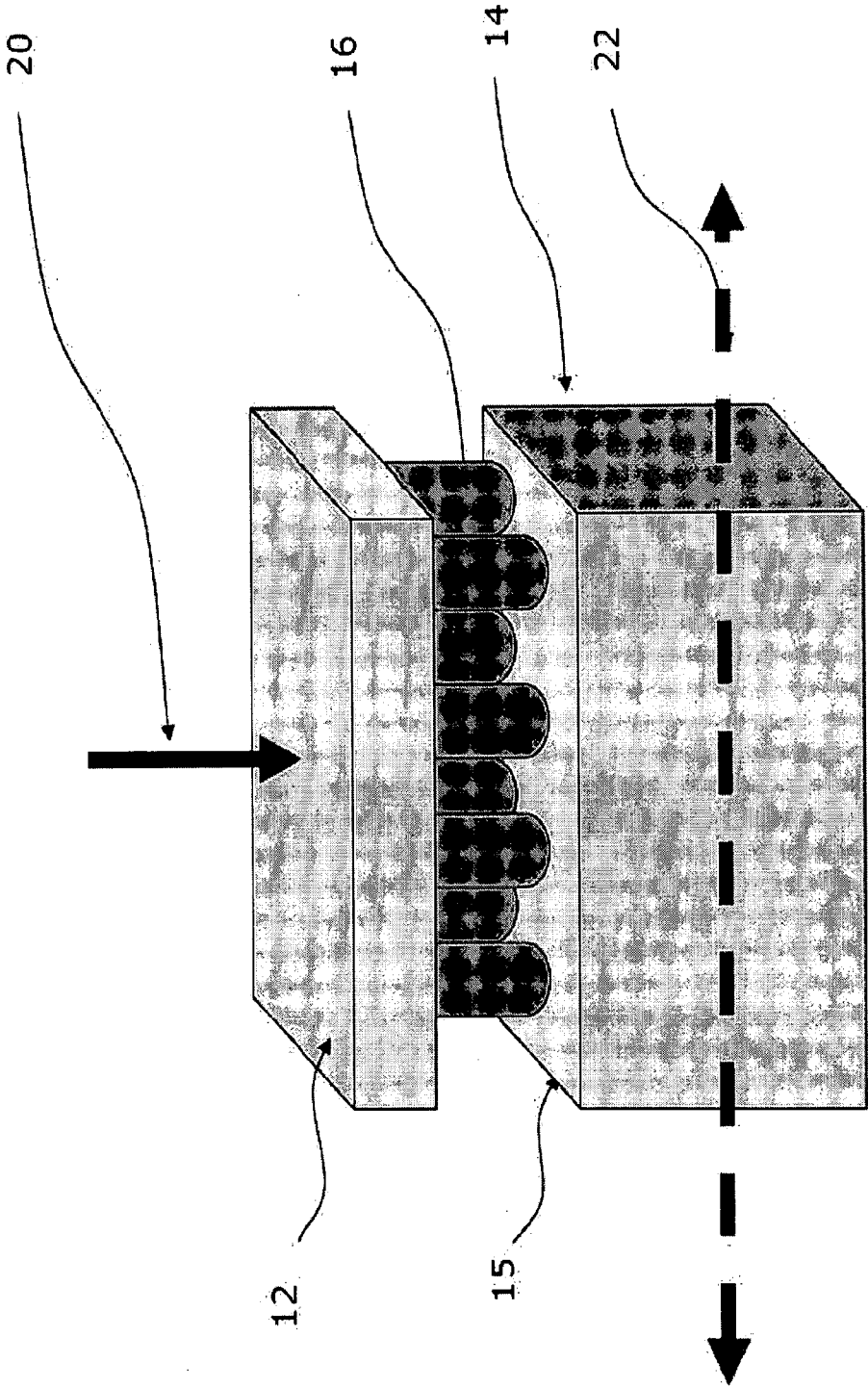

FIG. 5

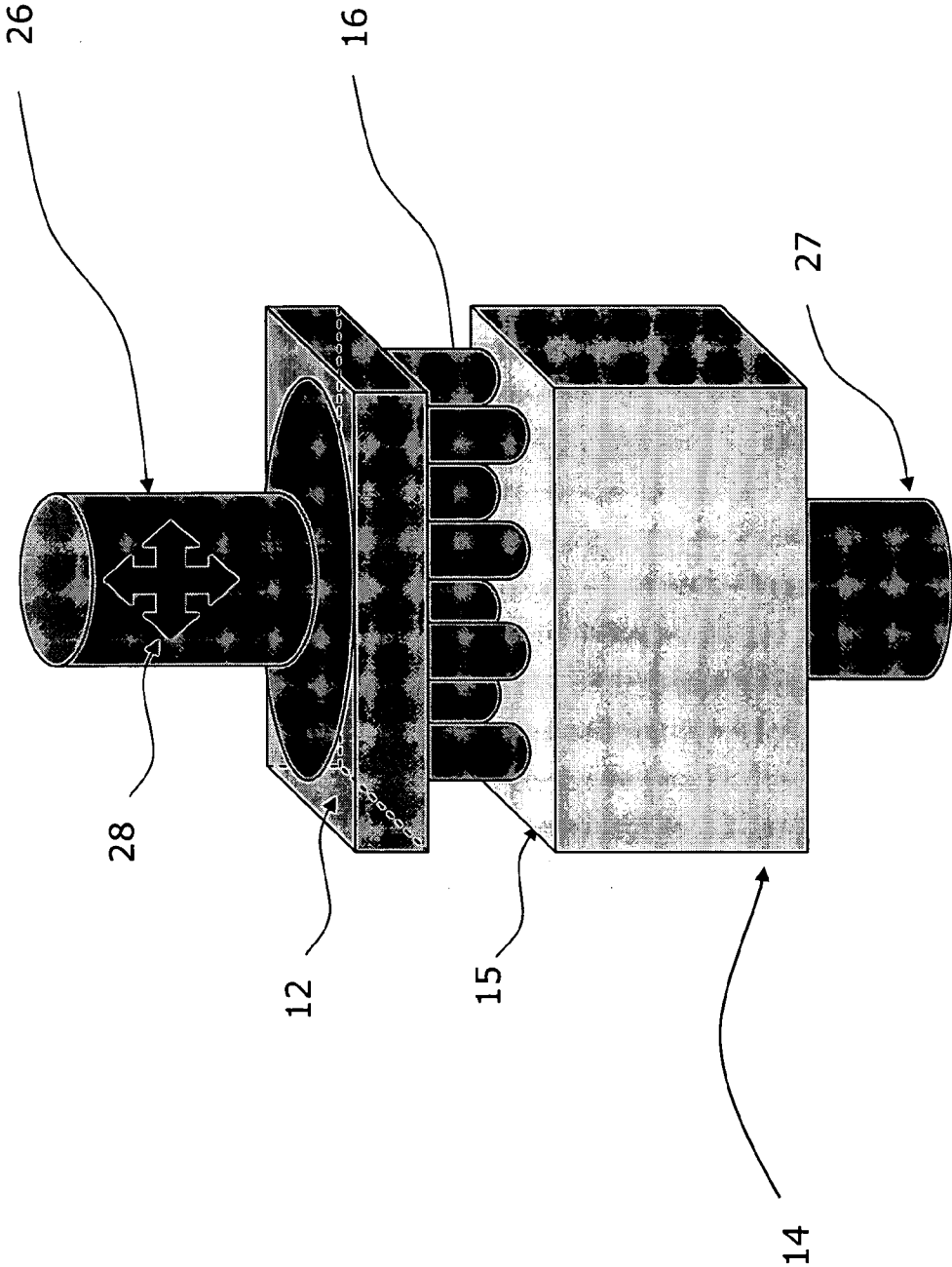

FIG. 6

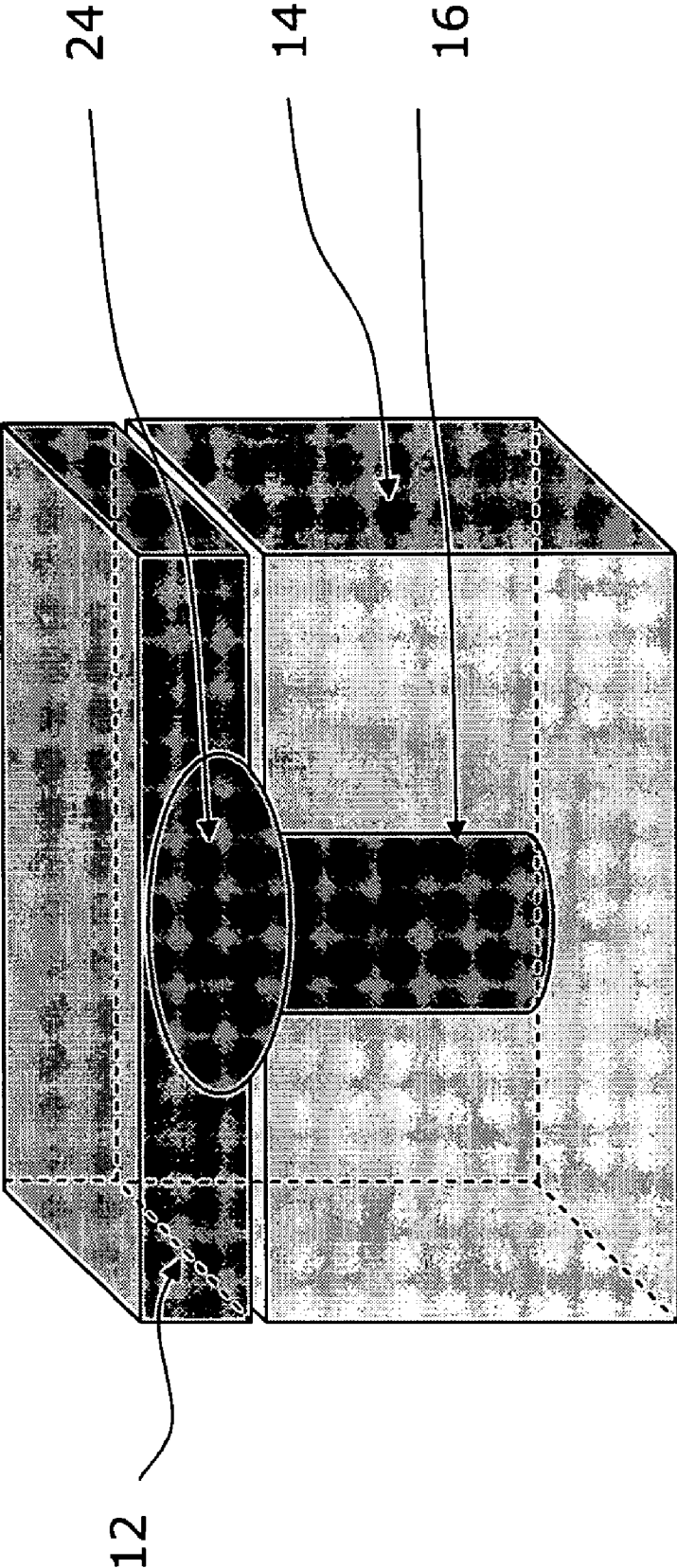

FIG. 7

METHOD FOR COHESIVELY BONDING METAL TO A NON-METALLIC SUBSTRATE

RELATED APPLICATIONS

[0001] This application claims priority to U.S. Provisional Application Ser. No. 60/894,213, filed Mar. 10, 2007, which is hereby incorporated by reference in its entirety.

BACKGROUND

[0002] The present invention relates generally to a method for cohesively bonding metal to a non-metallic substrate and more particularly, to the use of metallic micro and nano size filaments, embedded into the non-metallic material, to create cohesive bonds with the metallic material.

[0003] Non-metallic materials, and in particular composite materials such as graphite-fibers or fiberglass fibers with epoxy matrices, are notoriously difficult to attach to metallic materials. The most used methods to create such assemblies are adhesive bonding or the use of fastening devices. Both of these methods have disadvantages related to disbanding due to water infiltration and corrosion or due to the fracture of the superficial surfaces where the fastening devices are connected to the composite material.

[0004] Various methods are commonly used to attach two metal surfaces to each other. Besides fastening, welding is such a method; however, many others such as brazing, soldering, diffusion bonding and adhesive bonding are widely used in industry. All of these methods are generally dependent on a plurality of parameters including applied pressure, bonding temperature, time, and the method of heat application. The surface finish of the components can play an important role, as well. To form a cohesive bond, it is important for two, clean and flat surfaces to come into atomic contact with one another, with microasperities and surface layer contaminants being removed from the bonding faces before bonding.

[0005] Welding, in general, is making use of high temperatures to melt the two metals in contact with each other or to melt a filler material, creating a pool of common, molten alloy that when solidifies, would strongly connect the two together. On the other side, the diffusion bonding process is known to create a strong bond between two metals without melting them by using only pressure and lower temperatures, and without the introduction on any extrinsic material.

[0006] However, bonding a metal surface to a non-metallic substrate generally cannot be accomplished by any of the methods outlined above and often requires the addition of an extrinsic material, such as an adhesive. Hence, adhesive bonding or fastening methods are extensively used to connect metallic materials to non-metallic substrates.

[0007] Accordingly, it would be desirable to have a bonding method that forms a strong cohesive bond between a metal body and a non-metallic substrate.

SUMMARY OF THE INVENTION

[0008] In one aspect of the present invention there is provided a method for cohesive bonding a metal body to a substrate comprising the steps of contacting the metal body to a surface of the substrate, the substrate comprising a plurality of microfilaments or nanofilaments dispersed into or below the surface of the substrate and the metal body surface comprising microscopic asperities which contact the plurality of microfilaments or nanofilaments, applying normally-oriented pressure on the metal body and laterally-oriented high

frequency and low amplitude vibrations to the substrate and forming a cohesive bond between the metal body and the substrate.

[0009] In another aspect of the present invention there is provided a method for cohesive bonding a metal body to a substrate comprising the steps of coupling a plurality of capacitors to the metal body and the substrate, contacting the metal body to the substrate, the substrate comprising a plurality of microfilaments or nanofilaments, wherein the microfilaments or nanofilaments provide microscopic asperities on at least the substrate surface which contacts the metal body, discharging energy from the plurality of capacitors to raise the temperature of the surfaces of the metal body and the substrate which contact one another, applying pressure on the metal body or substrate and forming a cohesive bond between the metal body and the substrate.

[0010] In a further aspect of the present invention there is provided a method for cohesive bonding a metal body to a substrate comprising the steps of contacting the metal body to the substrate, the substrate comprising a plurality of microfilaments or nanofilaments, wherein the microfilaments or nanofilaments provide microscopic asperities on at least the substrate surface which contacts the metal body, positioning a sonotrode to contact the metal body, applying normally-oriented pressure on the metal body or substrate, vibrating the metal body or substrate and forming a cohesive bond between the metal body and the substrate.

[0011] These and other features, aspects and advantages of the present invention will become better understood with reference to the following drawings, description and claims.

BRIEF DESCRIPTION OF THE DRAWINGS

[0012] The above-mentioned aspects of the present invention and the manner of obtaining them will become more apparent and the invention itself will be better understood by reference to the following description of the embodiments of the invention, taken in conjunction with the accompanying drawings, wherein:

[0013] FIG. 1 is a schematic of composite material comprising a matrix and fibers having a plurality of microfilaments and/or nanofilaments embedded in the matrix;

[0014] FIG. 2 is a schematic of the composite material of FIG. 1 with a metal body to be bonded to the matrix;

[0015] FIG. 3 is a schematic of the metal body of FIG. 2 being compressed to the matrix;

[0016] FIG. 4 is a schematic of a metal body being bonded to a non-metallic substrate via capacitor-discharge bonding;

[0017] FIG. 5 is a schematic of a metal body being bonded to a non-metallic substrate via localized friction bonding;

[0018] FIG. 6 is a schematic of a metal body being bonded to a non-metallic substrate via ultrasonic welding; and

[0019] FIG. 7 is a schematic showing an enlarged view of the bond formed as the result of the method of the present invention between a metal surface and a substrate comprising microfilaments and/or nanofilaments.

[0020] Corresponding reference numerals are used to indicate corresponding parts throughout the several views.

DETAILED DESCRIPTION

[0021] The embodiments of the present invention described below are not intended to be exhaustive or to limit the invention to the precise forms disclosed in the following detailed description. Rather, the embodiments are chosen and

described so that others skilled in the art may appreciate and understand the principles and practices of the present invention.

[0022] Broadly the present invention provides methods for cohesively bonding the surface of a metal body to a non-metallic substrate which may comprise contacting a metal surface of the metal body with a surface of the substrate. The substrate may comprise a plurality of microfilaments and/or nanofilaments which may provide microscopic asperities on the surface of the substrate in contact with the metal surface. The method may further use a variety of known joining process such as: friction welding, capacitor-discharge welding, ultrasonic welding and diffusion bonding to connect the filaments with the metallic body. These methods may comprise simultaneously applying normally-oriented pressure to the metal surface and laterally-oriented high frequency and low amplitude vibrations to the substrate and forming a cohesive bond between the metal surface and the substrate. The applied loads are typically below those loads which would cause macro-deformation of the components' materials. This process, known as localized friction welding, creates localized increases of contact temperature that do not exceed 0.5-0.8 times the melting point temperature of such materials and the temperature of the materials can remain in this range for 0.004 seconds to over 3600 seconds depending upon the type of materials being bonded, the joint properties of these materials, and the heating method being used.

[0023] Other joining processes may comprise radiant heating, induction heating and direct or indirect resistance heating. For example, the diffusion bonding process may be further assisted by additionally exposing the components' materials to higher temperatures, inert gases and/or a vacuum. While not wishing to be bound by any particular theory, the cohesive bond may be formed by diffusion of the microfilament and/or nanofilament material into the metal layer, thus forming a stronger bond than one without the presence of the microfilaments and/or nanofilaments.

[0024] An exemplary embodiment of a composite material (hereinafter referred to as "substrate") is shown in FIG. 1. The substrate **14** comprises a matrix that may include fibers **18** and a plurality of microfilaments and/or nanofilaments **16** randomly oriented and embedded within the matrix. The microfilaments and/or nanofilaments **16** are metallic, but alternatively they may comprise ceramic, plastic, or any other material known to the skilled artisan. Some or all of the plurality of microfilaments and/or nanofilaments **16** may extend out of a surface **15** of the substrate **14**, whereas others may be embedded in the substrate without extending out of the substrate.

[0025] In one embodiment of the present invention, substrate **14** of FIG. 1 may be any material desired to form a bond to a metal surface **12** and which may have microfilaments and/or nanofilaments **16** dispersed therein. In general, the substrate **14** comprises non-metallic material. In one exemplary embodiment, the substrate **14** may comprise a composite material such as, but not limited to, a metal matrix composite, a ceramic composite or a polymer composite. The polymer composite may comprise unidirectional or multidirectional oriented fibers of graphite, fiberglass, aramid or a combination thereof. Substrate **14** may comprise any size or form desired. It may be preformed into a desired shape or part. Alternatively, it may be shaped or formed after bonding to the metal surface.

[0026] As described above with reference to FIG. 1, the substrate **14** may comprise a plurality of microfilaments and/or nanofilaments **16**. The plurality of microfilaments and/or nanofilaments **16** may be dispersed on and below a surface **15** (see FIG. 1) of the substrate **14**. In one exemplary embodiment, the plurality of microfilaments and/or nanofilaments **16** are introduced individually into the substrate **14** and may create an intricate network in the substrate **14**. In an alternate embodiment, the plurality of microfilaments and/or nanofilaments **16** may be introduced into the substrate **14** being physically connected to one another, forming a structure such as, but not limited to, a micrometric or nanometric sized foam. It will be appreciated that a network of microfilaments and/or nanofilaments **16** may provide firstly, a strong adhesion bond within the substrate **14** and subsequently provide the opportunity for bonding between metal surface **12** and substrate **14**.

[0027] In one embodiment of a cohesive bonding process, a metal-bonded substrate is shown in FIG. 2. In this process, a metal body **12** may be cohesively bonded to the substrate **14** via one of several bonding methods, three of which will be described below in further detail. Similar to the substrate shown in FIG. 1, the substrate **14** in FIG. 2 may comprise a plurality of randomly-oriented microfilaments and/or nanofilaments **16** and a plurality of aligned fibers **18** dispersed throughout substrate **14** and which are usually introduced as a specially fabricated cloth.

[0028] The microfilaments and/or nanofilaments **16** may form microscopic asperities on the surface **15** of the substrate **14** and may change the material characteristics of the substrate **14** at or near the surface **15**. The plurality of microfilaments and/or nanofilaments **16** may be dispersed in the substrate **14** during the manufacture of the substrate **14**. Alternately, the microfilaments and/or nanofilaments **16** may be dispersed in the substrate **14** afterwards by other methods known in the art. The plurality of microfilaments and/or nanofilaments **16** may be distributed throughout the substrate **14** to provide the optimal cohesive bond between the substrate **14** and the surface of the metal body **12**. The plurality of microfilaments and/or nanofilaments **16** may be evenly distributed throughout the substrate **14** or they may be concentrated at the surface **15** of the substrate **14** where the surface of the metal body **12** will be bonded, gradually decreasing in the substrate **14** away from the surface **15**.

[0029] In another embodiment of the present invention the microfilaments and/or nanofilaments **16** may comprise a material capable of bonding with the metal body **12**. In one exemplary embodiment, the microfilaments and/or nanofilaments **16** may comprise a metal such as, but not limited to, stainless steel or a titanium alloy. In another embodiment, the microfilaments and/or nanofilaments **16** may comprise a material capable of sustaining the bond or joint between the substrate **14** and the metal body **12** and may also have desired corrosion resistance as well as little or no adherent oxide layer.

[0030] In one embodiment in which micro or nanofilaments produced using the present state of art are embedded in the substrate **14**, those filaments **16** may have a diameter of less than 100 nm up to 1000 nm in cross-sectional dimension. In an exemplary embodiment, nanofilaments **16** produced using other, advanced technologies may be less than about 100 nm in cross-sectional dimension. It will be appreciated that the cross-sectional dimension of the nanofilaments **16** may be small enough to provide an optimal number of interactions with the metal body **12** but still retain integrity and strength.

Based on the present technology the nanofilaments **16** may have a length less than about 400 μm . The nanofilaments **16** may be made by processes known in the art such as, but not limited to, the process described in U.S. Pat. No. 6,444,256, which is herein incorporated by reference

[0031] In a different embodiment of the present invention, the surface of the metal body **12** may be the surface of a metal strip, a metal sheet, a metal plate or a metal block. It is contemplated that any metal surface found on any part or material may be bonded to the substrate **14** using the process of the present application. The metal surface **12** may comprise any metal having the desired properties for the application in which the bonded metal and composite complex **10** are to be used. By way of a non-limiting example, the metal body surface **12** may comprise stainless steel or titanium.

[0032] In FIG. 3, a method for cohesive bonding a metal surface **12** to a substrate **14** is provided. In one embodiment, pressure may be applied in a direction **11** against the metal body **12** such that the metal body **12** is compressed against the substrate **14**. The pressure can be applied uniaxially or isotatically. Uniaxial pressure generally requires lower pressure in the range of 3-10 MPa to avoid macro-deformation of the bonded materials. Additionally, this process typically requires good surface finish on the mating surfaces as the contribution to bonding provided by plastic yielding is restricted. In general, surface finishes with roughness values better than 0.4 μm RA and which are free from contaminants are advantageous for bonding purposes. As for isotatic pressure, much higher pressures such as 100-200 MPa may be possible and therefore surface finish is not as critical. For example, surface finishes of 0.8 μm or greater may be acceptable for the bonding process. An additional advantage of applying isotatic pressure is that the use of uniform gas pressurization allows complex geometries to be bonded, whereas uniaxial pressure generally can only be used for simple butt or lap joint bonding.

[0033] An exemplary method for cohesive bonding is shown in FIG. 4 known as capacitor-discharge welding. In FIG. 4, a substrate **14** is provided which includes fibers **18** and a plurality of microfilaments and/or nanofilaments **16** embedded in the substrate **14**. A metal body **12** is brought into contact with a surface of the substrate **14** such that a portion of the plurality of microfilaments and/or nanofilaments **16** found on the surface **15** of substrate **14** may contact the metal body **12**. Capacitors (not shown) are provided to be coupled to at least one of the metal body **12** and substrate **14** through contact elements **25**. Contact elements **25** may be placed onto at least one surface of the metal body **12** and/or substrate **14**. Energy stored in the capacitors at specific voltages may be released or discharged through contact elements **25** to **14** and **12**. As the energy is discharged, an instantaneous arc may be created which melts the adjoining surfaces of the metal body **12** and microfilaments and/or nanofilaments **16**. Either simultaneously or shortly thereafter, pressure may be applied to both materials such that the materials compress against one another and a cohesive bond is formed between the metal body **12** and microfilaments and/or nanofilaments **16**, as the molten metal solidifies.

[0034] The capacitor-discharge welding process is an extremely efficient method for welding a wide variety of metals including mild steel, stainless steel, aluminium, brass, copper, titanium, and other similar metals. A powerful bank of capacitors may be provided with each capacitor storing energy at a specific voltage. The capacitors may range

between 450-3000 volts. The voltage may depend on the size and material of the component being formed. Large capacitor-discharge welding machines may output 400 KA of current and 50 kJ of energy. When energy is discharged, a cohesive bond may be formed in approximately 0.004 seconds or more.

[0035] The capacitor-discharge welding process is advantageous for many reasons. The short welding time localizes the heat and creates welds adjacent to heat sensitive portions of the material. The capacitor-discharge welding process provides excellent bonding with a variety of similar and dissimilar materials without requiring any water cooling, significant power requirements, nor substantial operating costs for high production rates. This process may be performed in most environments as it does not require large amounts of space and produces very little, if any, fumes or smoke.

[0036] A different cohesive bonding method referred to as localized friction bonding is shown in FIG. 5. In the embodiment of FIG. 5, the method may comprise the step of contacting a metal body **12** with a surface **15** of a substrate **14**. The substrate **14** may comprise a plurality of microfilaments and/or nanofilaments **16** dispersed into and below the surface **15** of the substrate **14**. The surface of the metal body **12** may have microscopic asperities (not shown) as it will be appreciated most metal surfaces are not absolutely smooth. In contacting the metal body **12** to the surface **15** of the substrate **14**, the microscopic asperities **17** of the surface of the metal body **12** may come into contact with the microfilaments and/or nanofilaments **16** of the substrate **14**. The microfilaments and/or nanofilaments **16** provide microscopic asperities that aid in the bonding process and may contact the microscopic asperities **17** of the metal body **12**.

[0037] The method may also comprise the step of simultaneously applying normally-oriented pressure **20** on the metal body **12** and laterally-oriented high frequency and low amplitude vibration **22** to the substrate **14** as shown in FIG. 5. The application of the combined pressure and vibration may produce high temperatures localized between the adjoining surface of the metal body **12** and the microfilaments and/or nanofilaments **16** and may further facilitate metal transfer between the metal body **12** and the material of the microfilaments and/or nanofilaments **16** that is exposed at the surface **15** of the substrate **14**. This metal transfer may result in a

[0038] Friction bonding generally is a solid phase pressure welding process where little to no actual melting of the metal body occurs. By rubbing the adjoining surfaces of the metal body and the substrate together, sufficient heat is produced for creating local plastic zones. Accordingly, two atomically clean metal surfaces may be brought together under pressure and an inter-metallic bond is formed. The corresponding heat may be confined to the interface of the two materials. The heat input may be low and the amount of work applied to the bonded area results in grain refinement.

[0039] One advantageous characteristic associated with friction bonding is the ability to weld alloys and combinations of alloys which were previously regarded as "un-weldable." With localized friction bonding processes, it is now possible to produce dissimilar metal joints, join steel, copper, and aluminium to themselves and/or to each other, and to successfully weld alloys.

[0040] An alternate cohesive bonding method, ultrasonic welding, is shown in FIG. 6. In the embodiment of FIG. 6, the method may comprise the step of contacting a metal body **12** with a surface **15** of a substrate **14**. The substrate **14** may

comprise a plurality of microfilaments and/or nanofilaments **16** dispersed into and below the surface **15** of the substrate **14**. The surface of the metal body **12** may have microscopic asperities as it will be appreciated most metal surfaces are not absolutely smooth. A sonotrode **26** may be positioned to be in contact with a surface of the metal body **12**. Likewise, an anvil **27** may be positioned against a surface of the substrate **14** and it holds the materials to be welded statically together. A welding tool (not shown) may attach or couple to the material to be bonded and the tool moves in a longitudinal direction. The metal body **12** and substrate **14** may be pressed together and a generator (not shown) may produce electrical oscillations of ultrasonic frequency. In one embodiment, a transducer (not shown) may convert the electrical oscillations into mechanical vibration which in turn is transmitted to the sonotrode **26**. The sonotrode transmits the ultrasonic vibrations **28** to the metal body **12** and substrate **14**. Generally, the sonotrode **26** needs to be mounted tightly to the metal body **12** to avoid friction and other losses. The simultaneous action of static and dynamic forces causes the metal body **12** and substrate **14** to fuse together without requiring the addition of an extrinsic material.

[0041] For plastic materials, high frequency vertical vibrations are used to increase the temperature and plasticizes the materials. Vibrations may reach frequencies of about 20-70 kHz. During ultrasonic metal welding, a complex process is triggered involving static forces, oscillating shearing forces, and a moderate temperature increase in the welding area. The magnitude of these factors depends on the thickness of the work pieces (viz., the metal body **12** and substrate **14**), their surface structure, and their mechanical properties. Typical frequencies may reach 20-40 kHz, which is above the frequency that is audible to a human ear and also permits the best possible use of energy. Generally, ultrasonic welding is used for forming small components that require less energy such as watches, cassettes, plastic products, toys, medical tools, and packaging.

[0042] In the embodiment of FIG. 7, a resulting component **24** is formed from cohesive bonding between a metal body **12** and a substrate **14**. The metal body **12** may include microscopic asperities and the substrate may include a plurality of microfilaments and/or nanofilaments **16**. Other components may be formed via any of the above-described methods and the type of component being made should not be limiting.

[0043] While exemplary embodiments incorporating the principles of the present invention have been disclosed hereinabove, the present invention is not limited to the disclosed embodiments. Instead, this application is intended to cover any variations, uses, or adaptations of the invention using its general principles. Further, this application is intended to cover such departures from the present disclosure as come within known or customary practice in the art to which this invention pertains and which fall within the limits of the appended claims.

What is claimed is:

1. A method for cohesively bonding a metal body to a substrate comprising the steps of:

contacting the metal body to a surface of the substrate, the substrate comprising a plurality of microfilaments or nanofilaments dispersed into or below the surface of the substrate and the metal body surface comprising microscopic asperities which contact the plurality of microfilaments or nanofilaments;

applying normally-oriented pressure on the metal body and laterally-oriented high frequency and low amplitude vibrations to the substrate; and

forming a cohesive bond between the metal body and the substrate.

2. The method of claim 1, wherein the metal body comprises the surface of a metal strip, a metal sheet, a metal plate or a metal block.

3. The method of claim 1, wherein the metal body comprises stainless steel or a titanium alloy.

4. The method of claim 1, wherein the substrate is a composite material comprising a metal matrix composite, a polymer composite or a ceramic composite.

5. The method of claim 4, wherein the composite material is a polymer composite comprising unidirectional or multidirectional fibers of graphite, fiberglass or aramid.

6. The method of claim 1, wherein the plurality of microfilaments or nanofilaments comprise metal that is capable of diffusing into the metal body.

7. A method for cohesively bonding a metal body to a substrate comprising the steps of:

coupling a plurality of capacitors through a plurality of contact elements to the metal body and the substrate;

contacting the metal body to the substrate, the substrate comprising a plurality of microfilaments or nanofilaments, wherein the microfilaments or nanofilaments provide microscopic asperities on at least the substrate surface which contacts the metal body;

discharging energy from the plurality of capacitors to raise the temperature of the surfaces of the metal body and the substrate which contact one another;

applying pressure on the metal body or substrate; and

forming a cohesive bond between the metal body and the substrate.

8. The method of claim 7, wherein the contacting step occurs before the coupling step.

9. The method of claim 7, wherein the applying pressure step occurs simultaneously with or after the discharging step.

10. The method of claim 7, wherein the metal body consists of one of mild steel, stainless steel, aluminum, brass, copper, and titanium.

11. The method of claim 7, wherein the plurality of capacitors store energy at specific voltages dependent upon the size and material of a component being formed.

12. The method of claim 11, wherein the plurality of capacitors store energy at voltages between about 475-3000 volts.

13. The method of claim 7, wherein the forming step forms a cohesive bond free from distorting or discoloring.

14. The method of claim 7, further comprising creating an instantaneous arc which melts adjoining surfaces of the metal body and the substrate.

15. A method for cohesively bonding a metal body to a substrate comprising the steps of:

contacting the metal body to the substrate, the substrate comprising a plurality of microfilaments or nanofilaments, wherein the microfilaments or nanofilaments provide microscopic asperities on at least the substrate surface which contacts the metal body;

positioning a sonotrode to contact the metal body;

applying normally-oriented pressure on the metal body or substrate;

vibrating the metal body or substrate; and

forming a cohesive bond between the metal body and the substrate.

16. The method of claim **15**, wherein the vibrating step occurs at a frequency between about 20-70 kHz.

17. The method of claim **15**, further comprising increasing the temperature of the adjoining surfaces of the metal body and substrate.

18. The method of claim **15**, further comprising generating electrical oscillations of ultrasonic frequency.

19. The method of claim **18**, further comprising converting the electrical oscillations into mechanical vibration.

20. The method of claim **15**, wherein the cohesive bond is formed free from adding an extrinsic material such as an adhesive.

* * * * *