



US008970432B2

(12) **United States Patent**  
**Fix et al.**

(10) **Patent No.:** **US 8,970,432 B2**  
(45) **Date of Patent:** **Mar. 3, 2015**

(54) **FEMTOCELL CALIBRATION FOR TIMING  
BASED LOCATING SYSTEMS**

5,732,383 A 3/1998 Foladare et al.  
5,844,521 A 12/1998 Stephens et al.  
5,982,324 A 11/1999 Watters et al.  
6,018,312 A 1/2000 Haworth  
6,026,301 A 2/2000 Satarasinghe

(75) Inventors: **Jeremy Fix**, Acworth, GA (US);  
**Brandon Hilliard**, Woodstock, GA  
(US); **Sheldon Meredith**, Marietta, GA  
(US)

(Continued)

FOREIGN PATENT DOCUMENTS

(73) Assignee: **AT&T Mobility II LLC**, Atlanta, GA  
(US)

EP 0856746 A2 8/1998  
JP 2004069609 A 3/2004

(Continued)

(\*) Notice: Subject to any disclaimer, the term of this  
patent is extended or adjusted under 35  
U.S.C. 154(b) by 325 days.

OTHER PUBLICATIONS

Marko Silventoinen, Timo Rantalainen, "Mobile Station Locating in  
GSM" Helsinki, Finland, Last accessed on Nov. 15, 2011, 7 pages.

(Continued)

(21) Appl. No.: **13/305,267**

(22) Filed: **Nov. 28, 2011**

(65) **Prior Publication Data**

US 2013/0135148 A1 May 30, 2013

*Primary Examiner* — Dao Phan

(74) *Attorney, Agent, or Firm* — Amin, Turocy & Watson,  
LLP

(51) **Int. Cl.**  
**G01S 1/08** (2006.01)  
**G01S 3/02** (2006.01)  
**G01S 5/04** (2006.01)

(57) **ABSTRACT**

Systems and methods disclosed herein can implement a femto-  
cell calibration solution that uses the known location of the  
femtocell to calibrate timing based locating systems. The  
calculated time differences of different signals sent between  
macrocells and a mobile device can be used to solve for a  
reference time difference that accounts for the timing differ-  
ences of the unsynchronized macrocells. The reference time  
difference can then be used to solve for the location of another  
mobile device if the calculated time differences between that  
mobile device and the macrocells are known. The solution  
can include taking many measurements of the calculated time  
difference at the first mobile device in order to average them  
to get a more accurate reference time difference. The solution  
can further include ceasing measurements at the first mobile  
device when the mobile device is no longer within range of  
the femtocell.

(52) **U.S. Cl.**  
USPC ..... **342/386**; 342/442; 342/457

(58) **Field of Classification Search**  
CPC ..... G01S 5/06; G01S 3/48; H04W 64/00  
USPC ..... 342/357.25, 386, 387, 442, 444, 457;  
455/456.2, 456.6

See application file for complete search history.

(56) **References Cited**

U.S. PATENT DOCUMENTS

4,718,081 A 1/1988 Brenig  
5,515,062 A 5/1996 Maine et al.  
5,724,660 A 3/1998 Kauser et al.  
5,732,354 A 3/1998 MacDonald

**20 Claims, 10 Drawing Sheets**

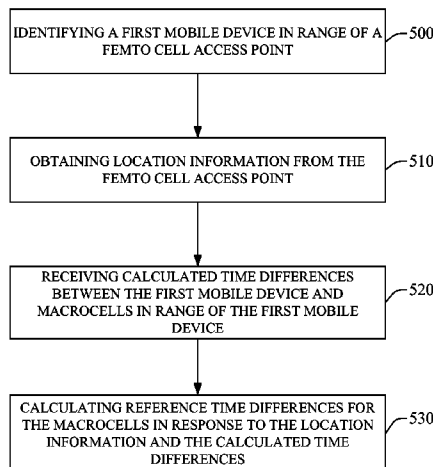

(56)

## References Cited

## U.S. PATENT DOCUMENTS

6,108,532 A	8/2000	Matsuda et al.	8,054,802 B2	11/2011	Burgess et al.
6,108,556 A	8/2000	Ito	8,121,604 B1	2/2012	Schwinghammer
6,148,219 A	11/2000	Engelbrecht et al.	8,140,079 B2	3/2012	Olson
6,216,002 B1	4/2001	Holmring	8,193,984 B2	6/2012	Ward et al.
6,230,018 B1	5/2001	Watters et al.	8,194,589 B2	6/2012	Wynn et al.
6,256,577 B1	7/2001	Graunke	8,195,175 B2	6/2012	Govindan et al.
6,263,190 B1	7/2001	Mamori et al.	8,224,349 B2	7/2012	Meredith et al.
6,298,233 B1	10/2001	Souissi et al.	8,253,559 B2	8/2012	Howard et al.
6,307,503 B1	10/2001	Liu et al.	8,254,959 B2	8/2012	Fix et al.
6,311,078 B1	10/2001	Hardouin et al.	8,264,956 B2	9/2012	Ramankutty et al.
6,317,686 B1	11/2001	Ran	8,270,933 B2	9/2012	Riemer et al.
6,330,459 B1	12/2001	Chrichton et al.	8,280,438 B2	10/2012	Barbera et al.
6,351,235 B1	2/2002	Stilp	8,295,854 B2	10/2012	Osann et al.
6,353,778 B1	3/2002	Brown et al.	8,307,030 B1	11/2012	Hu
6,397,074 B1	5/2002	Pihl et al.	8,355,364 B1	1/2013	Vargantwar et al.
6,405,047 B1	6/2002	Moon	8,355,865 B2	1/2013	Wagner et al.
6,407,703 B1	6/2002	Minter et al.	8,417,264 B1	4/2013	Whitney et al.
6,429,815 B1	8/2002	Soliman	8,548,494 B2	10/2013	Agarwal et al.
6,434,396 B1	8/2002	Rune	8,594,700 B2	11/2013	Nabbefeld
6,453,168 B1	9/2002	McCrary et al.	8,666,388 B2	3/2014	Catovic et al.
6,493,539 B1	12/2002	Falco et al.	8,666,390 B2	3/2014	Meredith et al.
6,515,623 B2	2/2003	Johnson	2001/0047242 A1	11/2001	Ohta
6,522,296 B2	2/2003	Holt	2002/0059266 A1	5/2002	I'anson et al.
6,526,335 B1	2/2003	Treyz et al.	2002/0069312 A1	6/2002	Jones
6,560,532 B2	5/2003	Cayford	2002/0077116 A1	6/2002	Havinis et al.
6,560,567 B1	5/2003	Yechuri et al.	2002/0172223 A1	11/2002	Stilp et al.
6,594,576 B2	7/2003	Fan et al.	2003/0092448 A1	5/2003	Forstrom et al.
6,604,083 B1	8/2003	Bailey et al.	2003/0097330 A1	5/2003	Hillmer et al.
6,668,226 B2	12/2003	Sutanto et al.	2003/0115260 A1	6/2003	Edge
6,690,292 B1	2/2004	Meadows et al.	2003/0125046 A1	7/2003	Riley et al.
6,744,383 B1	6/2004	Alfred et al.	2003/0158924 A1	8/2003	DeLegge
6,744,740 B2	6/2004	Chen	2003/0222819 A1	12/2003	Karr et al.
6,757,545 B2	6/2004	Nowak et al.	2003/0225508 A9	12/2003	Petzld et al.
6,801,782 B2	10/2004	McCrary et al.	2004/0067759 A1	4/2004	Spirito et al.
6,801,855 B1	10/2004	Walters et al.	2004/0082338 A1	4/2004	Norrgard et al.
6,816,782 B1	11/2004	Walters et al.	2004/0127191 A1	7/2004	Matsunaga
6,850,761 B2	2/2005	Pallonen	2004/0131036 A1	7/2004	Walsh
6,892,054 B2	5/2005	Belcher et al.	2004/0155814 A1	8/2004	Bascobert
6,933,100 B2	8/2005	Igawa et al.	2004/0172190 A1	9/2004	Tsunehara et al.
6,933,860 B1	8/2005	Gehman et al.	2004/0219930 A1	11/2004	Lin
7,065,349 B2	6/2006	Nath et al.	2004/0224698 A1	11/2004	Yi et al.
7,098,805 B2	8/2006	Meadows et al.	2005/0007993 A1	1/2005	Chambers et al.
7,113,793 B2	9/2006	Veerasingam et al.	2005/0039056 A1	2/2005	Bagga et al.
7,149,534 B2	12/2006	Bloebaum et al.	2005/0053099 A1	3/2005	Spear et al.
7,181,218 B2	2/2007	Ovesjo et al.	2005/0136911 A1	6/2005	Csapo et al.
7,277,049 B2	10/2007	Korneluk et al.	2005/0239410 A1	10/2005	Rochester
7,289,039 B2	10/2007	Kato et al.	2005/0272445 A1	12/2005	Zellner
7,346,359 B2	3/2008	Damarla et al.	2005/0276385 A1	12/2005	McCormick et al.
7,359,719 B1	4/2008	Duffett-Smith et al.	2006/0030333 A1	2/2006	Ward et al.
7,366,492 B1	4/2008	Ganesh	2006/0046744 A1	3/2006	Dublish et al.
7,375,649 B2	5/2008	Gueziec	2006/0075131 A1	4/2006	Douglas et al.
7,432,829 B2	10/2008	Poltorak	2006/0089153 A1	4/2006	Sheynblat
7,436,794 B2	10/2008	Takahashi et al.	2006/0240839 A1	10/2006	Chen et al.
7,508,321 B2	3/2009	Gueziec	2006/0267841 A1	11/2006	Lee et al.
7,664,492 B1	2/2010	Lee et al.	2006/0270419 A1	11/2006	Crowley et al.
7,696,922 B2	4/2010	Nicholson et al.	2006/0282660 A1	12/2006	Varghese et al.
7,697,917 B2	4/2010	Camp et al.	2007/0001873 A1	1/2007	Ishikawa et al.
7,706,964 B2	4/2010	Horvitz et al.	2007/0060130 A1	3/2007	Gogic et al.
7,744,740 B2	6/2010	Diehl	2007/0176749 A1	8/2007	Boyd
7,747,258 B2	6/2010	Farmer et al.	2007/0213074 A1	9/2007	Fitch et al.
7,761,225 B2	7/2010	Vaughn	2007/0217375 A1	9/2007	Zampielo et al.
7,831,380 B2	11/2010	Chapman et al.	2007/0217379 A1	9/2007	Fujiwara et al.
7,848,880 B2	12/2010	Cheung	2007/0293157 A1	12/2007	Haartsen et al.
7,890,299 B2	2/2011	Fok et al.	2007/0298807 A1	12/2007	Yarkosky
7,917,156 B2	3/2011	Sheynblat et al.	2008/0004789 A1	1/2008	Horvitz et al.
7,945,271 B1	5/2011	Barnes et al.	2008/0010365 A1	1/2008	Schneider
7,958,001 B2	6/2011	Abbadessa et al.	2008/0039114 A1	2/2008	Phatak et al.
7,962,162 B2	6/2011	McNair	2008/0070593 A1	3/2008	Altman et al.
7,962,280 B2	6/2011	Kindo et al.	2008/0071466 A1	3/2008	Downs et al.
7,994,981 B1	8/2011	Farrokhi et al.	2008/0076450 A1	3/2008	Nanda et al.
7,996,020 B1	8/2011	Chhabra	2008/0096566 A1	4/2008	Brunner et al.
8,000,726 B2	8/2011	Altman et al.	2008/0133730 A1	6/2008	Park et al.
8,005,050 B2	8/2011	Scheinert et al.	2008/0186234 A1	8/2008	Alles et al.
8,010,164 B1	8/2011	Sennett et al.	2008/0192682 A1	8/2008	Matsumoto et al.
8,036,822 B2	10/2011	Ho et al.	2008/0274750 A1	11/2008	Carlson et al.
			2008/0299995 A1	12/2008	Spain
			2008/0305832 A1	12/2008	Greenberg
			2008/0311923 A1	12/2008	Petrovic et al.
			2009/0024546 A1	1/2009	Ficcaglia et al.

(56)

## References Cited

## U.S. PATENT DOCUMENTS

2009/0052330 A1 2/2009 Matsunaga et al.  
 2009/0079622 A1 3/2009 Seshadri et al.  
 2009/0104917 A1 4/2009 Ben Rached et al.  
 2009/0117907 A1 5/2009 Wigren et al.  
 2009/0131073 A1 5/2009 Carlson et al.  
 2009/0181695 A1 7/2009 Wirola et al.  
 2009/0260055 A1 10/2009 Parmar  
 2009/0280828 A1 11/2009 Wang et al.  
 2009/0286510 A1 11/2009 Huber et al.  
 2009/0287922 A1 11/2009 Herwono et al.  
 2009/0310501 A1 12/2009 Catovic et al.  
 2009/0327134 A1 12/2009 Carlson et al.  
 2010/0020776 A1 1/2010 Youssef et al.  
 2010/0054237 A1 3/2010 Han et al.  
 2010/0058442 A1 3/2010 Costa et al.  
 2010/0081389 A1 4/2010 Lawrow  
 2010/0100732 A1 4/2010 Hatakeyama et al.  
 2010/0113035 A1 5/2010 Eskicioglu et al.  
 2010/0120447 A1\* 5/2010 Anderson et al. .... 455/456.1  
 2010/0124931 A1 5/2010 Eskicioglu et al.  
 2010/0135178 A1 6/2010 Aggarwal et al.  
 2010/0144368 A1 6/2010 Sullivan  
 2010/0159951 A1 6/2010 Shkedi et al.  
 2010/0172259 A1 7/2010 Aggarwal et al.  
 2010/0189236 A1 7/2010 MacDonald  
 2010/0190509 A1 7/2010 Davis et al.  
 2010/0195566 A1 8/2010 Krishnamurthy et al.  
 2010/0203903 A1 8/2010 Dingler et al.  
 2010/0207470 A1 8/2010 Kim et al.  
 2010/0220665 A1 9/2010 Govindan et al.  
 2010/0222075 A1 9/2010 Miura  
 2010/0227589 A1 9/2010 Cook et al.  
 2010/0250542 A1 9/2010 Fujimaki  
 2010/0299060 A1 11/2010 Snaveily et al.  
 2010/0311437 A1 12/2010 Palanki et al.  
 2010/0313157 A1 12/2010 Carlsson et al.  
 2010/0323723 A1 12/2010 Gerstenberger et al.  
 2010/0331013 A1 12/2010 Zhang  
 2011/0009068 A1 1/2011 Miura  
 2011/0010085 A1 1/2011 Tanaka et al.  
 2011/0023129 A1 1/2011 Vernal  
 2011/0053609 A1 3/2011 Grogan et al.  
 2011/0060808 A1 3/2011 Martin et al.  
 2011/0065450 A1 3/2011 Kazmi  
 2011/0072034 A1 3/2011 Sly  
 2011/0076975 A1 3/2011 Kim et al.  
 2011/0077032 A1 3/2011 Correale et al.  
 2011/0161261 A1 6/2011 Wu et al.  
 2011/0164596 A1 7/2011 Montemurro et al.  
 2011/0171912 A1 7/2011 Beck et al.  
 2011/0172905 A1 7/2011 Schroder et al.  
 2011/0205964 A1 8/2011 Fix et al.  
 2011/0207470 A1 8/2011 Meredith et al.  
 2011/0210843 A1 9/2011 Kummetz  
 2011/0210849 A1 9/2011 Howard et al.  
 2011/0244879 A1 10/2011 Siomina et al.  
 2011/0256874 A1 10/2011 Hayama et al.  
 2011/0271331 A1 11/2011 Adams  
 2011/0296169 A1 12/2011 Palmer  
 2011/0319098 A1 12/2011 Potorny et al.  
 2012/0016902 A1 1/2012 Ranjan et al.  
 2012/0025976 A1 2/2012 Richey et al.  
 2012/0028650 A1 2/2012 Cooper et al.  
 2012/0030083 A1 2/2012 Newman et al.  
 2012/0032855 A1 2/2012 Reede et al.  
 2012/0052884 A1 3/2012 Bogatin  
 2012/0062415 A1 3/2012 Hwang et al.  
 2012/0087338 A1 4/2012 Brandt et al.  
 2012/0139782 A1 6/2012 Gutt et al.  
 2012/0158289 A1 6/2012 Bernheim Brush et al.  
 2012/0182874 A1 7/2012 Siomina et al.  
 2012/0287911 A1 11/2012 Takano et al.  
 2012/0317500 A1 12/2012 Kosseifi et al.  
 2012/0323703 A1 12/2012 Hillier et al.  
 2013/0007058 A1 1/2013 Meredith et al.

2013/0023237 A1 1/2013 Meredith et al.  
 2013/0023274 A1 1/2013 Meredith et al.  
 2013/0023281 A1 1/2013 Meredith et al.  
 2013/0281111 A1 10/2013 Syrjarinne et al.  
 2013/0324149 A1 12/2013 Fix et al.  
 2014/0062782 A1 3/2014 Abraham  
 2014/0171060 A1 6/2014 Cook et al.

## FOREIGN PATENT DOCUMENTS

JP 2007328050 A 12/2007  
 WO WO2006031035 A1 3/2006

## OTHER PUBLICATIONS

Office Action dated Mar. 25, 2014 for U.S. Appl. No. 13/488,144, 60 Pages.

Interview Summary dated Feb. 3, 2014 for U.S. Appl. No. 13/188,136, 10 pages.

Rabinowitz, et al., A new positioning system using television synchronization signals, IEEE Transactions on Broadcasting, vol. 51(1), p. 51-61, Mar. 2005.

Final Office Action dated Apr. 3, 2014 for U.S. Appl. No. 13/188,295, 37 pages.

3rd Generation Partnership Project, Technical Specification, "Group GSM/EDGE Radio Access Network, Radio subsystem synchronization (Release 8)", 3GPP TS 45.010 V8.0.0 (May 2008), last viewed Jul. 1, 2009, 30 pages.

3rd Generation Partnership Project, Technical Specification, "Group Radio Access Network, UTRAN Iuh interface Node B Application Part (NBAP) signalling (Release 8)", 3GPP TS 25.469 V8.0.0 (Dec. 2008), last viewed Jul. 1, 2009, 56 pages.

Sullivan, Mark. "Signs and Wonders: Is AT&T Stepping Up Its Game?" PC World, Dec. 10, 2009, 1 page.

ETSI TS 125 215 V6.4.0 (Sep. 2005). Universal Mobile Telecommunications System (UMTS), Physical layer, Measurements (FDD), 3GPP TS 25.215 version 6.4.0 Release 6). Last accessed Jun. 18, 2010, 20 pages.

ETSI TS 125 331 V6.9.0 (Mar. 2006). Universal Mobile Telecommunications System (UMTS), Radio Resource Control (RRC) protocol specification, (3GPP TS 25.331 version 6.9.0 Release 6). Last accessed Jun. 18, 2010, 1211 pages.

New Devices Aim to Disable Cell Phones While Driving. FOXNews.com, Jan. 18, 2009. [http://www.foxnews.com/printer\\_friendly\\_story/0,3566,480585,00.html](http://www.foxnews.com/printer_friendly_story/0,3566,480585,00.html). Last accessed Nov. 24, 2010, 2 pages.

Cortes, et al. "Support-Vector Networks", Machine Learning, 20, 1995. <http://www.springerlink.com/content/k238jx04hm87j80g/fulltext.pdf>. Last accessed Dec. 24, 2010, 25 pages.

ACM Website, Press release of Mar. 17, 2009. <http://www.acm.org/press-room/news-releases/pdfs/awards-08-group1.pdf>. Last accessed Dec. 24, 2010, 3 pages.

Boser, et al. A training algorithm for optimal margin classifiers. In D. Haussler, editor, 5th Annual ACM Workshop on COLT, pp. 144-152, Pittsburgh, PA, 1992. ACM Press. <http://citeseerx.ist.psu.edu/viewdoc/summary?doi=10.1.1.21.3818>. Last accessed Dec. 24, 2010, 9 pages.

Hsu, et al. A Practical Guide to Support Vector Classification. Department of Computer Science National Taiwan University, Last updated: Apr. 15, 2010. <http://www.csie.ntu.edu.tw/~cjlin/papers/guide/guide.pdf>. Last accessed Dec. 24, 2010, 16 pages.

Drucker, et al. Support Vector Regression Machines. <http://scholar.google.com/scholar?q=%22Support+Vector+Regression+Machines.%22>. Last accessed Dec. 24, 2010, 7 pages.

Suykens et al., "Least squares support vector machine classifiers", Neural Processing Letters, vol. 9, No. 3, Jun. 1999, pp. 293-300.

Ferris et al. (2002). "Interior-point methods for massive support vector machines". SIAM Journal on Optimization 13: 783-804. doi:10.1137/S1052623400374379.

Meyer et al. "The support vector machine under test." Neurocomputing 55(1-2): 169-186, 2003.

International Search Report for PCT Application No. US2011/026122, dated Sep. 10, 2011, 11 pages.

(56)

**References Cited**

## OTHER PUBLICATIONS

International Search Report for PCT Application No. US2011/026120, dated Sep. 9, 2011 13 pages.

Charitanetra et al. "Mobile positioning location using E-OTD method for GSM network" Research and Development, 2003. Proceedings Student Conference on Putrajaya, Malaysia Aug. 25-26, 2003, pp. 319-324.

"Location Labs Powers Location-based Fraud Detection", All Points Blog, [http://webcache.googleusercontent.com/search?hl=en&rlz=1R2GFRE\\_enUS398&q=cache:trsMn9Sin6wJ:http://apb.directionsmag.com/entry/location-labs-powers-location-based-fraud-detection/162802+http%3A//apb.directionsmag.com/entry/location-labs-powers-location-based-...1&ct=cInk](http://webcache.googleusercontent.com/search?hl=en&rlz=1R2GFRE_enUS398&q=cache:trsMn9Sin6wJ:http://apb.directionsmag.com/entry/location-labs-powers-location-based-fraud-detection/162802+http%3A//apb.directionsmag.com/entry/location-labs-powers-location-based-...1&ct=cInk), Oct. 12, 2010. "Location Based Fraud Detection", Finsphere Corporation, 2008-2010.

Fleishman. Using the Personal Hotspot on your AT & T iPhone. Published online Mar. 15, 2011. [http://www.macworld.com/article/158556/2011/03/personal\\_hotspot\\_att...4](http://www.macworld.com/article/158556/2011/03/personal_hotspot_att...4) pages.

Fleischfresser. Never Stop at a Red-Light Again. Published online Aug. 30, 2011. <http://www.smartplanet.com/blog/...2> pages.

Cellphone Networks and the Future of Traffic. Published online Mar. 2, 2011. <http://m.wired.com/autopia/2011/03/cell-phone-networks-and-the-future-...15> pages.

Ban Xuegang(Jeff), Gruteser Marco. Mobile Sensor as Traffic Probes: Addressing Transportation Modeling and Privacy Protection in an Integrated Framework. Dated Jan. 10, 2010. 17 pages.

Office Action dated Dec. 28, 2011 for U.S. Appl. No. 12/836,471, 34 pages.

Office Action dated Feb. 23, 2012 for U.S. Appl. No. 12/967,747, 31 pages.

Office Action dated Dec. 15, 2011 for U.S. Appl. No. 12/712,424, 34 pages.

Office Action dated Apr. 13, 2012 for U.S. Appl. No. 12/416,853, 36 pages.

Office Action dated Oct. 2, 2012 for U.S. Appl. No. 13/554,285, 19 pages.

Office Action dated Aug. 30, 2012 for U.S. Appl. No. 12/958,146, 40 pages.

MobileLutions Introduces MobiLoc—A Breakthrough Technology to Control Texting in the Mobile Workplace. Press release Oct. 10, 2010 by MobileLutions. 2 pages.

DriveAssist Frequently Ask question by Aegis Mobility, Wayback archive Jul. 12, 2010, 2 pages.

Office Action dated Jul. 30, 2012 for U.S. Appl. No. 12/967,747, 28 pages.

Office Action dated Jul. 17, 2012 for U.S. Appl. No. 13/220,083, 57 pages.

Office Action dated Sep. 11, 2012 for U.S. Appl. No. 13/188,345, 44 pages.

Office Action dated Oct. 15, 2012 for U.S. Appl. No. 13/523,778, 21 pages.

Office Action dated Dec. 20, 2012 for U.S. Appl. No. 12/958,146, 23 pages.

Office Action dated Dec. 28, 2012 for U.S. Appl. No. 13/188,295, 37 pages.

Office Action dated Jan. 3, 2013 for U.S. Appl. No. 13/188,300, 36 pages.

Office Action dated Nov. 8, 2012 for U.S. Appl. No. 13/204,535, 30 pages.

Final Office Action dated Jan. 25, 2013, for U.S. Appl. No. 13/554,285, 20 pgs.

Non-Final Office Action dated Mar. 19, 2013, for U.S. Appl. No. 13/174,541, 46 pgs.

Final Office Action dated Feb. 13, 2013, for U.S. Appl. No. 13/220,083, 48 pgs.

Final Office Action dated Feb. 22, 2013, for U.S. Appl. No. 13/188,345, 45 pgs.

Final Office Action dated Mar. 15, 2013, for U.S. Appl. No. 13/204,535, 18 pgs.

Non-Final Office Action dated Mar. 19, 2013, for U.S. Appl. No. 13/284,497, 46 pgs.

Non-Final Office Action dated Apr. 19, 2013, for U.S. Appl. No. 13/277,595, 58 pages.

Notice of Allowance mailed Aug. 12, 2013, for U.S. Appl. No. 13/174,541, 40 pages.

Final Office Action dated Aug. 2, 2013, for U.S. Appl. No. 13/188,295, 26 pages.

Final Office Action dated Aug. 2, 2013, for U.S. Appl. No. 13/188,300, 38 pages.

Non-Final Office Action dated Jun. 20, 2013, for U.S. Appl. No. 13/219,911, 61 pages.

Non-Final Office Action dated Jul. 17, 2013, for U.S. Appl. No. 13/188,345, 27 pages.

Non-Final Office Action dated Jun. 20, 2013, for U.S. Appl. No. 13/291,917, 52 pages.

Non-Final Office Action dated May 31, 2013, for U.S. Appl. No. 13/523,770, 40 pages.

Non-Final Office Action dated Sep. 19, 2013, for U.S. Appl. No. 13/927,020, 30 pages.

Non-Final Office Action dated Oct. 2, 2013 for U.S. Appl. No. 12/958,146, 31 pages.

Non-Final Office Action dated Sep. 26, 2013 for U.S. Appl. No. 13/284,456, 58 pages.

RouteFinder 3.00 for ArcGIS Documentation, © 2007 Routeware and Higher Mapping Solutions, 71 pages, downloaded from [http://www.routeware.dk/download/routefinder\\_arcgis.pdf](http://www.routeware.dk/download/routefinder_arcgis.pdf).

mySociety (Web page), "More travel-time maps and their uses", 2007, downloaded from <http://www.mySociety.org/2007/more-travel-maps/>, 10 pages total (including a single page Examiner's attachment showing the operation of the interactive travel-time map).

Wayback machine archive from Jan. 21, 2009 of the mySociety Web page, "More travel-time maps and their uses", downloaded from <http://web.archive.org/web/20090121193615/http://www.mysociety.org/2007/more-travel-maps/>, 11 pages.

Street, Nicholas, "TimeContours: Using isochrone visualisation to describe transport network travel cost", Final Report, Jun. 14, 2006, Department of Computing Imperial College London, 97 pages. Downloaded from <http://www.doc.ic.ac.uk/teaching/projects/Distinguished06/nicholasstreet.pdf>.

Non-Final Office Action dated Nov. 5, 2013 for U.S. Appl. No. 13/188,136, 47 pages.

Final Office Action dated Sep. 18, 2013, for U.S. Appl. No. 13/284,497, 30 pages.

Final Office Action dated Aug. 22, 2013, for U.S. Appl. No. 13/277,595, 36 pages.

Final Office Action dated Oct. 21, 2013, for U.S. Appl. No. 13/523,770, 24 pages.

Office Action dated Nov. 5, 2013 for U.S. Appl. No. 13/188,345, 30 pages.

Non-Final Office Action dated Dec. 11, 2013, for U.S. Appl. No. 13/188,295, 52 pages.

Non-Final Office Action dated Dec. 24, 2013, for U.S. Appl. No. 13/188,300, 44 pages.

Final Office Action dated Dec. 11, 2013, for U.S. Appl. No. 13/291,917, 34 pages.

Final Office Action dated Jan. 15, 2014 for U.S. Appl. No. 13/219,911, 38 pages.

Final Office Action dated Jan. 28, 2014, for U.S. Appl. No. 12/958,146, 24 pages.

Notice of Allowance dated Feb. 14, 2014 for U.S. Appl. No. 13/284,456, 30 pages.

Final Office Action dated Feb. 24, 2014, for U.S. Appl. No. 13/927,020, 18 pages.

Office Action dated May 21, 2013 for U.S. Appl. No. 13/305,276, 28 pages.

Office Action dated Oct. 24, 2012 for U.S. Appl. No. 13/305,276, 37 pages.

"Locate your friends in real time with Google Latitude." <http://googlemobile.blogspot.com/2009/02/locate-your-friends-in-real-time-with.html>. Last accessed Mar. 8, 2012, 23 pages.

(56)

**References Cited**

## OTHER PUBLICATIONS

"Location sharing and updating." <http://support.google.com/mobile/bin/answer.py?hl=en&answer=136647>. Last accessed Mar. 8, 2012, 3 pages.

"Privacy Settings." <http://support.google.com/mobile/bin/answer.py?hl=en&answer=136650>, Last accessed Mar. 8, 2012, 1 page.

Office Action dated Nov. 25, 2013 for U.S. Appl. No. 13/447,069, 40 pages.

Office Action dated May 9, 2013 for U.S. Appl. No. 13/447,069, 33 pages.

Tsai, et al, "Location-Sharing Technologies: Privacy Risks and Controls." Feb. 2010. Retrieved on May 10, 2013, 26 pages.

Li et al, "Sharing Location in Online Social Networks". IEEE Network, Sep./Oct. 2010; 0890-8044/10/\$25.00 (c)2010 IEEE. Retrieved on May 10, 2013, 6 pages.

Tsai, et al, "Who's Viewed You? The Impact of Feedback in a Mobile Location-Sharing Application". CHI 2009—Security and Privacy, Apr. 9, 2009—Boston, MA, USA. Retrieved on May 10, 2013, 10 pages.

Pettersen, et al., "Automatic antenna tilt control for capacity enhancement in UMTS FDD." Retrieved on Mar. 25, 2012, 5 pages.

Islam, et al., "Self-Optimization of Antenna Tilt and Pilot Power for Dedicated Channels." Retrieved on Mar. 25, 2012, 8 pages.

Bigham, et al., "Tilting and Beam-shaping for Traffic Load Balancing in WCDMA Network." Retrieved on Mar. 25, 2012, 4 pages.

3GPP TS 25.215 V6.4.0 (Sep. 2005) Physical Layer Measurements. 3GPP TS 25.331 V6.9.0 (Mar. 2006) RRC protocol for the UE-UTRAN radio interface.

3GPP TS 25.413 V6.9.0 (Mar. 2006) UTRAN Iu interface RANAP signalling.

Calabrese, et al., "Real-Time Urban Monitoring Using Cell Phones: A Case Study in Rome". IEEE Transactions on Intelligent Transportation Systems, 12 pages. ([http://senseable.mit.edu/papers/pdf/2010\\_Calabrese\\_et\\_al\\_Rome\\_TITS.pdf](http://senseable.mit.edu/papers/pdf/2010_Calabrese_et_al_Rome_TITS.pdf)). Retrieved on Sep. 29, 2012, 11 pages.

Smith, et al., "Airsage Overview", (<http://mikeontraffic.typepad.com/files/raleigh-winter-2011-presentation-v11-final.pdf>) Retrieved on Sep. 29, 2012, 39 pages.

Office Action dated Feb. 5, 2014 for U.S. Appl. No. 13/526,988, 56 pages.

Office Action dated Jul. 22, 2014 for U.S. Appl. No. 12/958,146, 38 Pages.

Notice of Allowance dated Jul. 22, 2014 for U.S. Appl. No. 13/525,065, 82 Pages.

Notice of Allowance dated Jul. 7, 2014 for U.S. Appl. No. 13/188,295, 51 pages.

Notice of Allowance dated Jul. 22, 2014 for U.S. Appl. No. 13/188,300, 49 Pages.

Office Action dated Aug. 8, 2014 for U.S. Appl. No. 13/284,497, 48 pages.

Office Action dated Aug. 11, 2014 for U.S. Appl. No. 14/279,176, 22 pages.

Office Action dated Apr. 8, 2014 for U.S. Appl. No. 13/175,199, 52 pages.

Office Action dated Apr. 23, 2014 for U.S. Appl. No. 13/291,917, 29 pages.

Office Action dated Apr. 22, 2014 for U.S. Appl. No. 13/447,069, 51 pages.

Office Action dated Sep. 20, 2012 for U.S. Appl. No. 12/870,254, 29 pages.

Office Action dated May 14, 2014 for U.S. Appl. No. 13/660,689, 62 pages.

Office Action dated May 9, 2014 for U.S. Appl. No. 13/188,136, 33 pages.

Squires, "Practical Physics", Cambridge University Press, p. 12, 1986, 3 pages.

Represent (2000). In Collins English dictionary. Retrieved from <http://search.credoreference.com/content/entry/hcengdict/represent/0>, 2 pages.

Represent. (2001). In Chambers 21 st century dictionary. Retrieved from <http://search.credoreference.com/content/entry/chambdict/represent/0>.

Represent. (2011). In the american heritage dictionary of the english language. Retrieved from <http://search.credoreference.com/content/entry/hmdictenglang/represent/0>.

Non-Final Office Action dated May 20, 2014 for U.S. Appl. No. 13/551,369, 29 pages.

Non-Final Office Action dated May 30, 2014 for U.S. Appl. No. 13/277,595, 49 pages.

Non-Final Office Action dated Jun. 3, 2014 for U.S. Appl. No. 13/523,770, 53 pages.

Non-Final Office Action dated Jun. 6, 2014 for U.S. Appl. No. 13/447,072, 25 pages.

Office Action dated Jun. 18, 2014 for U.S. Appl. No. 13/305,276, 26 Pages.

Office Action dated Jun. 26, 2014 for U.S. Appl. No. 13/557,425, 24 Pages.

Office Action dated Nov. 14, 2014 for U.S. Appl. No. 13/277,595, 74 pages.

Notice of Allowance dated Nov. 20, 2014 for U.S. Appl. No. 13/866,909, 27 pages.

Notice of Allowance dated Dec. 9, 2014 for U.S. Appl. No. 12/958,146, 48 pages.

Office Action dated Dec. 11, 2014 for U.S. Appl. No. 13/447,072, 28 pages.

Office Action dated Dec. 1, 2014 for U.S. Appl. No. 13/495,756, 76 pages.

Office Action dated Jan. 7, 2015 for U.S. Appl. No. 13/557,425, 30 pages.

Notice of Allowance dated Aug. 21, 2014 for U.S. Appl. No. 13/447,069, 78 pages.

Office Action dated Aug. 28, 2014 for U.S. Appl. No. 13/526,988, 83 pages.

Office Action dated Sep. 22, 2014 for U.S. Appl. No. 13/175,199, 62 pages.

Office Action dated Oct. 17, 2014 for U.S. Appl. No. 13/204,535, 47 pages.

Office Action dated Oct. 20, 2014 for U.S. Appl. No. 13/494,959, 64 pages.

Office Action dated Oct. 22, 2014 for U.S. Appl. No. 13/557,425, 59 pages.

\* cited by examiner

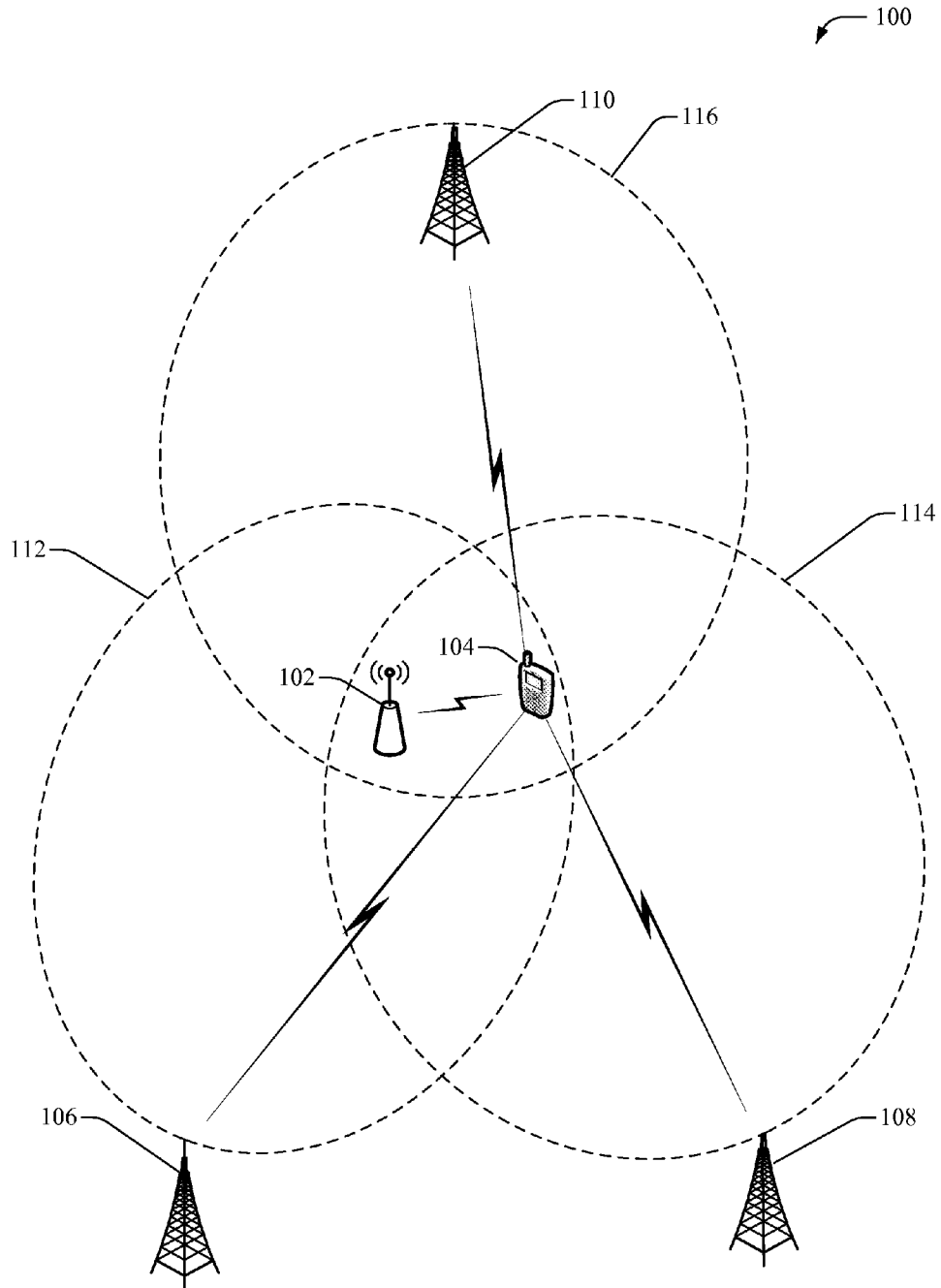

FIG. 1

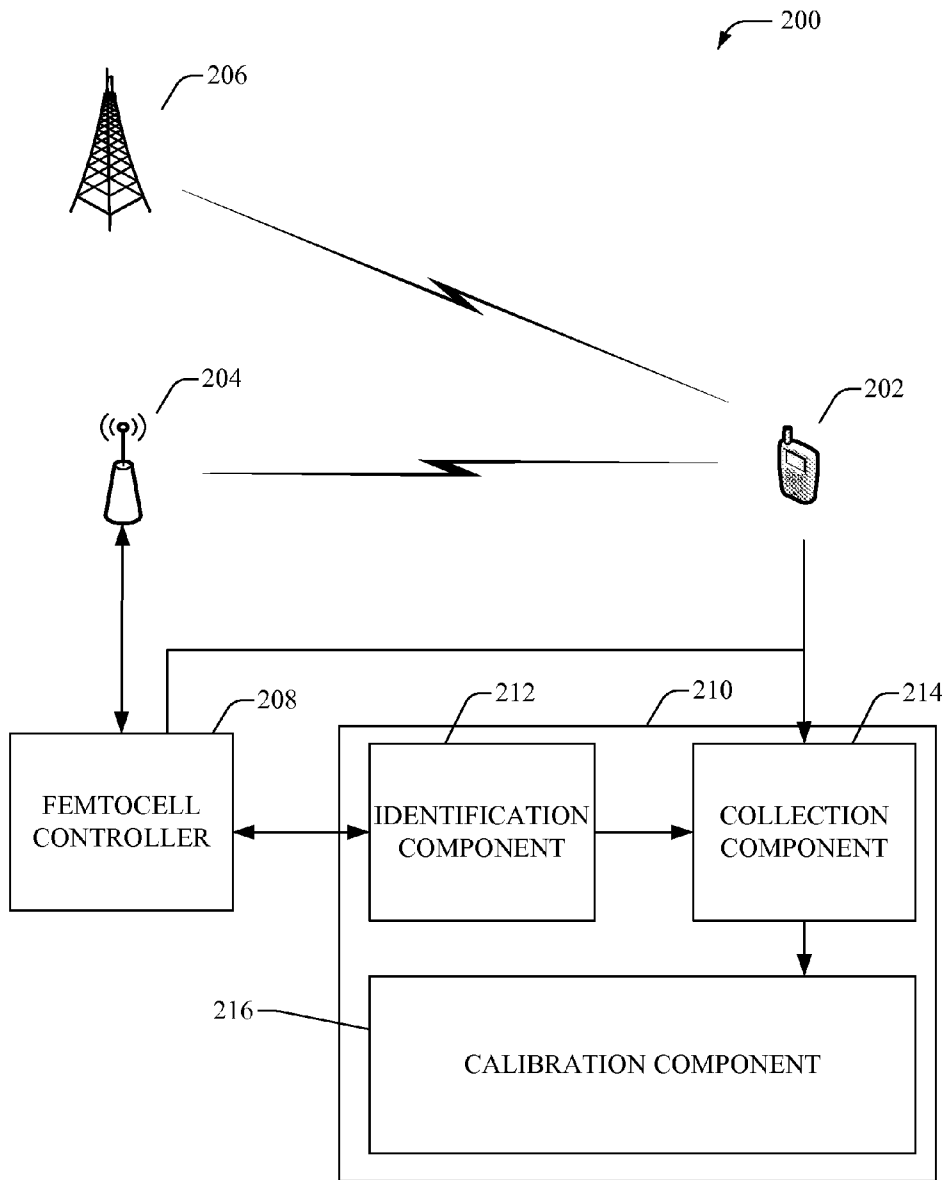
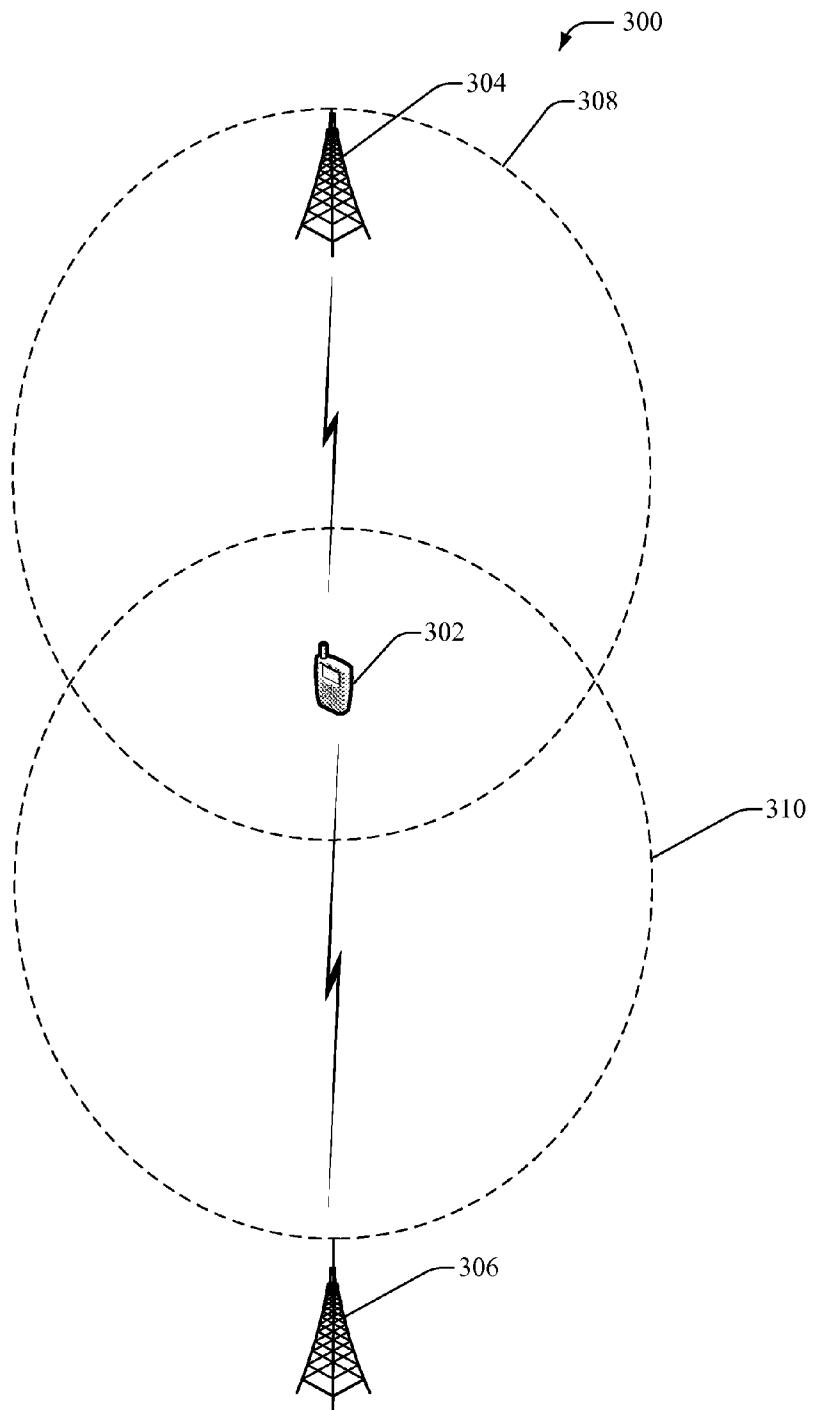
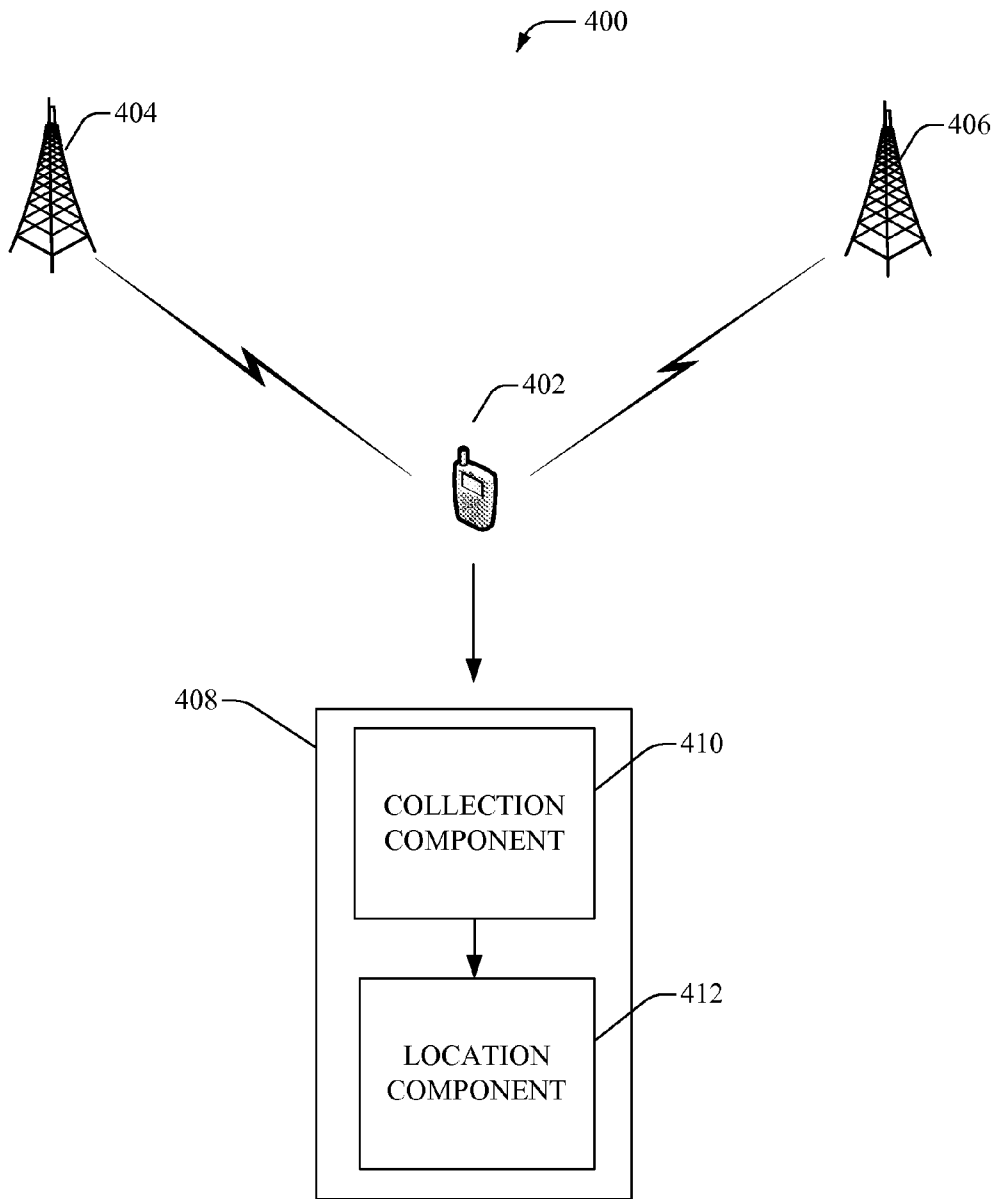

FIG. 2

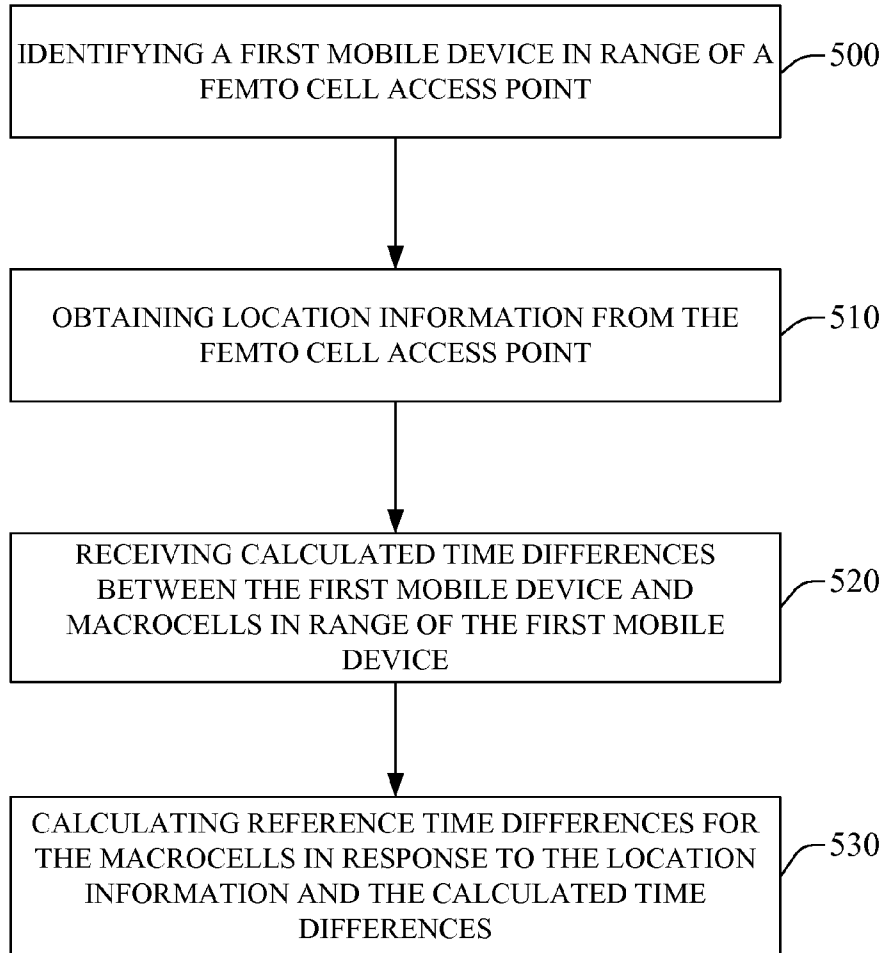

**FIG. 3**

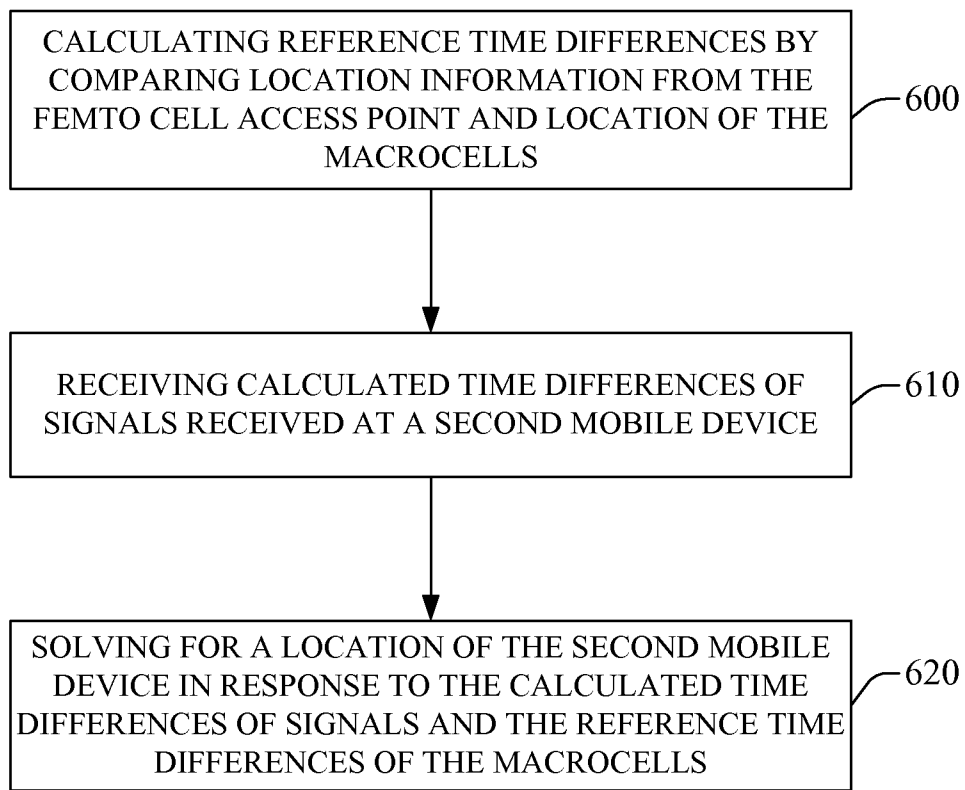



**FIG. 4**



**FIG. 5**



**FIG. 6**

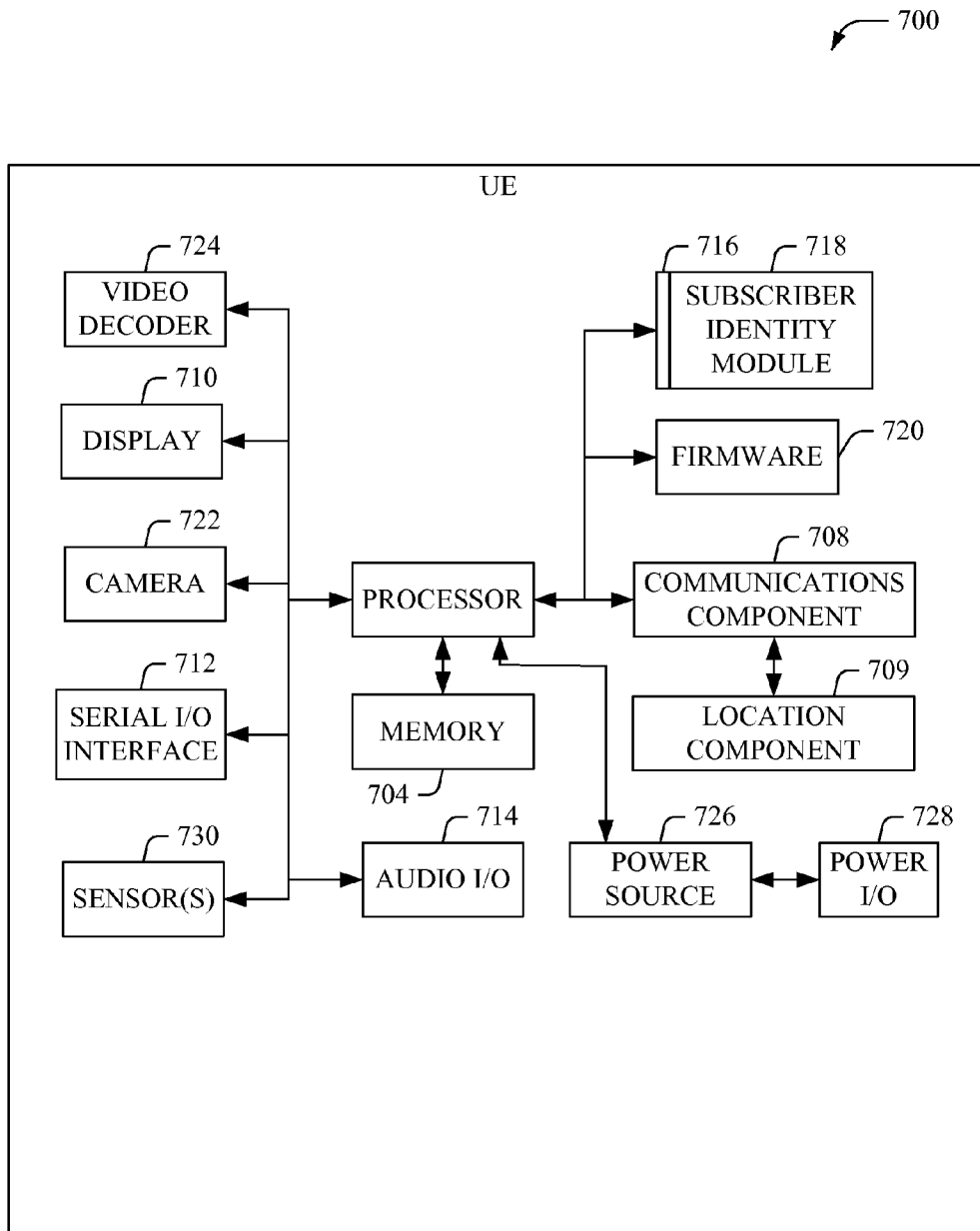

FIG. 7

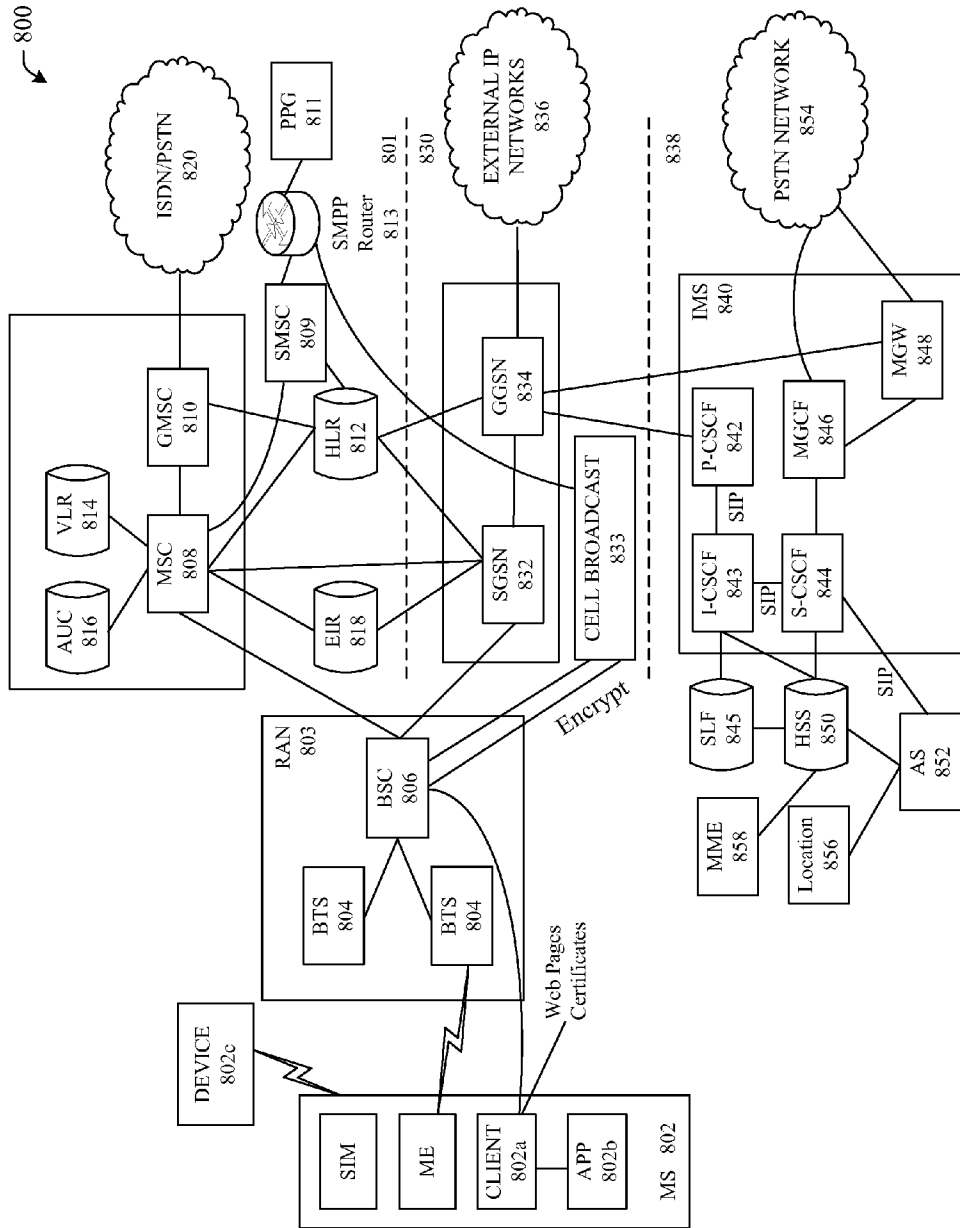

FIG. 8

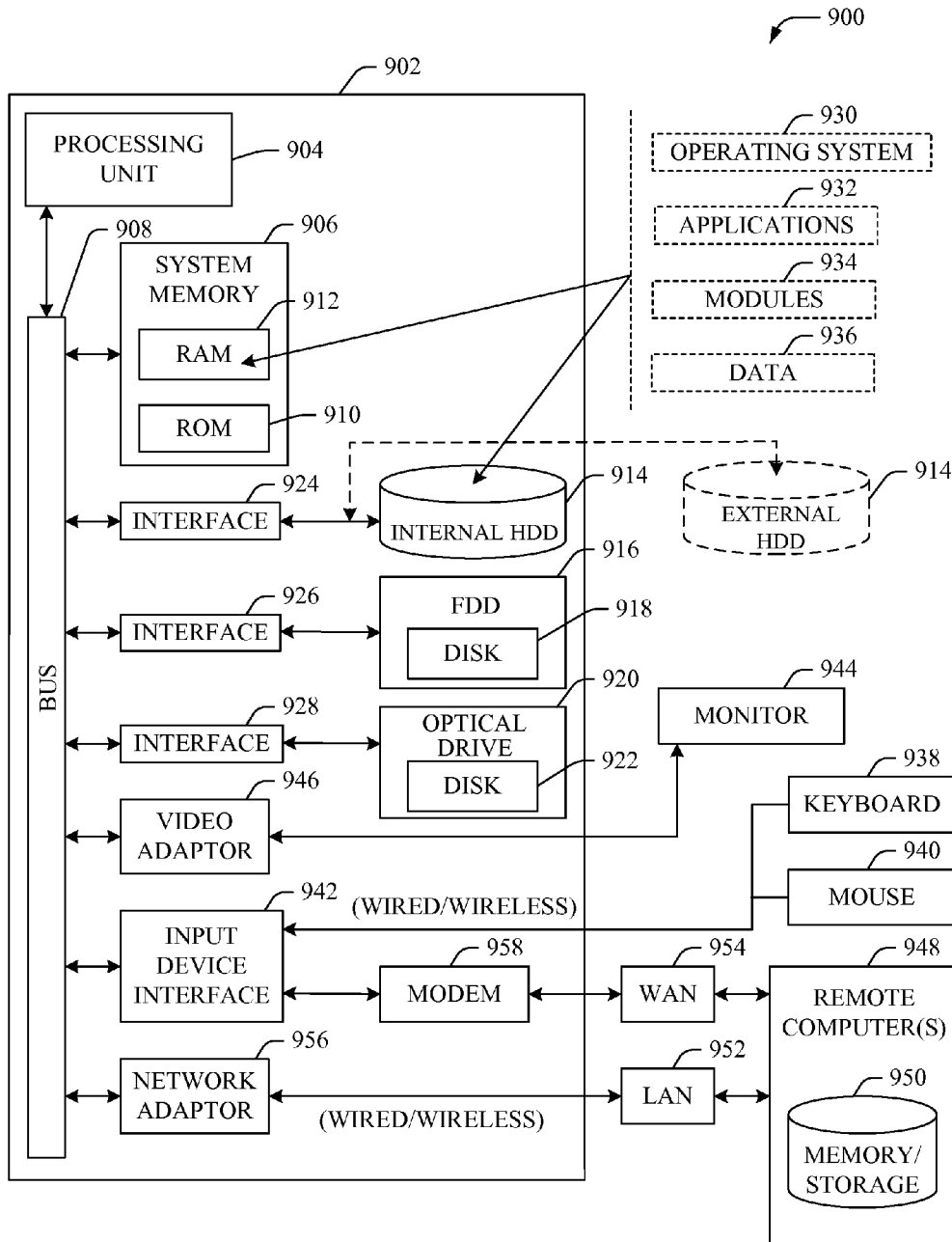

FIG. 9

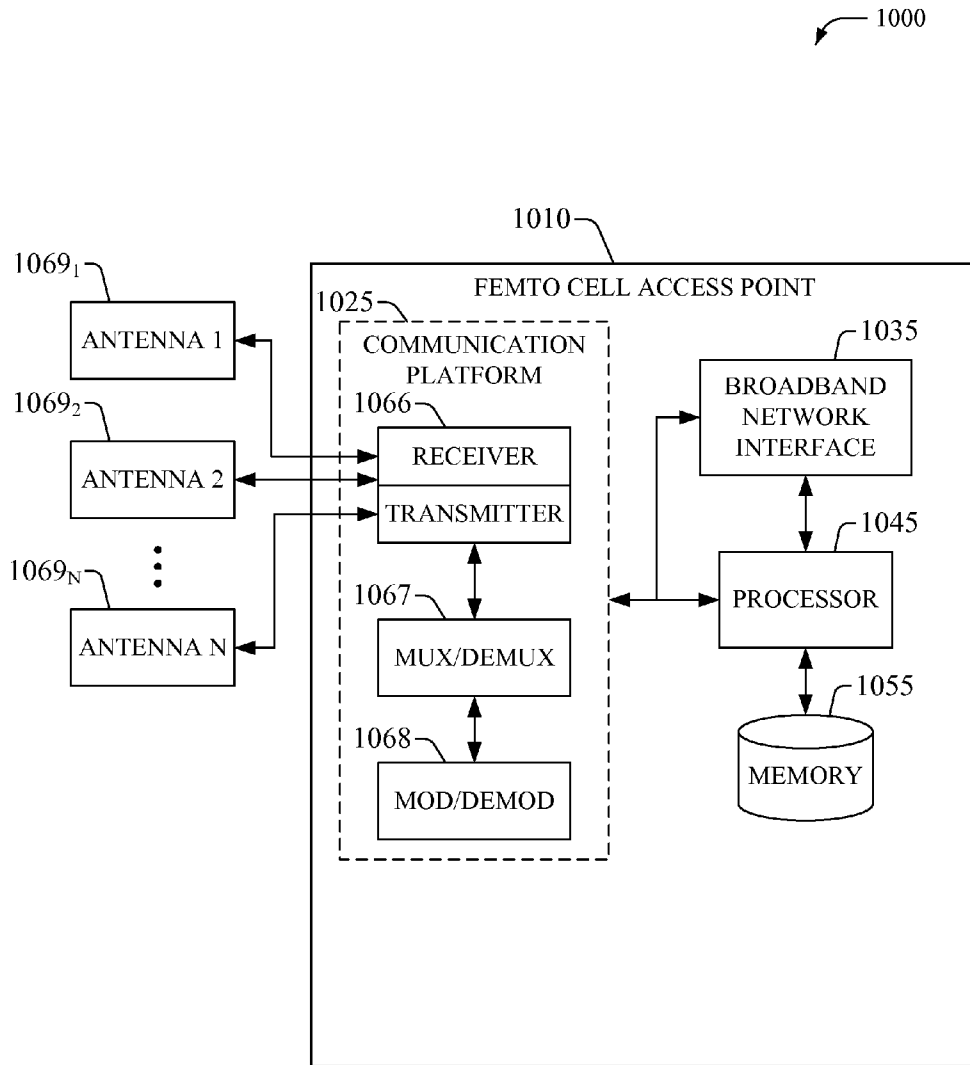

FIG. 10

1

## FEMTOCELL CALIBRATION FOR TIMING BASED LOCATING SYSTEMS

### TECHNICAL FIELD

The subject disclosure relates to wireless communications, and, more particularly, to calibrating timing based locating systems using femtocells in a wireless environment.

### BACKGROUND

Accurately locating mobile devices that are active on a network is beneficial not just to mobile device users, but also to network operators. If the network operators know the precise locations of the mobile devices, many services can be offered that would not otherwise be possible. Such services can include: dynamic provisioning of coupons as mobile device users pass in front of retail stores; marketing; analyzing traffic flow and routes; and analyzing network performance issues. Network performance issues can include poor coverage areas and dropped calls. Knowing the precise location of where network performance issues are occurring can be beneficial in troubleshooting and solving the issues.

### SUMMARY

The following presents a simplified summary of the specification in order to provide a basic understanding of some aspects of the specification. This summary is not an extensive overview of the specification. It is intended to neither identify key or critical elements of the specification nor delineate any scope particular embodiments of the specification, or any scope of the claims. Its sole purpose is to present some concepts of the specification in a simplified form as a prelude to the more detailed description that is presented later. It will also be appreciated that the detailed description may include additional or alternative embodiments beyond those described in this summary.

In various non-limiting embodiments, systems and methods are provided to calibrate timing measurements from macrocells to locate mobile devices more accurately. In an example embodiment, a method comprises identifying a first mobile device in range of a femtocell access point and obtaining location information from the femtocell access point. The method can also include receiving calculated time differences of signals between the first mobile device and macrocells in range of the first mobile device and calculating a reference time difference for the macrocells using the location information and the calculated time differences. The method can also include receiving calculated time differences of signals received at a second mobile device and solving for a location of the second mobile device in response to the calculated time differences of signals and the reference time difference of the macrocells.

In another example embodiment, a system can comprise an identification component configured to determine that a first mobile device is within range of a femtocell access point. The system can also comprise a collection component that can be configured to obtain location information from the femtocell access point and the calculated time differences between the first mobile device and macrocells in range of the first mobile device. The system can also comprise a calibration component configured to calculate a reference time difference for the macrocells using the calculated time differences and the location information. The collection component can also be configured to collect calculated time differences of signals between a second mobile device and the macrocells, and a

2

location component can be configured to determine a location of the second mobile device in response to the calculated time differences of signals for the second mobile device and the reference time differences.

The following description and the annexed drawings set forth certain illustrative aspects of the specification. These aspects are indicative, however, of but a few of the various ways in which the principles of the specification may be employed. Other novel features of the specification will become apparent from the following detailed description of the specification when considered in conjunction with the drawings.

### BRIEF DESCRIPTION OF THE DRAWINGS

Various non-limiting embodiments are further described with reference to the accompanying drawings in which:

FIG. 1 illustrates an example, non-limiting embodiment of a system that can facilitate measuring calculated time differences at a known location in accordance with the subject disclosure.

FIG. 2 illustrates an example, non-limiting embodiment of a system that can calibrate timing based location solutions and create a reference time difference in accordance with the subject disclosure.

FIG. 3 illustrates an example, non-limiting embodiment of a system that can measure calculated time differences at a mobile device in accordance with the subject disclosure.

FIG. 4 illustrates an example, non-limiting embodiment of a system that can locate a mobile device in accordance with the subject disclosure.

FIG. 5 illustrates an example, non-limiting method for calibrating timing based location systems in accordance with the subject disclosure.

FIG. 6 illustrates an example, non-limiting method for locating mobile devices in accordance with the subject disclosure.

FIG. 7 illustrates a block diagram of a User Equipment (UE) suitable for collecting and reporting calculated time differences in accordance with the subject disclosure.

FIG. 8 illustrates a Global System for Mobile Communications (GSM)/General Packet Radio Service (GPRS)/Internet protocol (IP) multimedia network architecture that can employ the disclosed architecture.

FIG. 9 illustrates a block diagram of a computer operable to execute the disclosed communication architecture.

FIG. 10 illustrates an example embodiment of a femtocell access point that can report location information in accordance with the subject disclosure.

### DETAILED DESCRIPTION

One or more embodiments are now described with reference to the drawings, wherein like reference numerals are used to refer to like elements throughout. In the following description, for purposes of explanation, numerous specific details are set forth in order to provide a thorough understanding of the various embodiments. It may be evident, however, that the various embodiments can be practiced without these specific details, e.g., without applying to any particular networked environment or standard. In other instances, well-known structures and devices are shown in block diagram form in order to facilitate describing the embodiments in additional detail.

Further, the various embodiments can be implemented as a method, apparatus, or article of manufacture using standard programming and/or engineering techniques to produce soft-



ware, firmware, hardware, or any combination thereof to control a computer to implement one or more aspects of the disclosed subject matter. An article of manufacture can encompass a computer program accessible from any computer-readable device or computer-readable storage/communications media. For example, computer readable storage media can include but are not limited to magnetic storage devices (e.g., hard disk, floppy disk, magnetic strips . . . ), optical disks (e.g., compact disk (CD), digital versatile disk (DVD) . . . ), smart cards, and flash memory devices (e.g., card, stick, key drive . . . ). Of course, those skilled in the art will recognize many modifications can be made to this configuration without departing from the scope or spirit of the various embodiments.

In addition, the word “example” and/or “exemplary” is used herein to mean serving as an example, instance, or illustration. Any aspect or design described herein as “example” and/or “exemplary” is not necessarily construed as preferred or advantageous over other aspects or designs. Rather, use of the word exemplary is intended to present concepts in a concrete fashion. As used in this application, the term “or” is intended to mean an inclusive “or” rather than an exclusive “or”. That is, unless specified otherwise, or clear from context, “X employs A or B” is intended to mean any of the natural inclusive permutations. That is, if X employs A; X employs B; or X employs both A and B, then “X employs A or B” is satisfied under any of the foregoing instances. In addition, the articles “a” and “an” as used in this application and the appended claims should generally be construed to mean “one or more” unless specified otherwise or clear from context to be directed to a singular form.

Moreover, terms like “user equipment,” “mobile station,” “mobile,” “subscriber station,” “access terminal,” “terminal,” “handset,” “mobile device,” and similar terminology, refer to a wireless device utilized by a subscriber or user of a wireless communication service to receive or convey data, control, voice, video, sound, gaming, or substantially any data-stream or signaling-stream. The foregoing terms are utilized interchangeably in the subject specification and related drawings. Likewise, the terms “access point,” “base station,” “Node B,” and the like, are utilized interchangeably in the subject application, and refer to a wireless network component or appliance that serves and receives data, control, voice, video, sound, gaming, or substantially any data-stream or signaling-stream from a set of subscriber stations. Data and signaling streams can be packetized or frame-based flows.

Furthermore, the terms “user,” “subscriber,” “customer,” and the like are employed interchangeably throughout the subject specification, unless context warrants particular distinction(s) among the terms. It should be appreciated that such terms can refer to human entities or automated components supported through artificial intelligence (e.g., a capacity to make inference based on complex mathematical formalisms), which can provide simulated vision, sound recognition and so forth. In addition, the terms “data flow,” “data session,” and the like are also employed interchangeably throughout the subject specification, unless context warrants particular distinction(s) among the terms.

The systems and methods disclosed herein can implement a femtocell calibration solution that uses the known location of the femtocell to calibrate timing based locating systems. The calculated time differences of different signals sent between macrocells and a mobile device can be used to solve for a reference time difference that accounts for the timing differences of the unsynchronized macrocells. The reference time difference can then be used to solve for the location of another mobile device if the calculated time differences

between that mobile device and the macrocells are known. The solution can include taking many measurements of the calculated time difference at the first mobile device in order to average them to get a more accurate reference time difference. The solution can further include ceasing measurements at the first mobile device when the mobile device is no longer within range of the femtocell.

Aspects or features of the subject innovation can be exploited in substantially any wireless communication technology; e.g., Universal Mobile Telecommunications System (UMTS), Code division multiple access (CDMA), Wi-Fi, Worldwide Interoperability for Microwave Access (WiMAX), General Packet Radio Service (GPRS), Enhanced GPRS, Third Generation Partnership Project (3GPP) Long Term Evolution (LTE), Third Generation Partnership Project 2 (3GPP2) Ultra Mobile Broadband (UMB), High Speed Packet Access (HSPA), Evolved High Speed Packet Access (HSPA+), High-Speed Downlink Packet Access (HSDPA), High-Speed Uplink Packet Access (HSUPA), Zigbee, or another IEEE 802.XX technology. Additionally, substantially all aspects of the subject innovation can be exploited in legacy telecommunication technologies.

Turning now to FIG. 1, there is illustrated an example, non-limiting system **100** that can facilitate measuring calculated time differences at a known location in accordance with the subject disclosure. Included in system **100** is a femtocell access point **102** that can be configured to provide a known location. Femtocell access point **102** can also be configured to detect when mobile device **104** is in range of the femtocell access point **102**. Macrocells **106**, **108**, and **110** can have overlapping coverage areas **112**, **114**, and **116**. Mobile device **104**, which can be located in an area that is covered by macrocells **106**, **108**, and **110**, can send and receive communication signals from each of the three macrocells.

It is to be appreciated that while FIG. 1 shows mobile device **104** within range of three macrocells, any number of macrocells is possible depending on the physical location. In some geographic locations, the number of macrocells could be as high as 10-15. Additionally, it is also to be appreciated that the reference to “macrocells” as used herein is an example of a cellular base station. A person of ordinary skill in the art would appreciate that any suitable cellular base station with a range of transmitting powers, including, but not limited to microcells and picocells could be employed as well.

Femtocell access point **102** can be configured to detect when mobile device **104** is within range of the femtocell access point **102**. Femtocells can have a limited range, perhaps approximately 10-12 m in accordance with an example embodiment. Femtocell access point **102** can determine that mobile device **104** is near when it can transmit to and receive a signal from mobile device **104**.

Macrocells **106**, **108**, and **110**, can be configured to send out regular signals that can be received by mobile devices in range of macrocells. The signals can be received and processed by the mobile devices independent of a call. In this way, the network based locating system can operate using network overhead resources that can be cheaper and less resource intensive than communications sent over an application layer datalink.

The signals can contain code that can identify the macrocell that sent the signal. Each macrocell can have a unique signature, so that the signal can be positively identified as belonging to a specific macrocell. The mobile device **104** can analyze the signals when they are received, and compare the times of receipt. When signals arrive at different times that can indicate that the signals had different distances to travel,

and thus the relative distances of the macrocells can be determined. These time differences are the calculated time differences and there can be an calculated time difference for each macrocell within range of mobile device 104.

In the exemplary system 100 shown in FIG. 1, there can be three calculated time differences for signals sent between macrocells 106, 108, 110, and mobile device 104. Mobile device 104 can report back the calculated time differences in a Radio Resource Control (RRC) measurement report that includes the primary scrambling code of the macrocell, strength of the signal, and the timing measurement. Since macrocells 106, 108, and 110 are unsynchronized however, the calculated time differences, if used in multilateration or triangulation to locate mobile device 104, would yield a result that would be accurate to between +/-200-500 m. However, using the known location of the femtocell access point 102, the calculated time differences can be calibrated (See FIG. 2), to much more accurately locate a mobile device (See FIGS. 3 and 4).

Turning now to FIG. 2, an example, non-limiting embodiment of a system that can calibrate timing based location solutions and create a reference time difference is shown. Included in system 200 is a mobile device 202 that can be provided to receive signals from macrocell 206 and measure the calculated time difference between macrocell 206 and mobile device 202. Femtocell access point 204 can be provided to provide a known location of the mobile device 202 to core network 210. Communications between the femtocell access point 204 and the core network 210 can be facilitated by a femtocell controller 208. Within the core network 210 can be an identification component 212 configured to determine when mobile device 202 is within range of the femtocell access point 204. A collection component 214 can also be provided to collect the location information from the femtocell access point 204, and the calculated time differences from the mobile device 202. A calibration component 216 can be provided to calculate a reference time difference for the macrocell 206 in using the location information and the calculated time differences.

It is to be appreciated that while FIG. 2 shows one macrocell, any number of macrocells is possible. Indeed, collection component 214 can receive from mobile device 202 as many as 10-15 calculated time differences corresponding to as many discrete macrocells.

Femtocell access point 204 can communicate with the femtocell controller 208 over an Iuh interface on a broadband network. The femtocell controller 208 can then forward information to the core network 210 directly.

Identification component 212 can be configured to determine that the mobile device 202 is within range of the femtocell access point 204. Since femtocell access point 204 may have a limited range, perhaps 10-12 m, femtocell access point 204 can receive and transmit signals to and from the mobile device 202 within a defined range around the femtocell access point 204. Femtocell access point 204 can forward a notification that mobile device 202 is present to the core network 210 via the femtocell controller 208. Identification component 212 can receive the notification that mobile device 202 is within range of the femtocell access point 204, and upon receipt of that notification, collection component 214 can begin collecting the calculated time differences from mobile device 202.

The identification component 212 can also receive from the femtocell access point 204 information that identifies the mobile device, such as the IMSI and MSISDN numbers associated with the mobile device, as well as other identifying information.

Collection component 214 can be configured to collect the location information that corresponds to the femtocell access point 204. In one embodiment, the location information can be provided by the femtocell access point 204 via the femtocell controller 208 over the Iuh interface. In this embodiment, the location information can be obtained by a GPS receiver on the femtocell access point 204. The GPS receiver can continuously provide location information, or can provide new location information if the location of the femtocell access point changes.

In another embodiment, the collection component 214 can collect the location information corresponding to the femtocell access point 204 from a known location of the femtocell access point 204 that is in a data store in the core network 210. To collect location information corresponding to the correct femtocell access point, identification component can receive information identifying the femtocell access point 204 via the femtocell controller 208, and use that information to retrieve the correct location of the femtocell access point 204.

Collection component 214 can obtain the calculated time differences from mobile device 202 in the form of an RRC measurement report. The RRC measurement report can include the primary scrambling code of the macrocell, strength of the signal, and the timing measurement. The primary scrambling code can identify the macrocell. Upon determining the identity of macrocell 206, collection component 214 can also obtain the location of macrocell 206 from a data store in the core network.

In one embodiment, collection component 214 can retrieve the RRC measurement report from mobile device 202 via a macrocell, using network overhead resources. In an alternative embodiment, collection component 214 can retrieve the RRC measurement report from mobile device 202 through the Iuh interface on the femtocell access point 204 and via the femtocell controller 208.

Once the location information for the femtocell access point 204 and the macrocells (of which macrocell 206 can be one of many), and the calculated time differences as measured by mobile device 202 have been received by collection component 214, calibration component 216 can calculate a reference time difference used to calibrate the macrocells.

The reference time differences that calibration component 216 can be configured to calculate are a measure of the relative timing differences that different macrocells have with respect to a baseline time. The reference time differences can be used to compensate for the asynchronicities inherent in UMTS and Wideband Code Division Multiple Access (WCDMA) networks so that network based locating systems utilizing calculated time differences will yield more accurate results.

With the known locations of mobile device 202 (e.g., accurate to within the +/-10-12 m range of the femtocell access point 204) and the macrocells, the calibration component 216 can determine the distance between the macrocells and the mobile device. Since signals between the macrocells and mobile device 202 travel at a constant speed  $c$ , the expected time it takes for a signal from each macrocell to arrive at mobile device 202 can be determined. Calibration component 216 can then use the expected time to determine the deviation of the signals from a baseline. This deviation is the reference time difference which can compensate for the asynchronous signals from the macrocells. The reference time differences can then be used to accurately locate another mobile device, shown in more detail in FIGS. 3 and 4.

In an embodiment, collection component 214 can be configured to obtain multiple calculated time differences for the same macrocells over a period of time. Collection component

214 can obtain many calculated time differences between each macrocell and the mobile device 202 for a defined period of time, or continuously. Since the mobile device 202 can move around within the range of the femtocell access point 204, averaging the calculated time differences for each macrocell will obtain a more accurate reference time difference, one that corresponds closer to the actual location of the femtocell access point 204.

The collection component 214 can also collect information that identifies the time at which calculated time differences were obtained, as well as the time at which location information for the femtocell access point 204 was collected. Femtocell access points 204 can be moved, and to calculate reference time differences, the location of the femtocell access point 204 should correspond to calculated time differences measured at that location. Time stamps on the RRC measurement reports and the location information from the femtocell access point ensure that the RRC measurement reports correspond to the location at which the measurement reports were measured.

The identification component 212 can also receive an indication from the femtocell access point 204 via femtocell controller 208 when mobile device 202 is no longer within communication range of femtocell access point 204. Upon receiving this indication, identification component 212 can issue a notification to collection component 214 to stop retrieving the RRC measurement reports from the mobile device 202. When mobile device 202 is outside the range of the femtocell access point 204 inaccurate reference time differences will be obtained.

Turning now to FIG. 3, an example, non-limiting embodiment of a system 300 that can measure calculated time differences at a mobile device is shown. Mobile device 302 can be provided to measure calculated time differences from macrocells 304 and 306. Macrocells 304 and 306 can have overlapping ranges 308 and 310 respectively. Mobile device 302 can measure the calculated time differences between mobile device 302 and whichever macrocell ranges mobile device 302 is located in.

It is to be appreciated that while FIG. 3 shows mobile device 302 within range of two macrocells, any number of macrocells is possible depending on the physical location. In urban, or semi urban areas, the number of macrocells could be as high as 10-15.

Mobile device 302 can be located outside the range of a femtocell access point. Mobile device 302 can have formerly been within range of a femtocell access point, when reference time differences for macrocells 304 and 306 were determined, or mobile device 302 might have never been within range of a femtocell access point, and the reference time differences may have been calculated using calculated time differences from a different mobile device.

Macrocells 304 and 306 can be configured to send out regular signals that can be received by mobile devices in range of macrocells. The signals can be received and processed by the mobile devices independent of a call. In this way, the network based locating system can operate using network overhead resources that can be cheaper and less resource intensive than communications sent over an application layer data link.

The signals can contain code that can identify the macrocell that sent the signal. Each macrocell can have a unique signature, so that the signal can be positively identified as belonging to a particular macrocell. The mobile device 302 can analyze the signals when received, and compare the times of receipt. When signals arrive at different times that can indicate that the signals had different distances to travel, and

thus the relative distances of the macrocells can be determined. These time differences are the calculated time differences and there can be an calculated time difference for each macrocell within range of mobile device 302.

Turning now to FIG. 4, an example, non-limiting embodiment of a system 400 that can locate a mobile device is shown. A mobile device 402 that has determined calculated time differences from macrocells 404 and 406 can forward the calculated time differences to core network 408. Collection component 410 can receive the calculated time differences and the locations of the macrocells 404 and 406, and can forward the information to location component 412. Location component 412 can use the information collected as well as the reference time differences that correspond to the macrocells to determine the location of mobile device 402.

Collection component 410 can obtain the calculated time differences from mobile device 402 in the form of an RRC measurement report. The RRC measurement report can include the primary scrambling code of the macrocell, strength of the signal, and the timing measurement. The primary scrambling code can identify the macrocell. Upon determining the identity of macrocells 404 and 406, collection component 410 can obtain the location of macrocells 404 and 406 from a data store in the core network. Collection component 410 can retrieve the RRC measurement report from mobile device 402 via one of the macrocells, using network overhead resources.

The reference time differences can show the relative signal delay for each of the macrocells. Subtracting the reference time differences from the calculated time differences can yield actual time differences for signals sent between the macrocells and the mobile device 402. With the actual time difference and the known locations of macrocells 404 and 406, it can be possible to use multilateration or hyperbolic positioning which uses time difference on arrival (TDOA) equations to solve for the location of mobile device 402.

Location component 412 can determine the position of any mobile device to within a defined range, perhaps +/-10-12 m, which corresponds to the accuracy in determining the position of the mobile device that was used to calibrate the macrocells—the range of the femtocell access point can be, for example, +/-10-12 m, and the mobile device can be anywhere in that area. During the calibration phase, as more calculated time differences are measured over time and averaged, the position of the mobile device can move nearer the center of the femtocell access point, and the reference time differences can become more accurate, leading to greater than +/-10-12 m accuracy.

FIGS. 5 and 6 illustrate methods and/or flow diagrams in accordance with the disclosed subject matter. For simplicity of explanation, the methods are depicted and described as a series of acts. It is to be understood and appreciated that the subject innovation is not limited by the acts illustrated and/or by the order of acts, for example acts can occur in various orders and/or concurrently, and with other acts not presented and described herein. Furthermore, not all illustrated acts may be required to implement the methods in accordance with the disclosed subject matter. In addition, those skilled in the art will understand and appreciate that the methods could alternatively be represented as a series of interrelated states via a state diagram or events. Additionally, it should be further appreciated that the methods disclosed hereinafter and throughout this specification are capable of being stored on an article of manufacture to facilitate transporting and transferring such methods to computers. The term article of manufacture, as used herein, is intended to encompass a computer

program accessible from any computer-readable device or computer-readable storage/communications media.

Referring now to FIG. 5, illustrated is an example, non-limiting process for calibrating timing based location systems in accordance with the subject disclosure. At 500, a mobile device in range of a femtocell access point can be identified. The femtocell can detect when a mobile device is in range by receiving and transmitting signals between the femtocell and the mobile device. The femtocell access point can send an indication to the core network via an Iuh interface to a femtocell controller on the core network. The femtocell access point can also forward identifying information about the mobile device to the core network, including but not limited to such information as the IMSI and MSISDN numbers associated with the mobile device.

At 510, location information from the femtocell access point can be obtained. In one embodiment, the location information can be provided by the femtocell access point via the femtocell controller over the Iuh interface. In this embodiment, the location information can be obtained by a GPS receiver on the femtocell access point that provides the latitude and longitude of the femtocell access point. The GPS receiver can continuously provide location information, or can provide new location information if the location of the femtocell access point changes.

In another embodiment, the location information can be collected from a known location of the femtocell access point from a data store in the core network. To collect location information corresponding to the correct femtocell, information identifying the femtocell access point can be received, and that information can be used to retrieve the on record location of the femtocell access point.

At 520, calculated time differences between the mobile device and macrocells within range of the mobile device can be received. The macrocells can periodically send out signals that can be received by mobile devices in range of the macrocells. The signals can contain code that can identify the macrocell that sent the signal. Each macrocell can have a unique signature, so that the signal can be positively identified as belonging to a specific macrocell. The mobile device can analyze the signals when they are received, and compare the times of receipt. When signals arrive at different times that can indicate that the signals had different distances to travel, and thus the relative distances of the macrocells can be determined. These time differences are the calculated time differences and there can be an calculated time difference for each macrocell within range of mobile device.

The calculated time differences can be collected in the form of an RRC measurement report. The RRC measurement report can include the primary scrambling code of the macrocell, strength of the signal, and the timing measurement. The primary scrambling code can identify the macrocell. Upon determining the identity of macrocell, the location of macrocell can be retrieved from a data store stored in the core network.

At 530, a reference time difference for each of the macrocells can be calculated using the location of the femtocell access point, the location of the macrocells, and the calculated time difference. The reference time differences are a measure of the relative timing differences that different macrocells have with respect to a baseline time. The reference time differences can be used to compensate for the asynchronicities inherent in UMTS and WCDMA networks so that network based locating systems utilizing calculated time differences will yield results that are more accurate.

With the known locations of mobile device and the macrocells, the distance between the macrocells and the mobile

device can be determined. Since signals between the macrocells and mobile device travel at a constant speed  $c$ , the expected time it takes for a signal from each macrocell to arrive at the mobile device can be determined. The expected time can be compared to the calculated time difference to determine the deviation of the signals from a baseline time. This deviation is the reference time difference, which can compensate for the asynchronous signals from the macrocells. The reference time differences can then be used to locate another mobile device.

Referring now to FIG. 6, illustrated is an example, non-limiting method for locating mobile devices in accordance with the subject disclosure. At 600, a reference time difference can be calculated by comparing location information about the femtocell access point and the macrocells, as well as the calculated time differences. At 610, calculated time differences between the macrocells and another mobile device can be received. At 620 the reference time differences that correspond to the macrocells can be used, as well as the calculated time differences at the other mobile device to solve for a location of the other mobile device. Subtracting the reference time differences from the calculated time differences can yield actual time differences for signals sent between the macrocells and the mobile device. Using the actual time difference with the known locations of macrocells, it can be possible to use the method of multilateration or hyperbolic positioning which uses time difference on arrival (TDOA) equations to solve for the location of mobile device.

Referring now to FIG. 7, there is illustrated a block diagram of a UE 700 in accordance with the innovation. The UE 700 can include a processor 702 for controlling all onboard operations and processes. A memory 704 can interface to the processor 702 for storage of data and one or more applications 706 being executed by the processor 702. A communications component 708 can interface to the processor 702 to facilitate wired/wireless communication with external systems (e.g., femtocell and macro cell). The communications component 708 interfaces to a location component 709 (e.g., GPS transceiver) that can facilitate location detection of the UE 700. Note that the location component 709 can also be included as part of the communications component 708.

The UE 700 can include a display 710 for displaying content downloaded and/or for displaying text information related to operating and using the device features. A serial I/O interface 712 is provided in communication with the processor 702 to facilitate serial communication (e.g., USB, and/or IEEE 1394) via a hardwire connection. Audio capabilities are provided with an audio I/O component 714, which can include a speaker for the output of audio signals related to, for example, recorded data or telephony voice data, and a microphone for inputting voice signals for recording and/or telephone conversations. In addition, sensor(s) 730 can be included to detect usage activity of the UE 700 and/or to detect position, motion and/or orientation of the UE 700.

The UE 700 can include a slot interface 716 for accommodating a subscriber identity module (SIM) 718. Firmware 720 is also provided to store and provide to the processor 702 startup and operational data. The UE 700 can also include an image capture component 722 such as a camera and/or a video decoder 724 for decoding encoded multimedia content. The UE 700 can also include a power source 726 in the form of batteries, which interfaces to an external power system or charging equipment via a power I/O component 728. In addition, the UE 700 can be substantially similar to and include functionality associated with mobile devices 104, 202, 302, and 402 described herein.

Now turning to FIG. 8, such figure depicts an example GSM/GPRS/IP multimedia network architecture **800** that can employ the disclosed communication architecture. In particular, the GSM/GPRS/IP multimedia network architecture **800** includes a GSM core network **801**, a GPRS network **830** and an IP multimedia network **838**. The GSM core network **801** includes a Mobile Station (MS) **802**, at least one Base Transceiver Station (BTS) **804** and a Base Station Controller (BSC) **806**. The MS **802** is physical equipment or Mobile Equipment (ME), such as a mobile phone or a laptop computer that is used by mobile subscribers, with a Subscriber Identity Module (SIM). The SIM includes an International Mobile Subscriber Identity (IMSI), which is a unique identifier of a subscriber. The MS **802** includes an embedded client **802a** that receives and processes messages received by the MS **802**. The embedded client **802a** can be implemented in JAVA or another programming language and is discussed more fully below. It can be appreciated that MS **802** can be substantially similar to mobile devices **104**, **202**, **302**, **402**, and UE **700**, and can include functionality described with respect to mobile devices **104**, **202**, **302**, and **402** in systems **100-400** and **700**.

The embedded client **802a** communicates with an application **802b** (e.g., application(s) **202**) that provides services and/or information to an end user. Additionally or alternately, the MS **802** and a device **802c** can be enabled to communicate via a short-range wireless communication link, such as BLUETOOTH®. As one of ordinary skill in the art would recognize, there can be an endless number of devices **802c** that use the SIM within the MS **802** to provide services, information, data, audio, video, etc. to end users.

The BTS **804** is physical equipment, such as a radio tower, that enables a radio interface to communicate with the MS **802**. Each BTS can serve more than one MS. The BSC **806** manages radio resources, including the BTS. Moreover, the BSC **806** can be substantially similar to macrocells **106**, **108**, and **110** and etc., disclosed herein. The BSC and BTS components, in combination, are generally referred to as a base station (BSS) or radio access network (RAN) **803**.

The GSM core network **801** also includes a Mobile Switching Center (MSC) **808**, a Gateway Mobile Switching Center (GMSC) **810**, a Home Location Register (HLR) **812**, Visitor Location Register (VLR) **814**, an Authentication Center (AuC) **816**, and an Equipment Identity Register (EIR) **818**. The MSC **808** performs a switching function for the network. The MSC also performs other functions, such as registration, authentication, location updating, handovers, and call routing. The GMSC **810** provides a gateway between the GSM network and other networks, such as an Integrated Services Digital Network (ISDN) or Public Switched Telephone Networks (PSTNs) **820**. In other words, the GMSC **810** provides interworking functionality with external networks.

The HLR **812** is a database or component(s) that comprises administrative information regarding each subscriber registered in a corresponding GSM network. The HLR **812** also includes the current location of each MS. The VLR **814** is a database or component(s) that contains selected administrative information from the HLR **812**. The VLR contains information necessary for call control and provision of subscribed services for each MS currently located in a geographical area controlled by the VLR. The HLR **812** and the VLR **814**, together with the MSC **808**, provide the call routing and roaming capabilities of GSM. The AuC **816** provides the parameters needed for authentication and encryption functions. Such parameters allow verification of a subscriber's identity. The EIR **818** stores security-sensitive information about the mobile equipment.

A Short Message Service Center (SMSC) **809** allows one-to-one Short Message Service (SMS) messages to be sent to/from the MS **802**. A Push Proxy Gateway (PPG) **811** is used to "push" (e.g., send without a synchronous request) content to the MS **802**. The PPG **811** acts as a proxy between wired and wireless networks to facilitate pushing of data to the MS **802**. A Short Message Peer to Peer (SMPP) protocol router **813** is provided to convert SMS-based SMPP messages to cell broadcast messages. SMPP is a protocol for exchanging SMS messages between SMS peer entities such as short message service centers. It is often used to allow third parties, e.g., content suppliers such as news organizations, to submit bulk messages.

To gain access to GSM services, such as speech, data, and short message service (SMS), the MS first registers with the network to indicate its current location by performing a location update and IMSI attach procedure. The MS **802** sends a location update including its current location information to the MSC/VLR, via the BTS **804** and the BSC **806**. The location information is then sent to the MS's HLR. The HLR is updated with the location information received from the MSC/VLR. The location update also is performed when the MS moves to a new location area. In one aspect, the location update is periodically performed to update the database as location-updating events occur.

The GPRS network **830** is logically implemented on the GSM core network architecture by introducing two packet-switching network nodes, a serving GPRS support node (SGSN) **832**, a cell broadcast and a Gateway GPRS support node (GGSN) **834**. The SGSN **832** is at the same hierarchical level as the MSC **808** in the GSM network. The SGSN controls the connection between the GPRS network and the MS **802**. The SGSN also keeps track of individual MS's locations, security functions, and access controls.

A Cell Broadcast Center (CBC) **833** communicates cell broadcast messages that are typically delivered to multiple users in a specified area. Cell Broadcast is one-to-many geographically focused service. It enables messages to be communicated to multiple mobile phone customers who are located within a given part of its network coverage area at the time the message is broadcast.

The GGSN **834** provides a gateway between the GPRS network and a public packet network (PDN) or other IP networks **836**. That is, the GGSN provides interworking functionality with external networks, and sets up a logical link to the MS through the SGSN. When packet-switched data leaves the GPRS network, it is transferred to an external TCP-IP network **836**, such as an X.25 network or the Internet. In order to access GPRS services, the MS first attaches itself to the GPRS network by performing an attach procedure. The MS then activates a packet data protocol (PDP) context, thus activating a packet communication session between the MS, the SGSN, and the GGSN. In a GSM/GPRS network, GPRS services and GSM services can be used in parallel. A GPRS network **830** can be designed to operate in three network operation modes (NOM1, NOM2 and NOM3). A network operation mode of a GPRS network is indicated by a parameter in system information messages transmitted within a cell. The system information messages dictates a MS where to listen for paging messages and how signal towards the network. The network operation mode represents the capabilities of the GPRS network.

The IP multimedia network **838** was introduced with 3GPP Release 5, and includes an IP multimedia subsystem (IMS) **840** to provide rich multimedia services to end users. A representative set of the network entities within the IMS **840** are a call/session control function (CSCF), a media gateway con-

trol function (MGCF) **846**, a media gateway (MGW) **848**, and a master subscriber database, called a home subscriber server (HSS) **850**. The HSS **850** can be common to the GSM network **801**, the GPRS network **830** as well as the IP multimedia network **838**.

The IP multimedia system **840** is built around the call/session control function, of which there are three types: an interrogating CSCF (I-CSCF) **843**, a proxy CSCF (P-CSCF) **842**, and a serving CSCF (S-CSCF) **844**. The P-CSCF **842** is the MS's first point of contact with the IMS **840**. The P-CSCF **842** forwards session initiation protocol (SIP) messages received from the MS to an SIP server in a home network (and vice versa) of the MS. The P-CSCF **842** can also modify an outgoing request according to a set of rules defined by the network operator (for example, address analysis and potential modification).

The I-CSCF **843** forms an entrance to a home network and hides the inner topology of the home network from other networks and provides flexibility for selecting an S-CSCF. The I-CSCF **843** can contact a subscriber location function (SLF) **845** to determine which HSS **850** to use for the particular subscriber, if multiple HSS's **850** are present. The S-CSCF **844** performs the session control services for the MS **802**. This includes routing originating sessions to external networks and routing terminating sessions to visited networks. The S-CSCF **844** also decides whether an application server (AS) **852** is required to receive information on an incoming SIP session request to ensure appropriate service handling. This decision is based on information received from the HSS **850** (or other sources, such as an application server **852**). The AS **852** also communicates to a location server **856** (e.g., a Gateway Mobile Location Center (GMLC)) that provides a position (e.g., latitude/longitude coordinates) of the MS **802**. The mobility management entity (MME) **858** provides authentication of a user by interacting with the HSS **850** in LTE networks.

The HSS **850** contains a subscriber profile and keeps track of which core network node is currently handling the subscriber. It also supports subscriber authentication and authorization functions (AAA). In networks with more than one HSS **850**, a subscriber location function provides information on the HSS **850** that contains the profile of a given subscriber.

The MGCF **846** provides interworking functionality between SIP session control signaling from the IMS **840** and ISUP/BICC call control signaling from the external GSTN networks (not shown). It also controls the media gateway (MGW) **848** that provides user-plane interworking functionality (e.g., converting between AMR- and PCM-coded voice). The MGW **848** also communicates with a PSTN network **854** for TDM trunks. In addition, the MGCF **846** communicates with the PSTN network **854** for SS7 links.

Referring now to FIG. 9, there is illustrated a block diagram of a computer operable to execute the disclosed communication architecture. In order to provide additional context for various aspects of the subject specification, FIG. 9 and the following discussion are intended to provide a brief, general description of a suitable computing environment **900** in which the various aspects of the specification can be implemented. While the specification has been described above in the general context of computer-executable instructions that can run on one or more computers, those skilled in the art will recognize that the specification also can be implemented in combination with other program modules and/or as a combination of hardware and software.

Program modules can include routines, programs, components, data structures, etc., that perform particular tasks or implement particular abstract data types. Moreover, those

skilled in the art will appreciate that the inventive methods can be practiced with other computer system configurations, including single-processor or multiprocessor computer systems, minicomputers, mainframe computers, as well as personal computers, hand-held computing devices, microprocessor-based or programmable consumer electronics, and the like, each of which can be operatively coupled to one or more associated devices.

The illustrated aspects of the specification can also be practiced in distributed computing environments where certain tasks are performed by remote processing devices that are linked through a communications network. In a distributed computing environment, program modules can be located in both local and remote memory storage devices.

Computing devices can include a variety of media, which can include computer-readable storage media and/or communications media, which two terms are used herein differently from one another as follows. Computer-readable storage media can be any available storage media that can be accessed by the computer and includes both volatile and nonvolatile media, removable and non-removable media. By way of example, and not limitation, computer-readable storage media can be implemented in connection with any method or technology for storage of information such as computer-readable instructions, program modules, structured data, or unstructured data. Computer-readable storage media can include, but are not limited to, RAM, ROM, EEPROM, flash memory or other memory technology, CD-ROM, digital versatile disk (DVD) or other optical disk storage, magnetic cassettes, magnetic tape, magnetic disk storage or other magnetic storage devices, or other tangible and/or non-transitory media which can be used to store desired information. Computer-readable storage media can be accessed by one or more local or remote computing devices, e.g., via access requests, queries or other data retrieval protocols, for a variety of operations with respect to the information stored by the medium.

Communications media can embody computer-readable instructions, data structures, program modules or other structured or unstructured data in a data signal such as a modulated data signal, e.g., a carrier wave or other transport mechanism, and includes any information delivery or transport media. The term "modulated data signal" or signals refers to a signal that has one or more of its characteristics set or changed in such a manner as to encode information in one or more signals. By way of example, and not limitation, communication media include wired media, such as a wired network or direct-wired connection, and wireless media such as acoustic, RF, infrared and other wireless media.

With reference again to FIG. 9, the example environment **900** for implementing various aspects of the specification includes a computer **902**, the computer **902** including a processing unit **904**, a system memory **906** and a system bus **908**. The system bus **908** couples system components including, but not limited to, the system memory **906** to the processing unit **904**. The processing unit **904** can be any of various commercially available processors. Dual microprocessors and other multi-processor architectures can also be employed as the processing unit **904**.

The system bus **908** can be any of several types of bus structure that can further interconnect to a memory bus (with or without a memory controller), a peripheral bus, and a local bus using any of a variety of commercially available bus architectures. The system memory **906** includes read-only memory (ROM) **910** and random access memory (RAM) **912**. A basic input/output system (BIOS) is stored in a non-volatile memory **910** such as ROM, EPROM, EEPROM, which BIOS contains the basic routines that help to transfer

information between elements within the computer **902**, such as during startup. The RAM **912** can also include a high-speed RAM such as static RAM for caching data.

The computer **902** further includes an internal hard disk drive (HDD) **914** (e.g., EIDE, SATA), which internal hard disk drive **914** can also be configured for external use in a suitable chassis (not shown), a magnetic floppy disk drive (FDD) **916**, (e.g., to read from or write to a removable diskette **918**) and an optical disk drive **920**, (e.g., reading a CD-ROM disk **922** or, to read from or write to other high capacity optical media such as the DVD). The hard disk drive **914**, magnetic disk drive **916** and optical disk drive **920** can be connected to the system bus **908** by a hard disk drive interface **924**, a magnetic disk drive interface **926** and an optical drive interface **928**, respectively. The interface **924** for external drive implementations includes at least one or both of Universal Serial Bus (USB) and IEEE 1394 interface technologies. Other external drive connection technologies are within contemplation of the subject specification.

The drives and their associated computer-readable storage media provide nonvolatile storage of data, data structures, computer-executable instructions, and so forth. For the computer **902**, the drives and storage media accommodate the storage of any data in a suitable digital format. Although the description of computer-readable storage media above refers to a HDD, a removable magnetic diskette, and a removable optical media such as a CD or DVD, it should be appreciated by those skilled in the art that other types of storage media which are readable by a computer, such as zip drives, magnetic cassettes, flash memory cards, cartridges, and the like, can also be used in the example operating environment, and further, that any such storage media can contain computer-executable instructions for performing the methods of the specification.

A number of program modules can be stored in the drives and RAM **912**, including an operating system **930**, one or more application programs **932**, other program modules **934** and program data **936**. All or portions of the operating system, applications, modules, and/or data can also be cached in the RAM **912**. It is appreciated that the specification can be implemented with various commercially available operating systems or combinations of operating systems.

A user can enter commands and information into the computer **902** through one or more wired/wireless input devices, e.g., a keyboard **938** and a pointing device, such as a mouse **940**. Other input devices (not shown) can include a microphone, an IR remote control, a joystick, a game pad, a stylus pen, touch screen, or the like. These and other input devices are often connected to the processing unit **904** through an input device interface **942** that is coupled to the system bus **908**, but can be connected by other interfaces, such as a parallel port, an IEEE 1394 serial port, a game port, a USB port, an IR interface, etc.

A monitor **944** or other type of display device is also connected to the system bus **908** via an interface, such as a video adapter **946**. In addition to the monitor **944**, a computer can include other peripheral output devices (not shown), such as speakers, printers, etc.

The computer **902** can operate in a networked environment using logical connections via wired and/or wireless communications to one or more remote computers, such as a remote computer(s) **948**. The remote computer(s) **948** can be a workstation, a server computer, a router, a personal computer, portable computer, microprocessor-based entertainment appliance, a peer device or other common network node, and can include many or all of the elements described relative to the computer **902**, although, for purposes of brevity, only a

memory/storage device **950** is illustrated. The logical connections depicted include wired/wireless connectivity to a local area network (LAN) **952** and/or larger networks, e.g., a wide area network (WAN) **954**. Such LAN and WAN networking environments are commonplace in offices and companies, and facilitate enterprise-wide computer networks, such as intranets, all of which can connect to a global communications network, e.g., the Internet.

When used in a LAN networking environment, the computer **902** is connected to the local network **952** through a wired and/or wireless communication network interface or adapter **956**. The adapter **956** can facilitate wired or wireless communication to the LAN **952**, which can also include a wireless access point disposed thereon for communicating with the wireless adapter **956**.

When used in a WAN networking environment, the computer **902** can include a modem **958**, or is connected to a communications server on the WAN **954**, or has other means for establishing communications over the WAN **954**, such as by way of the Internet. The modem **958**, which can be internal or external and a wired or wireless device, is connected to the system bus **908** via the serial port interface **942**. In a networked environment, program modules depicted relative to the computer **902**, or portions thereof, can be stored in the remote memory/storage device **950**. It will be appreciated that the network connections shown are example and other means of establishing a communications link between the computers can be used.

The computer **902** is operable to communicate with any wireless devices or entities operatively disposed in wireless communication, e.g., a printer, scanner, desktop and/or portable computer, portable data assistant, communications satellite, any piece of equipment or location associated with a wirelessly detectable tag (e.g., a kiosk, news stand, restroom), and telephone. In an example embodiment, wireless communications can be facilitated, for example, using Wi-Fi, Bluetooth™, Zigbee, and other 802.XX wireless technologies. Thus, the communication can be a predefined structure as with a conventional network or simply an ad hoc communication between at least two devices.

Wi-Fi, or Wireless Fidelity, allows connection to the Internet from a couch at home, a bed in a hotel room, or a conference room at work, without wires. Wi-Fi is a wireless technology similar to that used in a cell phone that enables such devices, e.g., computers, to send and receive data indoors and out; anywhere within the range of a base station. Wi-Fi networks use radio technologies called IEEE 802.11(a, b, g, n etc.) to provide secure, reliable, fast wireless connectivity. A Wi-Fi network can be used to connect computers to each other, to the Internet, and to wired networks (which use IEEE 802.3 or Ethernet). Wi-Fi networks can operate in the unlicensed 2.4 and 5 GHz radio bands, at an 11 Mbps (802.11a), 54 Mbps (802.11b), or 150 Mbps (802.11n) data rate, for example, or with products that contain both bands (dual band), so the networks can provide real-world performance similar to wired Ethernet networks used in many homes and offices.

With respect to FIG. 10, in example embodiment **1000**, femtocell AP **1010** can receive and transmit signal(s) (e.g., traffic and control signals) from and to wireless devices, access terminals, wireless ports and routers, etc., through a set of antennas **1069<sub>1</sub>-1069<sub>N</sub>**. It should be appreciated that while antennas **1069<sub>1</sub>-1069<sub>N</sub>** are a part of communication platform **1025**, which comprises electronic components and associated circuitry that provides for processing and manipulating of received signal(s) (e.g., a packet flow) and signal(s) (e.g., a broadcast control channel) to be transmitted. In an aspect,

communication platform **1025** includes a transmitter/receiver (e.g., a transceiver) **1066** that can convert signal(s) from analog format to digital format upon reception, and from digital format to analog format upon transmission. In addition, receiver/transmitter **1066** can divide a single data stream into multiple, parallel data streams, or perform the reciprocal operation. Coupled to transceiver **1066** is a multiplexer/demultiplexer **1067** that facilitates manipulation of signal in time and frequency space. Electronic component **1067** can multiplex information (data/traffic and control/signaling) according to various multiplexing schemes such as time division multiplexing (TDM), frequency division multiplexing (FDM), orthogonal frequency division multiplexing (OFDM), code division multiplexing (CDM), space division multiplexing (SDM). In addition, mux/demux component **1067** can scramble and spread information (e.g., codes) according to substantially any code known in the art; e.g., Hadamard-Walsh codes, Baker codes, Kasami codes, polyphase codes, and so on. A modulator/demodulator **1068** is also a part of operational group **1025**, and can modulate information according to multiple modulation techniques, such as frequency modulation, amplitude modulation (e.g., M-ary quadrature amplitude modulation (QAM), with M a positive integer), phase-shift keying (PSK), and the like.

FAP **1010** also includes a processor **1045** configured to confer functionality, at least partially, to substantially any electronic component in the femto access point **1010**, in accordance with aspects of the subject disclosure. In particular, processor **1045** can facilitate FAP **1010** to implement configuration instructions received through communication platform **1025**, which can include storing data in memory **1055**. In addition, processor **1045** facilitates FAP **1010** to process data (e.g., symbols, bits, or chips) for multiplexing/demultiplexing, such as effecting direct and inverse fast Fourier transforms, selection of modulation rates, selection of data packet formats, inter-packet times, etc. Moreover, processor **1045** can manipulate antennas **1069<sub>1</sub>-1069<sub>N</sub>** to facilitate beamforming or selective radiation pattern formation, which can benefit specific locations (e.g., basement, home office . . . ) covered by FAP; and exploit substantially any other advantages associated with smart-antenna technology. Memory **1055** can store data structures, code instructions, system or device information like device identification codes (e.g., IMEI, MSISDN, serial number . . . ) and specification such as multimode capabilities; code sequences for scrambling; spreading and pilot transmission, floor plan configuration, access point deployment and frequency plans; and so on. Moreover, memory **1055** can store configuration information such as schedules and policies; FAP address(es) or geographical indicator(s); access lists (e.g., white lists); license (s) for utilization of add-features for FAP **1010**, and so forth. In one example, data store **206** can be implemented in memory **1055**.

In embodiment **1000**, processor **1045** is coupled to the memory **1055** in order to store and retrieve information necessary to operate and/or confer functionality to communication platform **1025**, broadband network interface **1035** (e.g., a broadband modem), and other operational components (e.g., multimode chipset(s), power supply sources, . . . , not shown) that support femto access point **1010**.

As it employed in the subject specification, the term “processor” can refer to substantially any computing processing unit or device comprising, but not limited to comprising, single-core processors; single-processors with software multithread execution capability; multi-core processors; multi-core processors with software multithread execution capability; multi-core processors with hardware multithread

technology; parallel platforms; and parallel platforms with distributed shared memory. Additionally, a processor can refer to an integrated circuit, an application specific integrated circuit (ASIC), a digital signal processor (DSP), a field programmable gate array (FPGA), a programmable logic controller (PLC), a complex programmable logic device (CPLD), a discrete gate or transistor logic, discrete hardware components, or any combination thereof designed to perform the functions described herein. Processors can exploit nanoscale architectures such as, but not limited to, molecular and quantum-dot based transistors, switches and gates, in order to optimize space usage or enhance performance of user equipment. A processor may also be implemented as a combination of computing processing units.

As used in this application, the terms “component,” “system,” “interface,” or the like are generally intended to refer to a computer-related entity, either hardware, a combination of hardware and software, software, or software in execution or an entity related to an operational machine with one or more specific functionalities. For example, a component may be, but is not limited to being, a process running on a processor, a processor, an object, an executable, a thread of execution, a program, and/or a computer. By way of illustration, both an application running on a controller and the controller can be a component. One or more components may reside within a process and/or thread of execution and a component may be localized on one computer and/or distributed between two or more computers. As another example, an interface can include I/O components as well as associated processor, application, and/or API components.

In the subject specification, terms such as “data store,” “data storage,” “database,” “cache,” and substantially any other information storage component relevant to operation and functionality of a component, refer to “memory components,” or entities embodied in a “memory” or components comprising the memory. It will be appreciated that the memory components, or computer-readable storage media, described herein can be either volatile memory or nonvolatile memory, or can include both volatile and nonvolatile memory. By way of illustration, and not limitation, nonvolatile memory can include read only memory (ROM), programmable ROM (PROM), electrically programmable ROM (EPROM), electrically erasable ROM (EEPROM), or flash memory. Volatile memory can include random access memory (RAM), which acts as external cache memory. By way of illustration and not limitation, RAM is available in many forms such as synchronous RAM (SRAM), dynamic RAM (DRAM), synchronous DRAM (SDRAM), double data rate SDRAM (DDR SDRAM), enhanced SDRAM (ESDRAM), Synchronlink DRAM (SLDRAM), and direct Rambus RAM (DRRAM). Additionally, the disclosed memory components of systems or methods herein are intended to comprise, without being limited to comprising, these and any other suitable types of memory.

What has been described above includes examples of the present specification. It is, of course, not possible to describe every conceivable combination of components or methods for purposes of describing the present specification, but one of ordinary skill in the art may recognize that many further combinations and permutations of the present specification are possible. Accordingly, the present specification is intended to embrace all such alterations, modifications and variations that fall within the spirit and scope of the appended claims. Furthermore, to the extent that the term “includes” is used in either the detailed description or the claims, such term is intended to be inclusive in a manner similar to the term



“comprising” as “comprising” is interpreted when employed as a transitional word in a claim.

What is claimed is:

1. A method, comprising:

identifying, by a system comprising a processor, a first mobile device in range of a femtocell access point device;

obtaining, by the system, location information from the femtocell access point device;

receiving, by the system, calculated time differences between the first mobile device and macrocell devices in range of the first mobile device;

determining, by the system, reference time differences for the macrocell devices as a function of the location information and the calculated time differences, wherein the reference time differences are timing offsets for respective macrocell devices relative to a baseline time; and

determining, by the system, a location of a second mobile device as a function of the reference time differences and a second set of calculated time differences between the second mobile device and the macrocell devices.

2. The method of claim 1, wherein the determining the reference time differences for the macrocell devices further comprises comparing the location information from the femtocell access point device and locations of the macrocell devices.

3. The method of claim 1, wherein the obtaining the location information from the femtocell access point device further comprises receiving the location information via an Iuh interface.

4. The method of claim 1, wherein the receiving the calculated time differences between the first mobile device and the macrocell devices further comprises receiving multiple calculated time differences over a period of time.

5. The method of claim 4, further comprising averaging, by the system, the calculated time differences, and recalculating the reference time differences.

6. The method of claim 4, wherein the receiving the calculated time differences further comprises receiving a primary scrambling code that identifies a macrocell device and an indication of a signal strength.

7. The method of claim 1, wherein the obtaining the location information from the femtocell access point device further comprises collecting a timestamp that corresponds to the location information.

8. A system, comprising:

a processor; and

a memory that stores executable instructions that, when executed by the processor, facilitate performance of operations, comprising:

determining that a first mobile device is within range of a femtocell access point device;

obtaining location information from the femtocell access point device and calculated time differences between the first mobile device and macrocell devices in range of the first mobile device; and

determining reference time differences for the macrocell devices using the calculated time differences and the location information, wherein the reference time differences are relative timing differences between the macrocell devices; and

determining a location of a second mobile device based on the reference time differences and a second set of calculated time differences between the second mobile device and the macrocell devices.

9. The system of claim 8, wherein the determining the reference time differences comprises determining the reference time differences in response to locations of the macrocell devices.

10. The system of claim 8, wherein the obtaining the location information from the femtocell access point device comprises obtaining the location information via a femtocell controller.

11. The system of claim 8, wherein the obtaining the calculated time differences from the first mobile device comprises obtaining the calculated time differences via network overhead resources.

12. The system of claim 8, wherein the obtaining the calculated time differences comprises obtaining multiple calculated time differences between the first mobile device and macrocell devices periodically over a period of time and the operations further comprise averaging the multiple calculated time differences to calculate new reference time differences.

13. The system of claim 8, wherein the operations further comprise obtaining primary scrambling codes that identify the macrocell devices that correspond to the calculated time differences.

14. The system of claim 8, wherein the operations further comprise initiating a notification that the first mobile device is not within range of the femtocell access point device.

15. The system of claim 14, wherein the operations further comprise ceasing to collect the calculated time differences from the first mobile device in response to the notification.

16. A non-transitory computer-readable storage medium having stored thereon computer-executable instructions that, in response to execution, cause a system comprising a processor to perform operations, comprising:

identifying a first mobile device in range of a femtocell access point device;

receiving location information from the femtocell access point device;

receiving a first set of calculated time differences between the first mobile device and macrocell devices in range of the first mobile device; and

determining reference time differences for the macrocell devices based on the location information and the calculated time differences, wherein the reference time differences are timing offsets for respective macrocell devices relative to a baseline time; and

determining a location of a second mobile device as a function of the reference time differences and a second set of calculated time differences between the second mobile device and the macrocell devices.

17. The non-transitory computer-readable storage medium of claim 16, wherein the determining the reference time differences for the macrocell devices further comprises comparing the location information from the femtocell access point device and locations of the macrocell devices.

18. The non-transitory computer-readable storage medium of claim 16, wherein the receiving the location information from the femtocell access point device further comprises receiving the location information via an Iuh interface.

19. The non-transitory computer-readable storage medium of claim 16, wherein the receiving the calculated time differences between the first mobile device and the macrocell devices further comprises receiving multiple calculated time differences over a period of time.

20. The non-transitory computer-readable storage medium of claim 16, wherein the operations further comprise:

averaging the calculated time differences, and recalculating the reference time differences.

\* \* \* \* \*