



US006432068B1

(12) **United States Patent**
Corl et al.

(10) **Patent No.:** **US 6,432,068 B1**
(45) **Date of Patent:** **Aug. 13, 2002**

(54) **HIGH OUTPUT THERAPEUTIC
ULTRASOUND TRANSDUCER**

5,334,183 A * 8/1994 Wuchinich 606/46
5,725,494 A * 3/1998 Brisken 604/22
6,016,023 A 1/2000 Nilsson et al.

(75) Inventors: **Paul D. Corl**, Palo Alto; **Joseph
Karratt**, Millbrae; **John McKenzie**,
San Carlos, all of CA (US)

FOREIGN PATENT DOCUMENTS

(73) Assignee: **Pharmasonics, Inc.**, Sunnyvale, CA
(US)

WO WO 00/18468 4/2000

(*) Notice: Subject to any disclaimer, the term of this
patent is extended or adjusted under 35
U.S.C. 154(b) by 0 days.

* cited by examiner

(21) Appl. No.: **09/531,027**

Primary Examiner—Marvin M. Lateef
Assistant Examiner—Jeoyuh Lin

(22) Filed: **Mar. 20, 2000**

(74) *Attorney, Agent, or Firm*—Townsend and Townsend
and Crew LLP

(51) **Int. Cl.**⁷ **A61H 1/00**

(57) **ABSTRACT**

(52) **U.S. Cl.** **601/2; 604/22**

(58) **Field of Search** 600/437, 439,
600/481; 604/20, 21, 22; 601/2; 606/127,
128

A therapeutic ultrasound energy delivery system includes a
probe having a vibrational transducer. A restraint is disposed
about the transducer in order to exert a compressive pre-
stress on the transducer. The restraint inhibits tensile failure
of the vibrational transducer at high acoustic output.

(56) **References Cited**

U.S. PATENT DOCUMENTS

5,069,664 A * 12/1991 Guess et al. 604/22

45 Claims, 15 Drawing Sheets

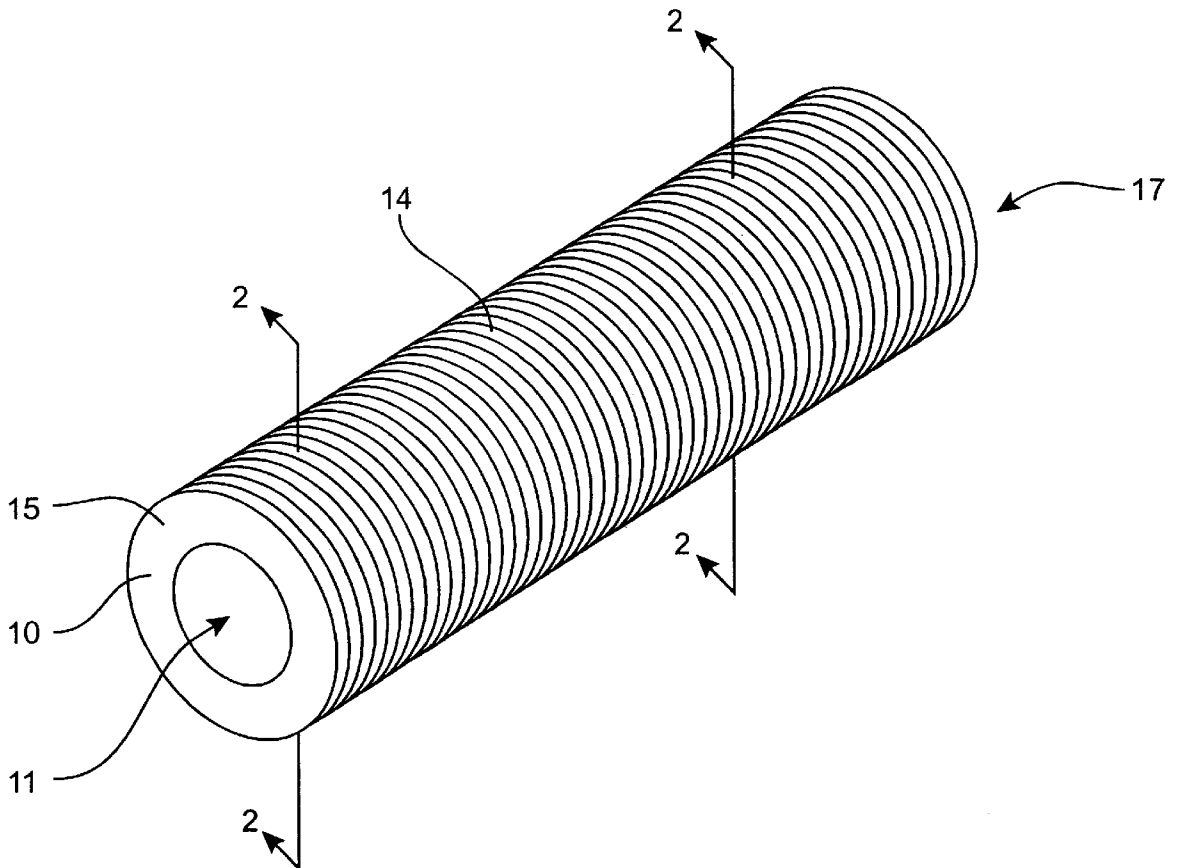

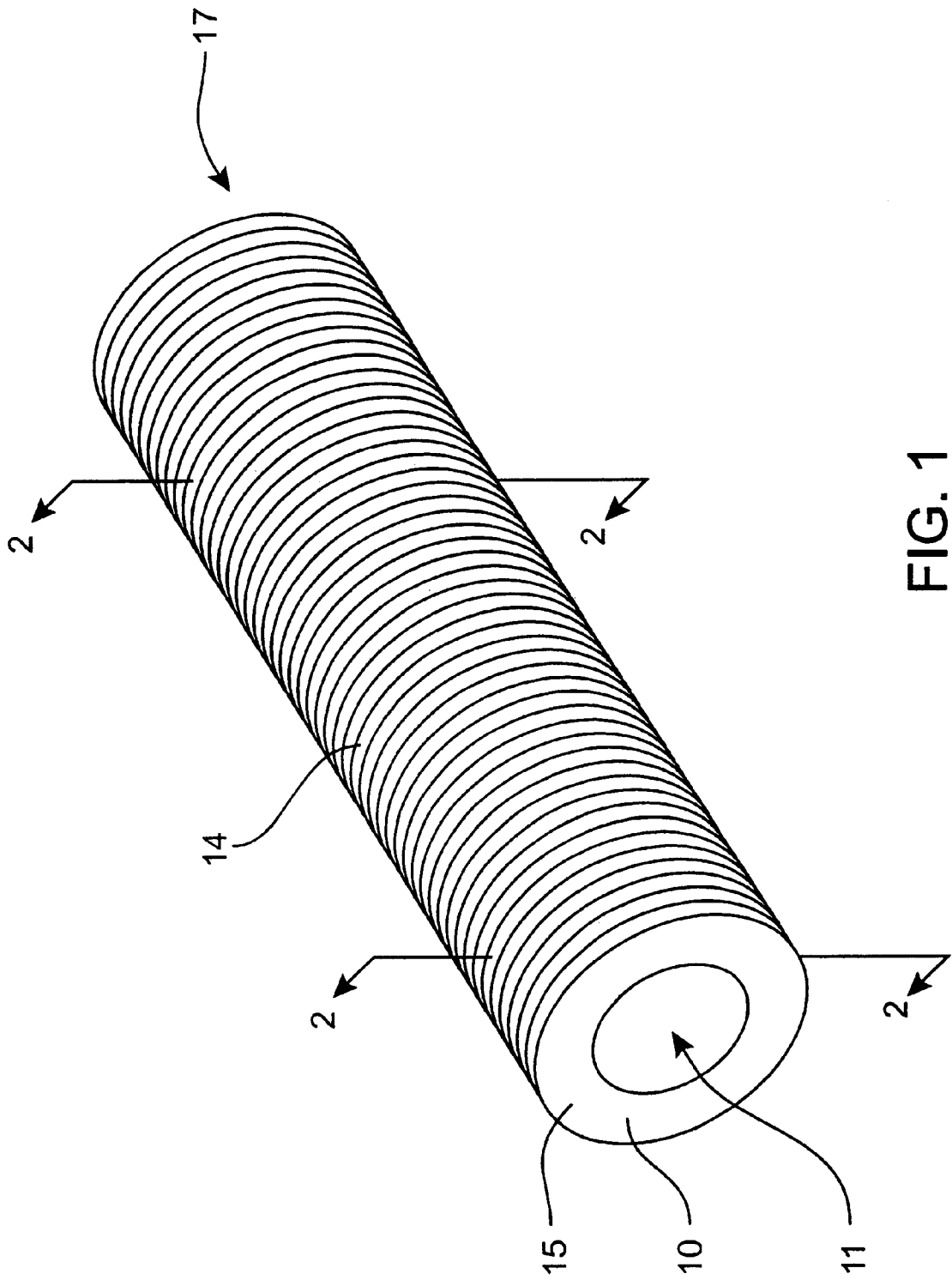

FIG. 1

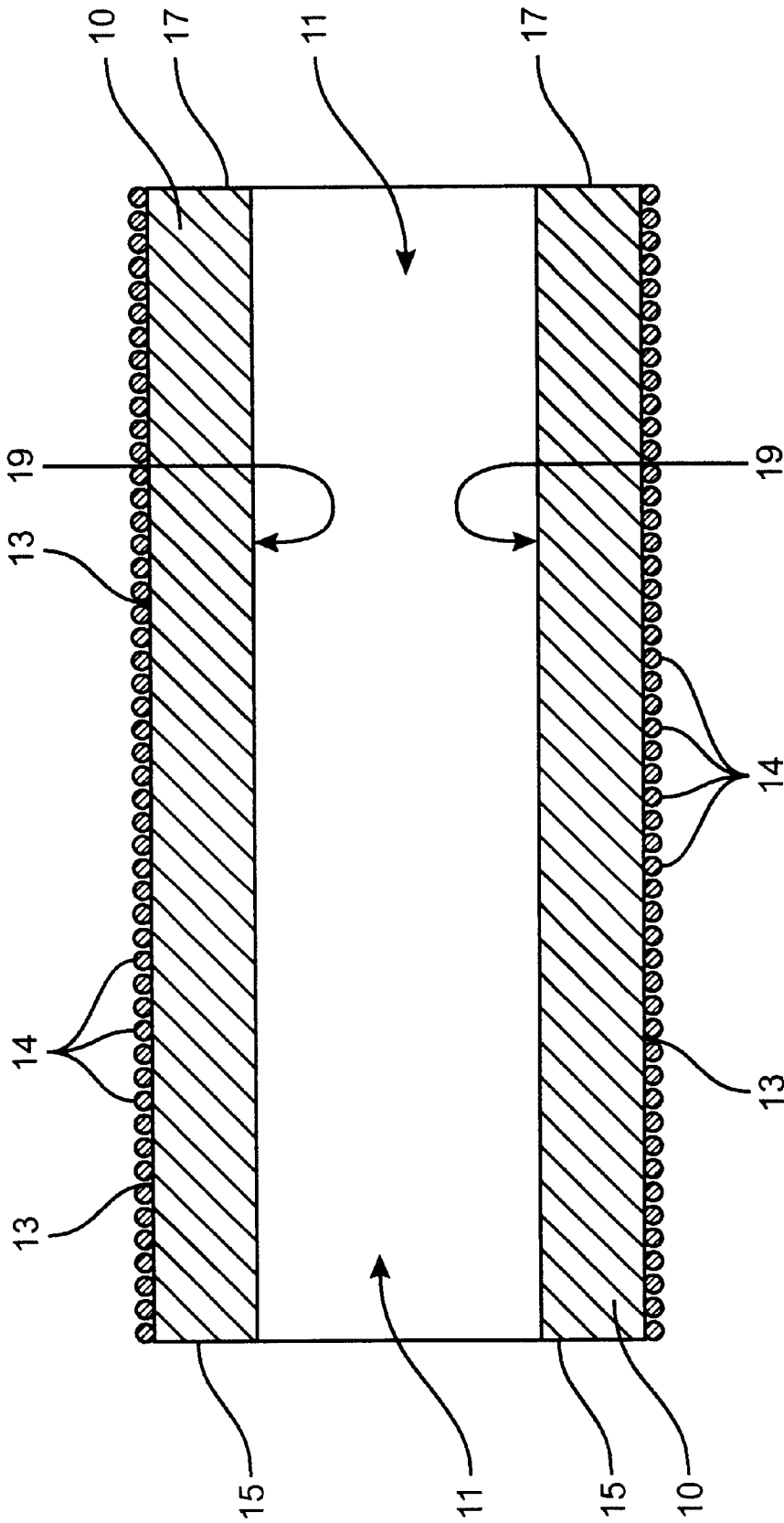

FIG. 2

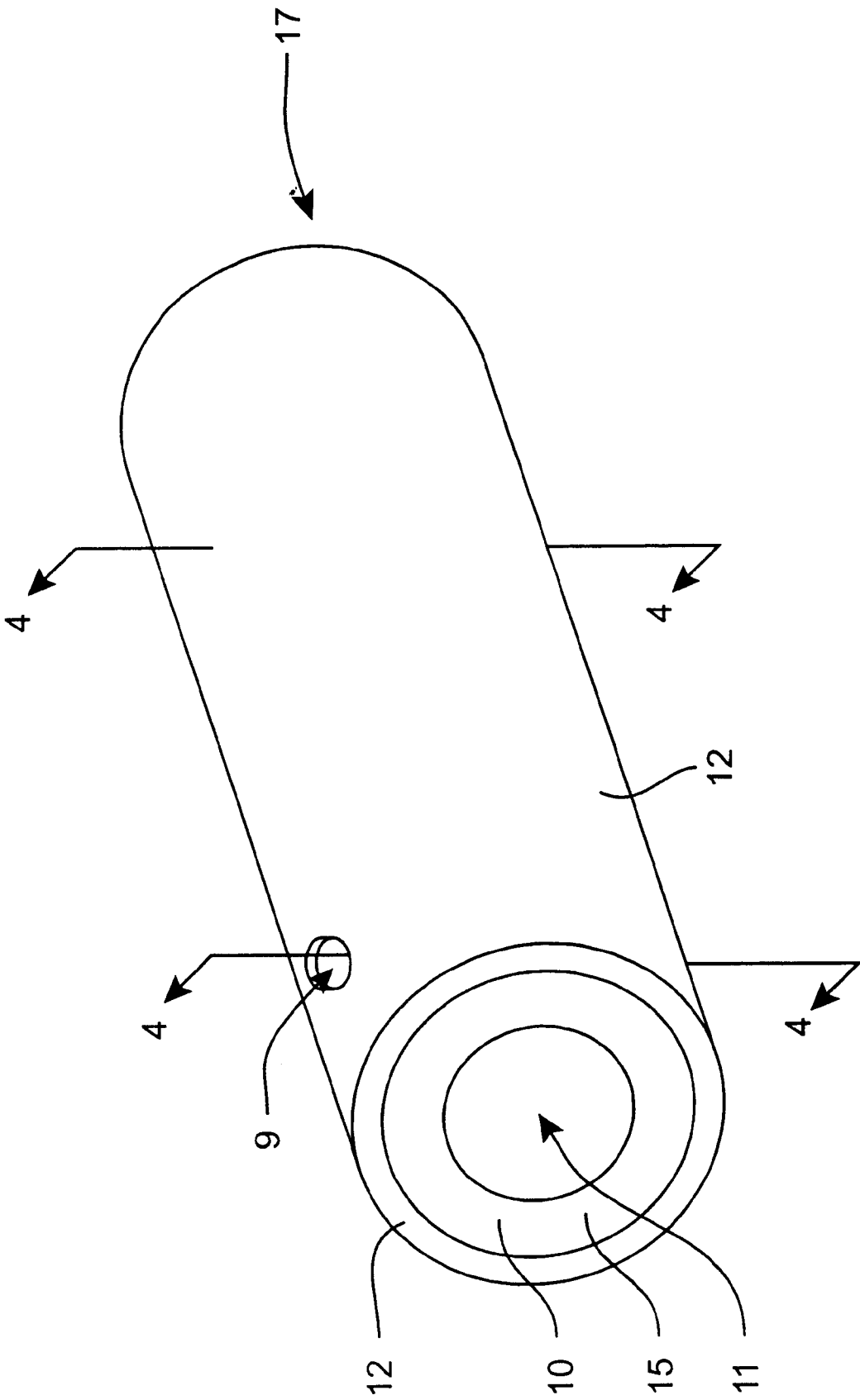

FIG. 3

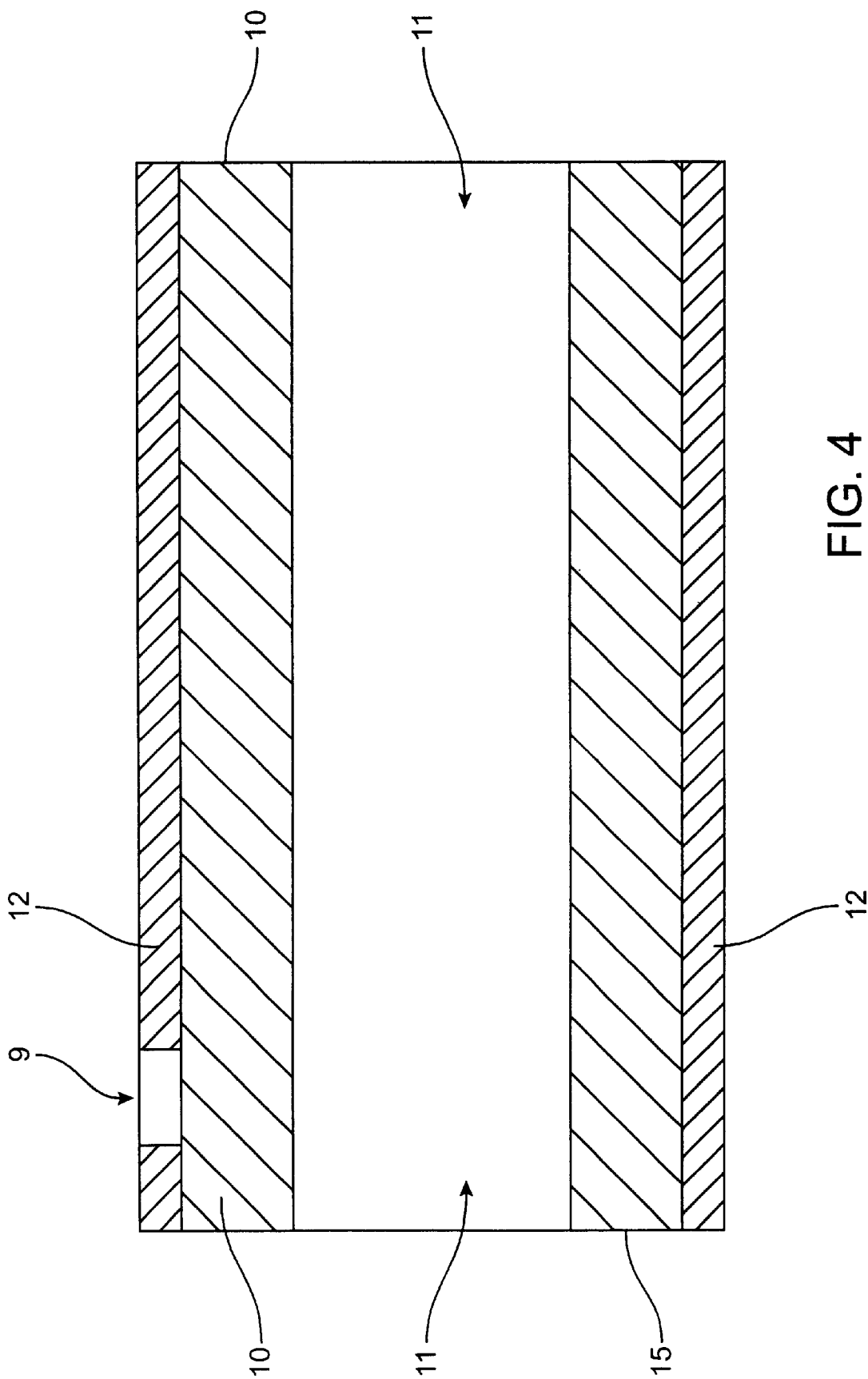

FIG. 4

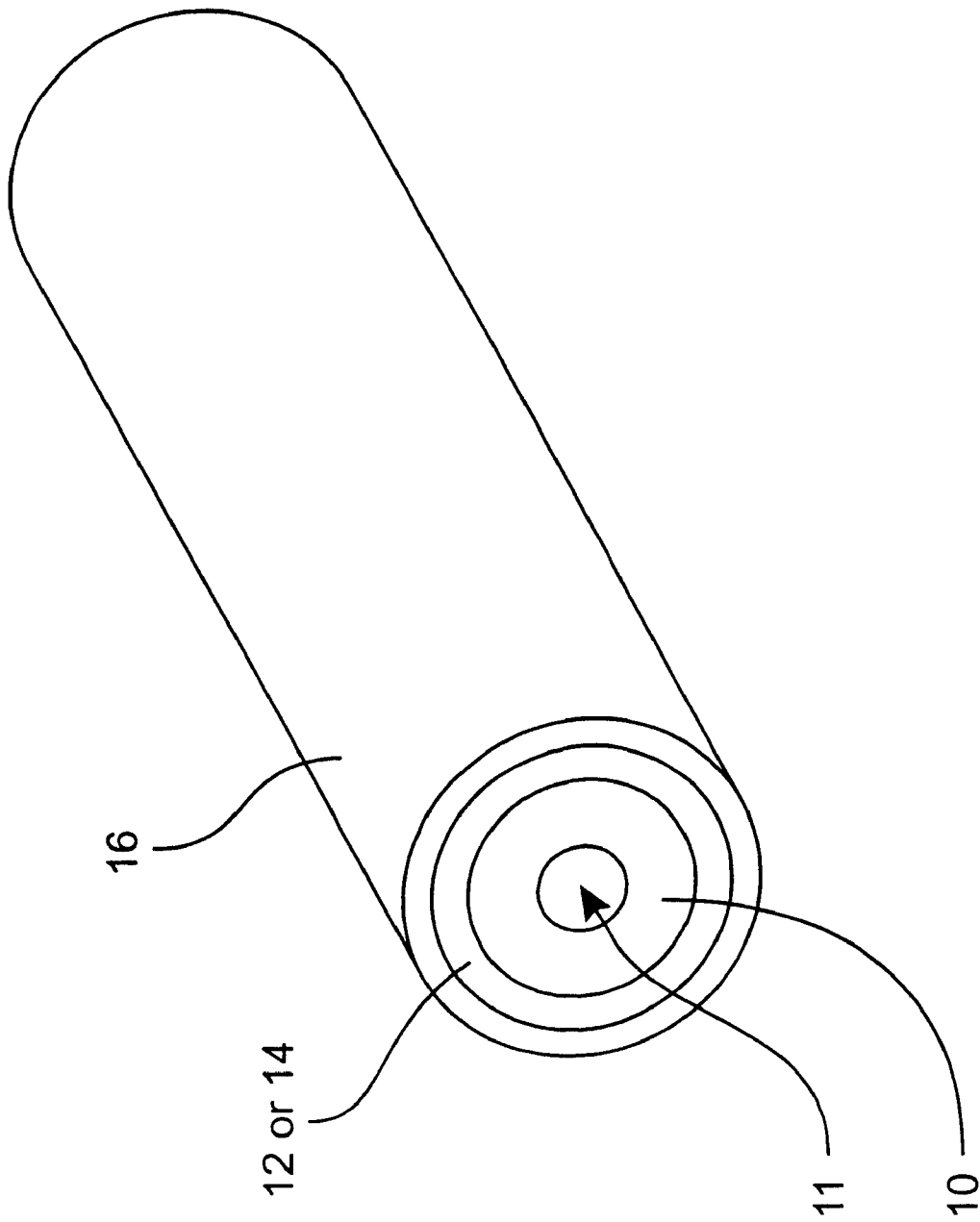

FIG. 5

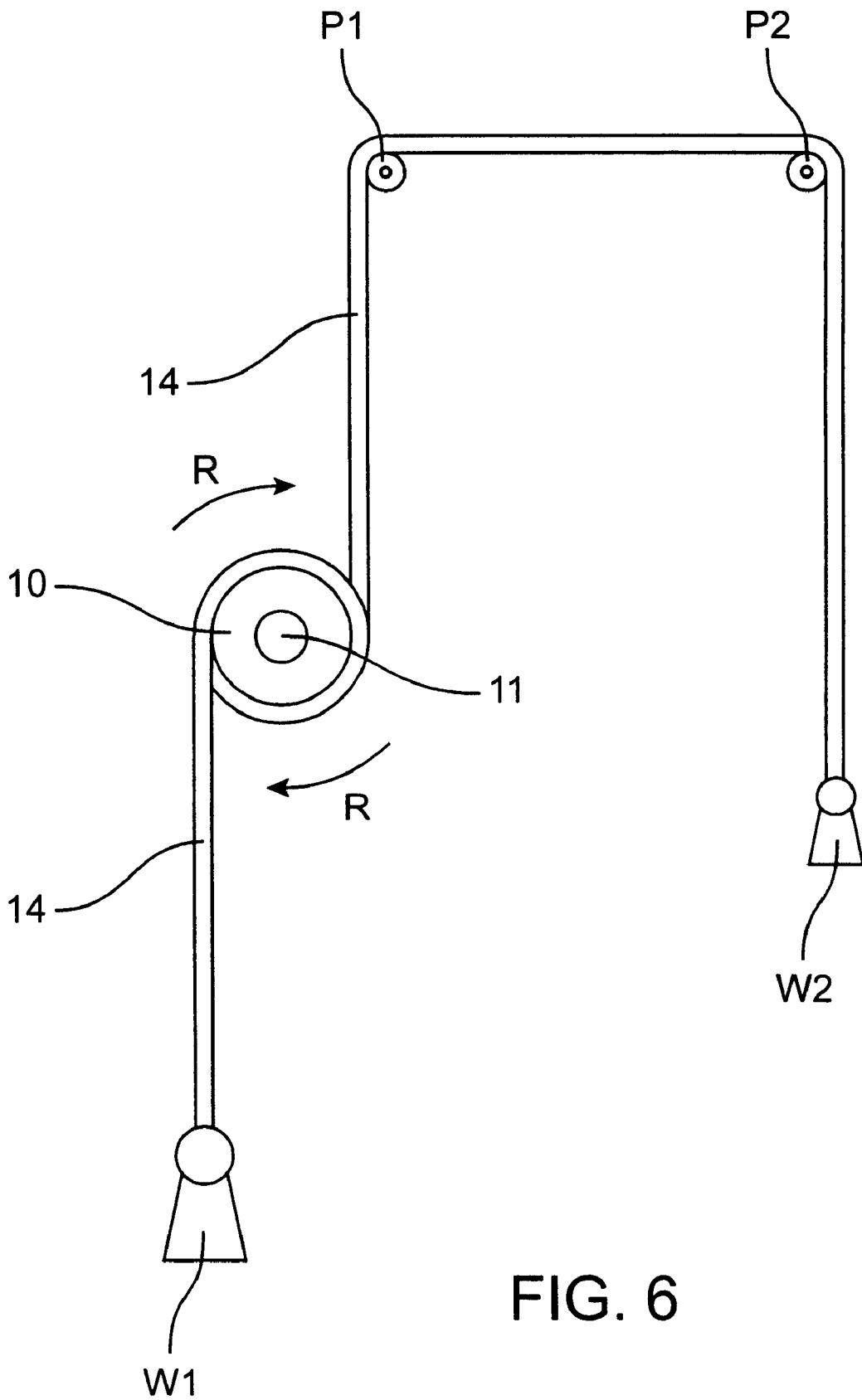

FIG. 6

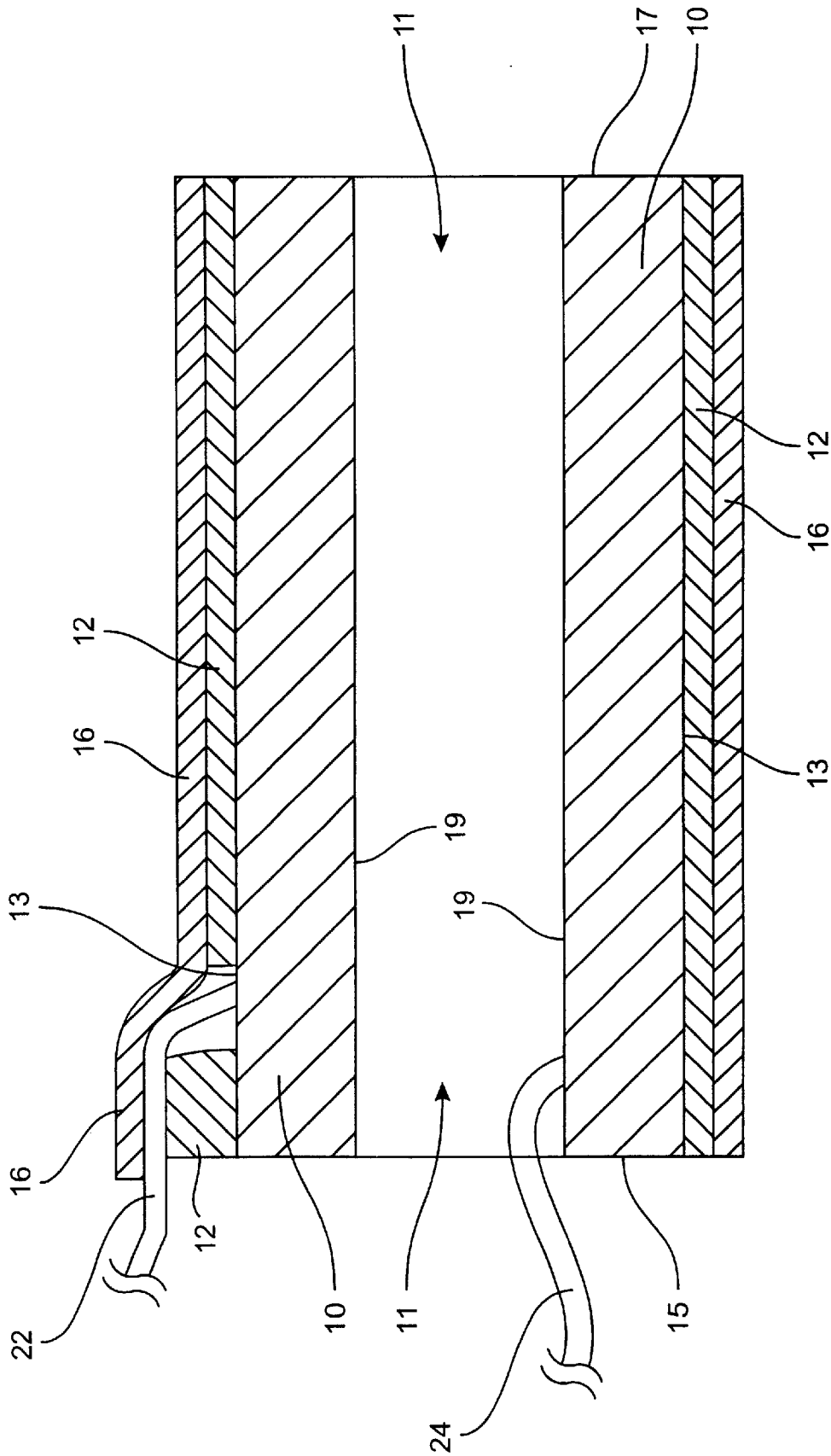

FIG. 7A

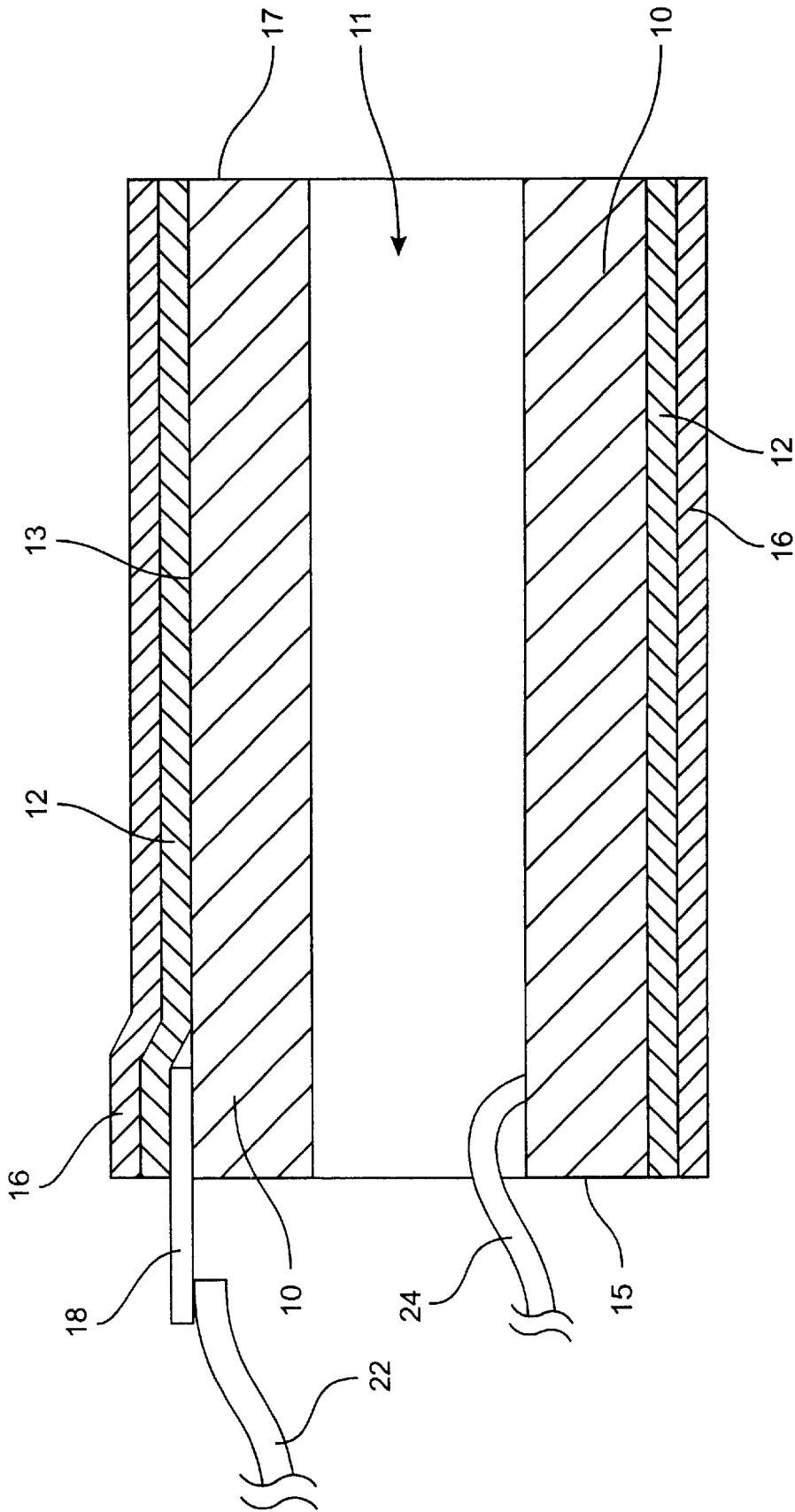

FIG. 7B

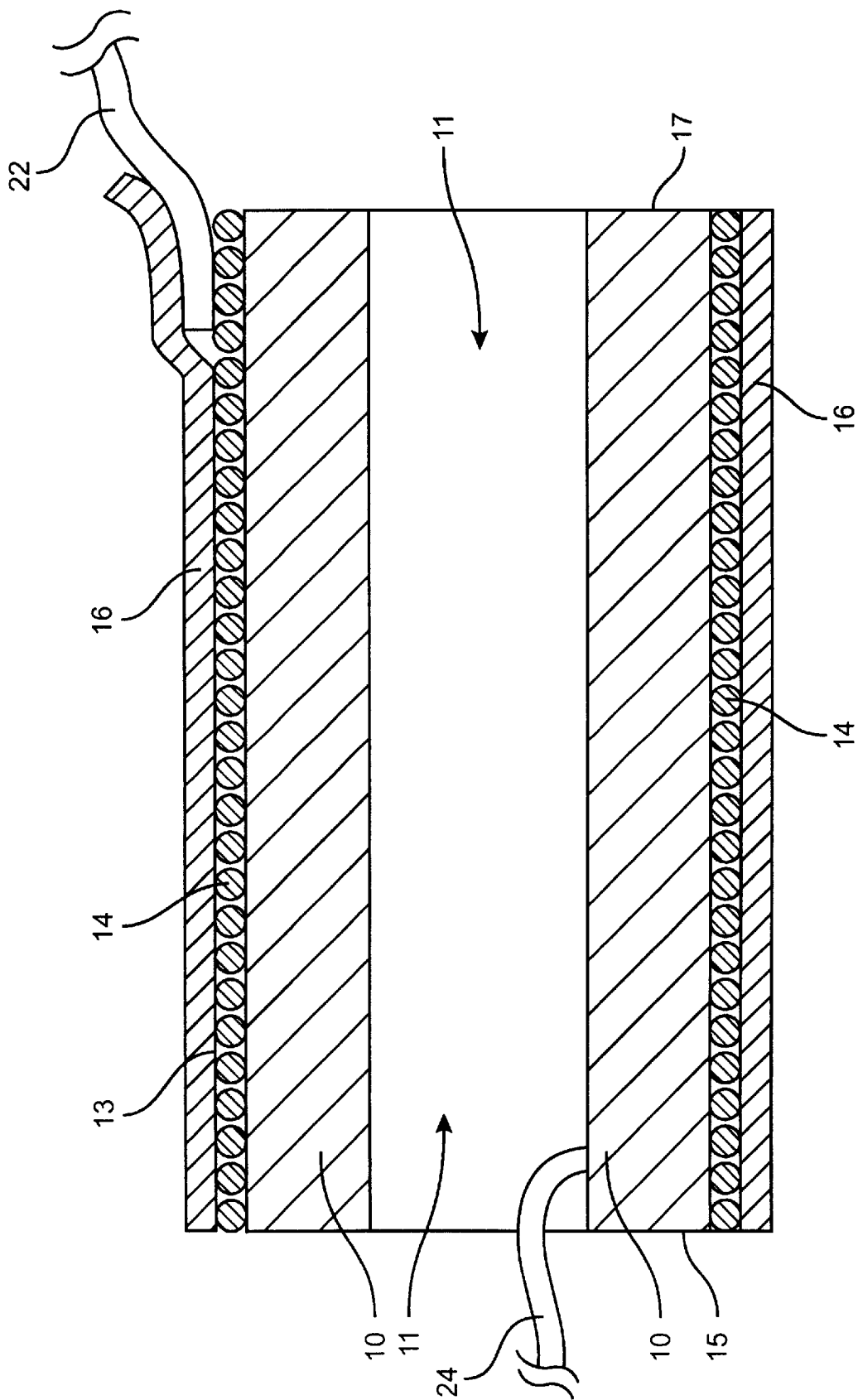

FIG. 7C

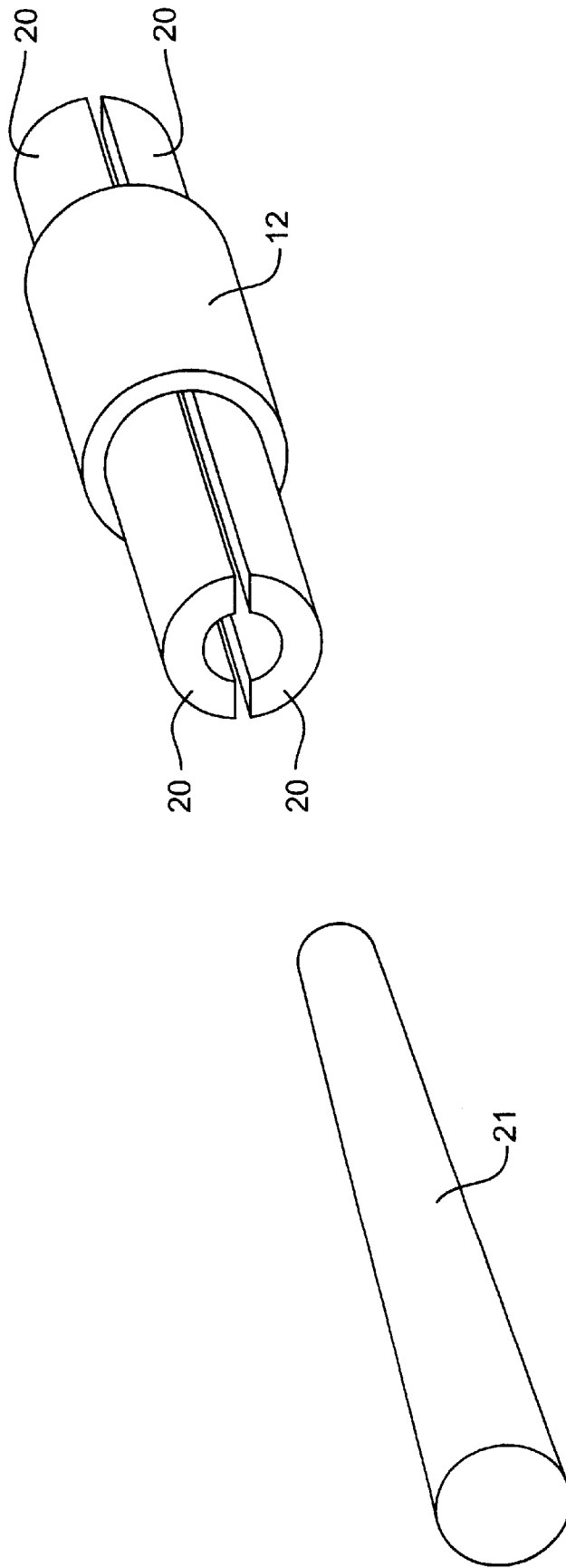

FIG. 8

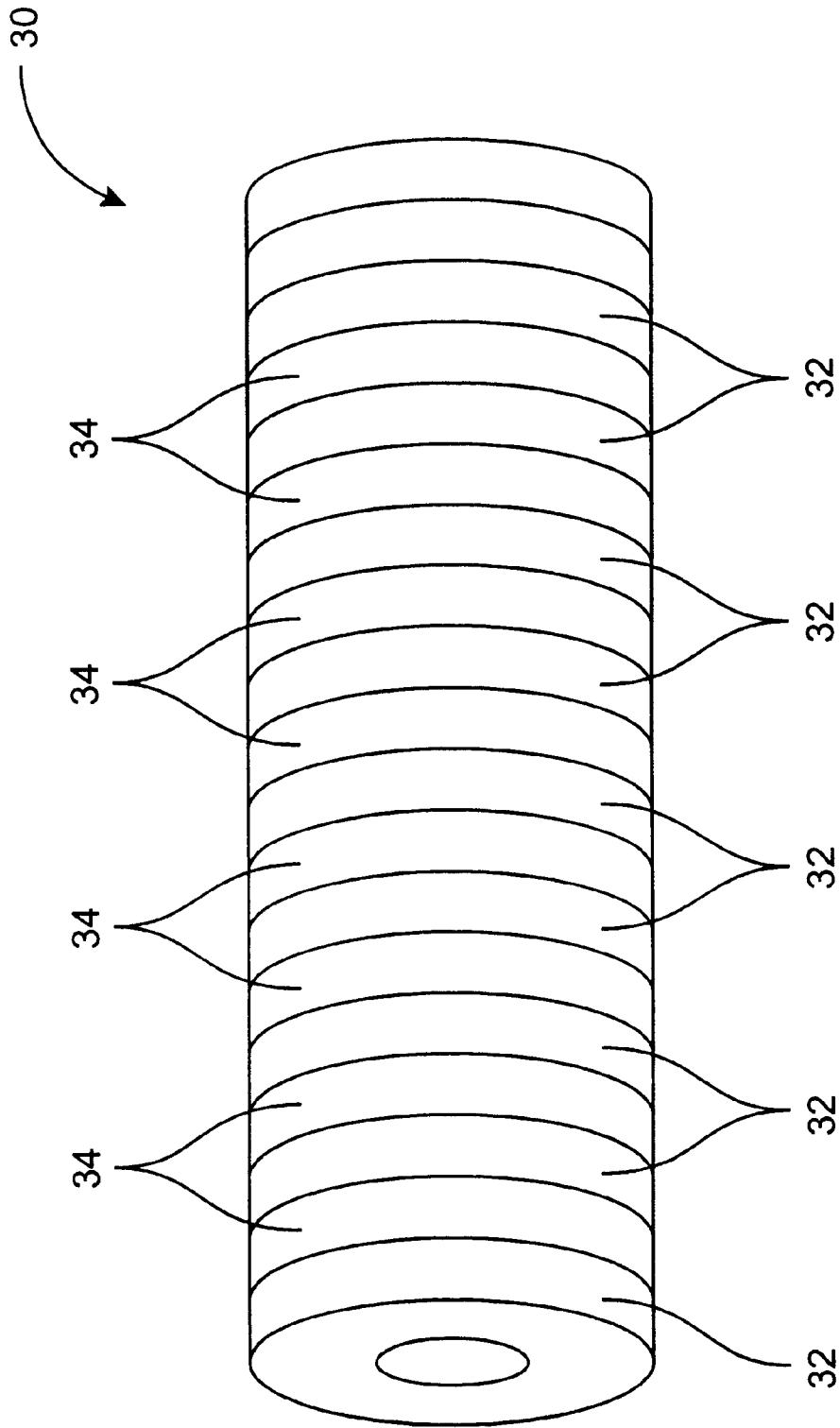

FIG. 9

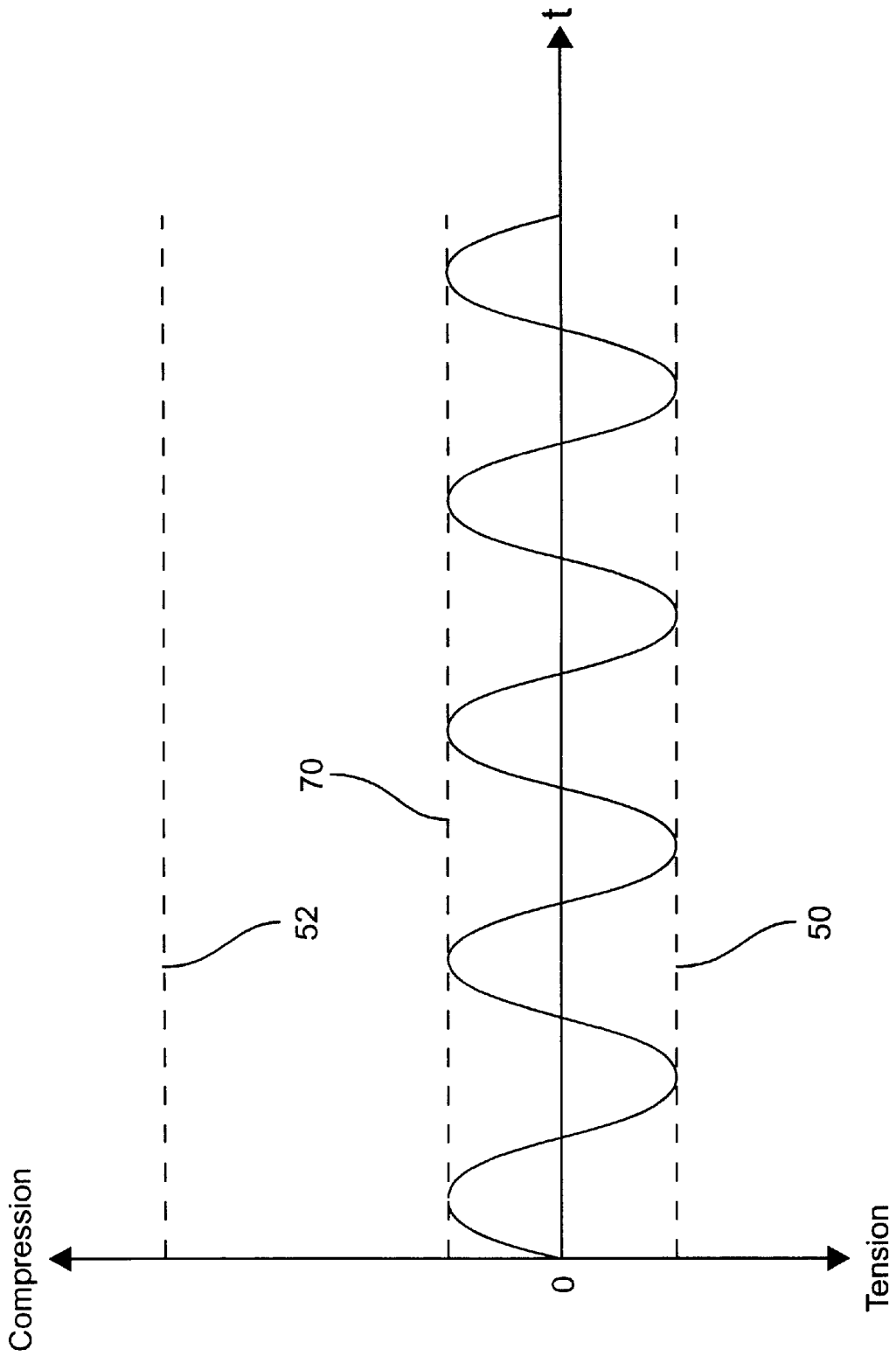

FIG. 10

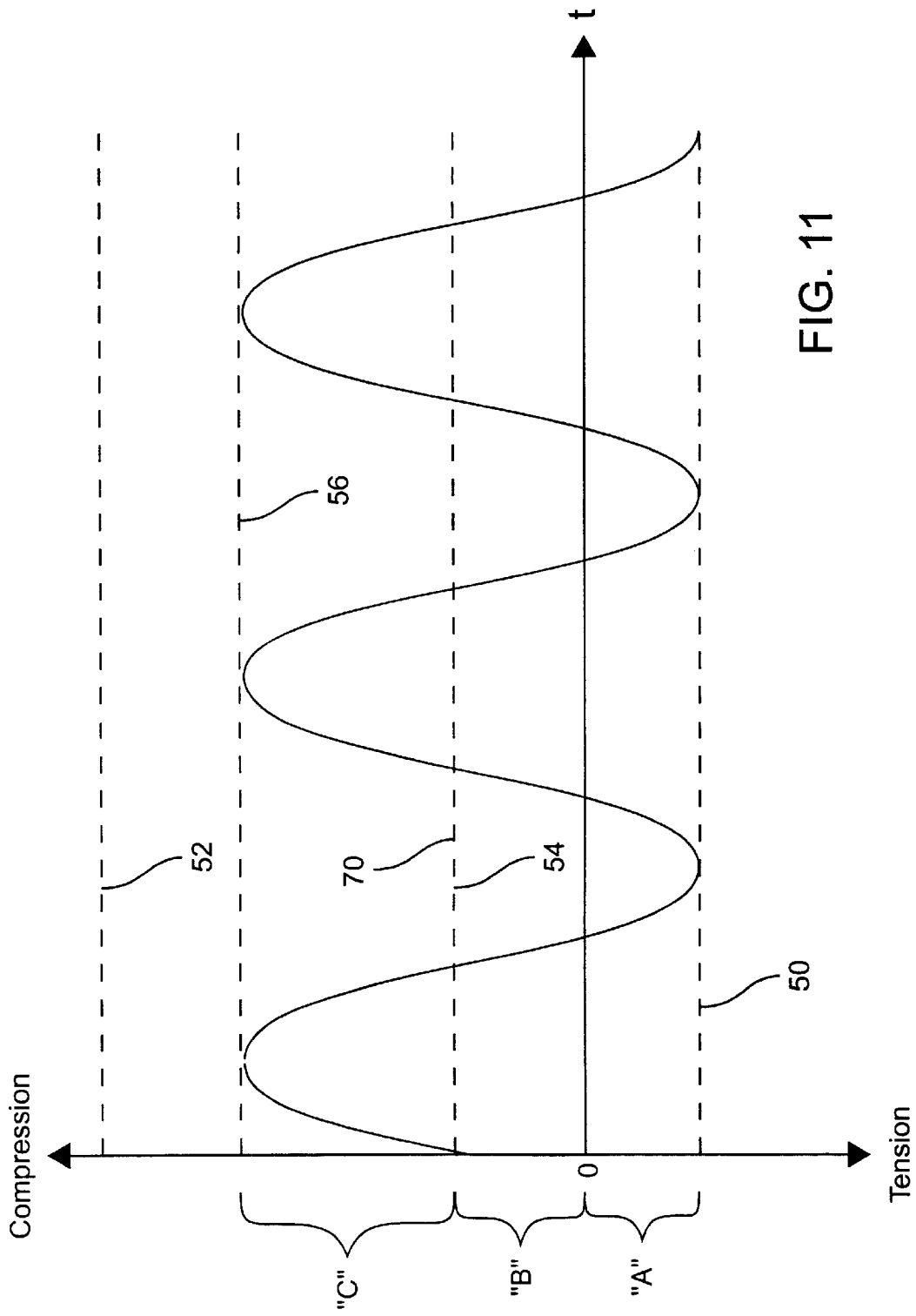

FIG. 11

NB: Distance "A" = Distance "B"
Distance "C" = Distance "A"+"B"

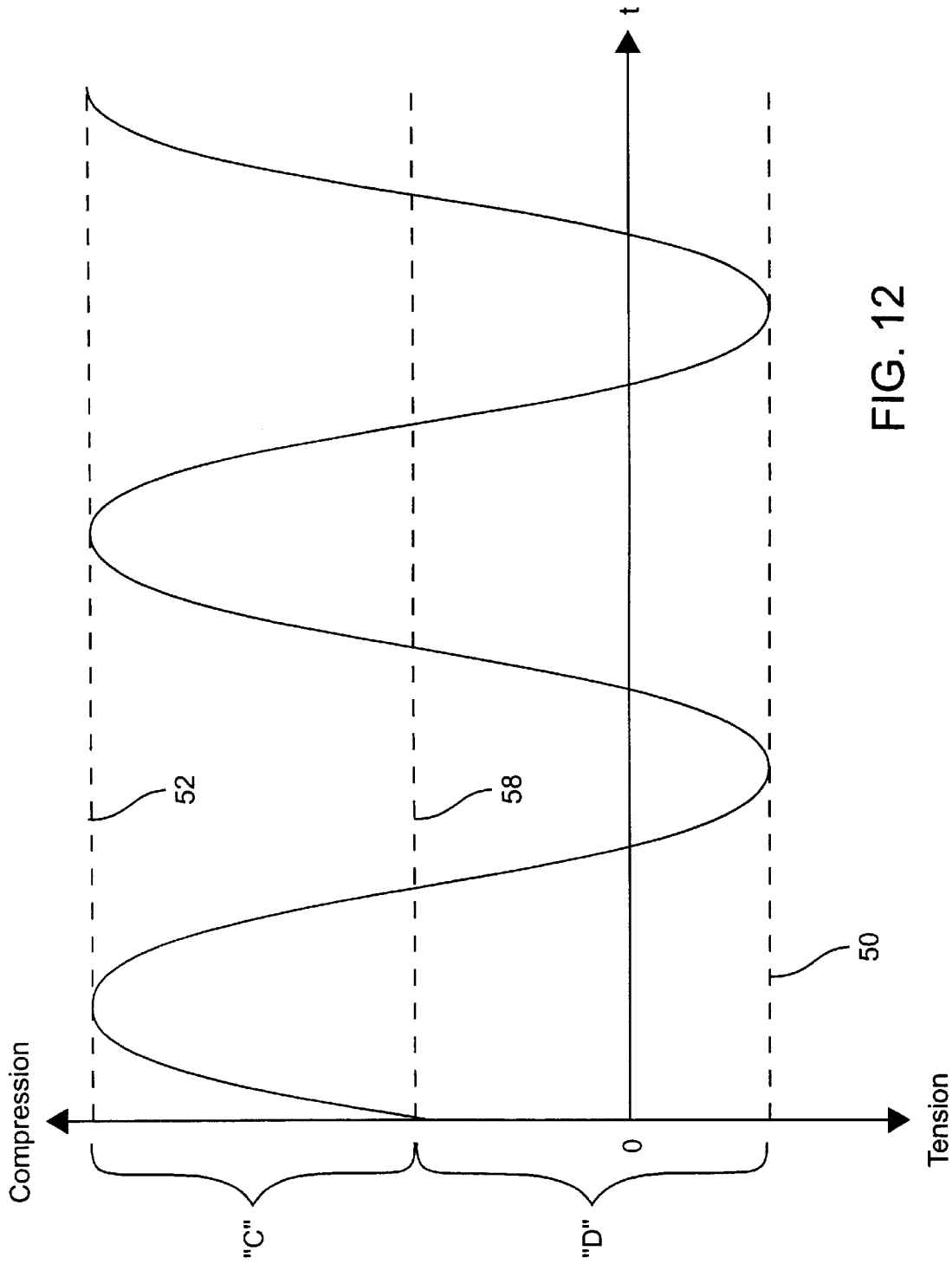

FIG. 12

NB: Distance "C" = Distance "D"

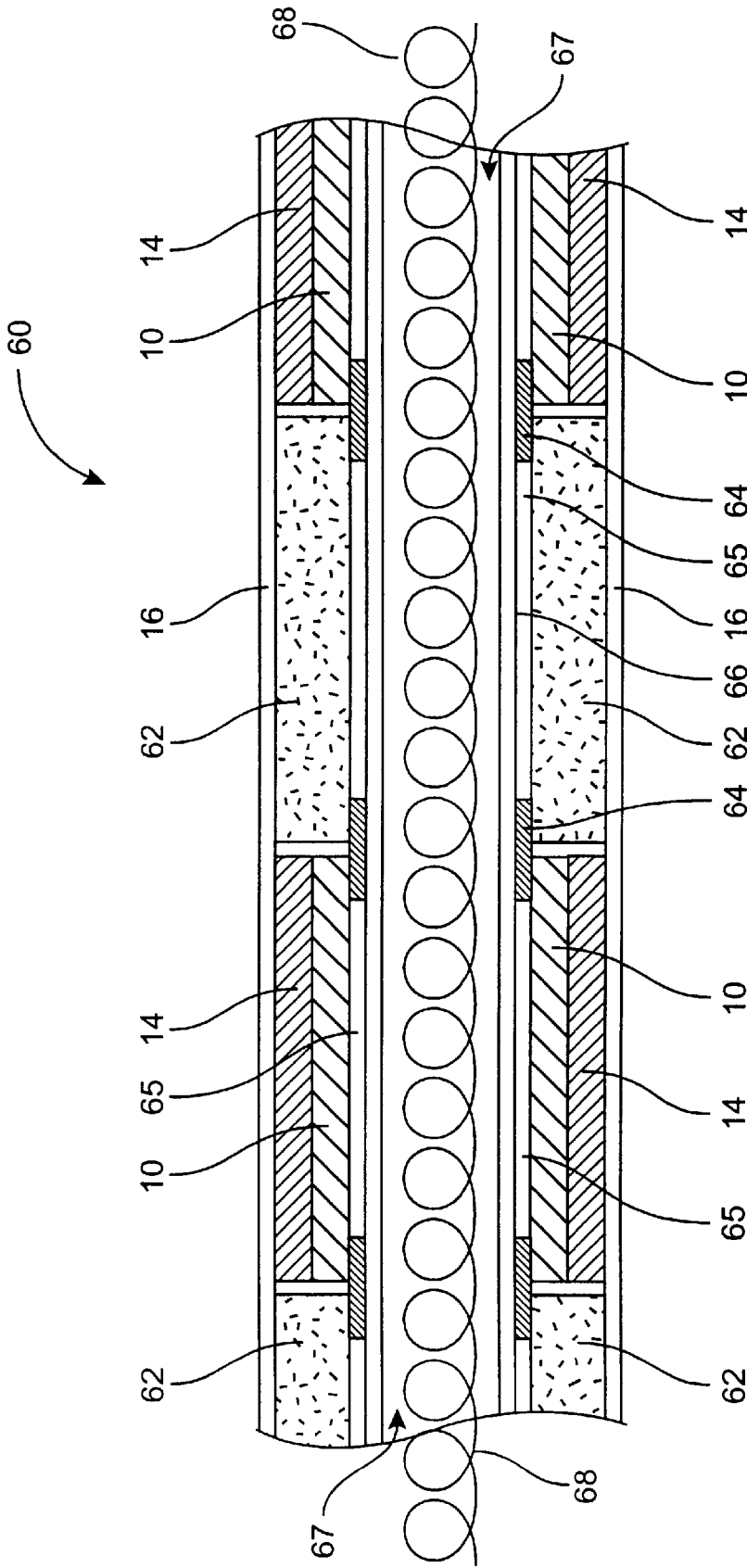

FIG. 13

HIGH OUTPUT THERAPEUTIC ULTRASOUND TRANSDUCER

TECHNICAL FIELD

The present invention is related to medical devices and systems, particularly therapeutic ultrasound systems.

BACKGROUND OF THE INVENTION

Percutaneously introduced catheters having ultrasound transducers thereon can be used to deliver localized doses of therapeutic ultrasound energy to various sites within a body. Such systems are ideally suited for treating or preventing pathological conditions such as arterial restenosis due to intimal hyperplasia.

To achieve a high level of therapeutic effectiveness, a high amplitude of ultrasound vibration is required. Unfortunately, the acoustic output from a conventional transducer design is typically limited by the inherent properties of the piezoelectric material which forms the transducer. Specifically, when operating typical piezoelectric ceramic transducers at high vibrational amplitudes, the ceramic tends to fracture. This transducer failure is caused by the high tensile stresses within the ceramic material during transducer operation, and the problem is exacerbated by the fact that although piezoelectric ceramic materials tend to have high compressive strengths, they have relatively low tensile strengths.

SUMMARY OF THE INVENTION

The present invention provides ultrasound and other vibrational transducer systems comprising a vibrational transducer, typically an ultrasound transducer, which can be operated at very high vibrational amplitudes without failure. As such, the present invention provides systems to prevent the ultrasound transducer, which preferably comprises a ceramic piezoelectric material, from breaking apart at high amplitude operation.

The present ultrasound transducer system is ideally suited for use in a catheter based therapeutic ultrasound energy delivery system.

In a preferred aspect, the present invention comprises a piezoelectric ceramic ultrasound transducer having a restraint received therearound. The restraint is dimensioned or otherwise formed to have a structure which exerts a compressive pre-stress on the piezoelectric ceramic transducer element where the stress can be maintained during the operation of the transducer. Advantageously, the compressive pre-stress provided by the restraint operates to prevent tensile failure of the ceramic transducer at high acoustic output.

In a preferred aspect, the strength of the compressive pre-stress provided by the restraint on the transducer is approximately equal to the tensile strength of the transducer element. As will be explained, when this occurs, the restrained transducer can provide approximately twice the acoustic output of a comparable un-restrained device before tensile failure occurs.

In one exemplary aspect, the strength of the compressive pre-stress provided by the restraint is approximately half-way between the tensile strength and the compressive strength of the ceramic transducer material. As will be explained, when this occurs, the restrained transducer can be operated at a significantly increased output amplitude without failure.

In various preferred aspects, the compressive pre-stress provided by the restraint is just high enough to permit

operation of the device without tensile failure at an output amplitude determined to be safe and effective for treating or preventing a pathological condition such as arterial restenosis due to intimal hyperplasia. In these preferred aspects, the required thickness and stiffness (as described below) of the restraint may be preferably kept to the minimum necessary to meet the acoustic output requirements, thereby minimizing the size of the device, and minimizing the requirements of the electrical drive circuitry, while maximizing the efficiency of the device in converting electric power into acoustic power.

In preferred aspects, the restraint may comprise a tensioned wire or filament(s) which is/are wrapped around the transducer. In other aspects, the restraint may comprise a jacket having an inner diameter which is initially fabricated to be slightly smaller than the outer diameter of the transducer. The jacket is then stretched to expand to a larger diameter such that it can just be received over the transducer. The transducer is then inserted within the expanded jacket, and the jacket is then allowed to contract such that it exerts a compressive pre-stress on the transducer. Systems for fabricating the jacket from a shape memory metal such as a nickel Titanium alloy (e.g.: Nitinol™) are also set forth.

The transducer is preferably cylindrically shaped, and may have an optional central longitudinal bore passing therethrough, with the bore defining an inner surface of the transducer. In various aspects, the inner and outer surfaces of the transducer are covered in whole or in part by an electrode. In alternative aspects, the opposite longitudinal ends of the transducer are covered in whole or in part by an electrode. In alternate embodiments of the invention, the transducer is formed from a series of alternating annular shaped polymer and piezoelectric ceramic rings, commonly referred to as a piezoelectric stack.

In a preferred aspect of the invention, the vibrational mode of the transducer is a relatively low frequency "breathing mode", wherein the circumference of the cylinder oscillates around a nominal value, and the stress within the ceramic is predominantly in the tangential direction. In this case, tensile stress from the vibration of the transducer which may otherwise lead to failure can be balanced by compressive pre-stress in the tangential direction applied by a wrapped jacket type restraint.

In an exemplary aspect, the transducer may be made of a PZT-8, (or PZT-4) ceramic material, but other piezoelectric ceramics, electro-strictive ceramic materials, or non-ceramic materials such as piezoelectric crystals may be used as well.

In the aspect of the invention in which a wrapped restraint is used, the tensioned member wrapped around the transducer may be a metal wire, metal or polymeric braid, mono-filament polymer, glass fiber, or a bundle of polymer, glass or carbon fibers. Wires may have circular cross sections or be formed as a ribbon or square wire. In various aspects, the wire is placed under tension when initially wrapped around the ultrasound transducer so as to maintain the compressive pre-stress on the transducer. Alternatively, the tension may be introduced after the wrapping is applied using thermal, chemical, mechanical or other type of process.

Suitable materials which may be used for either of the wrapped or jacket-type restraints described herein include, but are not limited to, high tensile strength elastic material selected from the group consisting of steel, titanium alloys, beryllium copper alloys, nickel, titanium and other shape memory alloys (e.g.: Nitinol™), and epoxy impregnated kevlar, glass, polyester or carbon fiber. In one exemplary

embodiment of the invention, the restraint comprises a 0.001"×0.003" Beryllium Copper alloy ribbon wire having a tensile strength of 150,000 psi or greater, wrapped around the transducer under 0.25 lbs of tension.

In aspects of the invention where the restraint comprises a wire or ribbon wire, the restraint may comprise multiple layers of wire or ribbon wrappings using thinner ribbon or smaller wire than would be used for a single layer of wrapped restraint. An advantage of using such smaller diameter wire or thinner ribbon wire would be that reduced bending stress would be experienced during the wrapping process, thereby permitting the wire or ribbon to be tensioned to a higher average stress without breaking. This in turn would allow a higher compressive pre-stress to be applied to the ceramic transducer element using a thinner and less stiff restraint than would instead be required for a single layer wrap of the same material.

In those aspects of the invention where the restraint comprises a wire, ribbon wire, or other fiber under tension, the wire restraint may be fixed in place on the surface of the transducer by gluing, soldering or welding, with the compressive pre-stress being maintained during the operation of the transducer. Such fixation could be continuous or only at spaced apart points or regions along the contact length between the restraint and the transducer.

The use of a beryllium copper alloy wire as the restraint has numerous advantages including its high tensile strength, (typically 150 kpsi or greater), corrosion resistance and conductive properties. A further advantage is that a beryllium copper alloy wire is easily solderable. As such, it may be soldered both to an outer surface of the transducer, and between adjacent wraps around the transducer without the need for a special solder tab. In addition, a beryllium copper alloy wire can easily be soldered at temperatures below the Curie temperature of the ceramic transducer material, (which is about 300° C. for PZT-8 ceramic). Typically as well, a beryllium copper alloy wire has a tensile strength / modulus of elasticity on the order of 190 kpsi/19 Mpsi= $\frac{1}{100}$ advantageous ration is similar to that of stainless steel which typically has a tensile strength /modulus of elasticity on the order of 300 kpsi/30 Mpsi= $\frac{1}{100}$.

In the aspects of the invention where the restraint comprises a jacket, such jacket may be made from a very high strain limit material having good elastic properties and high tensile strength. Such a jacket could first be formed and then expanded to be slipped over the transducer and then allowed to recover, thereby radially compressing the transducer. If instead fabricated from Nitinol™, the jacket can be formed and then expanded to be slipped over the transducer. If maintained at a sufficiently low temperature, the jacket will maintain its expanded size as it is placed over the transducer. When the temperature is allowed to rise above a critical value the jacket material will contract, thereby applying compressive pre-stress to the transducer.

In preferred aspects, a composite polymer is applied over the outside of the restraint. The composite polymer is adapted to dampen longitudinal axis vibrations, to provide an electrical insulating layer and to provide a convenient surface to which an outer jacket of the catheter may be attached. Suitable materials for such a composite polymer include, but are not limited to, materials selected from the group consisting of high strength adhesives such as epoxy or cyano-acrylate, and polymers such as heat-shrinkable PVDF, polyester, nylon, Pebax, PVDF or polyethylene.

The present invention also provides methods of generating and delivering high levels of therapeutic ultrasound

energy to a patient. In particular, the present invention provides methods of delivering a high output from a therapeutic ultrasound energy delivery system by exerting a compressive pre-stress on a piezoelectric ceramic ultrasound transducer with a restraint wrapped or formed to be disposed around the transducer; and by maintaining the compressive pre-stress on the transducer during the operation of the transducer. In various aspects, the exertion of a compressive pre-stress on the ultrasound transducer is achieved by wrapping a tensioned wire or fiber(s) around the transducer. In other aspects, exerting a compressive pre-stress on the ultrasound transducer is achieved by expanding a jacket to a diameter sufficient to be received over the transducer, inserting the transducer into the jacket and allowing the jacket to contract against the outer surface of the transducer, or by fabricating the restraint from a shape memory material such as Nitinol™ expanded to fit over the transducer and then shrunk with heat to apply a compressive pre-stress to the transducer.

In preferred aspects, the ultrasound transducer is cylindrical in shape and may further comprise a longitudinally extending bore therethrough. When air is disposed within this bore, the ultrasound energy emitted by the transducer will be directed predominately radially outwards, since very little ultrasound energy passes from the dense ceramic transducer into the low density air. Thus, the efficiency of the transducer can be enhanced, providing an ideal transducer system for mounting on a catheter.

BRIEF DESCRIPTION OF THE DRAWINGS

FIG. 1 is a perspective view of a cylindrical shaped ultrasound transducer having a wire restraint wrapped there-around.

FIG. 2 is a sectional view taken along lines 2—2 in FIG. 1.

FIG. 3 is a perspective view of a cylindrical shaped ultrasound transducer having a restraining jacket received thereover.

FIG. 4 is a sectional view taken along lines 4—4 in FIG. 3.

FIG. 5 is a perspective view of a transducer and restraint received within an outer coating.

FIG. 6 is an illustration of a system for wrapping a tensioned wire around an ultrasound transducer.

FIG. 7A is a sectional view corresponding to FIG. 5, showing electrodes attached to inner and outer surfaces of the transducer, with the restraining jacket as shown in FIGS. 3 and 4.

FIG. 7B corresponds to FIG. 7A, but instead shows an electrode connected to the outer surface of the transducer by way of a solder tab.

FIG. 7C corresponds to FIG. 5, but instead shows an electrode soldered directly to the restraining wire, as illustrated in FIGS. 1 and 2.

FIG. 8 illustrates a tool for expanding a jacket such that it can be received over the transducer.

FIG. 9 shows an alternate ultrasound transducer comprising alternating annular piezoelectric and polymer sections.

FIG. 10 shows a stress vs. time plot for an unrestrained transducer.

FIG. 11 shows a stress vs. time plot for a restrained transducer, operating at less than optimal output.

FIG. 12 shows a stress vs. time plot for a restrained transducer, operating at optimal output.

FIG. 13 shows a plurality of the present transducers mounted to a catheter system for delivering therapeutic ultrasound to a patient.

DESCRIPTION OF THE SPECIFIC EMBODIMENTS

A problem common to therapeutic ultrasound transducers is that when operating an ultrasound transducer such as a piezoelectric ceramic transducer at a very high output, the transducer will tend to fracture. Accordingly, the therapeutic effectiveness of catheter based ultrasound delivery systems have been somewhat limited since the level of vibrational amplitude of therapeutic ultrasound energy which their transducers are able to emit is limited, especially over prolonged periods of operation.

Referring to FIGS. 1 and 2, the present invention provides a system for preventing fracture of a ultrasound transducer, (such as a ceramic ultrasound transducer), when the transducer is operated at a high output. In a first aspect, the present invention provides a system for preventing tensile failure in a transducer 10, by way of a wire 14 which is wrapped tightly around transducer 10. As can be seen, transducer 10 is cylindrical shaped, having an optional longitudinally extending central bore 11 extending there-through.

In various preferred embodiments, transducer 10 has a preferred outer diameter of 0.25 to 0.02 inches, a more preferred outer diameter of 0.175 to 0.03 inches, and a most preferred outer diameter of 0.100 to 0.03 inches.

In various preferred embodiments, transducer 10 has a preferred inner diameter of 0.2 to 0.01 inches, a more preferred inner diameter of 0.125 to 0.015 inches, and a most preferred inner diameter of 0.05 to 0.015 inches.

In various preferred embodiments, transducer 10 has a preferred length of 1.0 to 0.01 inches, a more preferred length of 0.750 to 0.010 inches, and a most preferred length of 0.5 to 0.01 inches.

It is to be understood, however, that the preferred dimensions set forth herein are merely exemplary and that the present invention is not so limited to the dimensions set forth herein.

In preferred aspects, the present system provides a "high output" of therapeutic ultrasound energy, being defined herein as being greater than that used for diagnostic imaging. In a most preferred aspect of the present invention, such "high output" is equal to or greater than 1.9 MI (mechanical index). In preferred aspects, the "high output" is achieved with an MI less than that at which cavitation damage occurs.

In preferred aspects, the present "high output" therapeutic ultrasound system is operated at an exemplary frequency range of equal to, or greater than, 500 KHz, and less than, or equal to, 3 MHz.

Preferably, wire 14 is pretensioned when initially wrapped around transducer 10 such that wire 14 exerts a compressive pre-stress on transducer 10. Wire 14 may be made of any suitable material selected from the group with mechanical properties exhibited by steel, titanium alloys, beryllium copper alloys, Nitinol™. Wire 14 may alternatively comprise a ribbon wire, or square wire, or a multi-strand wire. Wire 14 may alternatively comprise a high tensile strength elastic material such as epoxy-impregnated polyester, kevlar, glass or carbon fiber, in either a mono-filament or multi-filament form.

In a preferred aspect, the tensile stress in wire 14 is about 100 kpsi or higher. In one exemplary aspect of the invention,

the wire is a 0.001"×0.0003" Beryllium-Copper (BeCu) alloy ribbon wire under 0.3 lbs. tension, and transducer 10 is made of a PZT-8 ceramic having a 0.050" outer diameter, a 0.010" thickness wall, and a 0.315" length. In this exemplary aspect, the compressive pre-stress applied to the ceramic by the wrapped ribbon restraint is approximately 10 kpsi, which is comparable to the reported static tensile strength of PZT-8 ceramic at 11 kpsi, and significantly greater than the reported dynamic tensile strength of 5 kpsi.

Wire 14 is adapted to provide a compressive pre-stress on transducer 10, wherein the pre-stress is preferably maintained during the operation of transducer 10 by the resilience of the restraining wire.

In a preferred aspect, the compressive pre-stress exerted by wire 14 on transducer 10 is approximately equal to, or greater than, the tensile strength of the transducer. As will be explained, when the compressive pre-stress exerted on transducer 10 is approximately equal to the tensile strength of transducer 10, a doubling of output amplitude of transducer 10 is provided. In this preferred aspect of the invention, the stiffness of wire restraint 14 (or jacket 12) needed to provide this compressive pre-stress is only about 1/7 the stiffness of the transducer 10, therefore it does not appreciably restrain the motion of transducer 10, as follows.

The relationship between the stiffness of restraint 12 or 14 and the transducer 10 is established by considering that the modulus of elasticity "Y" of restraint 12 or 14 multiplied by the cross-sectional area of restraint 12 or 14, divided by the modulus of elasticity "Y" of transducer 10 multiplied by the cross-sectional area of transducer 10.

For example, using the BeCu ribbon at 19 Mpsi as wire 14, and PZT-8 ceramic as transducer 10, the modulus of elasticity "Y" of the BeCu ribbon is approximately 1.4 times the modulus of elasticity of the PZT-8 ceramic at 13 Mpsi, when the cross-sectional area of the BeCu ribbon is only about 1/10 that of the ceramic (1 ml ribbon thickness vs. 10 ml. transducer wall thickness). The relative stiffness of the restraint versus the transducer is then:

$$\frac{\text{stiffness}_{\text{restraint}}}{\text{stiffness}_{\text{transducer}}} = \frac{Y_{\text{restraint}} \cdot A_{\text{rest}}}{Y_{\text{transducer}} \cdot A_{\text{transducer}}} = \frac{19 \cdot 1}{13 \cdot 10} \approx \frac{1}{7}$$

In one exemplary aspect of the invention, the compressive pre-stress exerted by wire 14 on transducer 10 is approximately half-way between the compressive and tensile strengths of transducer 10, thereby providing the highest possible output without failure, (as will be explained).

To ensure that wire 14 provides a compressive pre-stress on transducer 10, it is also important to ensure that wire 14 does not simply unwrap, thereby losing its contact from the outer surface 13 of transducer 10. Accordingly, wire 14 is preferably glued or soldered against outer surface 13 of transducer 10. Alternatively, adjacent wraps of wire 14 may be soldered, welded, or glued together with wire 14 being secured to the outer surface 13 of transducer 10 by friction.

In one embodiment, wire 14 is welded, soldered, or glued to transducer 10 or to adjacent wraps of wire 14 only at opposite transducer ends 15 and 17. An advantage of welding wire 14 only at ends 15 and 17 is that this avoids relieving the stress in 10 wire 14 due to heating or melting. As such, a circumferential weld near each of ends 15 and 17 may be used to distribute the stress on the weld, with only a few turns of wire 14 near ends 15 and 17 being under reduced stress, with the (unheated) center turns of wire 14 exerting the compressive pre-stress on transducer 10. Alternatively, in another embodiment, wire 14 is welded or

adhesively attached along the entire length of **15** transducer **10** between ends **13** and **15**.

Wire **14** may optionally be a ribbon wire, which has the advantage of distributing stress favorably over surface **13** of transducer **10**, with the entire width of the ribbon in contact with the ceramic transducer **10**, instead of just a narrow strip where a round wire would be in tangential contact with the cylindrical transducer surface. Furthermore, since a ribbon wire provides the maximum amount of metal in a minimum profile, a ribbon wire permits the maximum restraint with minimum increase in the overall dimension of the restrained transducer. Furthermore, due to its narrow dimension in the radial direction, ribbon wire would experience much lower bending strain during the wrapping process as compared a round wire of comparable cross-sectional area per unit length. Another advantage of ribbon wire is that it is resistant to stress relief during the welding process in which wire **14** is attached to outer surface **13**, since the actual weld would only occupy a portion of the ribbon width leaving a large remaining portion to sustain tensile stress while the welding takes place.

In preferred aspects, wire **14** is selected from a material with an elongation at failure of greater than wire diameter/transducer radius, having the highest possible tensile strength. Alternatively, ribbon wire **14** is selected from a material with elongation at failure of greater than wire thickness transducer radius, having the highest possible tensile strength. In either case, the lowest possible modulus is desired so that there is a minimum of restraint exerted on transducer **10**. Examples of such materials include Beryllium Copper (BeCu) alloy **172**, with various tempers having tensile strengths of 100–240 kpsi and elongation of 1–10% , or various stainless steel alloys, or high strength Titanium alloys.

In a preferred aspect, wire **14** is wrapped over itself such that a multi-layer restraint is provided. An advantage of wrapping smaller diameter wire is that it will exhibit a lower bending stress, as compared to a larger diameter wire wrapped around the transducer.

In one preferred aspect, opposite ends **15** and **17** of transducer **10** may be electroded. Alternatively, in another preferred aspect, an inner surface **19** and outer surface **13** may instead be electroded.

In an alternate embodiment of the invention, the restraint used to exert a compressive pre-stress on the transducer comprises a jacket received over the transducer. Referring to FIGS. **3** and **4**, transducer **10** is shown surrounded by a restraint jacket **12** which is slipped thereover and exerts a compressive pre-stress, similar to that exerted by wire **14**, as was described above.

Jacket **12** may preferably be formed to maintain a compressive pre-stress on transducer **10** in a number of ways. In a first aspect, jacket **12** is initially formed with an inner diameter slightly less than the outer diameter of transducer **10**. Thereafter, jacket **12** is stretched radially by mechanical or thermal means to expand its inner diameter to a dimension such that it can just be slipped over transducer **10**, with transducer **10** received therein as shown in FIGS. **3** and **4**. After jacket **12** has been slipped over transducer **10**, jacket **12** will then be released such that it naturally contracts somewhat around outer surface **13** of transducer **10**. Consequently, jacket **12** exerts, and maintains, a compressive pre-stress on transducer **10** during its operation.

Jacket **12** may preferably be fabricated from a high tensile strength elastic material, including any of the exemplary materials set forth above with respect to wire **14**.

Alternatively, jacket **12** may be fabricated from a shape memory metal such as Nitinol™. In this aspect of the invention, a change in temperature will alter the size of jacket **12** such that it constricts around transducer **10** after having been received thereover. For example, a Nitinol™ alloy can be chosen to be Martensitic at the temperature of liquid nitrogen, and super-elastic in the temperature range from room temperature to body temperature and slightly above. The Nitinol™ alloy would be austenitic at elevated temperatures. Such a material can be fabricated as a thin wall tube with inner diameter slightly less than that of the transducer. For example, the ceramic transducer could have an outer diameter of 0.050" with a 0.010" wall thickness and a 0.315" length. The Nitinol™ tube could be fabricated with an inner diameter of 0.048" and a wall thickness of 0.002". When the Nitinol™ is cooled to liquid nitrogen temperature (–200° C.) the Nitinol™ becomes Martensitic and is relatively easily expanded to an inner diameter of 0.052", allowing it to be slipped over the outside of the ceramic transducer. When the Nitinol™ warms up to room temperature, it becomes super-elastic, and it attempts to recover to its original fabricated dimensions. The recovery is limited by the ceramic, but the super-elastic alloy applies a compressive pre-stress to the ceramic, thereby preventing premature tensile failure of the ceramic.

When using either jacket **12** or wire **14** as the restraint on transducer **10**, such restraint will preferably have a high tensile strength so that only a thin layer of the restraint material will be adequate, yet also have to have a low stiffness such that it would not unduly restrain the ceramic transducer **10**.

When using either a wire restraint (FIGS. **1** and **2**) or a jacket restraint (FIGS. **3** and **4**), the restraint is preferably received within an outer coating **16**, as shown in FIG. **5**. Outer coating **16** may preferably comprise a composite polymer, which operates to dampen longitudinal vibrations and provide an electrical insulating layer. In an exemplary aspect, outer coating **16** comprises a high strength thin wall polymer such as 0.001" thick polyester or nylon polymer, attached to jacket **12** by a high strength adhesive, preferably having at least 500 psi shear strength.

The present invention also sets forth systems for wrapping wire **14** around transducer **10** such that wire **14** remains in tension. Referring to FIG. **6**, two strands of wire **14** are shown being wrapped simultaneously around transducer **10** as transducer **10** is rotated in direction R. In this system, a pair of equal weights W1 and W2 keep wire **14** under tension as wire **14** passes over pulleys P1 and P2. Since W1 and W2 are equal, the wires **14** will not produce any net bending stress on the transducer **10** which could cause it to break during the manufacturing process. Alternatively, weight W2, pulleys P1 and P2 and one wire **14** may be eliminated to simplify the wrapping fixture. In this case, the transducer **10** must be strong enough to resist the bending stress created by the tensioned wrapping wire **14**.

Longitudinally extending bore **11**, as seen in FIGS. **1** to **5**, may preferably be air filled. Advantages of an air-filled bore include the fact that ultrasound energy can not be transmitted thereacross. Instead, all of the ultrasound energy emitted by transducer **10** will advantageously be reflected off of inner surface **19**, and directed radially outwardly, thereby increasing the therapeutic effectiveness of transducer **10**. Another advantage of air-filled bore **11** is that it can be used for passage of a guidewire therethrough.

FIG. **7A** shows an embodiment of the present invention in which jacket **12** is made of Nitinol™, with an electrical lead

22 passing under outer covering 16 and through a hole 9 passing through jacket 12 such that an electrical lead 22 may be attached to electroded outer surface 13 of transducer 10. Similarly, an electrical lead 24 is attached to the inner surface 19 of transducer 10 as shown. FIG. 7B shows electrical lead 22 connected to electroded outer surface 13 by way of a solder tab 18. FIG. 7C shows electrical lead 22 soldered directly to electrically conductive wire 14, which is in direct contact with electroded outer surface 13 of transducer 10.

In a preferred aspect, wire 14 is soldered at ends 15 and 17 to prevent unwrapping from transducer 10. The outer electrode connection may be made by soldering directly to wire 14. As such, transducer 10 can be wrapped all the way from end-to-end with no unwrapped segment required for lead attachment.

FIG. 8 illustrates a tool for expanding jacket 12 such that it can be received over transducer 10. The tool comprises a split mandrel 20 and a tapered conical wedge 21. Conical wedge 21 is inserted into a bore passing through split mandrel 20 such that jacket 12 can be expanded. In a preferred aspect, jacket 12 is made of Nitinol™, and the insertion of wedge 21 into mandrel 20 is preferably done at a cool temperature such that when Nitinol™ jacket 12 returns to a warmer temperature, it will tend to retract radially inwards. In an exemplary aspect, Nitinol™ jacket 12 will have a thickness of approximately 0.002", offering an improved compromise in terms of strength and low restraint.

In preferred aspects, transducer 10 will be operated at a low temperature rise. Such low temperature rise can be achieved by maintaining a low duty cycle, or alternatively by providing a cooling flow such as a saline infusion over transducer 10 during its operation. Preferably, a temperature rise of less than 5° C. will be achieved. Preferably, the fluid could be introduced through an annular space between transducer 10 and a polyimide guidewire sleeve. Temperature monitoring by a catheter mounted thermistor or thermocouple can also be used.

Referring to FIG. 9, an alternate transducer system is provided with transducer 30 comprising alternating annular sections of PZT ceramic 32 and polymer 34. Transducer 30 is ideally suited to avoiding longitudinal failure. In accordance with the present invention, transducer 30 may be substituted for transducer 10 in any of the above described embodiments of the present invention. For example, transducer 30 is preferably restrained by a wire 14 wrapped therearound, or a jacket 12 slipped thereover, the restraint used in turn being received within outer covering 16, as described.

As stated above, the strength of the compressive pre-stress provided by wire 14 or jacket 12 on transducer 10 is at least approximately equal to the tensile strength of the transducer material and more preferably, approximately ½ way between the tensile and compressive strengths of the material. This is explained as follows.

Referring to FIG. 10, a stress vs. time plot for an unrestrained transducer is shown. Acoustic vibrations in the transducer are characterized by oscillation in the stress. In a conventional transducer, without a pre-stress, the stress oscillates around zero, alternating between compressive (positive) stress and tensile (negative) stress.

Since piezo-electric ceramic materials typically have much higher compressive strengths compared to their tensile strengths, compressive pre-stress permits higher acoustic amplitude without subjecting the ceramic to tensile stress

beyond its limit. Specifically, the tensile strength of the transducer material is shown by line 50 and the compressive strength of the transducer material is shown by line 52. (As can be seen, line 50 is closer to zero than line 52, thus indicating that the transducer is more likely to fail in tension than in compression). If the stress during one of the cycles of oscillation exceeds the tensile strength of the ceramic, then the transducer will fracture. Accordingly, when operating an unrestrained transducer, the maximum tensile stresses will equal the maximum compressive stresses. Accordingly, the maximum peak-to-peak amplitude of the oscillations in the stress (i.e.: the difference between lines 50 and 70) will be double the tensile strength (i.e.: the difference between zero and line 50) of the transducer material.

FIG. 11 shows a stress vs. time plot for a transducer with a restraint wrapped therearound. In this aspect of the invention, the compressive pre-stress (labeled as distance "B"), (ie: the difference between zero and line 54) is equal to the tensile strength (labeled as distance "A"), (i.e.: the difference between zero and line 50) of the transducer material. Thus, line 54 is at the same level as line 70. As can be seen, the application of such a compressive pre-stress to the transducer results in a doubling of the maximum peak-to-peak amplitude of oscillation in the stress relative to that of a comparable unrestrained transducer, (i.e.: the difference between line 56 and zero is twice the difference between line 54 and zero).

FIG. 12 shows a stress vs. time plot for a transducer with a restraint wrapped therearound, operating at optimal output. In this aspect of the invention, the compressive pre-stress applied by the restraint (line 58) is set to be ½ way between the tensile strength (line 50) and the compressive strength (line 52) of the transducer material. As can be seen, the application of such a compressive pre-stress on the transducer effectively maximizes the peak-to-peak amplitude of the oscillation in the stress to a level corresponding to the difference between compressive strength (line 52) and the tensile strength (line 50).

Accordingly, in preferred aspects of the invention, the compressive pre-stress applied to the transducer by the restraint is at least equal to, and preferably greater than, the tensile strength of the transducer. More preferably, the compressive pre-stress applied to the transducer by the restraint is of an amplitude greater than the tensile strength of the material and not exceeding ½ way between the tensile and compressive strengths of the material. In an optimal aspect of the invention, the compressive pre-stress is equal to a level ½ way between the tensile and compressive strengths of the material.

In another preferred aspect of the invention, the compressive pre-stress applied to the transducer is sufficient to permit reliable operation at the desired acoustic output amplitude, without permitting tensile failure of the ceramic and without requiring an unnecessarily stiff or bulky restraint.

As such, FIGS. 11 and 12 provide illustrations of how compressive pre-stress permits higher amplitude acoustic vibrations without stress exceeding the tensile strength limit of the ceramic compressive strength of ceramic.

Lastly, FIG. 13 is an illustration of a plurality of the present cylindrically shaped high output ultrasound transducers 10, with wrapped wire restraint 14 thereover, as previously described herein, mounted along a flexible catheter 60 with spacers 62 disposed therebetween. Spacers 62 may be formed from a flexible polymer material so as to permit catheter 60 to flex between the rigid transducer (10)

segments. Outer covering **16** may preferably be formed from a flexible polymer which bonds to jacket **12**, and provides a smooth outer surface for catheter **16**. A plurality of optional bushings **64** are disposed between transducers **10** and spacers **62**, forming an air gap **65** adjacent the inner surface **66** defining lumen **67** through which guide wire **68** passes, as shown. In a preferred aspect, the guidewire lumen **67** is lubricious and flexible and contains guidewire **68** and has a fluid (such as saline) passing therethrough to provide cooling for transducers **10**. Air gap **65** operates to direct the ultrasound energy emitted by transducers **10** radially outwardly, by inhibiting radially inward ultrasound emissions. A preferred material for guidewire lumen **67** is high density polyethylene.

What is claimed is:

1. A therapeutic ultrasound energy delivery system, comprising:

a probe for contact on or in a target location in a patient's body;
 a vibrational transducer; and
 a restraint disposed around the transducer, wherein the restraint exerts a compressive pre-stress on the transducer.

2. The therapeutic ultrasound energy delivery system of claim **1**, wherein the compressive pre-stress on the transducer is at least equal to the tensile strength of the transducer, wherein the restraint inhibits tensile failure of the vibrational transducer at high acoustic output.

3. The therapeutic ultrasound energy delivery system of claim **1**, wherein the value of the compressive pre-stress on the transducer is greater than value of the tensile strength of the transducer and less than one-half of the sum of the values of the compressive strength and the tensile strength of the transducer.

4. The therapeutic ultrasound energy delivery system of claim **1**, wherein the value of the compressive pre-stress on the transducer is approximately equal to one-half of the sum of the values at the compressive strength and the tensile strength of the transducer.

5. The therapeutic ultrasound energy delivery system of claim **1**, wherein the transducer is cylindrically shaped.

6. The therapeutic ultrasound energy delivery system of claim **1**, wherein the restraint maintains the compressive pre-stress during operation of the transducer.

7. The system of claim **1**, wherein the restraint comprises: a jacket slipped over the transducer.

8. The system of claim **7**, wherein the jacket is stretched to an expanded diameter to be received over the transducer.

9. The system of claim **7**, wherein the jacket is formed of a shape memory metal.

10. The system of claim **1**, wherein the restraint comprises:

a wire wrapped around the transducer.

11. The system of claim **10**, wherein the wire is a monofilament or multifilament polymer.

12. The system of claim **10**, wherein the wire is wrapped around the transducer under tension.

13. The system of claim **10**, wherein the wire is a ribbon wire.

14. The system of claim **10**, wherein the wire is soldered to the ultrasound transducer.

15. The system of claim **10**, wherein the wire is welded to the ultrasound transducer.

16. The system of claim **15**, wherein the wire is welded to opposite longitudinal ends of the transducer.

17. The system of claim **15**, wherein the wire is welded to the transducer along the length of the transducer.

18. The system of claim **10**, wherein the wire is glued to the ultrasound transducer.

19. The system of claim **1**, wherein the transducer is selected from the group consisting of a piezoelectric ceramic, an electrostrictive ceramic and a piezoelectric crystal.

20. The system of claim **1**, wherein the transducer is made of PZT-8 or PZT-4 ceramic material.

21. The system of claim **1**, wherein the restraint is made of a high tensile strength elastic material selected from the group consisting of steel, titanium alloys, beryllium copper alloys, nickel-titanium alloys, and epoxy impregnated kevlar, polyester or carbon fiber.

22. The system of claim **1**, further comprising:

a composite polymer outer covering disposed around the outside of the restraint.

23. The system of claim **22**, wherein the composite polymer outer covering comprises a combination of materials selected from the group consisting of a high strength epoxy, cyano-acrylate, polyester, PVDF, Pebax, nylon or polyethylene.

24. The system of claim **1**, wherein the ultrasound transducer has a central air-filled bore passing longitudinally therethrough.

25. The system of claim **24**, further comprising:

a first electrode disposed on the outer surface of the transducer; and

second electrode is disposed on the inner surface of the transducer.

26. The system of claim **1**, further comprising:

first and second electrodes respectively disposed on opposite longitudinal ends of the transducer.

27. The system of claim **1**, wherein the transducer comprises a series of alternating annular shaped polymer and piezoelectric ceramic rings having inner and outer surfaces.

28. The system of claim **27**, further comprising first and second electrodes attached to inner and outer surfaces of the transducer.

29. The system of claim **27**, further comprising electrodes attached to opposite longitudinal ends of each of the piezoelectric ceramic rings.

30. A method for delivering vibrational energy to a patient, comprising:

introducing a vibrational transducer to the patient;

energizing the transducer to deliver vibrational energy to the patient, wherein the transducer is constrained by a restraint which provides a compressive pre-stress which permits the transducer to operate at an acoustic output having a value which is greater than the value of acoustic output that would have been achievable without the restraint.

31. The method of claim **30**, wherein the value of the compressive pre-stress on the transducer is at least equal to the value of the tensile strength of the transducer.

32. The method of claim **30**, wherein the value of the compressive pre-stress on the transducer is greater than the value of the tensile strength of the transducer and less than one-half of the sum of the values of the compressive strength and tensile strength of the transducer.

33. The method of claim **30**, wherein the value of the compressive pre-stress on the transducer is approximately equal to one-half of the sum of the values of between the compressive strength and the tensile strength of the transducer.

34. The method of claim **30**, wherein exerting the compressive pre-stress comprises wrapping a tensioned wire around the transducer.

13

- 35. The method of claim 30, wherein exerting a compressive pre-stress on the ultrasound transducer comprising stretching a jacket to a diameter sufficient to be received over the transducer and inserting the transducer into the jacket.
- 36. The method of claim 30, further comprising:
providing a composite polymer outer cover wrapped around the restraint.
- 37. The method of claim 30, further comprising:
operating the transducer with first and second electrodes respectively disposed on opposite longitudinal ends of the transducer.
- 38. The method of claim 30, wherein the transducer has a central air-filled bore passing longitudinally therethrough defining an inner surface and outer surface of the transducer, further comprising:
operating the transducer with first and second electrodes respectively disposed on the inner and outer surfaces of the transducer.
- 39. The method of claim 30, further comprising:
cooling an inner bore in the transducer with a fluid flow.
- 40. The method of claim 39, wherein the fluid flow is a saline infusion.
- 41. The method of claim 30, wherein the vibrational transducer is operated at a Mechanical Index (MI) of at least 1.9.

14

- 42. The method of claim 30, wherein the vibrational transducer is operated at a frequency of at least 500 KHz.
- 43. The method of claim 30, wherein the vibrational transducer is operated at a frequency not exceeding 3 MHz.
- 44. A therapeutic ultrasound catheter system comprising:
a catheter;
a plurality of vibrational transducers disposed along the length of the catheter;
a restraint disposed around each transducer, wherein each restraint exerts a compressive pre-stress on one of the transducer, wherein the restraint inhibits tensile failure of the vibrational transducer at high acoustic output;
and
a plurality of spacers disposed between each of the successive vibrational transducers.
- 45. A method of treating arterial restenosis, comprising:
inserting the catheter system of claim 44 into a patient's artery; and
emitting ultrasound energy from the plurality of vibrational transducers.

* * * * *