



(19) **United States**

(12) **Patent Application Publication**
Schuler et al.

(10) **Pub. No.: US 2014/0047664 A1**

(43) **Pub. Date: Feb. 20, 2014**

(54) **DIRECTED HYDROBURST SYSTEM FOR CLEANING FLAT SCREENS**

Publication Classification

(71) Applicant: **Bilfinger Water Technologies Inc.**, New Brighton, MN (US)

(51) **Int. Cl.**
B01D 29/66 (2006.01)

(72) Inventors: **Tom Schuler**, Bethel, MN (US);
Michael Ekholm, Minneapolis, MN (US)

(52) **U.S. Cl.**
CPC **B01D 29/661** (2013.01)
USPC **15/316.1**

(73) Assignee: **Bilfinger Water Technologies Inc.**, New Brighton, MN (US)

(57) **ABSTRACT**

(21) Appl. No.: **13/964,725**

A screen intake system has a body with an open end and a chamber. A flat screen is disposed at the open end of the body. To keep the screen clear of debris, an airburst system has pipes disposed in the chamber. The pipes dispose parallel to one another adjacent the flat screen, and each of the pipes has orifices in a side facing the flat screen. Directors are disposed along the backs of the pipes in a lattice, and each of the directors has a channel in which the pipe disposes. Compressed air released by valves from a tank dispersed from the pipe's orifices. Each of the directors directs the resulting water/airburst from the orifices toward the adjacent flat screen to clear it of debris.

(22) Filed: **Aug. 12, 2013**

Related U.S. Application Data

(63) Continuation of application No. 13/228,228, filed on Sep. 8, 2011, now Pat. No. 8,505,154.

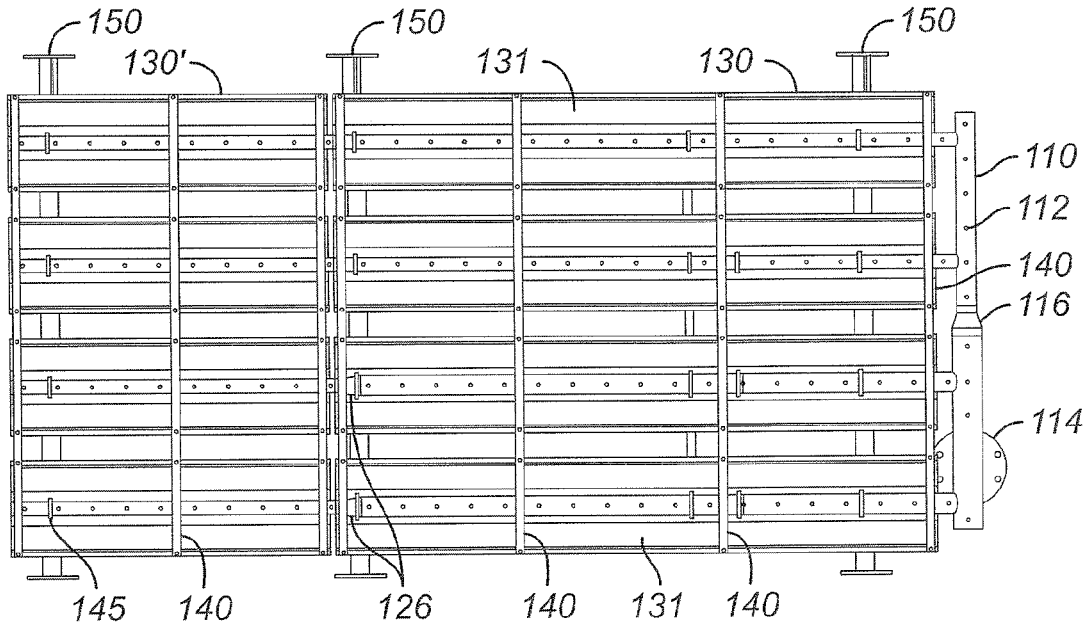

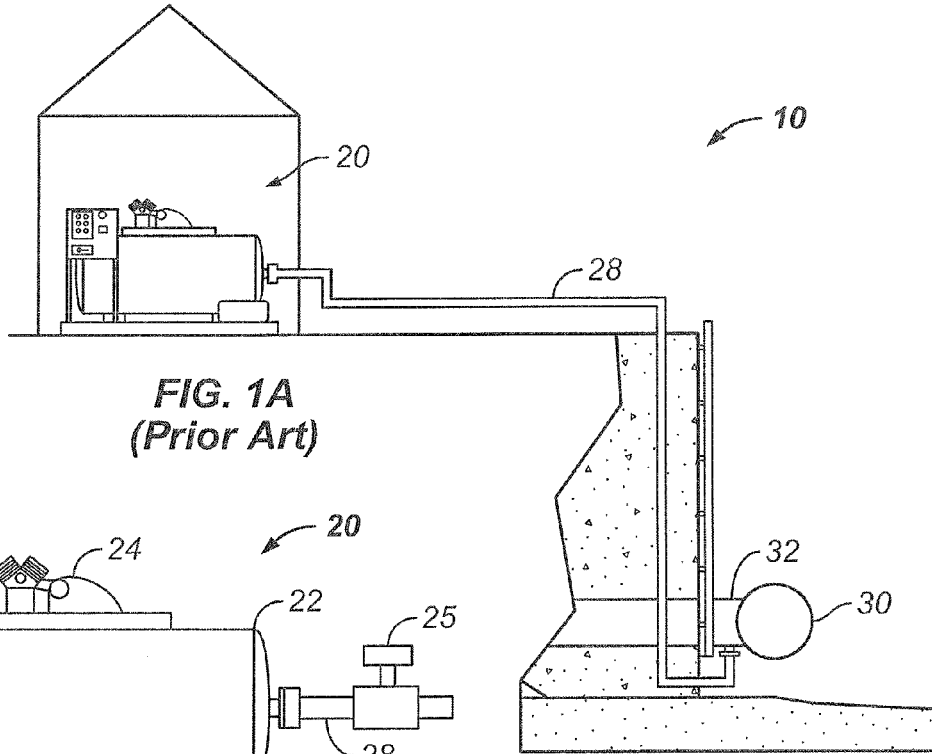

FIG. 1A
(Prior Art)

FIG. 1B
(Prior Art)

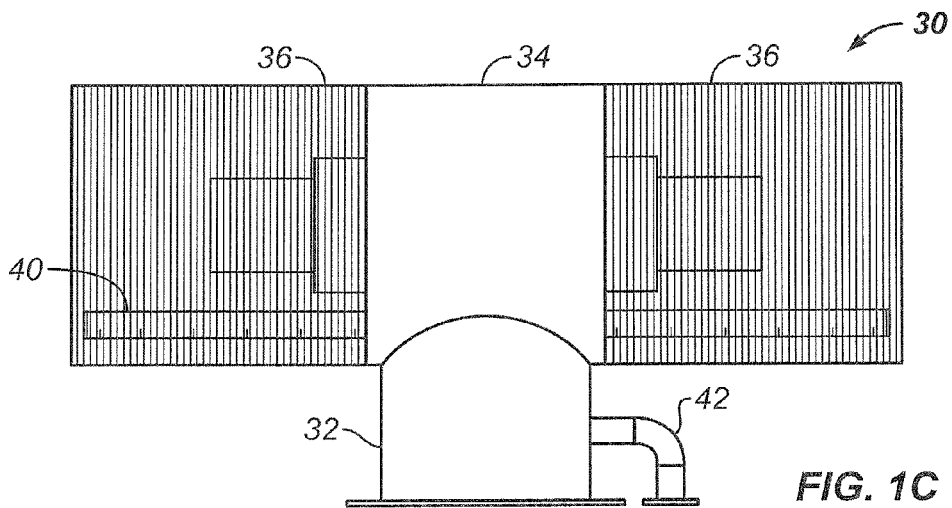

FIG. 1C
(Prior Art)

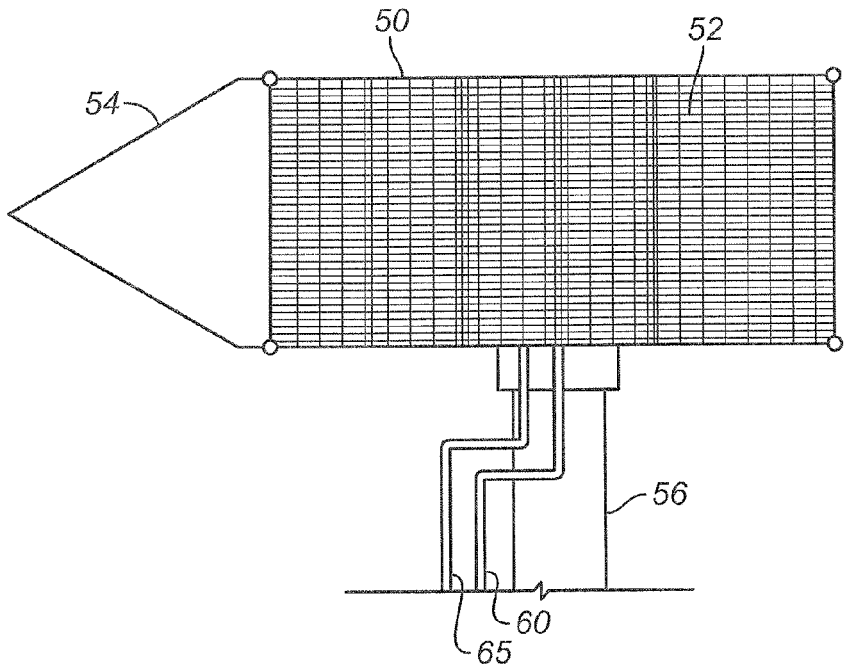

FIG. 2A
(Prior Art)

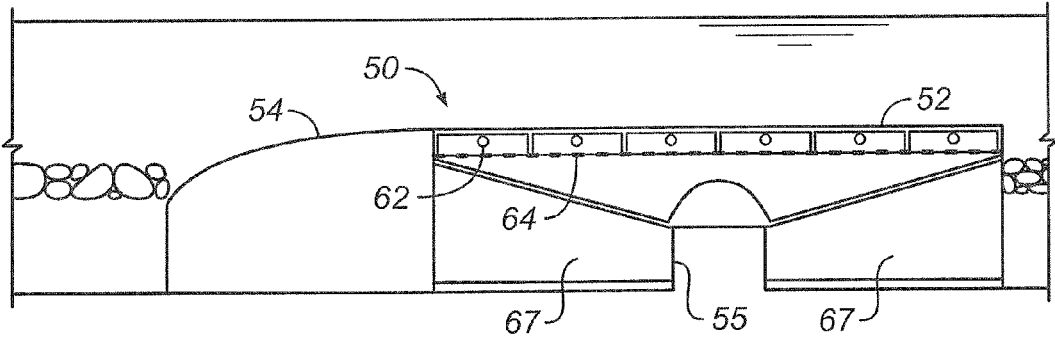

FIG. 2B
(Prior Art)

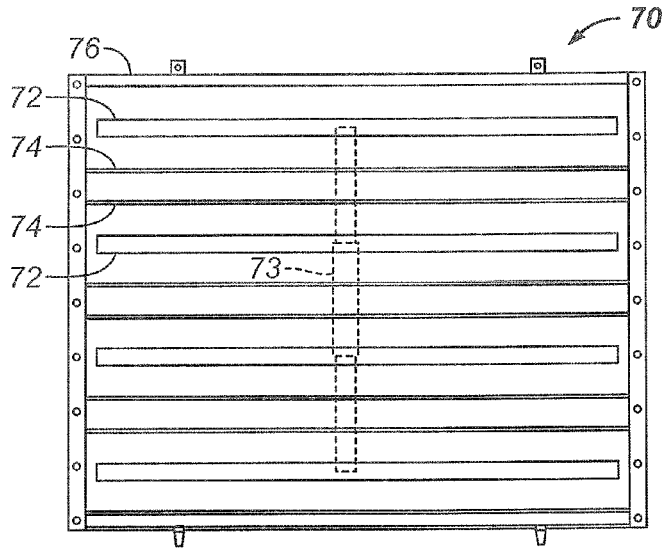

FIG. 3A
(Prior Art)

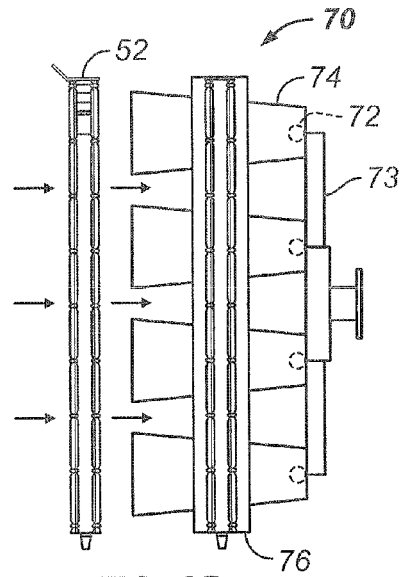

FIG. 3B
(Prior Art)

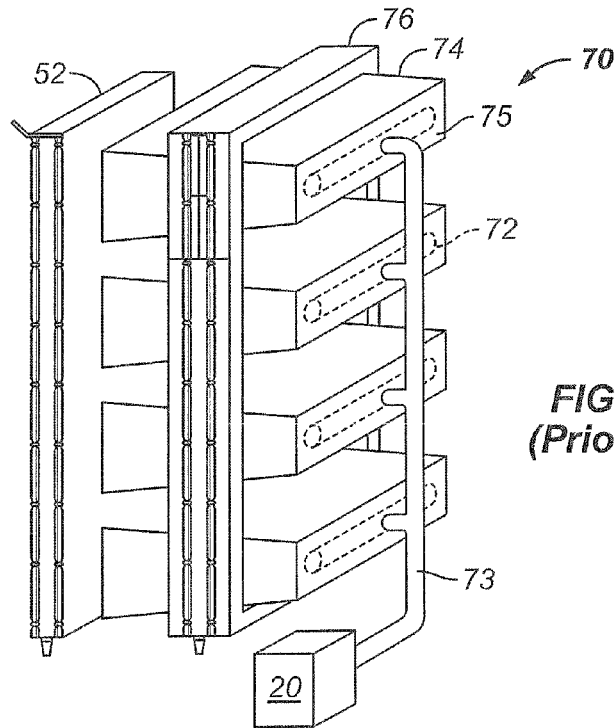

FIG. 3C
(Prior Art)

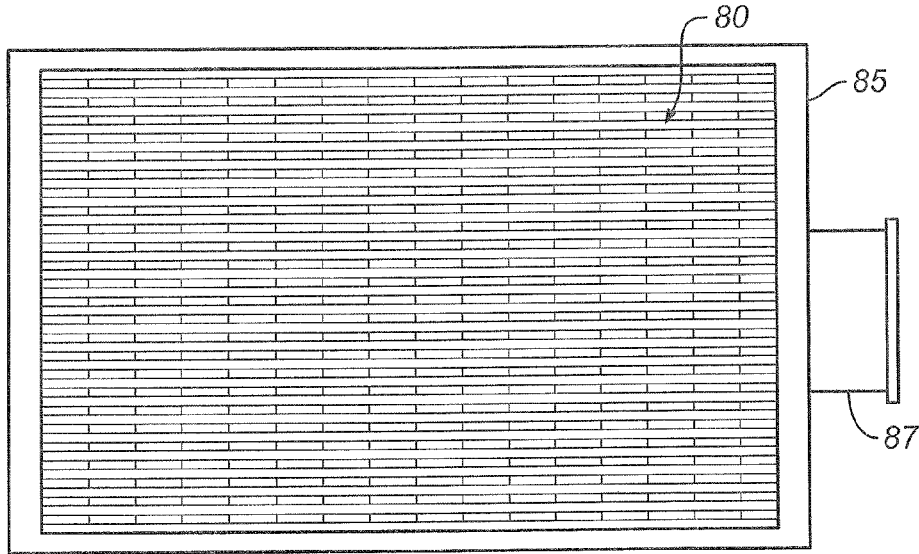

FIG. 4A

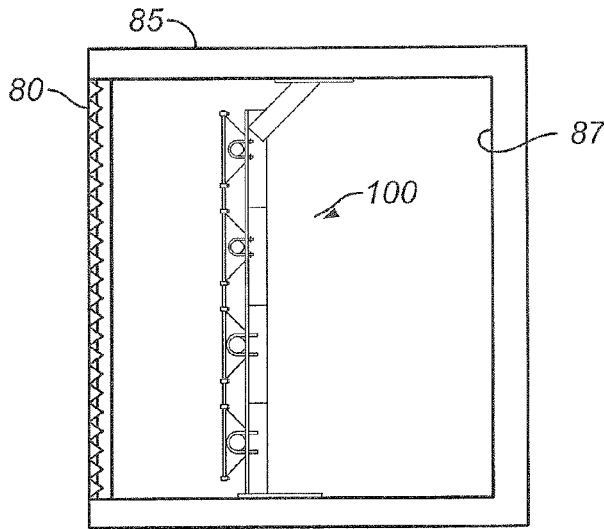

FIG. 4B

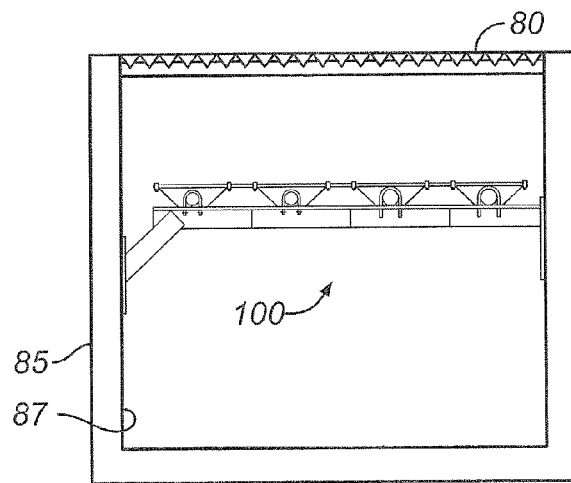

FIG. 4C

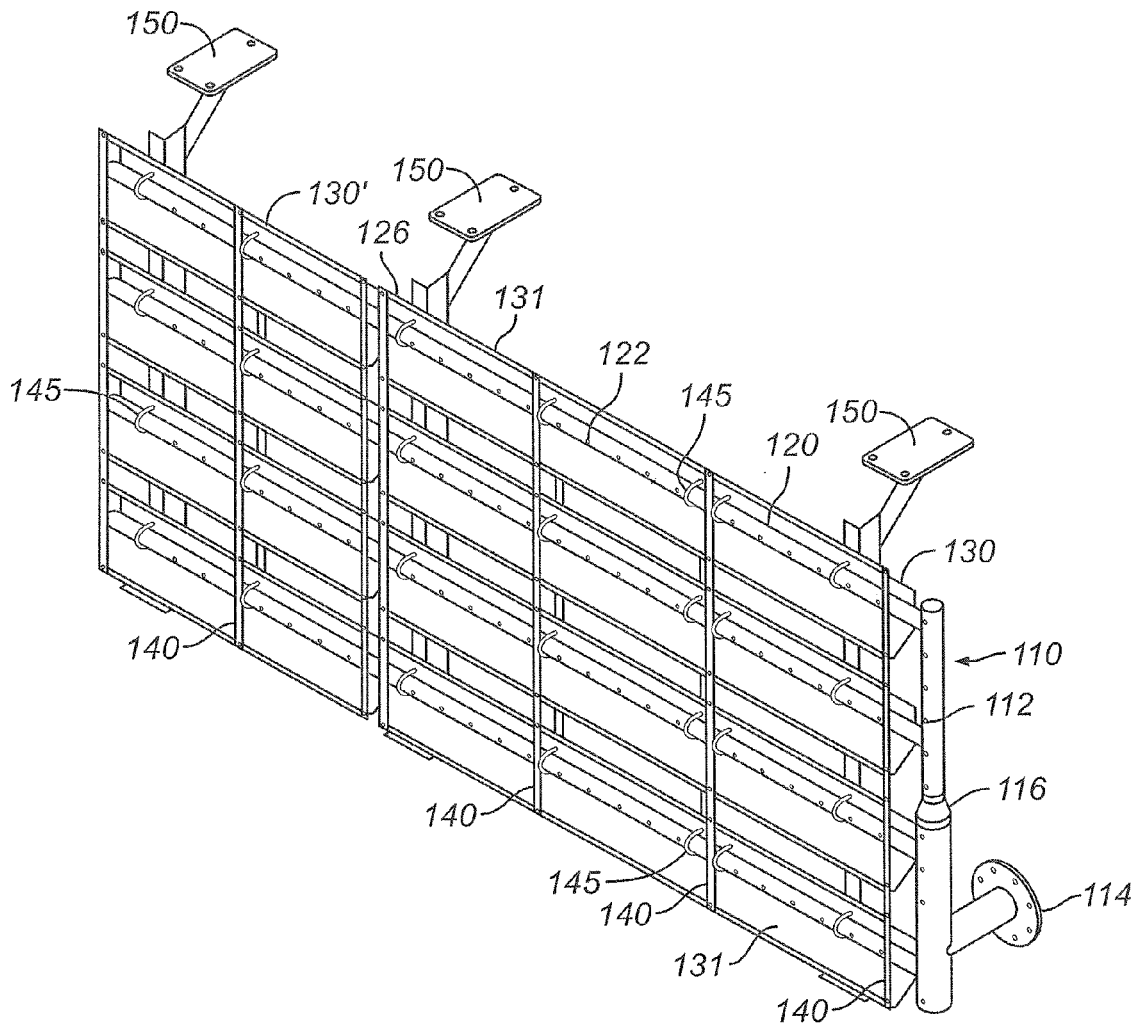

FIG. 5A

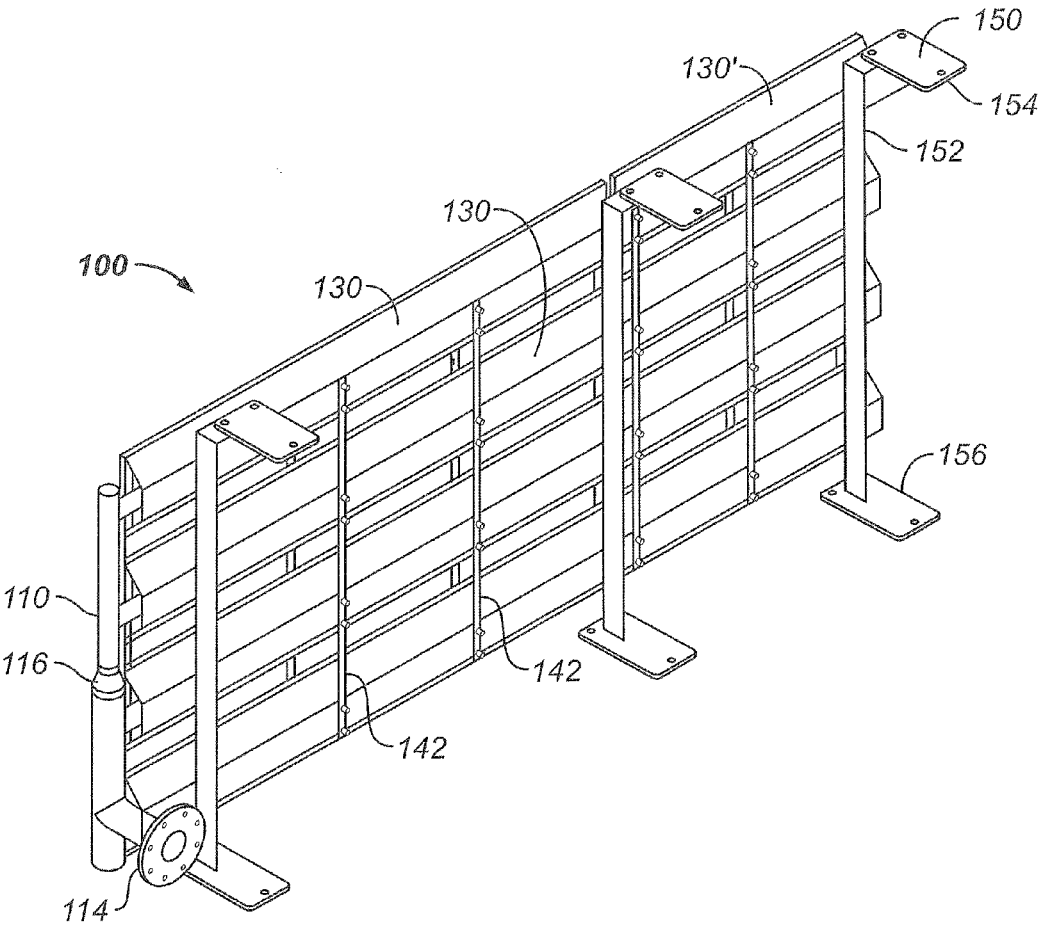

FIG. 5B

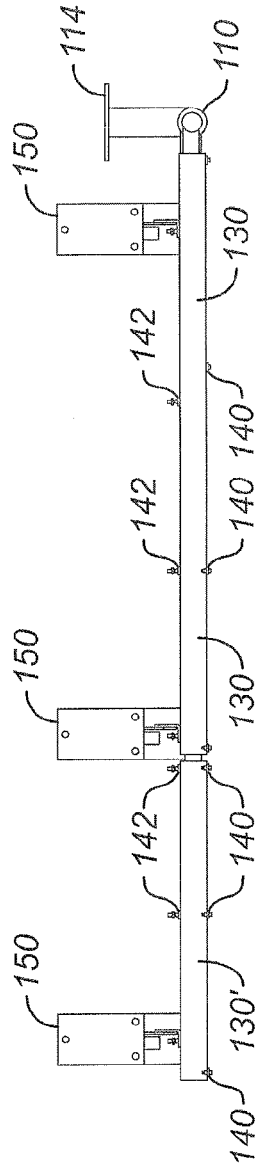

FIG. 6D

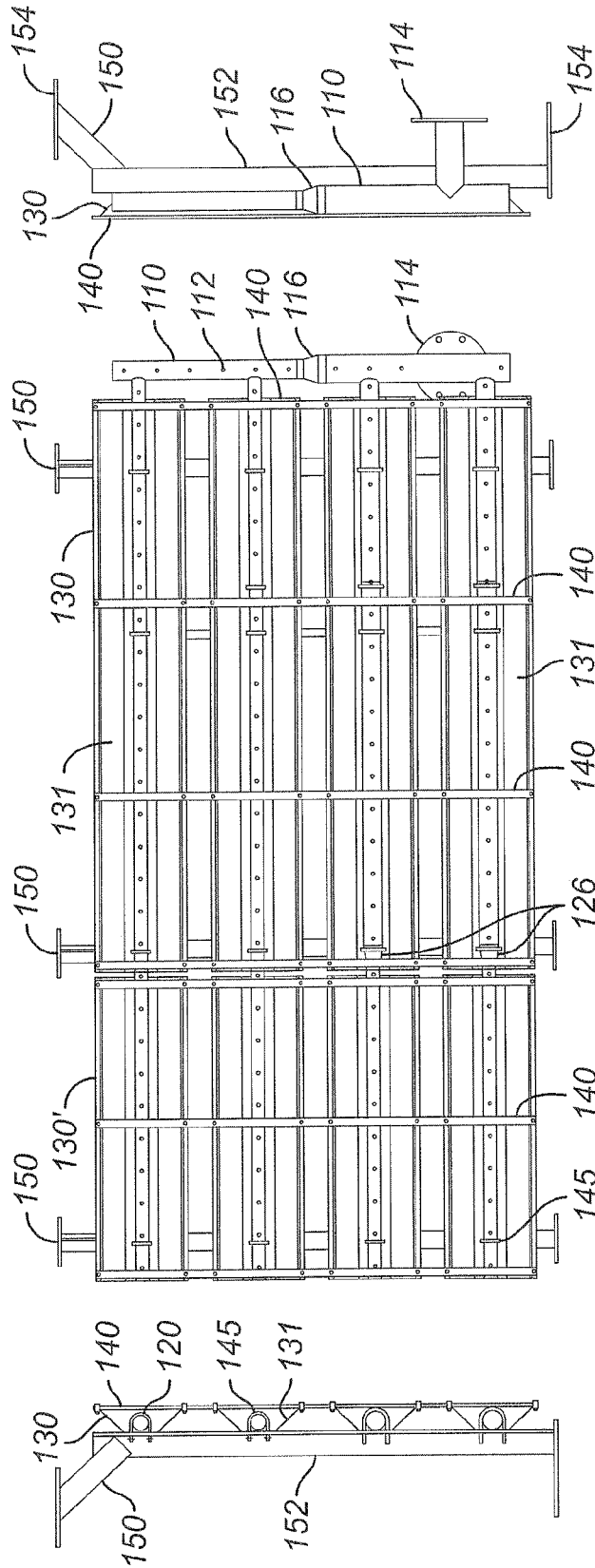

FIG. 6C

FIG. 6A

FIG. 6B

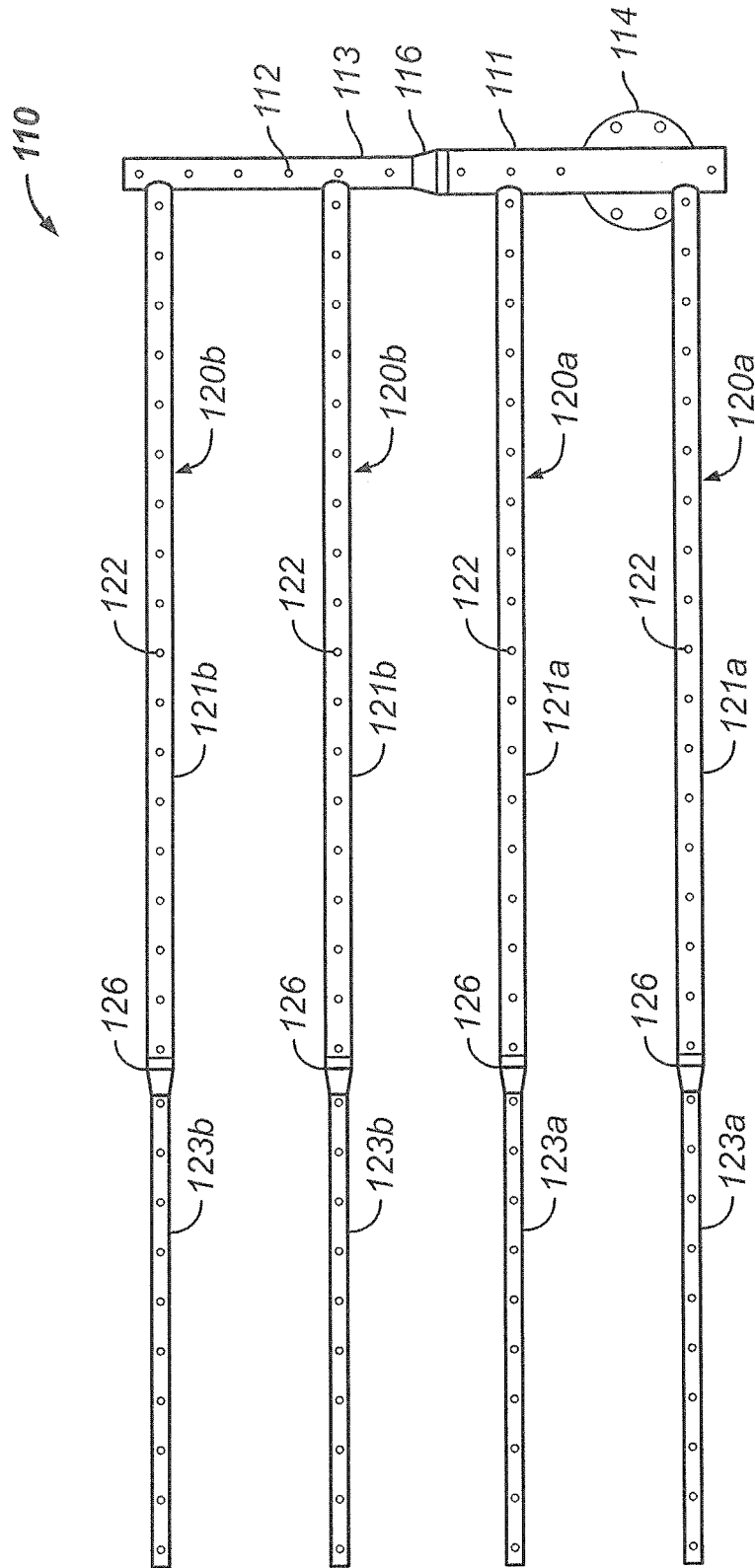

FIG. 7

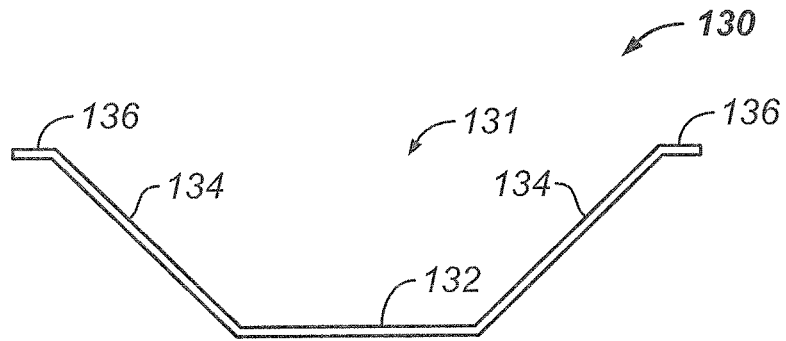

FIG. 8A

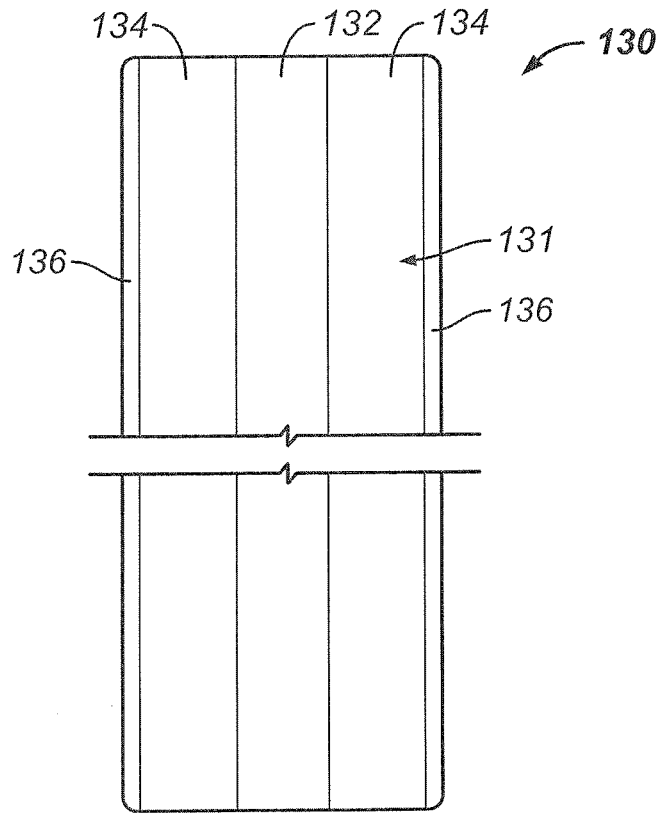

FIG. 8B

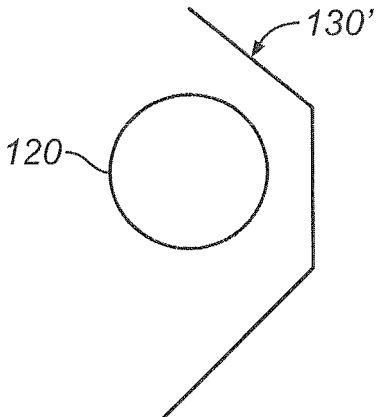

FIG. 8C

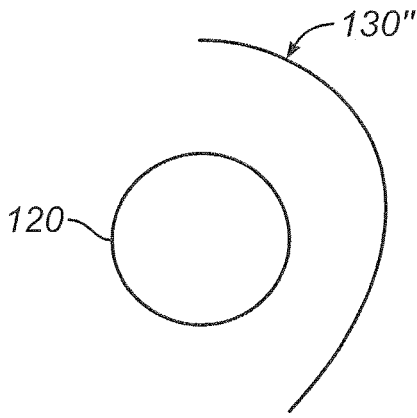

FIG. 8D

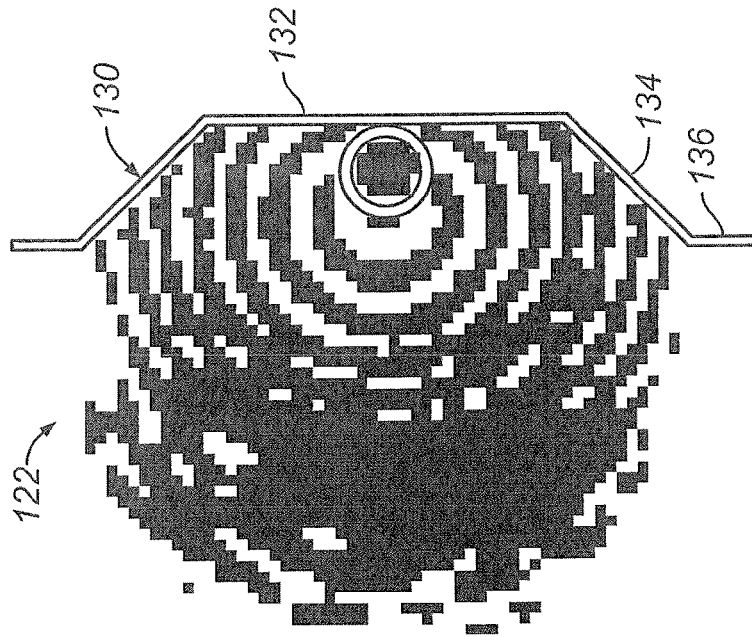

FIG. 9A

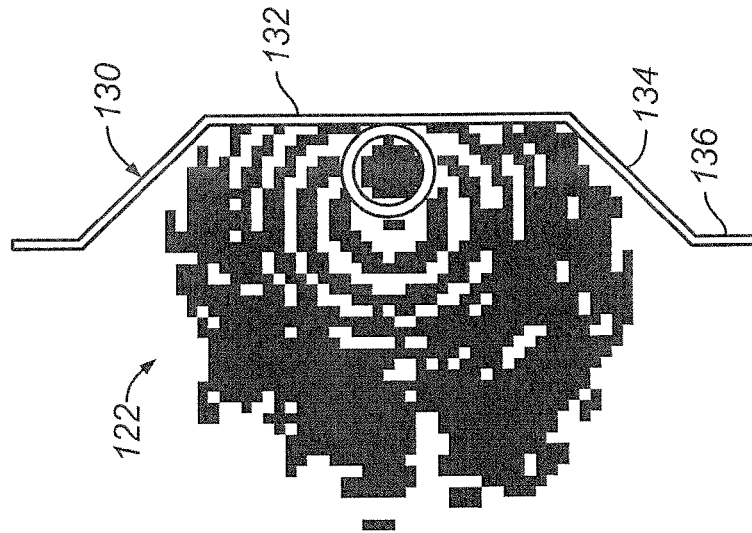

FIG. 9B

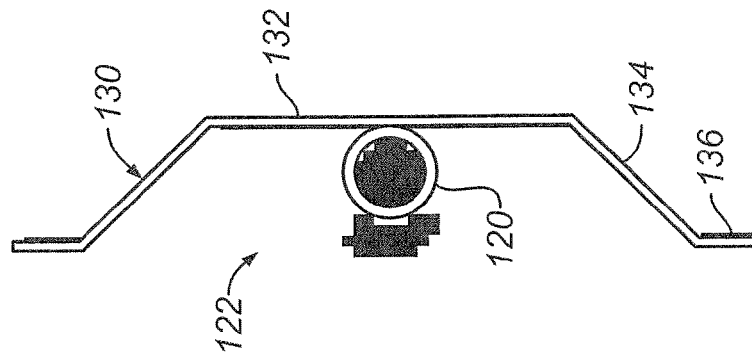

FIG. 9C

DIRECTED HYDROBURST SYSTEM FOR CLEANING FLAT SCREENS

CROSS-REFERENCE TO RELATED APPLICATION

[0001] This application is a continuation of U.S. patent application Ser. No. 13/228,228, filed Sep. 8, 2011, the contents of which are hereby incorporated by reference in their entirety.

BACKGROUND

[0002] Water intake systems use various types of screens and barriers, and several systems have been developed to clean debris from the screens. For example, mechanical systems that use moving brushes have been used to clear screens of debris. In addition, removable forms of screens have been used in many locations to overcome cleaning issues.

[0003] In other implementations, screen cleaning systems can use bursts of air directed from a manifold to clean the screen of debris. For example, Johnson Screen's Hydroburst System is one system used for cleaning cylindrical intake screens. FIGS. 1A-1C show a water intake system 10 having a hydroburst system 20 according to the prior art. The hydroburst system 20 is used for implementations where the intake screen 30 may need regular cleaning when exposed to debris or when the screen 30 is difficult to access. When operated, the hydroburst system 20 flushes the debris away from the screen's surface by releasing a large volume of compressed air inside the screen 30 in a quick burst.

[0004] As shown in FIGS. 1A-1B, the hydroburst system 20 has a receiver tank 22 that stores compressed air and has a compressor 24 that charges the tank 22 with the compressed air. Distributor piping 28, valves 25, and the like couple the tank 22 to a header in the screen 30. Finally, a control panel 26 controls operation of the system 20.

[0005] The cylindrical screen intake 30 shown in FIG. 1C has a tee configuration with two screens 36 on opposing ends of a central body 34. A water outlet 32 connects from the central body 34 for connecting to other components of the water intake system 10. Air backwash headers 40 disposed in the screens 36 connect to an inlet pipe 42 that receives air from the hydroburst system 20. When an airburst communicated from the hydroburst system 20 reaches the headers 40, the resulting burst of air/water can clean the cylindrical screens 36 of debris.

[0006] Cleaning a screen with an airburst can be more difficult when the screen is flat. Such flat screens can be used for a number of applications, including water intake systems and fish diversion in dam and river systems to protect fish from hydroelectric turbines and pumps. Typically, the flat screens for these applications have a low-suction velocity to protect fish and other aquatic life. Yet, debris may still be able to collect on the screens.

[0007] One solution by Montgomery Watson Engineering for clearing debris from a flat screen is shown in FIGS. 2A-2B. A water intake module 50 buries in a bed of a waterway so that a portion of the module 50 sticks above the bed. The module 50 has a nose shield 54 at its upstream end. A supply pipe 56 runs from the module 50 to a water intake system, and a cleaning air pipe 60 and a buoyancy air pipe 65 run from the module 50 to components of an air supply system.

[0008] Internally, the module 50 contains flat fish screens 52, flow control slats 64, airburst cleaning pipes 62, floatation tanks 67, and a supply pipe connection 55. The flat screens 52, slats 64, and airburst pipes 62 situate at the top of the module 50, while the floatation tanks 67 situate at the bottom. The cleaning air pipe 60 of FIG. 2A connects to the airburst pipes 62 shown in FIG. 2B, and the buoyancy air pipe 65 of FIG. 2A connects to the floatation tanks 67 shown in FIG. 2B.

[0009] During use, water flows downward through the flat screens 52 and past the slats 64 into the module's collection chamber where the water can then travel to the supply pipe 56. The airburst pipes 62 are horizontally arranged PVC pipes located between the flat screens 52 and slats 64. These pipes 62 have small holes and distribute an airburst for cleaning the flat screens 52 when a burst of air is supplied. The slats 64 and pipes 62 have been used with horizontal modules 50 as shown in FIG. 2B, but they have also been used for vertical modules (not shown).

[0010] Another solution from Johnson Screens for clearing debris from a flat screen is shown in FIGS. 3A-3C. Here, a horizontal manifold 70 is used to clean a flat screen 52. The manifold 70 has distributor pipes 72 enclosed by troughs 74. A manifold frame 76 couples to the screen 52 or anchors by suitable stabilizing means downstream of the screen 52. Either way, the manifold frame 76 supports the deep troughs 74, which facilitate airflow from a backwash system 20 to the screen 52. As best shown in FIG. 3C, the troughs 74 have back panels 75, which can be solid as shown. Alternatively, the back panels 75 can be perforated or may not be present so water can flow through the deep troughs 74.

[0011] To provide the airflow, a conduit 73 couples from the backwash system 20 to each distributor pipe 72 enclosed in the troughs 74. Each distributor pipe 72 has a plurality of orifices (not shown) to direct a burst of air outwards toward the screen 52. When the backwash system 20 produces an airburst, for example, the air is directed from the pipes 72 and troughs 74 to the opposing screen 52 to clear debris. Water flow through the screen 52 and between the troughs 74 is shown by arrows.

[0012] Although the manifold 70 of FIGS. 3A-3C and other prior art systems may be effective, constructing such a trough-type manifold can be complicated and cost prohibitive for some implementations. Therefore, it would be useful for operators to be able to clean flat type screens effectively with an airburst system. The subject matter of the present disclosure is directed to overcoming, or at least reducing the effects of, one or more of the problems set forth above.

SUMMARY

[0013] A screen intake system has a body with an open end and a chamber. A flat screen is disposed in the open end of the body. To keep the screen clear of debris, an airburst system has pipes disposed in the chamber. The pipes dispose parallel to one another adjacent the flat screen, and each of the pipes has orifices in a side facing the flat screen. Directors dispose along the backs of the pipes, and each of the directors has a channel in which the pipe disposes. Compressed air is released by valves from a tank, and the airburst is dispersed from the pipe's orifices. Each of the directors directs the resulting water/airburst from the orifices toward the adjacent flat screen to clear it of debris.

[0014] The foregoing summary is not intended to summarize each potential embodiment or every aspect of the present disclosure.

BRIEF DESCRIPTION OF THE DRAWINGS

[0015] FIG. 1A illustrates a water intake system according to the prior art.

[0016] FIG. 1B illustrates components of the system in more detail.

[0017] FIG. 1C shows a cylindrical screen intake with manifold according to the prior art.

[0018] FIGS. 2A-2B show one arrangement for cleaning a flat screen according to the prior art.

[0019] FIG. 3A shows a front view of another arrangement for cleaning a flat screen according to the prior art.

[0020] FIGS. 3B-3C shows the arrangement of FIG. 3A using side and perspective views relative to a flat screen.

[0021] FIG. 4A schematically shows a plan view of a flat screen in an enclosure.

[0022] FIG. 4B shows a vertical orientation of the flat screen with an airburst distribution system of the present disclosure.

[0023] FIG. 4C shows a horizontal orientation of the flat screen with the airburst distribution system.

[0024] FIGS. 5A-5B show front and back perspective views of the airburst distribution system.

[0025] FIGS. 6A-6D show front, end, and top views of the airburst distribution system.

[0026] FIG. 7 shows an isolated front view of the manifold and pipes for the airburst distribution system.

[0027] FIGS. 8A-8B show end and front views of a longitudinal director.

[0028] FIGS. 8C and 8D show end views of different shaped longitudinal directors relative to a pipe.

[0029] FIGS. 9A-9C diagrammatically show progression of an airburst from a distribution pipe and director of the disclosed system.

DETAILED DESCRIPTION

[0030] As noted previously, water intakes, diversion panels, and other applications may have flat screens. FIG. 4A schematically shows a plan view of a flat screen **80** in an enclosure **85**. The flat screen **80** is composed of parallel wires attached to rods arranged perpendicular thereto. The wires can be profiled wire or any other suitable type of wire for a screen, filter, diversion panel, or the like. The enclosure **85** is only schematically depicted in the Figures for illustration purposes and may have one or more outlets **87** as shown. Depending on the implementation, the enclosure **85** can be any suitable module, component, pipe, conduit, outlet, inlet, or the like for a water intake, filtration, diversion, or other type of system.

[0031] As shown in FIG. 4B, the flat screen **80** can be situated vertically in an open end of the enclosure **85**. Alternatively, the flat screen **80** can be situated horizontal as shown in FIG. 4C, although any orientation may be used. Either way, the flat screen **80** may collect debris carried by water passing through the screen **80** into the enclosure **85**.

[0032] To clear the debris periodically, an airburst distribution system **100** of the present disclosure disposes parallel to the screen **80**. This system **100** couples to components of an hydroburst system, such as described previously with reference to FIG. 1. As noted above, such a hydroburst system has a tank, a control panel, rapid actuating air valves, connecting piping, and an air compressor for providing a quick airburst of compressed air. When activated manually or automatically on a periodic basis, the airburst from the hydroburst system

enters the airburst distribution system **100**, which disperses the air in the enclosure **85** relative to the panel screen **80** to dislodge any collected debris.

[0033] One advantage of the airburst distribution system **100** is its modular nature and ability to fit a particular implementation. The system **100** can be constructed separately from the components of the enclosure **85** and the flat screen **80**. The pre-assembled system **100** can then be conveniently incorporated into the enclosure **85** adjacent the screen **80** to meet the debris cleaning needs of the installation.

[0034] The airburst distribution system **100** is depicted in FIGS. 4A-4B with a relative size compared to the flat screen **80** and the enclosure **85**. The depicted sizes are for illustrative purposes. In general, the relative size between the airburst distribution system **100**, the flat screen **80**, and the enclosure **85** depends on the implementation and details such as desired flow rates, need for debris cleaning, amount of compressed air that can be produced in an airburst, and other practical factors. Moreover, one or more airburst distribution systems **100** may be situated adjacent a flat screen **80**, and all or just a portion of the screen **80** may have an airburst distribution systems **100** adjacent to it.

[0035] Turning now to particular details shown in FIGS. 5A-5B, 6A-6D, and 7, the airburst distribution system **100** has a manifold **110**, distribution pipes **120**, directors **130**, braces **140/142**, and brackets **150**. The manifold **110** has an inlet **114** that connects to components of the hydroburst system providing the supply of compressed air. Along its length, the manifold **110** can have orifices **112** for dispersing air to the surroundings. The orifices **112** are arranged in the manifold **110** to uniformly disperse the air.

[0036] Extending parallel to one another off the manifold **110**, the distribution pipes **120** convey air from the manifold **110** so the air can be dispersed out of orifices **122** in the pipes **120**. These distribution pipes **120** run parallel to the surface of the flat screen (**80**). The number of pipes **120**, their diameters (or flow areas), the number of orifices **122**, and other considerations depend on the particular implementation.

[0037] An arrangement of directors **130** directs the force of the release and burst of air from the pipes **120** toward the surface of the flat screen (**80**). In turn, the airburst forces debris away and scours the screen's surface. The directors **130** run longitudinally behind each of these distribution pipes **120**, essentially separating or isolating the parallel pipes **120** from one another. The directors **130** may run the entire length of the pipes **120** or more than one director **130** can be set end to end along the length of a given pipe **120** to complete its entire distance.

[0038] To support the directors **130**, the system **100** affixes the various directors **130** together in a lattice. Fasteners **145**, which can be U-bolts or the like, affix the directors **130** to the distribution pipes **120** at various points along the lengths of the pipes **120**. Additionally, the braces **140/142**, which are laterally arranged fasteners, affix to the fronts and backs of the directors **130** and interconnect them to one another in the lattice. As shown, these braces **140/142** can be thin metal bars affixed by bolts or other fasteners to the directors **130**.

[0039] Finally, to support the manifold **110**, pipes **120**, and directors **130**, a number of support brackets **150** affix to the backs of the directors **130**. These brackets **150** include legs **152** that attach across the backs of the parallel directors **130**. Ends of the legs **152** have feet **154/156** to affix the brackets

150 to any other component, such as an enclosure, pipe, concrete wall, other bracket, or the like, as shown in FIGS. 4B-4C, for example.

[0040] As best shown in the isolated front view of FIG. 7, the manifold **110** includes a reducer **116** disposed between a proximal end **111** (connected to the inlet **114** and two of the pipes **120a**) and a distal end **113** (connected to the other two pipes **120b**). The diameter (or flow area) of the manifold **110** changes at the reducer **116**. For example, the mandrel's larger portion **111** may have a diameter of about 3-in., while the mandrel's smaller portion **113** may have a diameter of about 2-in.

[0041] The (two lower) pipes **120a** have their proximal ends **121a** connected to the mandrel's larger diameter portion **111** and have a larger diameter (or flow area) compared to the (two upper) other pipes **120b**, which have their proximal ends **121b** connected to the mandrel's smaller diameter portion **113**. For example, the (two lower) pipes **120a** may have an initial diameter at their proximal ends **121a** of about 2-in., while the (two upper) pipes **120b** may have an initial diameter at their proximal ends **121b** of about 1.5-in.

[0042] The pipes **120** also include reducers **126** at about three-fourths of the length of the pipes **120** in which the diameter (or flow area) of the pipes **120** decreases toward the pipes' distal ends. For example, the (two lower) pipes **120a** may reduce from the 2-in. diameter at their proximal ends **121a** to about 1.5-in. diameter at their distal ends **123a**. The (two upper) pipes **120b** may reduce from the 1.5-in. diameter at their proximal ends **121b** to about 1.25-in. diameter at their distal ends **123b**. Moreover, the distal ends **123a-b** are shorter in length than the proximal ends **121 a-b**, further reducing flow area. The reducers **116/126** and different diameter pipes **120a-b** are intended to control the airflow exiting the orifices **112/122** down the length of the manifold **110** and pipes **120** and maintain suitable pressure for the airburst.

[0043] As best shown in FIGS. 5A-5B, separate directors **130'** may be used due to the reduced diameter at the distal ends of the pipes **120**. These separate directors **130'** attach to the distal ends of the pipes **120** with fasteners **145** as before, but suited to accommodate the smaller diameter. Rather than using the separate directors **130'**, the directors **130** can extend the entire length of the pipes **120**, and spacers can be used between the pipes' distal ends and the directors **130**. Alternatively, the directors **130** extending the entire length of the pipes **120** can define a step or bend to accommodate the reduced diameter at the pipes' distal ends.

[0044] Preferably, gaps are present between edges of the directors **130**, permitting water flow between the directors **130**. Furthermore, each of the longitudinal directors **130** defines a longitudinal channel **131** behind the pipes **120**. As shown in FIGS. 8A and 8B, the director's longitudinal channel **131** is formed by a backwall **132** and opposing sidewalls **134** that angle inward toward the backwall **132**. Edge faces **136** can be provided on the upper and lower edges along the length of the director **130** for affixing the braces (**140**) thereto. The backwall **132** rests behind the distribution pipe (**120**), which has its orifices (**122**) facing away from the director **130**.

[0045] The overall length of the director **130** depends on the implementation. For example, the longer sectioned directors **130** can be about 71-in. long, while the shorter section directors **130'** can be about 37.75-in. long. In general, the width of the directors **130** can be about 11-inches, while the depth can be about 2.88-inches. Compared to the larger pipes **120**, which can have a diameter of about 1.5 to about 2-in., the depth of

the director's channels **131** is at least less than or equal to about twice the pipe's diameter. Actual dimensions depend on the implementation and the size of distribution pipes **120**, among other factors. Additionally, the shape and/or angle of the deflectors **130** can be altered. For example, rounded surfaces may also be employed in a similar fashion to the angled flat surfaces shown. Moreover, the cross-sectional shape of the deflector **130** need not be symmetrical as shown in FIG. 8A. Instead, the shape can be asymmetrical as with the deflectors **130'** and **130''** in FIG. 8C, shown relative to the cross-section of a pipe **120**.

[0046] Because the disclosed airburst distribution system **100** must deliver an airburst to a flat screen disposed parallel thereto, the system **100** preferably delivers the airburst effectively to the adjacent screen. Effective delivery is at least partially achieved by the directors **130** of the disclosed system **100**. In particular, FIGS. 9A-9C diagrammatically show progression of an airburst from a distribution pipe **120** and director **130** of the disclosed system.

[0047] When the airburst is initiated, the air leaves the forward facing orifices **122** in the distribution pipe **120** as shown in FIG. 9A. The distribution pipe **120** distributes the air in a generally radial direction from the orifices **122** in the pipe **120**. As the leaving air expands from the orifice **122**, it tends to travel outward in all directions from the orifice **122** and even tends to travel back behind the pipe **120** as shown in FIG. 9B.

[0048] However, the director **130** with its backwall **132** and inward opposing sidewalls **134** tends to focus or collect the airburst in a forward direction of the distribution pipe **120** as shown in FIGS. 9B-9C. This collects the airburst in a direction more suited for interacting with an adjacent flat screen at which the pipe **120** and director **130** face. In this way, the director **130** forces the air/water from the airburst in the direction best suited to clean the surface of a flat screen.

[0049] The foregoing description of preferred and other embodiments is not intended to limit or restrict the scope or applicability of the inventive concepts conceived of by the Applicants. Although referred to as providing an airburst, the disclosed system **100** can expel a burst of any suitable fluid (e.g., water, air, etc.) from the orifices **112/122** in the manifold **110** and pipes **120** to clear debris from an adjacent screen. Although the system **100** is described for use with a flat screen, the screen need not be strictly flat and may actually be curved either longitudinally, laterally, or both. In exchange for disclosing the inventive concepts contained herein, the Applicants desire all patent rights afforded by the appended claims. Therefore, it is intended that the appended claims include all modifications and alterations to the full extent that they come within the scope of the following claims or the equivalents thereof

What is claimed is:

1. A debris cleaning apparatus for a screen, the apparatus comprising:

a plurality of pipes disposed parallel to one another and in fluid communication with a fluid inlet of the apparatus, each pipe having a first side adjacent the screen and having a second side opposite the first side, each pipe having a plurality of orifices in the first side for expelling fluid; and

a plurality of directors disposed parallel to one another and affixed to each other in a lattice, each director having one of the pipes affixed therein and having a channel in

which the pipe disposes, each director directing fluid expelled from the orifices in the pipe toward the adjacent screen.

2. The apparatus of claim 1, further comprising a manifold connecting the pipes in fluid communication with the fluid inlet of the apparatus.

3. The apparatus of claim 2, wherein the manifold defines a plurality of orifices in a side facing the screen.

4. The apparatus of claim 2, wherein the pipes have proximal and distal ends, the proximal ends in fluid communication with the manifold.

5. The apparatus of claim 4, wherein each of the pipes defines a first flow area at the proximal end and a second flow area at the distal end, the first flow area being greater than the second flow area.

6. The apparatus of claim 4, wherein the manifold defines at least two flow areas, a first of the flow areas communicating the inlet of the apparatus to a second of the flow areas, the first flow area being greater than the second flow area.

7. The apparatus of claim 6, wherein:

the proximal ends of one or more first of the pipes are in fluid communication with the first flow area of the manifold,

the proximal ends of one or more second of the pipes are in fluid communication with the second flow area of the manifold, and

wherein the one or more first pipes have a larger flow area than a smaller flow area of the one or more second pipes.

8. The apparatus of claim 1, wherein the channels each define a depth that is at least less than or equal to two times a diameter of the pipe disposed therein.

9. The apparatus of claim 1, wherein the lattice comprises a plurality of fasteners laterally interconnecting the directors to one another.

10. The apparatus of claim 9, wherein the fasteners include first braces affixed to front edges of the directors.

11. The apparatus of claim 9, wherein the fasteners include second braces affixed to backs of the directors.

12. The apparatus of claim 1, further comprising a plurality of brackets affixed to backs of the directors.

13. The apparatus of claim 1, wherein the directors each comprises a plurality of walls defining the channel, the walls including a backwall and two opposing sidewalls, the backwall disposed adjacent the second side of the pipe, the two opposing sidewalls angled inward toward the backwall.

14. The apparatus of claim 13, wherein fasteners affix the pipes to the backwalls of the directors.

15. The apparatus of claim 1, further comprising a tank holding compressed air in fluid communication with the inlet.

16. The apparatus of claim 15, further comprising a compressor in fluid communication with the tank and charging the tank with the compressed air.

17. The apparatus of claim 15, further comprising one or more valves in fluid communication between the tank and the pipes and controlling release of the compressed air from the tank to the inlet.

18. A debris cleaning apparatus for a screen, the apparatus comprising:

a manifold having a first flow area in fluid communication with a second flow area, the first flow area being greater than the second flow area and being in fluid communication with an inlet of the apparatus;

a plurality of pipes disposed parallel to one another and in fluid communication with the manifold, each pipe having a first side adjacent the screen and having a second side opposite the first side, each pipe having a plurality of orifices in the first side, at least one first of the pipes in fluid communication with the first flow area of the manifold, at least one second of the pipes in fluid communication with the second flow area, the at least one first pipe defining a larger flow area than a smaller flow area of the at least one second pipe; and

a plurality of directors disposed parallel to one another and affixed to each other in a lattice, each director having one of the pipes affixed therein and having a channel in which the pipe disposes, each director directing an airburst from the orifices in the disposed pipe toward the adjacent screen.

19. The apparatus of claim 18, wherein the larger flow area of the at least one first pipe includes third and fourth flow areas, the third flow area in fluid communication between the manifold and the fourth flow area and being greater than the fourth flow area.

20. A screen intake system, comprising:

a body having an open end and defining a chamber;

a screen disposed at the open end of the body;

a plurality of pipes disposed parallel to one another in the chamber and in fluid communication with an inlet of the system, each pipe having a first side adjacent the screen and having a second side opposite the first side, each pipe having a plurality of orifices in the first side; and

a plurality of directors disposed parallel to one another in the chamber and affixed to each other in a lattice, each director having one of the pipes affixed therein and having a channel in which the pipe disposes, each director directing an airburst from the orifices in the disposed pipe toward the adjacent screen.

* * * * *