



US 20140047804A1

(19) **United States**
(12) **Patent Application Publication**
Evans et al.

(10) **Pub. No.: US 2014/0047804 A1**
(43) **Pub. Date: Feb. 20, 2014**

(54) **DIRECT TO CONTAINER SYSTEM WITH ON-LINE WEIGHT CONTROL AND ASSOCIATED METHOD**

Publication Classification

(71) Applicant: **ALTRIA CLIENT SERVICES INC., RICHMOND, VA (US)**

(51) **Int. Cl.**
B65B 5/10 (2006.01)
(52) **U.S. Cl.**
CPC **B65B 5/101** (2013.01)
USPC **53/473; 53/77**

(72) Inventors: **James D. Evans**, Chesterfield, VA (US); **Herbert Cary Longest**, Midlothian, VA (US); **Tamika S. Murrell**, Richmond, VA (US); **Robert V. Powell, JR.**, Richmond, VA (US); **Jeremy Straight**, Midlothian, VA (US); **Jarrod Chalkley**, Mechanicsville, VA (US)

(57) **ABSTRACT**

(73) Assignee: **ALTRIA CLIENT SERVICES INC., RICHMOND, VA (US)**

Systems and methods for manufacturing and inserting a pre-determined number of material-filled pouches into containers are disclosed. A system includes a pouch providing system comprising a plurality of lanes, wherein each one of the plurality of lanes includes a pouch making machine and a hold-back structure. The system also includes a conveyor system structured and arranged to move a plurality of containers into alignment with the plurality of lanes. The system further includes a controller structured and arranged to control the hold-back structure in each one of the plurality of lanes such that the pre-determined pouches are inserted into the plurality of containers when the plurality of containers are aligned with the plurality of lanes.

(21) Appl. No.: **13/967,181**

(22) Filed: **Aug. 14, 2013**

Related U.S. Application Data

(60) Provisional application No. 61/683,034, filed on Aug. 14, 2012.

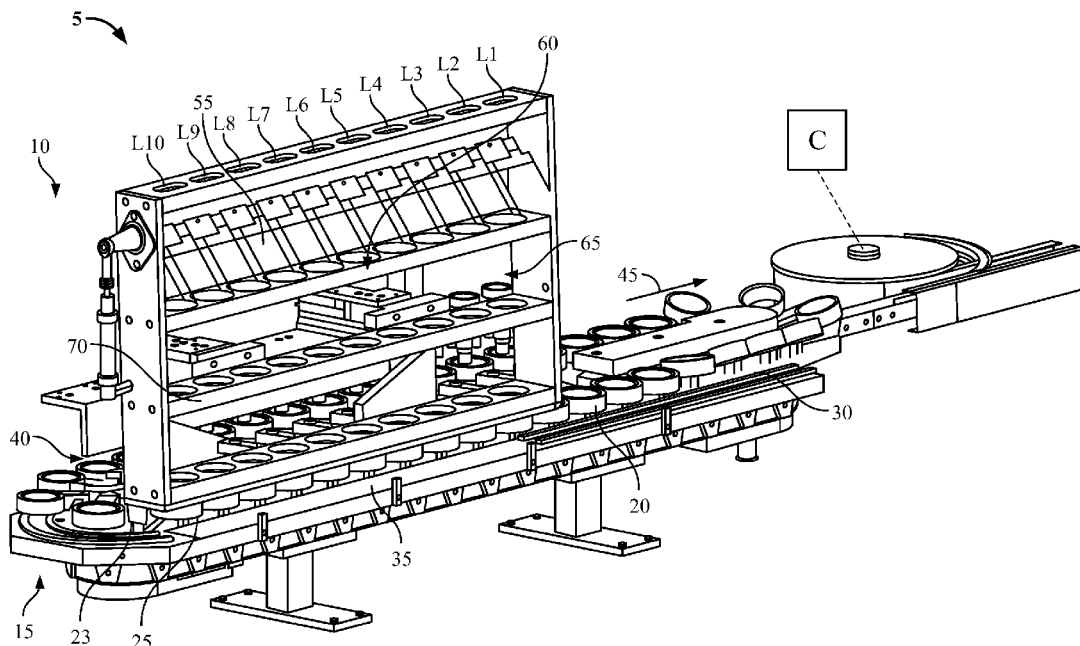

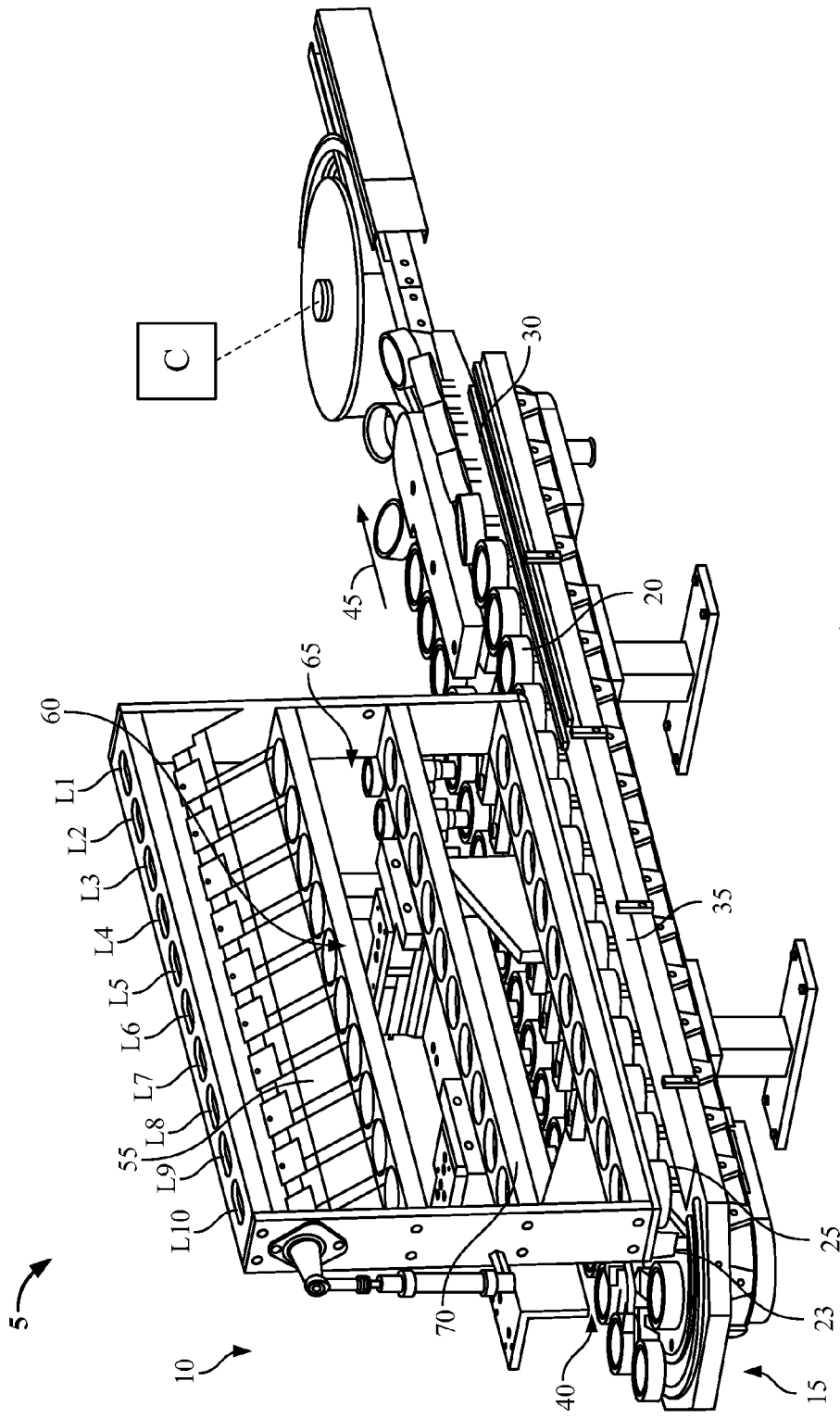

FIG. 1A

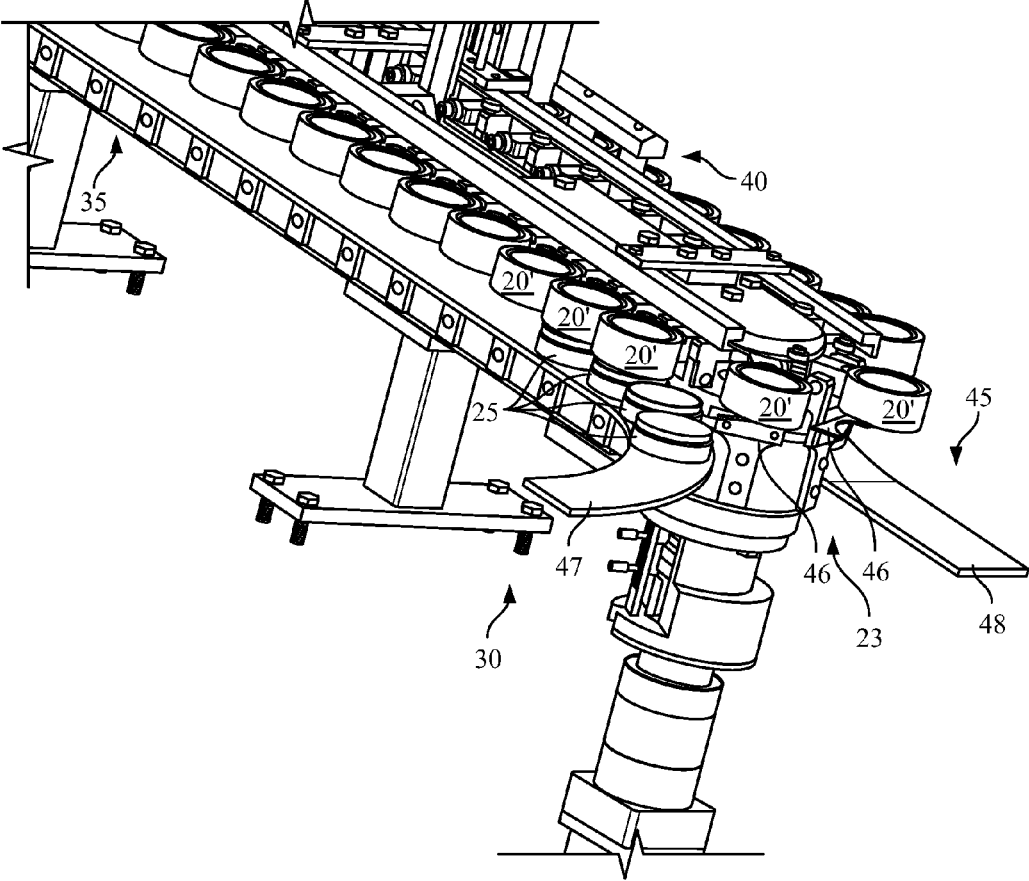

FIG. 1B

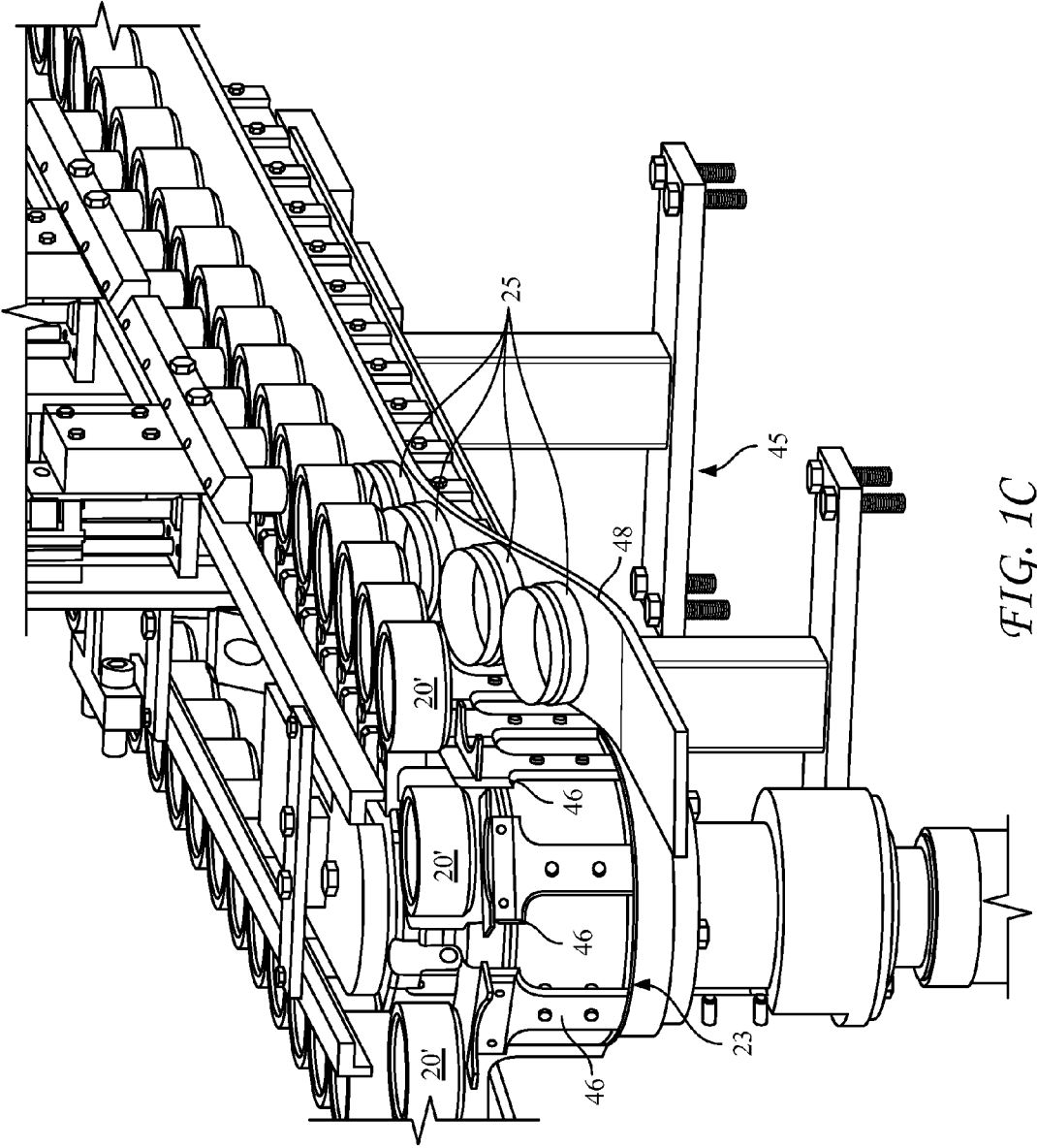

FIG. 1C

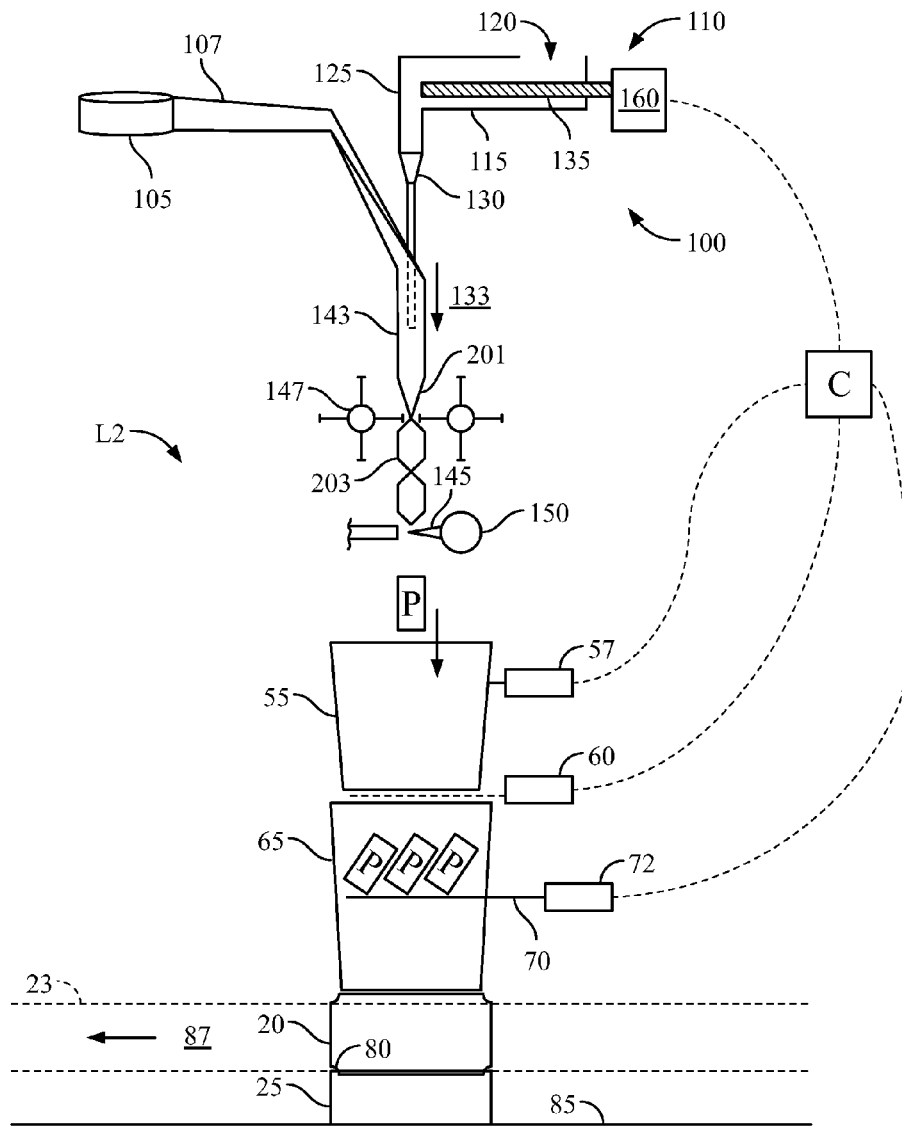

FIG. 2

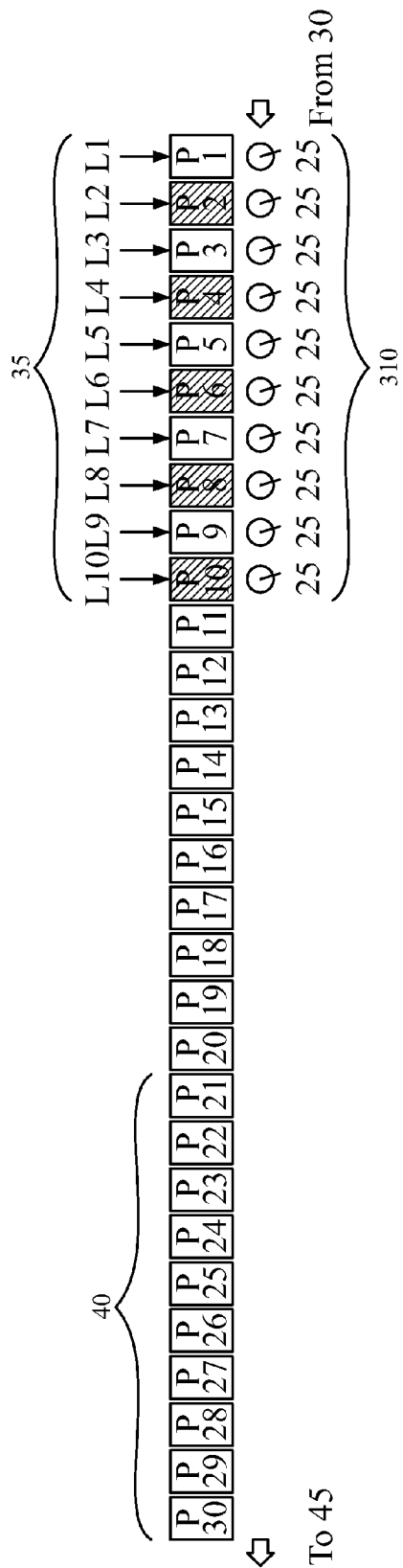

FIG. 3

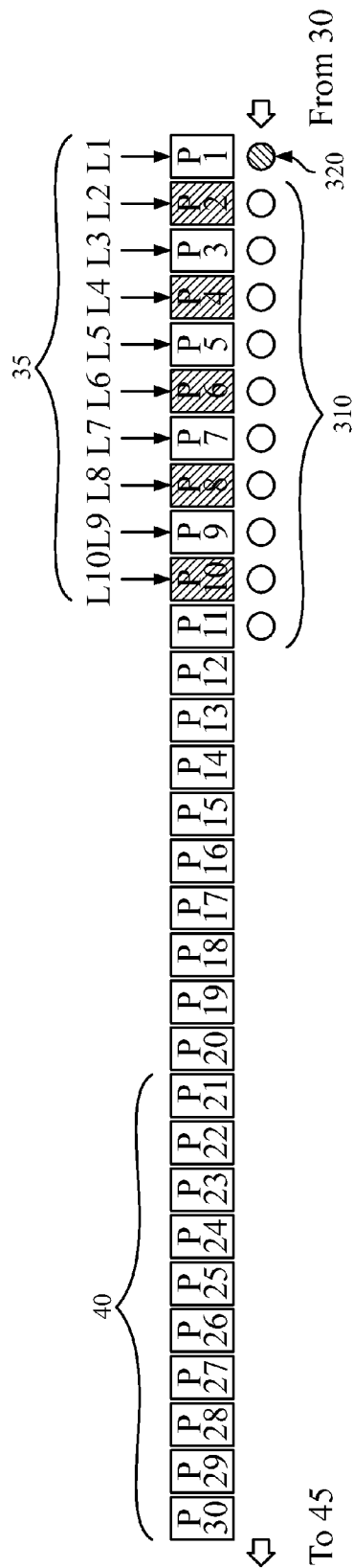

FIG. 4

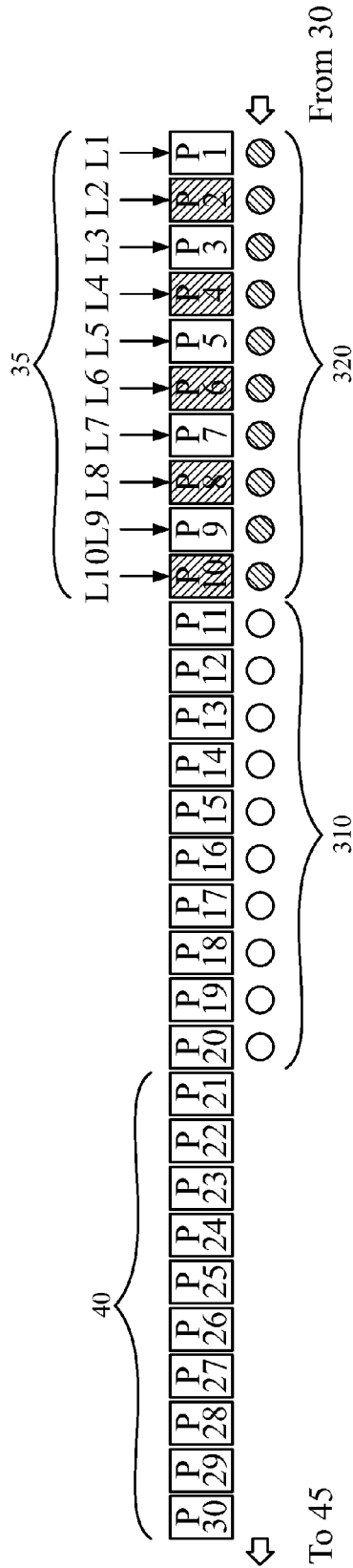

FIG. 5

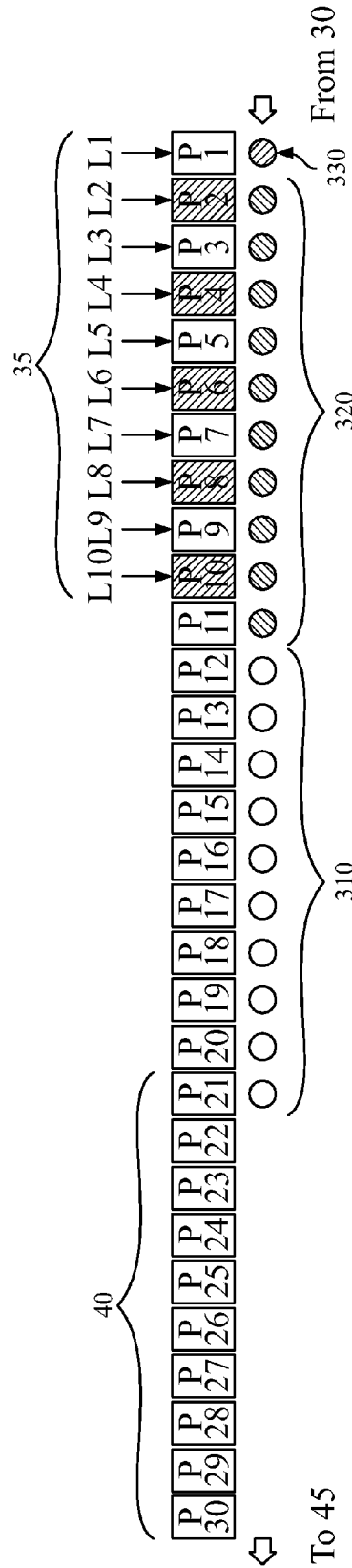

FIG. 6

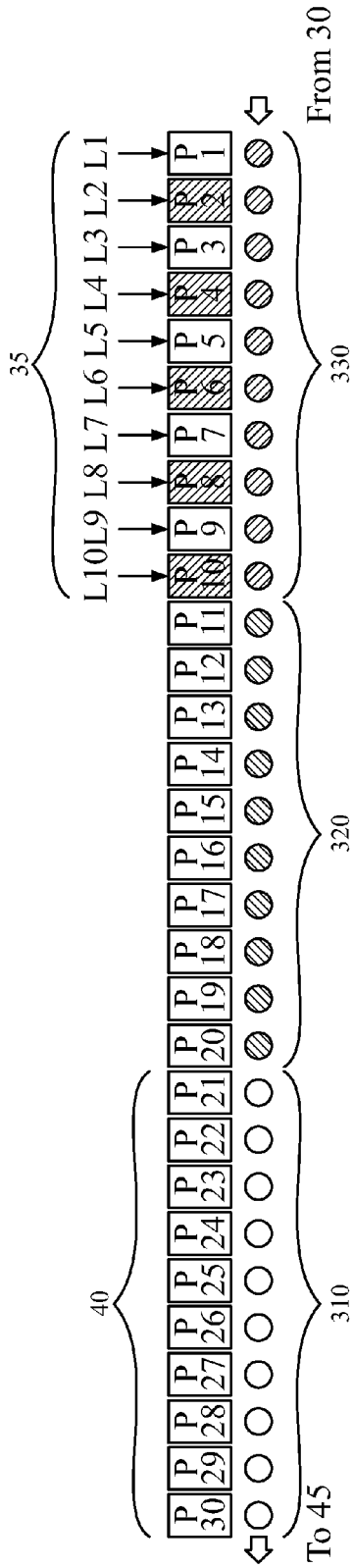

FIG. 7

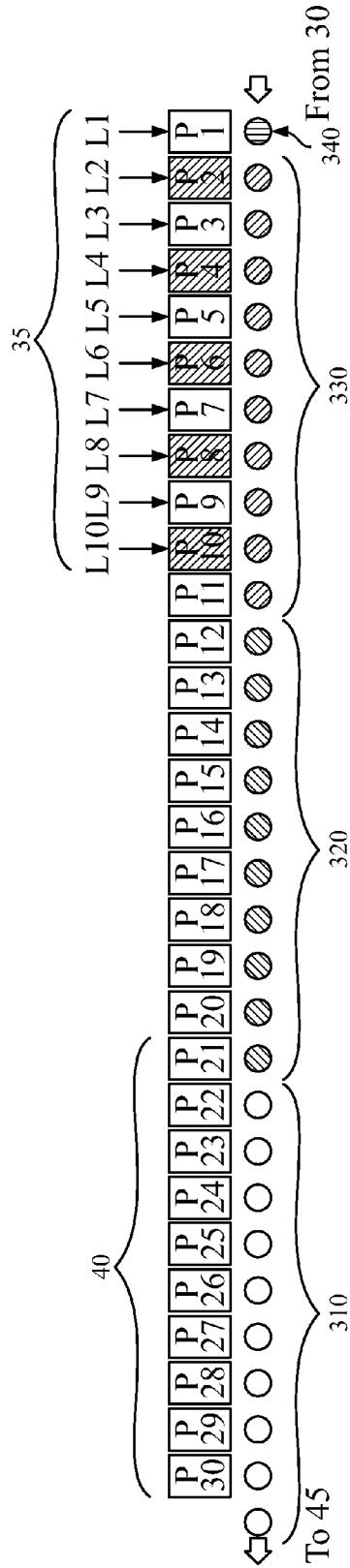

FIG. 8

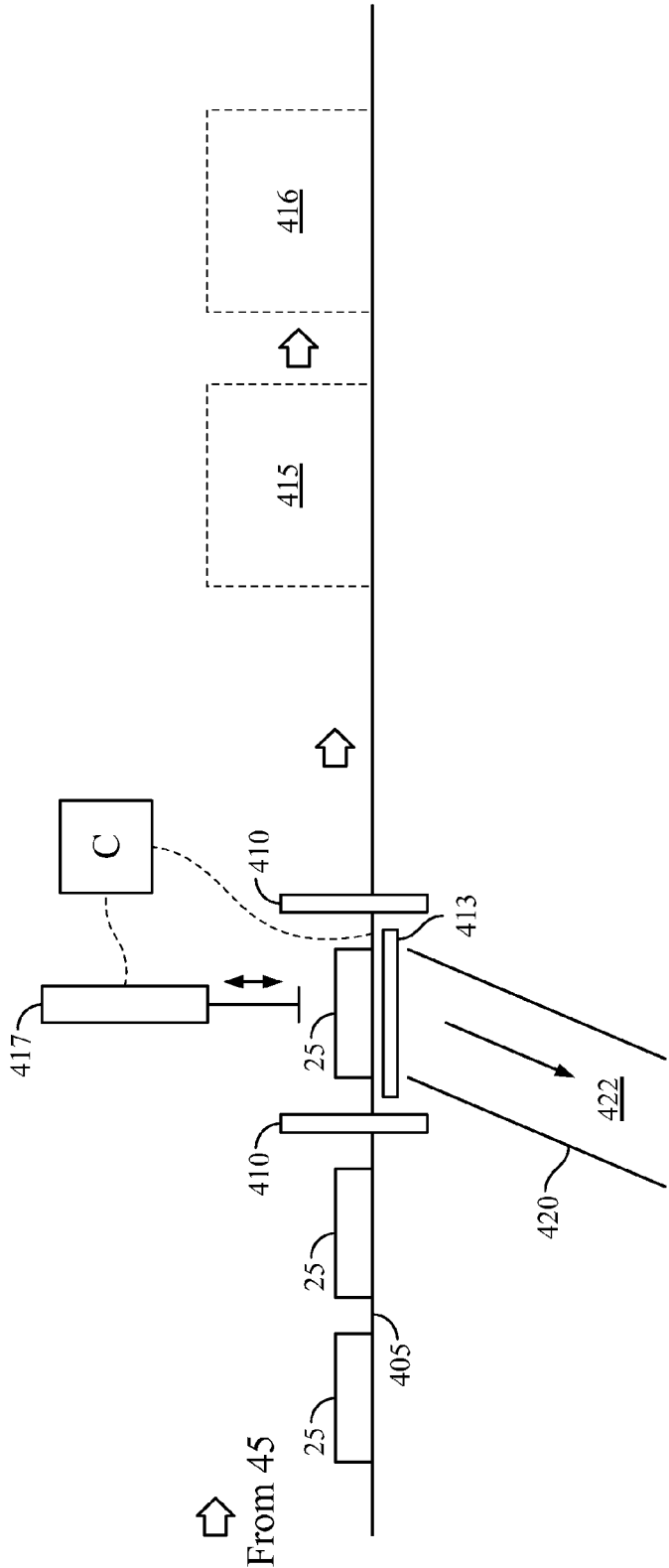

FIG. 9

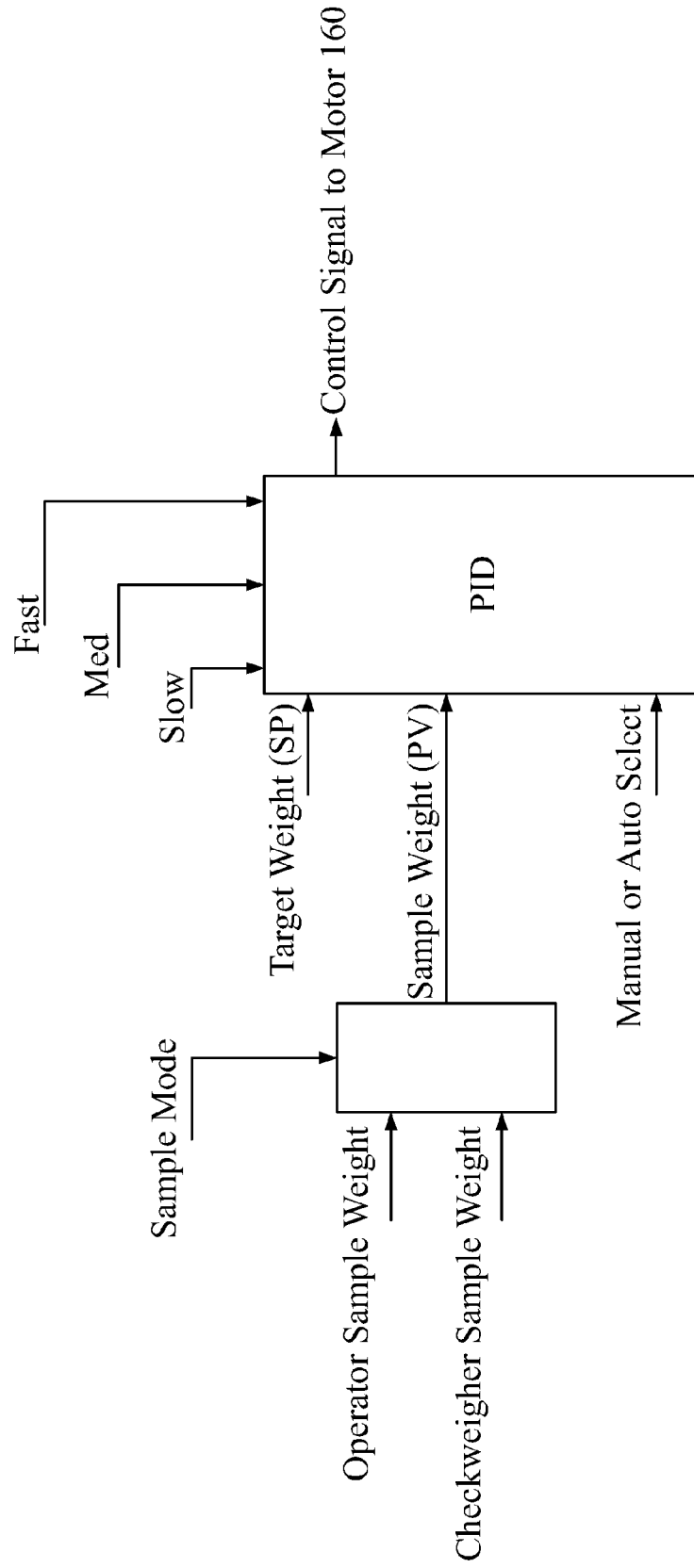
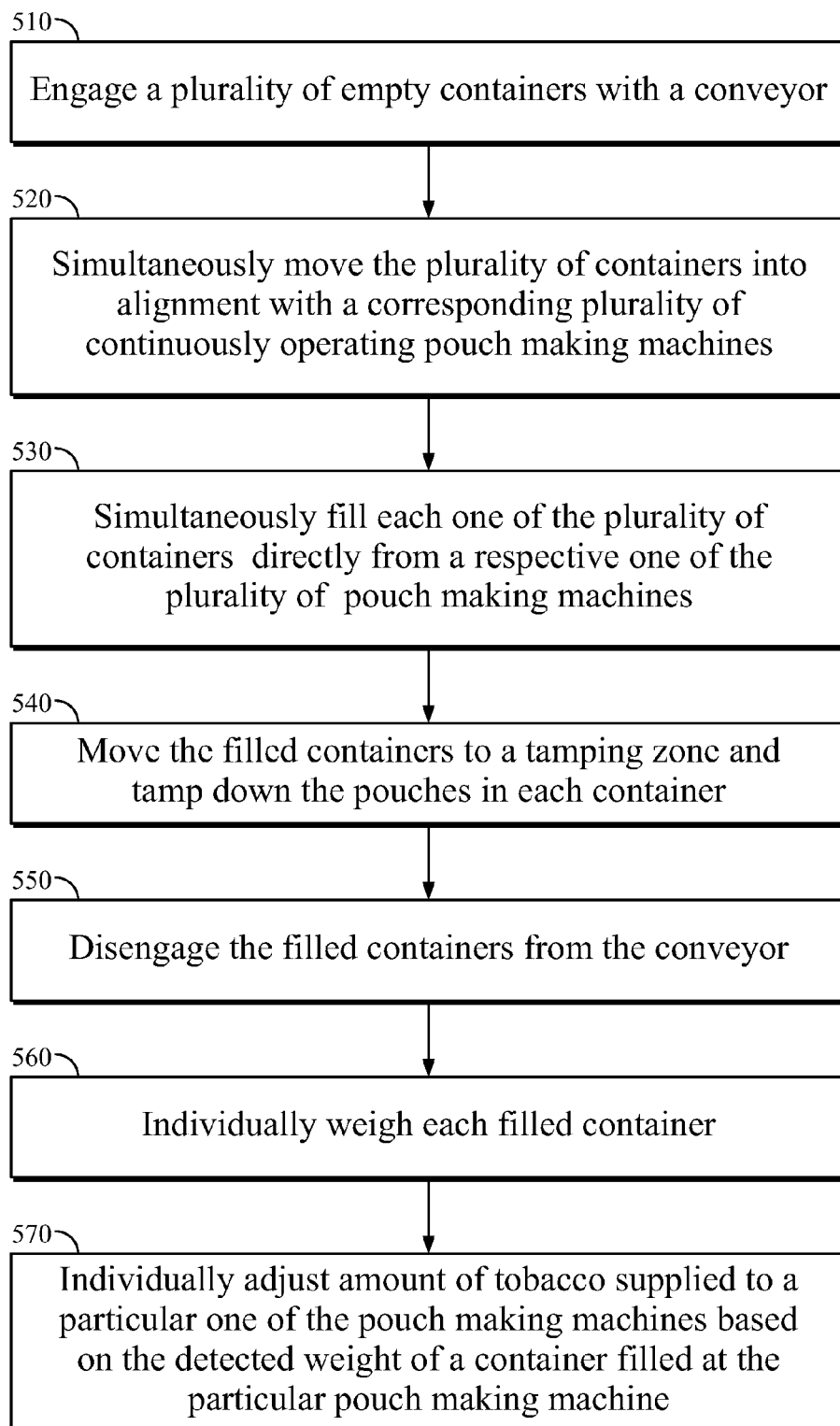

FIG. 10

*FIG. 11*

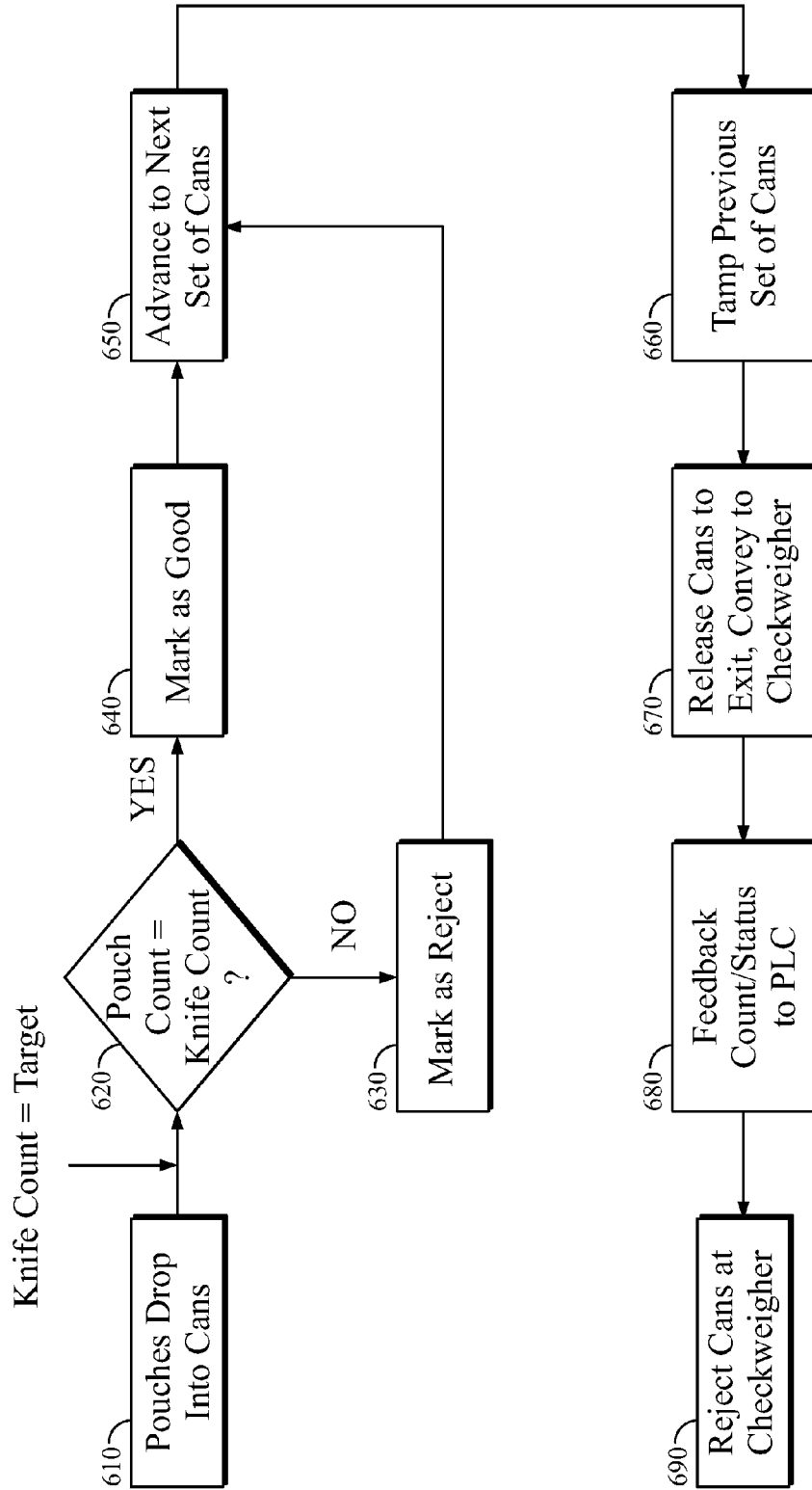

FIG. 12

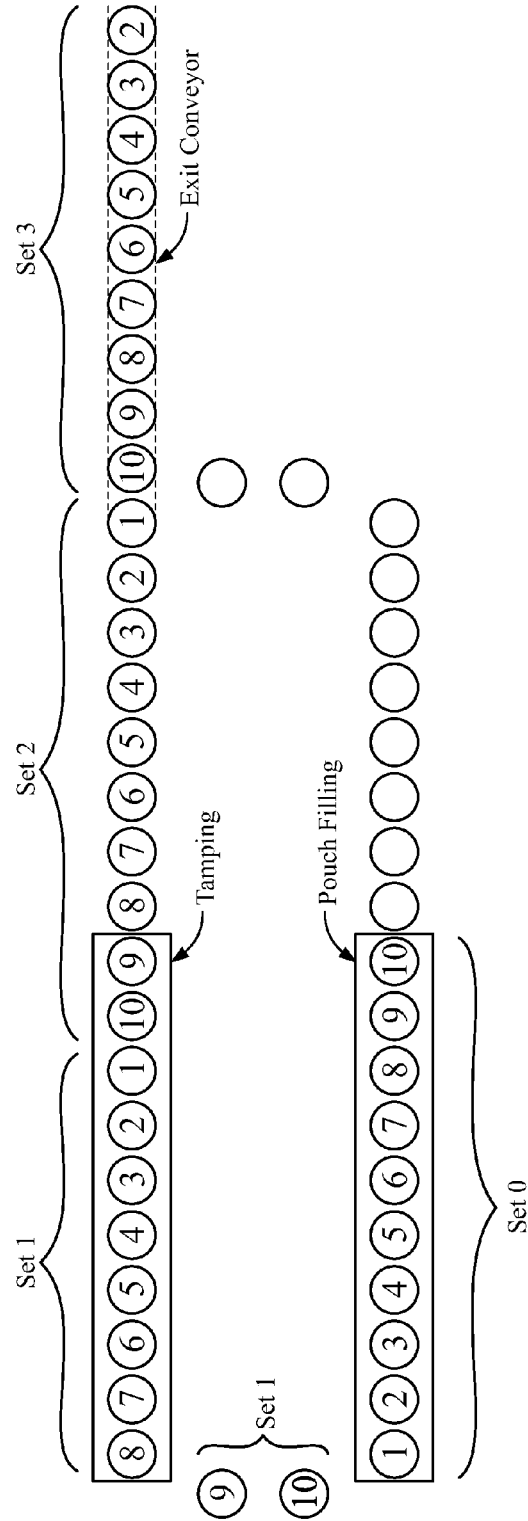

FIG. 13

**DIRECT TO CONTAINER SYSTEM WITH
ON-LINE WEIGHT CONTROL AND
ASSOCIATED METHOD**

RELATED APPLICATION

[0001] This application claims the benefit of U.S. Provisional Application Ser. No. 61/683,034, filed on Aug. 14, 2012, the contents of which are hereby incorporated by reference in their entirety.

FIELD

[0002] This disclosure relates generally to systems and methods for filling containers with units of smokeless tobacco and, more particularly, to manufacturing and inserting pouches of smokeless tobacco into containers in a continuous operation with on-line weight control.

SUMMARY

[0003] Various forms of smokeless tobacco, including pouched smokeless tobacco (snus) are provided to the consumer in a lidded cylindrical container (e.g., a can) composed of metal, paperboard or plastic. Pouched snus may comprise an amount of tobacco encased in a paper case.

[0004] Heretofore, a large number of pouches were manufactured by plural pouch-making lanes and/or machines (e.g., pouchers) whose outputs were deposited together (e.g., comingled) in an intermediate holding bin. Such comingling can confound quality control. For example, with comingling, it may become impossible to determine which one of many pouchers caused a particular can to be over or under weight.

[0005] In accordance with aspects disclosed herein, there is a system and method for filling cans with pouches directly from a pouch-making machine, weighing the filled cans, and selectively adjusting the pouch-making machine based on the weighing. In embodiments, the system comprises a pouch-making machine having plural vertically-oriented lanes, each of which individually manufactures pouches filled with smokeless tobacco and inserts the pouches into a container (e.g., can) that may be sold to a consumer. Each lane may comprise an individual poucher and a transfer structure that guides completed pouches into a can positioned in the lane. The system may comprise a conveyor that controllably moves cans into alignment with the transfer structures of the plural lanes where each can is individually filled with pouches directly from a respective one of the lanes. In embodiments, the conveyor moves the filled cans to a tamping station and simultaneously moves a new set of empty cans into alignment with the transfer structures of the plural lanes. The system may incorporate a controllable hold-back structure in each of the transfer structures so that pouches may be continuously made even during movement of the cans by the conveyor. The system may also incorporate one or more sensors in each lane to accurately count the number of pouches inserted into each can.

[0006] In accordance with additional aspects disclosed herein, each can is weighed individually after being filled with pouches. In embodiments, the system is structured and arranged to associate each can with a respective one of the lanes, and to maintain this association through the can-weighing process. When a particular can is determined to be over or under weight via the can-weighing process, the association between the can and a particular lane may be used to adjust at least one manufacturing parameter of the lane. For example,

the rate of tobacco being supplied to the poucher of a particular lane may be selectively increased or decreased based on the weighing of a can that was filled at that particular lane.

[0007] According to a first aspect, there is a system for manufacturing and inserting tobacco-filled pouches into containers. The system includes a pouch providing system comprising a plurality of lanes, wherein each one of the plurality of lanes comprises a pouch making machine and a hold-back structure. The system also includes a conveyor system structured and arranged to move a plurality of containers into alignment with the plurality of lanes. The system further includes a controller structured and arranged to control the hold-back structure in each one of the plurality of lanes such that pouches are inserted into the plurality of containers when the plurality of containers are aligned with the plurality of lanes.

[0008] According to another aspect, there is a method for manufacturing and inserting tobacco-filled pouches into containers. The method includes: engaging a plurality of containers with a conveyor system; simultaneously moving the plurality of containers into alignment with a corresponding plurality of pouch making machines; inserting pouches directly from respective ones of the plurality of pouch making machines into respective ones of the plurality of containers; individually weighing each one of the plurality of containers after the inserting; and adjusting a rate of tobacco supplied to a respective one of the plurality of pouch making machines based on the weighing.

BRIEF DESCRIPTION OF THE DRAWINGS

[0009] Various aspects are further described in the detailed description which follows, in reference to the noted plurality of drawings by way of non-limiting examples of embodiments, in which like reference numerals represent similar parts throughout the several views of the drawings.

[0010] FIG. 1A shows an exemplary system for manufacturing and inserting smokeless tobacco pouches into containers in accordance herewith;

[0011] FIGS. 1B and 10 show an alternative embodiment of aspects of the system;

[0012] FIG. 2 shows an exemplary lane of the system of FIG. 1A;

[0013] FIGS. 3-8 illustrate an exemplary operation of the system of FIG. 1A;

[0014] FIG. 9 shows an exemplary on-line weighing system in accordance herewith;

[0015] FIG. 10 depicts a block diagram of a control scheme in accordance herewith;

[0016] FIG. 11 shows a flow diagram of a method in accordance herewith;

[0017] FIG. 12 presents a sequencing diagram for an embodiment of a system and method in accordance herewith; and

[0018] FIG. 13 depicts how the containers transition to different stations on the conveyor from machine startup.

DETAILED DESCRIPTION

[0019] Various aspects will now be described with reference to specific forms selected for purposes of illustration. It will be appreciated that the spirit and scope of the apparatus, system and methods disclosed herein are not limited to the selected forms. Moreover, it is to be noted that the figures provided herein are not drawn to any particular proportion or

scale, and that many variations can be made to the illustrated forms. Reference is now made to FIGS. 1-11, wherein like numerals are used to designate like elements throughout.

[0020] Each of the following terms written in singular grammatical form: “a,” “an,” and “the,” as used herein, may also refer to, and encompass, a plurality of the stated entity or object, unless otherwise specifically defined or stated herein, or, unless the context clearly dictates otherwise. For example, the phrases “a device,” “an assembly,” “a mechanism,” “a component,” and “an element,” as used herein, may also refer to, and encompass, a plurality of devices, a plurality of assemblies, a plurality of mechanisms, a plurality of components, and a plurality of elements, respectively.

[0021] Each of the following terms: “includes,” “including,” “has,” “having,” “comprises,” and “comprising,” and their linguistic or grammatical variants, derivatives, and/or conjugates, as used herein, means “including, but not limited to.”

[0022] Throughout the illustrative description, the examples, and the appended claims, a numerical value of a parameter, feature, object, or dimension, may be stated or described in terms of a numerical range format.

[0023] It is to be fully understood that the stated numerical range format is provided for illustrating implementation of the forms disclosed herein, and is not to be understood or construed as inflexibly limiting the scope of the forms disclosed herein.

[0024] Moreover, for stating or describing a numerical range, the phrase “in a range of between about a first numerical value and about a second numerical value,” is considered equivalent to, and means the same as, the phrase “in a range of from about a first numerical value to about a second numerical value,” and, thus, the two equivalently meaning phrases may be used interchangeably.

[0025] It is to be understood that the various forms disclosed herein are not limited in their application to the details of the order or sequence, and number, of steps or procedures, and sub-steps or sub-procedures, of operation or implementation of forms of the method or to the details of type, composition, construction, arrangement, order and number of the system, system sub-units, devices, assemblies, sub-assemblies, mechanisms, structures, components, elements, and configurations, and, peripheral equipment, utilities, accessories, and materials of forms of the system, set forth in the following illustrative description, accompanying drawings, and examples, unless otherwise specifically stated herein. The apparatus, systems and methods disclosed herein can be practiced or implemented according to various other alternative forms and in various other alternative ways.

[0026] It is also to be understood that all technical and scientific words, terms, and/or phrases, used herein throughout the present disclosure have either the identical or similar meaning as commonly understood by one of ordinary skill in the art, unless otherwise specifically defined or stated herein. Phraseology, terminology, and, notation, employed herein throughout the present disclosure are for the purpose of description and should not be regarded as limiting.

[0027] This disclosure relates generally to systems and methods for filling containers with units of smokeless tobacco and, more particularly, to manufacturing and inserting pouches of smokeless tobacco into containers in a continuous operation with on-line weight control. According to aspects disclosed herein, a system includes plural pouch making machines that operate continuously and in parallel.

[0028] A conveyor system may be structured and arranged to simultaneously move plural empty containers into alignment with the plural pouch making machines, such that the respective containers are simultaneously filled with pouches directly from respective ones of the pouch making machines. The position of each container may be tracked throughout the entire system, and each container may be associated with the particular one of the pouch making machines from which it was filled. Each container may be weighed after being filled, and at least one operational parameter of the pouch making machine associated with the weighed container may be adjusted based on the weight of the container independent of the other pouch making machines.

[0029] FIG. 1A shows an exemplary system 5 for manufacturing and inserting pouches into containers in accordance herewith. In embodiments, the system 5 includes a direct-to-container pouch providing system 10 and a conveyor system 15. The pouch providing system 10 controls the movement of individual pouches into a plurality of containers from a plurality of pouch making lanes or machines. The conveyor system 15 moves the containers to positions in alignment with the lanes of the pouch providing system 10 such that the manufactured pouches are inserted from the pouch providing system 10 directly into the container without comingling of the pouches. As described herein, the pouches are filled with an amount of smokeless tobacco and the containers are preferably cylindrical, disc cans, which, when fully loaded, contain a predetermined number of the pouches and are intended to be sold to consumers, although implementations are not limited to use with tobacco and aspects described herein can be used with any article in which a predetermined number of the articles are to be packaged in a single container.

[0030] According to aspects described herein, the pouch providing system 10 includes plural lanes L1, L2, . . . , LN, each of which constitutes a separate avenue for pouches to be manufactured and inserted directly into containers. In the non-limiting illustrative embodiment shown in FIG. 1A, the pouch providing system 10 includes ten lanes (L1-L10), although any suitable number of lanes may be used in implementations (such as by way of example, five lanes). Moreover, some of the lanes L1-L10 may be active while other ones of the lanes are inactive. In the non-limiting illustrative embodiment described herein, five of the lanes are active (e.g., lanes L2, L4, L6, L8, and L10) and five of the lanes are inactive (e.g., lanes L1, L3, L5, L7, and L9), although any suitable number of active and inactive lanes (including zero inactive lanes) may be used in implementations. Referring now to FIGS. 1A and 2, each active lane may include a sampling structure 55, one or more count sensors 60, a transfer structure 65, and a hold-back structure (or comb) 70.

[0031] Still referring to FIG. 1A, the conveyor system 15 selectively moves containers into alignment with the lanes L1-L10 for receiving the pouches. In embodiments, the conveyor system 15 includes a plurality of funnel cups 20 attached to a moveable carousel 23. Movement and stopping of the carousel 23 may be achieved by one or more suitable motors and/or actuators, which may be controlled by a controller “C”. The carousel 23, when moving, preferably moves all of the funnel cups 20 simultaneously. In implementations, the conveyor system 15 is structured and arranged such that each funnel cup 20 engages an empty container 25 at an input station 30. The funnel cup 20 is structured and arranged such that the funnel cup 20 and container 25 move together when engaged. In this manner, the carousel moves the empty con-

tainer 25 via the funnel cup 20 from the input station 30 to a filling zone 35 where the container is filled with a predetermined number of pouches. Similarly, the carousel moves the filled container 25 via the funnel cup 20 from the filling zone 35 to a tamping zone 40, and then moves the filled and tamped container 25 from the tamping zone 40 to an outlet 45 where the funnel cup 20 disengages the container 25.

[0032] In the embodiment depicted in FIG. 1A, each funnel cup 20 is pivotally connected to the carousel. Specifically, each funnel cup 20 is pivoted slightly upward (e.g., relative to a substantially horizontal position the funnel cup 20 exhibits at the filling zone 35 and tamping zone 40) as the funnel cup 20 is moved toward the outlet 45 to disengage the funnel cup 20 from the container 25. The funnel cup 20 remains in the upward pivoted position as it moves between the outlet 45 and the input station 30. The funnel cup 20 pivots downward to the substantially horizontal position at the input station 30. The downward pivoting causes the funnel cup 20 to engage an empty container 25 at the input station. The upward and downward pivoting of each funnel cup 20 may be accomplished in any suitable manner, including but not limited to the use of cams, inclined surfaces, actuators, etc. In a preferred embodiment, a procession of open ended cans is directed unto the input station 30 via an inclined ramp or other feed mechanism.

[0033] In another embodiment shown in FIGS. 1B and 10, each funnel cup 20' has an integrated carrier fork 46 structured and arranged to engage one of the containers 25 and to carry (e.g., movably guide) the container 25 through the filling zone 35 (e.g., for the receipt of pouches) and tamping zone 40. These funnel cups 20' are solidly mounted to the carousel 23 and do not pivot to engage the container. Instead, at the input station 30, each container 25 is cammed up (or otherwise elevated) to the bottom of a respective funnel cup 20' via a slight inclined ramp 47 that guides the bottom of the container 25 to a point where the carrier fork 46 moves into engagement with the exterior of the container 25. Once engaged by the carrier fork 46, the container 25 is guided through the filling zone 35 and tamping zone 40 by the carrier fork 46 instead of by contact with the bottom of the funnel cup 20'. As shown in FIG. 10, upon reaching the outlet 45, the container 25 is lowered away from the funnel cup 20' via a slight declined ramp 48. The carrier fork 46 of the funnel cup 20' continues to push the container 25 until the container is engaged on a take-away conveyor that leads to a downstream station, such as the on-line weigh station described in greater detail below with respect to FIG. 9.

[0034] The embodiment of FIGS. 1B and 10 minimizes funnel movement and wear, and allows for minimal contact between the funnel cups 20' and the containers 25. This is advantageous for use with containers having internal coatings (such as paraffin wax) since, with minimal funnel cup contact, such coatings (e.g., wax) do not build up on funnel that may impede the feeding capabilities of the pouches into the containers 25. Moreover, the funnel cups 20' being solidly mounted to the carousel 23 (e.g., without pivoting) results in a robust attachment point.

[0035] FIG. 2 shows exemplary components included in a single active lane and, thus, illustrates a lane (e.g., lane L2) of the system 5 of FIG. 1A. Referring to FIGS. 1 and 2, lane L2 includes a sampling structure 55, one or more count sensors 60, a transfer structure 65, and a hold-back structure (comb)

70. A pouch making machine (e.g., a poucher) 100 manufactures and delivers individual pouches "P" to the sampling structure 55.

[0036] In embodiments, the sampling structure 55 comprises a tube, funnel, or other structure that receives pouches P from the poucher 100 and guides the pouches P to one of two locations. The sampling structure 55 may be pivoted between first and second positions. In the first position, an outlet of the sampling structure 55 is substantially aligned with an inlet of the transfer structure 65 such that pouches P move (e.g., by gravity) from the sampling structure 55 to the transfer structure 65. In the second position, the outlet of the sampling structure 55 is pivoted away from the inlet of the transfer structure 65 such that pouches are diverted to a reject/sample bin (not shown). The pivoting of the sampling structure 55 between the first and second positions may be manually controlled or may be automated (e.g., with an actuator). For example, the sampling structure 55 may be pivoted between the first and second positions by an actuator 57 that is controlled by the controller C, which may comprise a programmable computer device.

[0037] The transfer structure 65 may comprise a tube, funnel, or other structure that receives pouches P from the sampling structure 55 and guides the pouches P to the container 25 via the funnel cup 20. The hold-back structure 70 may be provided at the transfer structure 65 and operates to selectively permit or prevent the passage of pouches P through the transfer structure 65. For example, the hold-back structure 70 may be selectively moveable between first and second positions. In the first position, the hold-back structure 70 substantially blocks the transfer structure 65 such that pouches P can enter but cannot exit the transfer structure 65. In the second position, the hold-back structure 70 is retracted and does not block the flow of pouches through the transfer structure 65 and, instead, permits any pouch P in the transfer structure 65 to fall into the container 25.

[0038] The transfer structure 65 and hold-back structure 70 provide a mechanism for ensuring that pouches P are only directed to the container 25 when the container 25 is substantially aligned (e.g., vertically aligned) with the transfer structure 65. As described in greater detail herein, the poucher 100 continuously produces pouches P, e.g., at a rate of about one pouch per second. Accordingly, the hold-back structure 70 may be closed (e.g., moved to the first position) when the carousel is moving containers between the lanes (e.g., L1-L10) of the system. The pouches P accumulate inside the transfer structure 65 when the hold-back structure 70 is in the first (e.g., closed) position, i.e., to avoid being dropped onto the conveyor system 15 when a container 25 is not in proper position for receiving the pouches. Subsequently, when the carousel 23 has moved the container 25 into substantial alignment with the transfer structure 65 and come to a stop, the hold-back structure 70 is moved from the first (closed) position to the second (open) position and any pouches P that have accumulated in the transfer structure 65 drop into the container 25. Depending on the amount of time that the hold-back structure 70 is held in the second (open) position, other pouches P may pass through the transfer structure 65 and fall into the container 25 without accumulating in the transfer structure 65. In this manner, the poucher 100 may be structured and arranged to continuously produce pouches P even while the conveyor system 15 is moving containers 25 within the system.

[0039] As such, hold-back structure 70 can be structured and arranged so as to block the transfer of pouches P during the period when a filled container 25 is being replaced by an empty container 25. As may be appreciated, when configured in this manner, hold-back structure 70 does not serve to hold-back the entire predetermined number of pouches P that are intended for filling container 25, but rather only those produced during the period when a filled container 25 is being replaced by an empty container 25. As those skilled in the art will plainly recognize, however, hold-back structure 70 can be structured and arranged so as to block the transfer of the entire predetermined number of pouches P that are intended for filling container 25, or any number in between. As such, in embodiments, the hold-back structure may remain at its first, closed position until a predetermined number of pouches have accumulated.

[0040] In embodiments, the hold-back structure 70 comprises a gate having a number of finger-like members that are moved into and out of the transfer structure 65. For example, the transfer structure 65 may comprise a cylindrical tube with a sidewall, and may have holes in the sidewall. The hold-back structure 70 may comprise a number of finger-like members aligned with and moveable through the holes, e.g., in a direction substantially perpendicular to the flow of pouches P through the transfer structure 65. An actuator 72 that is controlled by the controller C may be used to selectively move the finger-like members of the hold-back structure 70 between the first (closed) position in which the finger like members are inside the transfer structure 65, and the second (open) position in which the finger like members are not inside the transfer structure 65. It is noted that the hold-back structure 70 is not limited to the finger-like members described herein, and any mechanism that controllably blocks and unblocks the transfer structure 65 may be used in implementations.

[0041] Still referring to FIG. 2, at least one count sensor 60 may be provided in the lane L2 to detect a number of pouches P that have been inserted into the container 25 or, alternatively or in addition, may count the number of pouches P that have been delivered to the transfer structure 65 since the last release of pouches P by the hold-back structure 70. The count sensor 60 may comprise, for example, a photo-eye structured and arranged to detect the passage of a pouch P between the sampling structure 55 and the transfer structure 65. The count sensor 60 may communicate with the controller C such that the controller C may be configured to detect a number of pouches that have been inserted into the particular container.

[0042] As further illustrated in FIG. 2, the funnel cup 20 may comprise a hollow cylinder, the hollow interior of which guides pouches P from an outlet of the transfer structure 65 to the container 25. In embodiments, the funnel cup 20 includes a lower portion, e.g., a shoulder 80, which fits inside the container 25 and engages an interior wall of the container 25 for moving the container 25 through the system via the carousel 23. For example, the funnel cup 20 and carousel 23 may cause the container to move (e.g., slide) along a surface 85 of the conveyor system 15, e.g., as indicated by arrow 87.

[0043] FIG. 2 also shows an exemplary poucher 100 associated with lane L2. In embodiments, the poucher 100 comprises a paper (or web) source 105 and a tobacco source 110. The paper source 105 may comprise a spool (or bobbin) of paper 107 used in making the pouches P. The tobacco source 110 may comprise a bin 115 having an inlet 120 for receiving tobacco to the bin 115, and an outlet 125 for removing tobacco from the bin 115. A funnel 130 or other conduit may

be provided at the outlet 125. The poucher 100 may be structured and arranged to wrap the paper 107 around a forming section, adjacent a downstream end portion of the funnel 130 to form a tubular paper body 143 while the paper is drawn in a substantially vertical downward direction, e.g., as indicated by arrow 133. The paper is drawn by the drawing action of the rotary cross-sealing bars 147. A rotary tobacco feeder (extruder) 135 moves tobacco inside the bin 115 toward the outlet 125 and into the funnel 130. In an embodiment, the tobacco feeder 135 is a twin screw feeder whose output is adjusted by controlling the amount of rotation of the screws for each feed cycle. The feed cycle is timed by controller C to deliver a predetermined charge of tobacco at or about the time that the rotary cross-sealing bars 147 create a transverse seal across the tubular paper body 143.

[0044] The seal establishes a partially formed, open-ended new pouch 201 (above the sealing bars) and completely closes the pouched structure 203 just below the sealing bars 147. The partially formed open-ended new pouch 201 receives the timed charge of tobacco from the feeder 135 before being closed and sealed upon further rotation of the rotary sealing bars 147. Individual pouches P are cut from the end of the cylindrical rod 140 at a predetermined rate, e.g., about one pouch P per second. After being cut, a pouch P falls (e.g., by gravity) into the sampling structure 55. It is noted, however, that implementations are not limited to the pouchers 100 described herein, and any suitable poucher may be used to provide pouches P to the sampling structure 55. A particularly suitable poucher may be obtained from Ropak Manufacturing Company, Inc. of Decatur, Ala., USA.

[0045] According to aspects described herein, the amount of tobacco discharged from the feeder 135 into the funnel 130 affects the amount of tobacco that is provided in each pouch P, which, in turn, affects the total amount of tobacco that is included in a single container 25. For example, the feeder 135 may comprise a screw-type feeder used for discharging tobacco from the inlet 120 to the outlet 125 and into the funnel 130. The screw of the feeder 135 may be rotated by a motor 160 that is controlled by the controller C. The output of the motor 160 may be increased increase the amount of rotation of the screw of the feeder 135, which increases the flow rate (e.g., mass flow rate) per feed cycle of tobacco into the funnel 130. Alternatively, the output of the motor 160 may be decreased to reduce the amount of rotation of the screw of the feeder 135, to decrease the flow rate of tobacco per cycle into the funnel 130. In lieu or in addition, the speed of the motor 160 may be adjusted to adjust feed rate per cycle.

[0046] The amount of tobacco into the funnel 130 affects the weight of each pouch P made in the poucher 100, such that the feeder 135 may be controlled to affect the weight of the container 25 when a given number of pouches P are inserted into each container. In this manner, and as described in greater detail herein, a container 25 that is filled with a number of pouches at lane L2 may be weighed at a location downstream of the outlet 45, and the speed (and/or duration) of the feeder 135 at lane L2 may be altered (e.g., increased or decreased) based on the weighing, e.g., to ensure that a desired amount of tobacco is being provided in subsequent containers filled at this lane.

[0047] FIG. 2 has been used to describe a single active lane L2. It should be understood, however, that each active lane in the pouch providing system 10 of FIG. 1A may be implemented in a manner similar to that described with respect to FIG. 2. In embodiments, each active lane is provided with a

respective a sampling structure 55, count sensor 60, transfer structure 65, hold-back structure 70, and poucher 100, such that pouches made by the poucher 100 are inserted directly into a container 25. As used herein, the phrase 'inserted directly' may be construed to mean that a container 25 receives pouches P directly from a single poucher or lane 100, and not from a plurality of different pouchers, e.g., the output of pouches from plural pouchers or lanes are not co-mingled. The hold-back structure 70 and feeder 135 in each lane, as well as the conveyor system 15, may all be controlled by the controller C for coordinating the movement of the containers with the manufacturing and dropping of the pouches in each lane. In this manner, plural active lanes may be operating simultaneously and in parallel to one another, continuously producing pouches and inserting the pouches directly into containers. Moreover, by providing a respective poucher in each active lane, the flow rate of tobacco in each active lane may be individually adjusted and controlled exclusively and independently of the other active lanes.

[0048] FIGS. 3-8 show block diagrams depicting an exemplary operation of the system 5 in accordance with aspects described herein. Positions P1, P2, . . . , P30 represent discrete positions where containers (e.g., containers 25) may be positioned by the conveyor system (e.g., conveyor system 15). Positions P1-P10 correspond to lanes L1-L10 in the filling zone 35. As described with respect to FIG. 1A, lanes L2, L4, L6, L8, and L10 are active lanes (e.g., similar to that shown in FIG. 2), and lanes L1, L3, L5, L7, and L9 are inactive lanes (e.g., do not provide pouches to containers). Positions P11-P20 are empty positions downstream of the filling zone 35. Positions P21-P30 correspond to tamping positions in the tamping zone 40. Although the positions P1-P30 are depicted in a linear fashion, it is understood that the conveyor system may have any desired shape, such as an uninterrupted, generally elliptical shape as shown in FIG. 1A.

[0049] As shown in FIG. 3, a first group 310 of ten containers 25 is moved into positions P1-P10, e.g., by the conveyor system moving funnel cups through the input zone 30 to engage empty containers and into the filling zone 35. The respective hold-back structures (e.g., hold-back structures 70) at lanes L2, L4, L6, L8, and L10 are moved to the closed position while the conveyor system advances the containers 25 into the filling zone 35 so that pouches P are retained during movement of the cans. The respective pouchers (e.g., pouchers 100) at lanes L2, L4, L6, L8, and L10 continue to produce pouches while the conveyor system advances the containers 25 into the filling zone 35. When the conveyor system has moved the group 310 to positions P1-P10, the conveyor system stops and the hold-back structures open to release any retained pouches P into a first subset of the containers of the group 310 and to allow additional pouches to be delivered according to a predetermined count.

[0050] When a predetermined number of pouches have been inserted into each container in the first subset of group 310, the hold-back structures are closed, and the conveyor system advances one position as shown in FIG. 4. Advancing one position moves the group 310 to positions P2-P11, such that the first subset of group 310 is taken out of alignment with the active lanes while a second subset of group 310 is simultaneously moved into alignment with the active lanes. Also, a first container of a second group 320 is simultaneously moved to position P1. After advancing the one position, the conveyor

system stops and the hold-back structures open to allow filling of the second subset of containers of the group 310 with pouches.

[0051] After a predetermined number of pouches have been inserted into each container in the second subset of group 310, the hold-back structures are closed, and the conveyor system advances nine positions as shown in FIG. 5. The advancing of nine positions moves the first group 310 to positions P11-P20, which may be intermediate positions where no action is performed on the containers. The advancing of nine positions also simultaneously moves the second group 320 of containers into positions P1-P10. When the conveyor system has moved the second group 320 to positions P1-P10, the conveyor system stops, and the hold-back structures open to allow filling of a first subset of containers of the second group 320 with pouches.

[0052] When a predetermined number of pouches have been inserted into each container in the first subset of second group 320, the hold-back structures are closed, and the conveyor system advances one position as shown in FIG. 6. Advancing the one position moves the second group 320 to positions P2-P11, such that the first subset of the second group 320 is no longer aligned with the active lanes, and a second subset of containers of the second group 320 is aligned with the active lanes. The advancing one position also simultaneously moves the first group 310 to positions P12-P21, and also moves a first container of a third group 330 to position P1. After advancing the one position, the conveyor system stops and the hold-back structures open to allow filling of the second subset of containers of the second group 320 with pouches.

[0053] After a predetermined number of pouches have been inserted into each container in the second subset of the second group 320, the hold-back structures are closed, and the conveyor system advances nine positions as shown in FIG. 7. This is similar to the advancement described between FIG. 4 and FIG. 5, and simultaneously moves the first group 310 to positions P21-P30, the second group 320 to positions P11-P20, and a third group 330 to positions P1-P10. When the conveyor system has moved the third group 330 to positions P1-P10, the conveyor system stops, and the hold-back structures open to allow filling of a first subset of containers of the third group 330 with pouches.

[0054] Additionally, while the conveyor system is momentarily stopped in the position shown in FIG. 7, the containers in both subsets of the first group 310 are tamped at positions P21-P30. The tamping may comprise, for example, a respective linear actuator at each of positions P21-P30 that is controlled to push downward on the pouches in the containers in the tamping zone 40. A disc or other structural member may be attached to the lower end of each one of the linear actuator at positions P21-P30 for tamping the pouches downward into the respective containers. The tamping of the containers in the first group 310 may happen simultaneously with the filling of the first subset of containers of the third group 330.

[0055] Upon filling the first subset of the third group 330 and tamping the first group 310, the hold-back structures are closed and the conveyor system then advances another one position as shown in FIG. 8. This is similar to the advancement described between FIG. 5 and FIG. 6, and simultaneously moves the first group 310 to positions P22-P30, the second group 320 to positions P12-P21, the third group 330 to positions P2-P11, and a first container of a fourth group 340 to position P1. The conveyor system stops after this advance-

ment of one position, and the hold-back structures open to fill a second subset of containers of the third group 330 with pouches.

[0056] The advancement of one position depicted in FIG. 8 also moves a leading container of the first group 310 out of the tamping zone 40. In embodiments, this one container is disengaged from its funnel cup and is conveyed through the outlet station 45 of the system. It should be understood that the next advancement of the conveyor system will be another nine-position advancement (e.g., similar to that described between FIG. 6 and FIG. 7), which will result in the remaining nine containers of the first group 310 being disengaged and conveyed through the outlet 45.

[0057] The flow of containers through the system as described with respect to FIGS. 3-8 is exemplary and is not intended to be limiting. Those skilled in the art will recognize that other movement schemes may be used with the system described herein for moving containers through the system in order to fill the containers. For example, group sizes other than ten containers may be used. Also, there may be no inactive lanes in the filling zone. Moreover, there may be no empty positions between the filling zone and the tamping zone.

[0058] FIG. 9 shows an exemplary on-line weighing system in accordance herewith. In embodiments, the filled containers 25 are disengaged from the conveyor system and output from the system 5 at outlet 45 (e.g., as described with respect to FIG. 1). Downstream of the outlet 45, the containers are moved in single file to a weigh station 400 referred to as a checkweigher. The movement may be provided by any suitable conveyor 405 that extends between the outlet 45 and the weigh station 400, such as a belt, roller, or sliding conveyor. The outlet 45, conveyor 405, and weigh station 400 are structured and arranged such that the order of containers is preserved as the containers move from the outlet 45 to the weigh station 400.

[0059] According to aspects described herein, one or more selectively extendable and retractable gates 410 may be structured and arranged to temporarily stop a single container 25 on a sensor 413 at the weigh station 400. The sensor 413 may be configured to detect a weight of the filled container 25 and communicate this detected weight to the controller C.

[0060] When the controller C determines that the container 25 is satisfactory, then the controller C actuates the gate 410 to cause movement of the container 25 from the weigh station 400 to downstream processes, such as an optional, additional tamping process 415 (e.g., that further tamps down the pouches in container), and a lidding process 416 (e.g., that applies a lid to the container). On the other hand, when the controller C determines that a container is not satisfactory, then the controller C may cause a reject actuator 417 to divert the container 25 to a reject chute 420. The reject actuator 417 may comprise any suitable actuator that is capable of diverting the container 25, such as a pneumatic, hydraulic, or servotype linear actuator with an extendable and retractable push rod that pushes the container off the weigh station 400 and into the reject chute 420, e.g., as indicated by arrow 422.

[0061] In exemplary embodiments, a container may be deemed satisfactory when it both: (i) contains an acceptable number of pouches, and (ii) has a weight within lower and upper limits. The number of pouches in the container may be determined using the count sensor 60. More specifically, since the order of the containers is preserved from the output 40 to the weigh station 400, the controller C may be pro-

grammed to associate a container 25 at the weigh station 400 with a particular filling event at a particular lane of the system 10. Thus, using the data from the count sensors 60 and the position data of each container 25 in the conveyor system 15, the controller C may be configured to determine a number of pouches in each respective container 25. Accordingly, the controller C may be programmed to compare the number of pouches in a container 25 to a predefined acceptable number, and reject the container 25 at weigh station 400 using reject actuator 417 when the number of pouches in the container does not equal the predefined acceptable number.

[0062] As already described herein, the sensor 413 may communicate data to the controller C indicating a weight of the container 25 that is located at the weigh station 400. The controller C may be programmed to compare the weight data to a predefined low threshold and a predefined high threshold. When the weight of the container 25 at the weigh station 400 is less than the low threshold or greater than the high threshold, the controller C may actuate the reject actuator 417 to divert the container 25 to the reject chute 420.

[0063] It is noted that the reject scheme including reject actuator 417 and reject chute 420 are merely exemplary, and implementations are not limited to this particular scheme. For example, rather than diverting containers one at a time, a group of plural containers may be queued at a location downstream of the weigh station, and corresponding plural number of reject actuators may be selectively and individually actuated to reject one or more of the plural containers that were deemed unsatisfactory. The other ones of the plural containers that are not rejected are then passed to the downstream processes.

[0064] According to aspects described herein, the weight of the container 25 determined at weigh station 400 may be used as the basis for adjusting operation of the motor 160 of the poucher 100 in the lane where the particular container 25 was filled. Specifically, since the order of the containers is preserved from the output 40 to the weigh station 400, and since the position of each container is known at all times in the conveyor system 15, the controller C may be programmed to associate a container 25 at the weigh station 400 with a particular lane of the system 10. The controller C may further be programmed to adjust the output of the motor 160 of the poucher 100 in the particular lane based on the detected weight of the container 25 at the weigh station 400. For example, when the controller C determines from sensor 413 that the container 25 weighs less than the low threshold, the controller C may increase the output of the motor 160 during a feed cycle to increase the amount of tobacco that is contained in each pouch made by the particular poucher 100. Alternatively, when the controller C determines from sensor 413 that the container 25 weighs more than the high threshold, the controller C may decrease the output of the motor 160 to decrease the amount of tobacco that is contained in each pouch made by the particular poucher 100.

[0065] Preferably, a predetermined number of weight readings of cans from a given lane are averaged and the average value is compared to a nominal value before adjustment is made to the feed rate of the feeder 135 for that particular lane. Using an average weight reading avoids swings in feeder operation and achieves a smoother response to any tendency of the actual feed rate to move off nominal in any particular lane. Preferably, an average weight of three (3) cans is used, although a greater number is usable. All the while, if any

member can within a set is above or below acceptable weight limits, that can be rejected, but its weight reading is used for control purposes.

[0066] In addition, the controller is configured to track and compare the magnitude of adjustments amongst the feeders **135** to anticipate a problem with one or more of the lanes that might require the attention of the operator or a shut-down of the machine. In one embodiment, each feed rate is monitored and compared to an average of all feed rates, and if any one feed rate (or more) is about 20% or more above or below the average, the machine is shut down and the errant lane identified to the operator for inspection for accumulation of material, clogs or electro-mechanical problems.

[0067] FIG. 10 depicts a block diagram of an exemplary PID (proportional-integral-differential) control algorithm that the controller C may use to adjust the output of the respective motors **160** based on the weight detected at the weight station **400**. In FIG. 10, the Operator Sample Weight is a manual pouch weight entered by the operator when the Sample Mode is selected as Manual. The Checkweigher Sample Weight is a program that evaluates weight data received from the sensor **413** and provides control signals for the PID Control when the Sample Mode is selected as Auto. The Gain Schedule is a program that controls proportional and integral gain based on error (e.g., difference between the actual Sample Weight and a Target Weight), and is configured such that adjustment of the motor **160** is more aggressive when the detected Sample Weight is farther from the Target Weight and less aggressive when the detected Sample Weight is closer to the Target Weight. Fast, Medium, and Slow are threshold components for weight range evaluation. Control Output represents control signals that are transmitted to the particular motor **160** for adjusting the speed of the feeder **135**. It is noted that the control scheme described in FIG. 10 is merely exemplary, and embodiments may be implemented with other control schemes.

[0068] FIG. 11 shows a flow diagram of a method in accordance herewith. Methods in accordance herewith may be performed using the systems described with respect to FIGS. 1-10 and in a manner similar to that described with respect to those figures. The steps of FIG. 11 are described in part by referring to reference numbers associated with elements shown in the previous drawings. At step **510**, plural empty containers are engaged by a conveyor. This may comprise, for example, the carousel **23** moving the funnel cups **20** through the input zone **30** to grab empty containers **25**.

[0069] At step **520**, the plural containers are moved into alignment with a corresponding plural number of continuously operating pouch making machines. This may comprise, for example, the carousel **23** moving simultaneously moving the containers into alignment with the active lanes of the system **10**, in which each active lane includes a poucher **100** that continuously makes pouches at a substantially constant rate.

[0070] At step **530**, the plural containers are simultaneously filled. This may comprise, for example, opening the hold-back structure **70** of each active lane to drop accumulate pouches into the containers **25**, and to permit a number of pouches to drop directly from the pouchers **100** into the containers **25**. In embodiments, each container **25** receives pouches from only a single poucher **100**.

[0071] At step **540**, the filled containers are moved to a tamping zone and the contents of each container are tamped down inside the container. This may comprise, for example,

the carousel **23** moving the filled containers **25** out of the filling zone **35** and into the tamping zone **40**, where the pouches are tamped down into the containers.

[0072] At step **550**, the filled containers are disengaged from the conveyor. This may comprise, for example, the carousel **23** moving the funnel cups **20** through the outlet **45**, where the funnel cups **20** disengage the filled containers. The filled containers may then be moved by another conveyor to the weigh station, with the order of the containers being maintained throughout.

[0073] At step **560**, each filled container is weighed individually. This may comprise, for example, moving each container individually onto a weight sensor **413**.

[0074] At step **570**, a rate of tobacco supplied to a particular one of the pouch making machines is individually adjusted based on the detected weight of a container that was filled at the particular pouch making machine. This may comprise, for example, detecting the weight of a particular container at step **560**, comparing the detected weight to a low and a high threshold, and using the detected weight value to establish and send a control signal to a variable speed motor **160** that drives a tobacco feeder **135** in the poucher **100** that was used to fill the particular container. Each one of the plural pouchers **100** may be individually adjusted based on the detected weights exclusive of the other pouchers **100**.

[0075] Referring now to FIG. 12 a sequencing diagram for an embodiment of a system and method, in accordance herewith, is shown. At step **610**, after the pouches are formed with a longitudinal (fin) seal and the end seals, they advance to the knives where they are cut and separated. The programmable logic controller (PLC) program counts how many pouches have been cut by counting how many times the knives make a full revolution. At step **610**, this value is compared to the number of pouches detected by the pouch sensor. If the two values are equal, then, at step **610**, the container is marked as 'Good'. If the values are not equal, the container will be marked as an external reject, at step **630**, and will be rejected at step **690** by the checkweigher, regardless of its weight.

[0076] FIG. 13 depicts how the containers transition to different stations on the conveyor from machine startup. The container unit has 40 total cups, but holds three sets of 10 containers, plus some new empty containers from the container infeed before lane **10**, which consists of the set being filled, the set being evaluated for count, and the set ready to exit. As shown, Set 0 is the set being filled under lanes 1-10. Set 1 is first set after filling, being evaluated for proper count at lanes 1-8, and prior to the tamping section. Set 2 refers to a second set of containers after filling, with lane 9 and 10 being tamped, lanes 2-8 waiting for exit, and 1 exiting by itself only during the first time the container unit is loaded. Set 3 refers to a third set after filling. The containers exit in order 2, 3, 4, 5, 6, 7, 8, 9, 10, 1 and head towards the checkweigher (not shown).

[0077] In operation, each time the container conveyor moves in sets of 10 cups, for each cup that moves, the cup sensor and container sensor must both be on, seeing a cup and a container. Once a set of 10 containers is loaded, any containers missing from the newly loaded set will stop the machine for missing container(s). If this occurs, the hold back structure, or combs, holding pouches while the containers move, do not retract, keeping pouches from dropping on the container conveyor track. Should this occur, the operator must correct the container feed issue and restart the machine. The container unit will load 10 new empty containers. If any

are detected missing, the machine stops again. If 10 containers are successfully loaded, then the hold back structure, or combs, will retract and pouches will drop into containers and production continues.

[0078] After a set of containers have been filled with pouches, the container conveyor advances them to be tamped. Each tamp head presses down into a container and packs the pouches tighter together. This is done to prevent pouches from sticking out of the containers. The number of times a set of containers is tamped can vary based on the speed that the machine is operating. As may be appreciated, the tamp heads must be up in order for the container conveyor to execute a move. When containers are being tamped, the tamp heads should be able to enter the containers with 1 millimeter of clearance between the outside of the tamp head and the container.

[0079] After the pouches are tamped they enter the exit conveyor which carries them to the checkweigher. Containers that have already been marked as “external rejects” will automatically be rejected. The remaining containers marked as “good” will be weighed on the checkweigher to determine if the pouch weights are within an acceptable range of weights. If they are, they will continue on the conveyor. If not, they will be rejected off of the checkweigher. When a container’s weight is out of the accepted range, the checkweigher sends needed adjustment information to the poucher which in turn adjusts its feed mechanism to produce tobacco pouches closer to a target pouch weight.

[0080] The particulars shown herein are by way of example and for purposes of illustrative discussion only and are presented in the cause of providing what is believed to be the most useful and readily understood description of the principles and conceptual aspects. In this regard, no attempt is made to show structural details in more detail than is necessary for fundamental understanding, the description taken with the drawings making apparent to those skilled in the art how the several forms disclosed herein may be embodied in practice.

[0081] It is noted that the foregoing examples have been provided merely for the purpose of explanation and are in no way to be construed as limiting. While aspects have been described with reference to an exemplary embodiment, it is understood that the words which have been used herein are words of description and illustration, rather than words of limitation. Changes may be made, within the purview of the appended claims, as presently stated and as amended, without departing from the scope and spirit of the present disclosure in its aspects. Although aspects have been described herein with reference to particular means, materials, and/or embodiments, the present disclosure is not intended to be limited to the particulars disclosed herein; rather, it extends to all functionally equivalent structures, methods and uses, such as are within the scope of the appended claims.

What is claimed:

1. A system for manufacturing and inserting a pre-determined number of material-filled pouches into containers, the system comprising:

a pouch providing system comprising a plurality of lanes, wherein each one of the plurality of lanes comprises a pouch making machine and a hold-back structure;

a conveyor system structured and arranged to move a plurality of containers into alignment with the plurality of lanes; and

a controller structured and arranged to control the hold-back structure in each one of the plurality of lanes such that the predetermined number of pouches are inserted into each of the plurality of containers when the plurality of containers are aligned with the plurality of lanes.

2. The system of claim 1, wherein:

the pouch making machines make the pouches at a substantially constant rate independent of a position of the plurality of containers; and

the pouches made by the pouch making machine in a respective one of the plurality of lanes are inserted directly into the respective container aligned with the respective lane.

3. The system of claim 2, wherein:

the hold-back structure is moveable between an open position and a closed position;

the open position permitting the pouches to be inserted into a respective container aligned with the respective lane; and

the closed position preventing the pouches from passing through the respective lane and causing the pouches to accumulate inside the respective lane while a full container is removed and an empty container is brought into alignment with the respective lane.

4. The system of claim 3, wherein:

the controller is structured and arranged to move the hold-back structure to the closed position when the conveyor system is moving the plurality of containers; and

the controller is structured and arranged to move the hold-back structure to the open position when the plurality of containers are aligned with the plurality of lanes.

5. The system of claim 2, further comprising a weigh station structured and arranged to detect a weight of each one of the plurality of containers after the pouches are inserted into the plurality of containers.

6. The system of claim 5, wherein:

the pouch making machine of each one of the lanes comprises a tobacco feeder structured and arranged to control an amount of tobacco that is included in each of the pouches made by the pouch making machine; and

the controller is structured and arranged to adjust an output of the tobacco feeder in a respective one of the lanes based on the detected weight of one of the containers that was filled at the respective lane.

7. The system of claim 5, wherein the controller is structured and arranged to:

compare the detected weight of a respective one of the containers to a low threshold and a high threshold; and reject the respective container when the detected weight is less than the low threshold or greater than the high threshold.

8. The system of claim 5, wherein:

each of the plurality of lanes comprises a count sensor structured and arranged to detect a count of the pouches released from the pouch providing system that are to be inserted into a respective one of the plurality of containers; and

the controller is structured and arranged to reject the respective container when the detected count does not equal a predefined value.

9. The system of claim 8, wherein the controller is structured and arranged to compare said count of released pouches to a detected number of pouch cutting operations and, if unequal, to reject the respective container.

10. The system of claim **1**, wherein the conveyor system is structured and arranged to move the plurality of containers away from the plurality of lanes and into a tamping zone where tampers are structured and arranged to tamp the pouches inside of the plurality of containers.

11. The system of claim **1**, wherein the conveyor system is structured and arranged to simultaneously move the plurality of containers away from the plurality of lanes and move a second plurality of containers into alignment with the plurality of lanes.

12. The system of claim **1**, wherein:
the pouches include smokeless tobacco contained within a paper case; and
the containers comprise cylindrical containers structured and arranged to be sealed with a lid.

13. The system of claim **1**, wherein:
each one of the plurality of lanes comprises a sampling structure and a transfer structure;
the transfer structure contains the hold-back structure; and
the sampling structure is moveable between a first position in which the pouches made in the respective lane are directed to the transfer structure and a second position in which the pouches made in the are directed away from the transfer structure.

14. The system of claim **1**, wherein:
the conveyor system comprises a carousel and a plurality of funnel cups attached to the carousel;
each respective one of the funnel cups is structured and arranged to engage a respective one of the plurality of containers; and
the controller is structured and arranged to control movement of the plurality of containers by moving and stopping of the carousel.

15. The system of claim **14**, wherein each funnel cup includes an integrated carrier fork structured and arranged to engage one of the containers.

16. The system of claim **15**, wherein each funnel cup is solidly mounted to said carousel and does not pivot to engage the container.

17. A method for manufacturing and inserting material-filled pouches into containers, the method comprising:
engaging a plurality of containers with a conveyor system;
simultaneously moving the plurality of containers into alignment with a corresponding plurality of pouch making machines;
inserting pouches directly from respective ones of the plurality of pouch making machines into respective ones of the plurality of containers;
individually weighing each one of the plurality of containers after the inserting; and

adjusting a rate of material supplied to a respective one of the plurality of pouch making machines based on the weighing.

18. The method of claim **17**, wherein the adjusting the rate of material comprises adjusting a speed of a material feeder included in the respective pouch making machine exclusive of speeds of other material feeders included in other ones of the pouch making machines.

19. The method of claim **18**, further comprising:
comparing a detected weight of a respective one of the plurality of containers that received the pouches from the respective pouch making machine to a low threshold and a high threshold;

increasing a speed of the material feeder included in the respective pouch making machine when the detected weight is less than the low threshold; and

decreasing the speed of the material feeder included in the respective pouch making machine when the detected weight is greater than the high threshold.

20. The method of claim **19**, wherein the increasing the speed and the decreasing the speed are based on a proportional-integral-differential (PID) control.

21. The method claim **16**, wherein said increasing and decreasing is based on an average weight of at least three containers from a respective pouch making machine.

22. The method of claim **21**, wherein the controller is structured and arranged to compare current feed rates of each pouch making machine to determine whether a need to shut down a pouch making machine in response to said feed rate comparison exists.

23. The method of claim **17**, further comprising:
moving the plurality of containers out of alignment with the plurality of pouch making machines and into alignment with a plurality of tamping devices; and
tamping the pouches in each one of the plurality of containers.

24. The method of claim **23**, further comprising disengaging the plurality of containers from the conveyor system after the tamping and prior to the weighing.

25. The method of claim **17**, further comprising:
actuating a plurality of hold-back structures to a closed position such that the pouches accumulate in transfer structures during the moving the plurality of containers; and

actuating the plurality of hold-back structures to an open position when the plurality of containers is aligned with the pouch making machines.

* * * * *