



US 20050272602A1

(19) **United States**
 (12) **Patent Application Publication** (10) **Pub. No.: US 2005/0272602 A1**
Ninomiya (43) **Pub. Date: Dec. 8, 2005**

(54) **HONEYCOMB STRUCTURAL BODY AND EXHAUST GAS PURIFYING DEVICE**

Publication Classification

(75) Inventor: **Takeshi Ninomiya, Ibi-Gun (JP)**

(51) **Int. Cl.⁷ B01J 21/02**

(52) **U.S. Cl. 502/439; 502/202**

Correspondence Address:

**OBLON, SPIVAK, MCCLELLAND, MAIER & NEUSTADT, P.C.
1940 DUKE STREET
ALEXANDRIA, VA 22314 (US)**

(57) **ABSTRACT**

(73) Assignee: **IBIDEN CO., LTD., Ogaki-shi (JP)**

The present invention provides a pillar-shaped honeycomb structural body made of porous ceramics in which a large number of through holes are placed in parallel with one another in the length direction with a wall portion interposed therebetween. Herein, the honeycomb structural body is provided with a sealing material layer which includes inorganic fibers containing at least about 60% and at most about 85% by weight of silica and at least about 15% and at most about 40% by weight of at least one kind of compound selected from the group consisting of an alkali metal compound, an alkali-earth metal compound and a boron compound.

(21) Appl. No.: **11/127,236**

(22) Filed: **May 12, 2005**

(30) **Foreign Application Priority Data**

May 18, 2004 (JP) 2004-147884
Nov. 26, 2004 (WO) PCT/JP04/17620

Fig. 1A

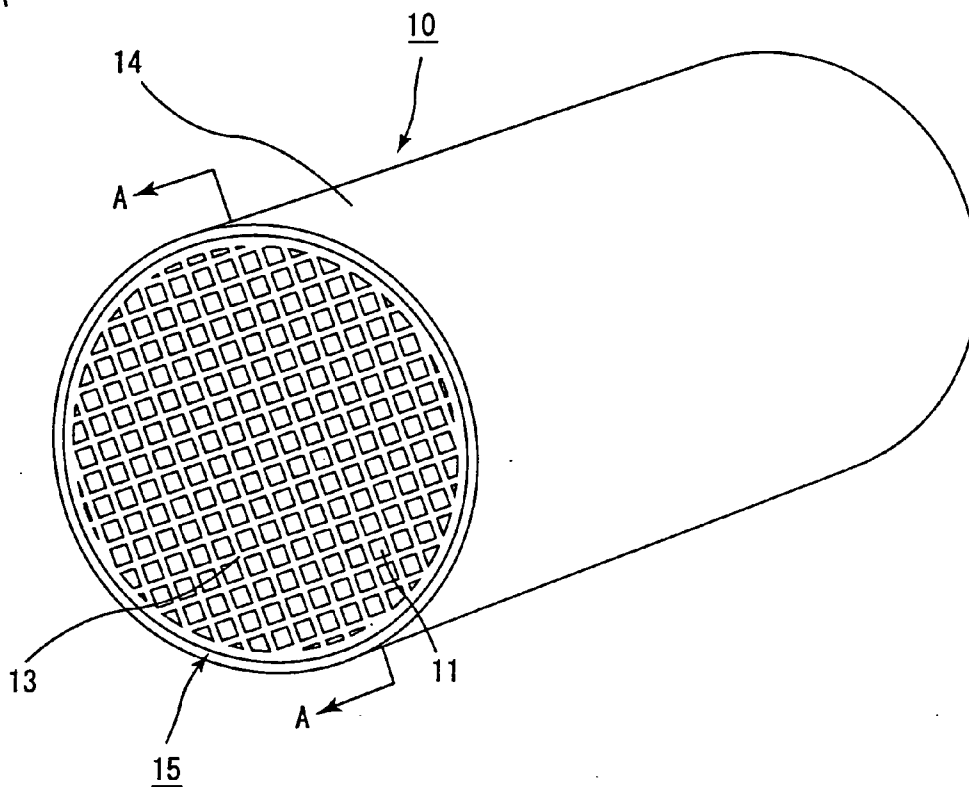

Fig. 1B

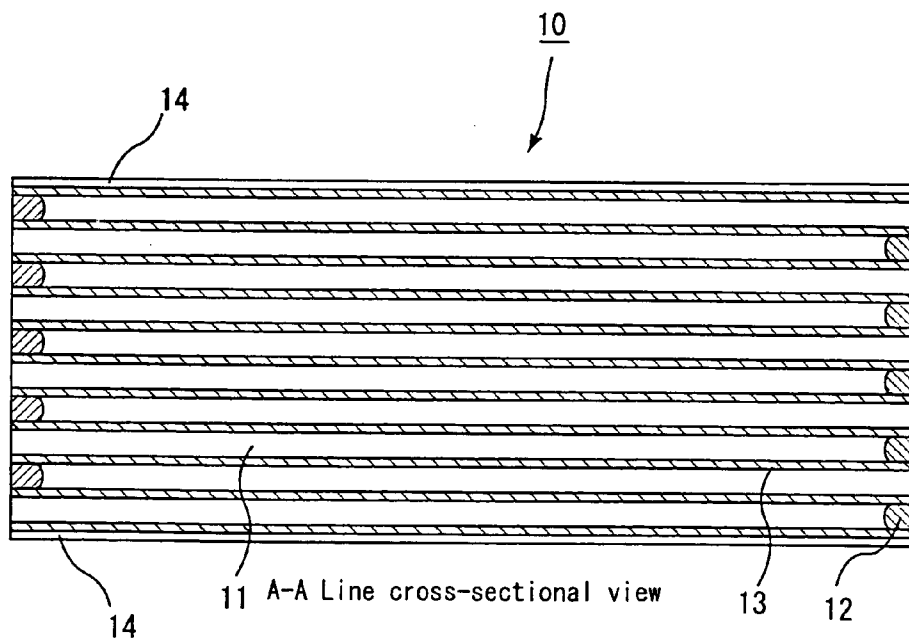

Fig. 2

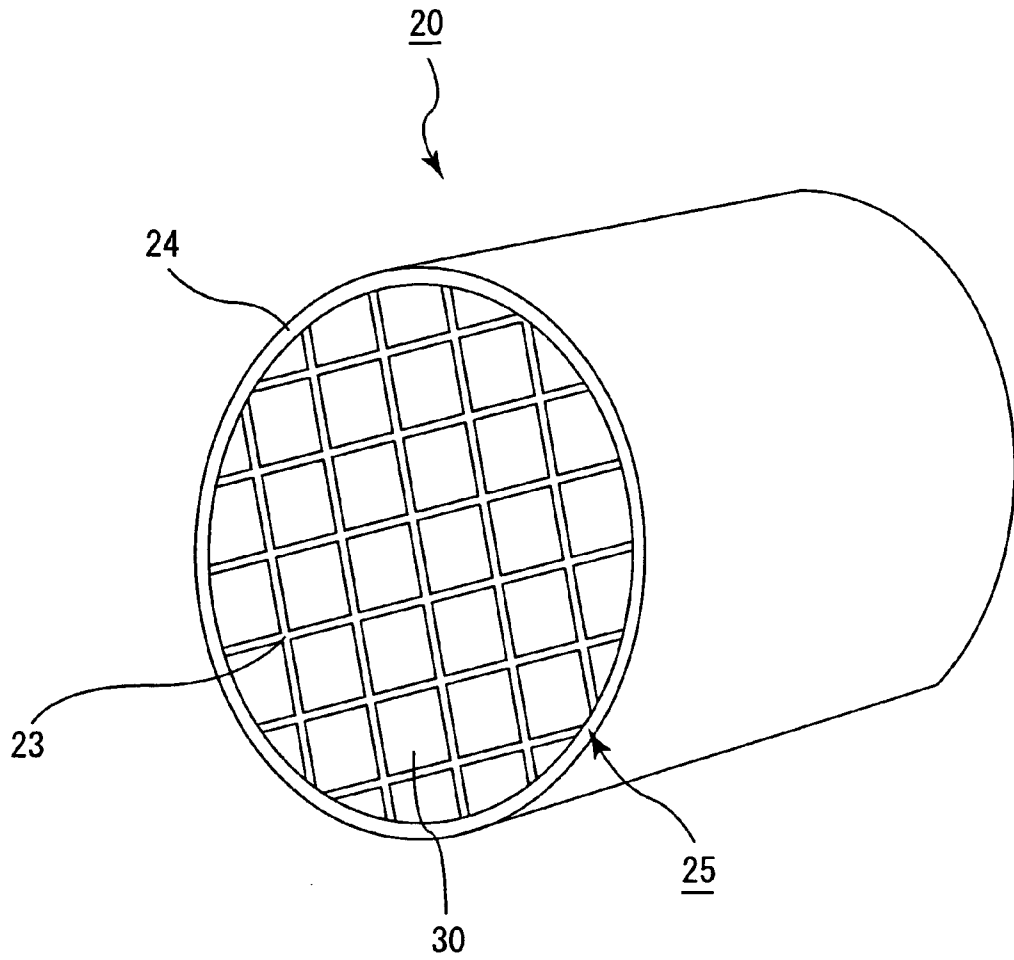

Fig. 3A

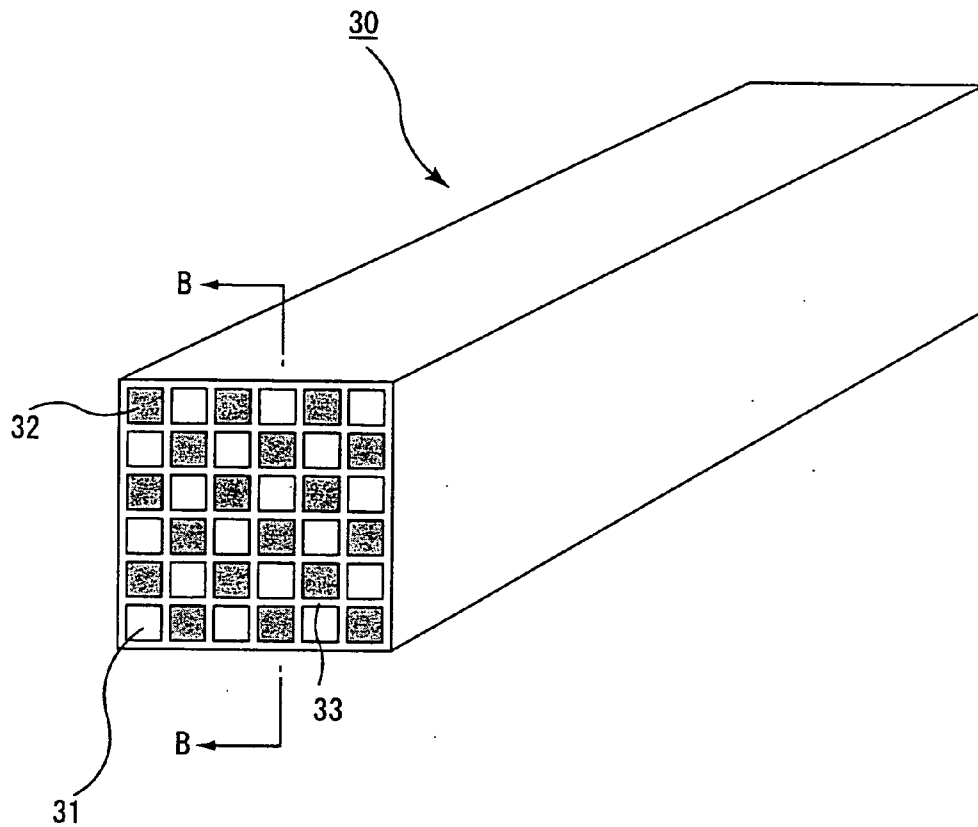
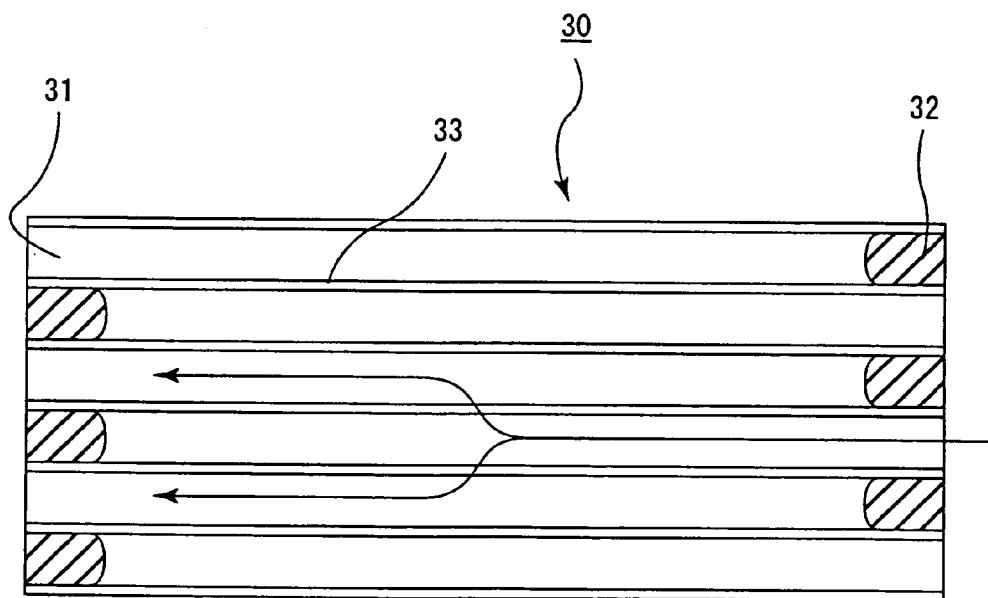

Fig. 3B



B-B Line cross-sectional view

Fig. 4A

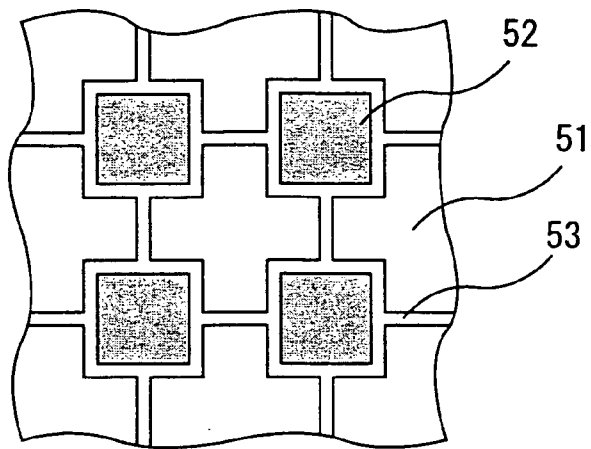

Fig. 4B

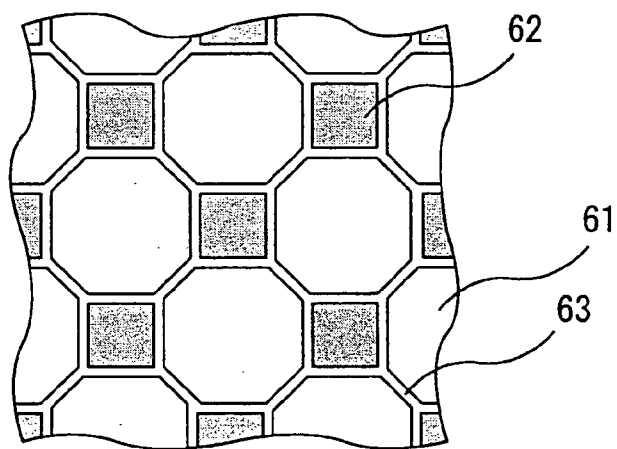

Fig. 4C

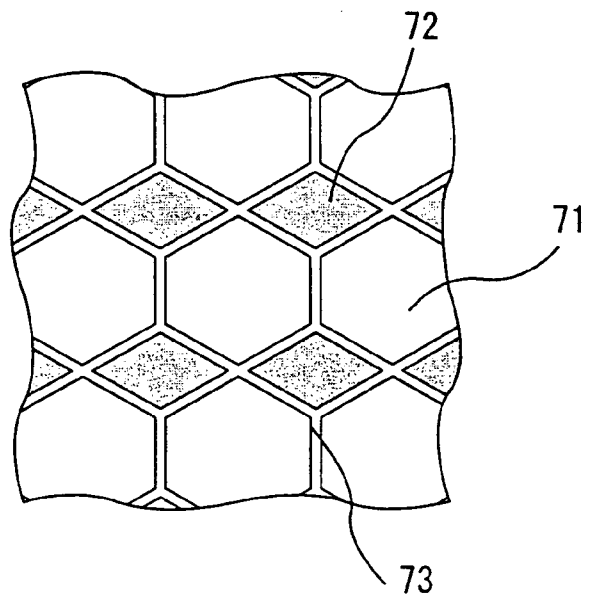

Fig. 5A

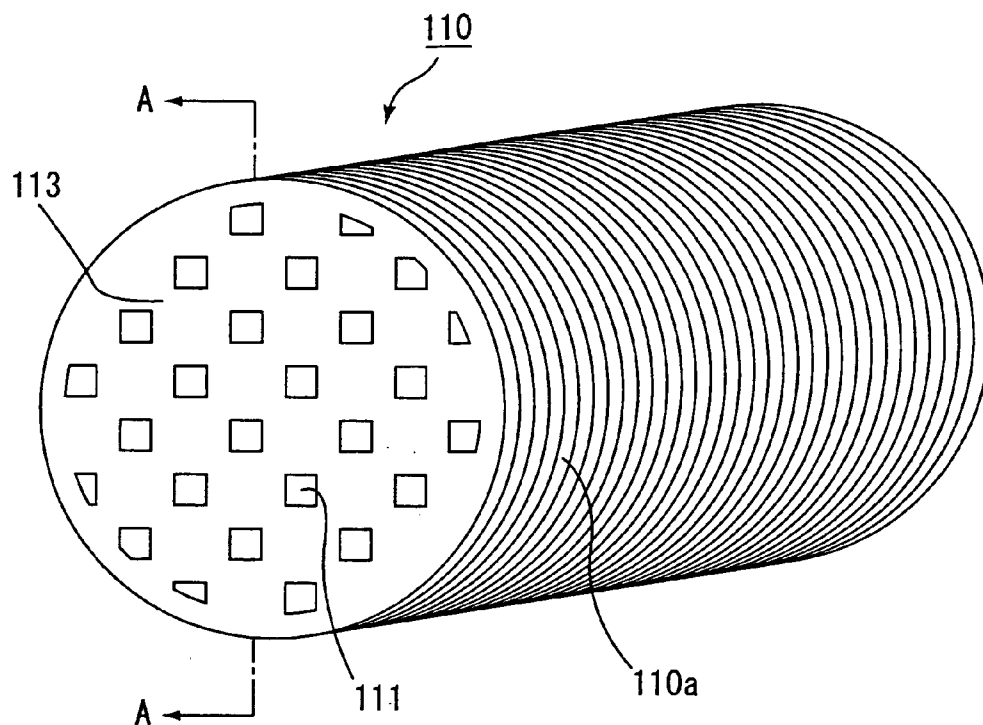
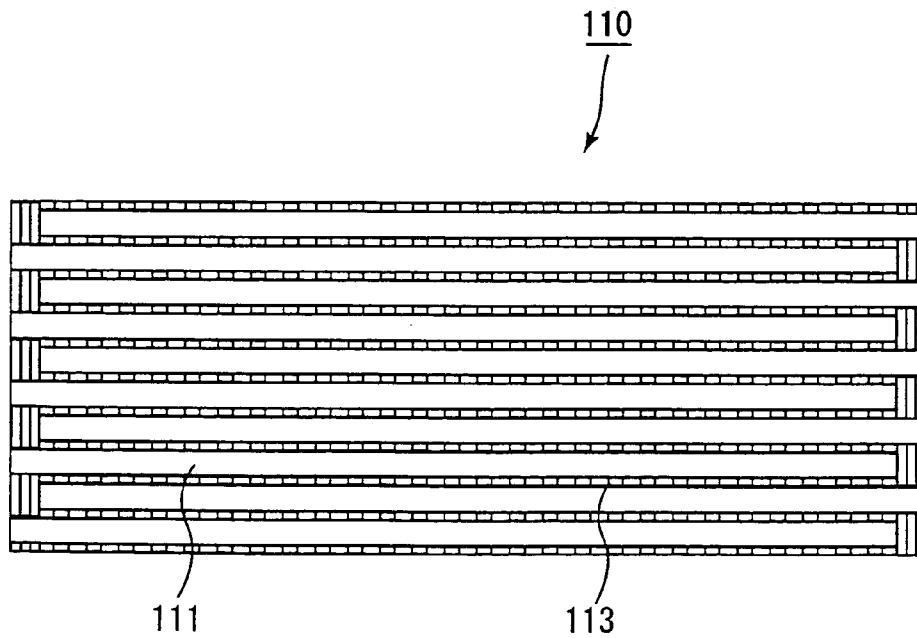

Fig. 5B



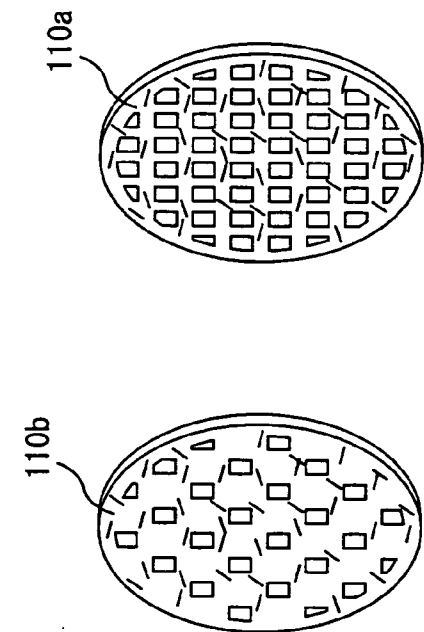

Fig. 6A

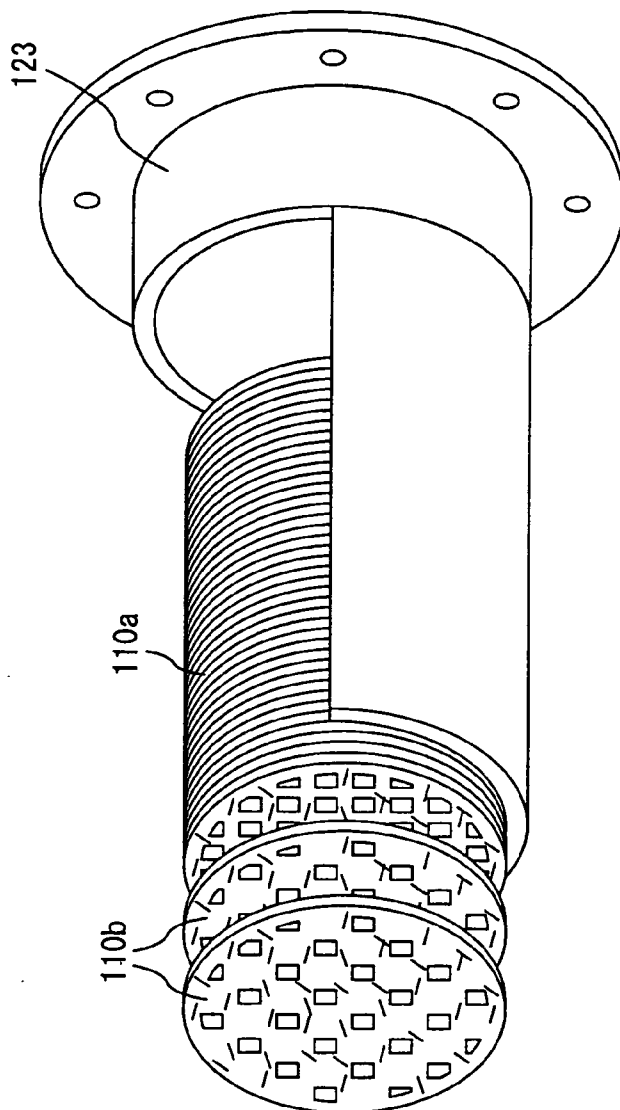

Fig. 6B

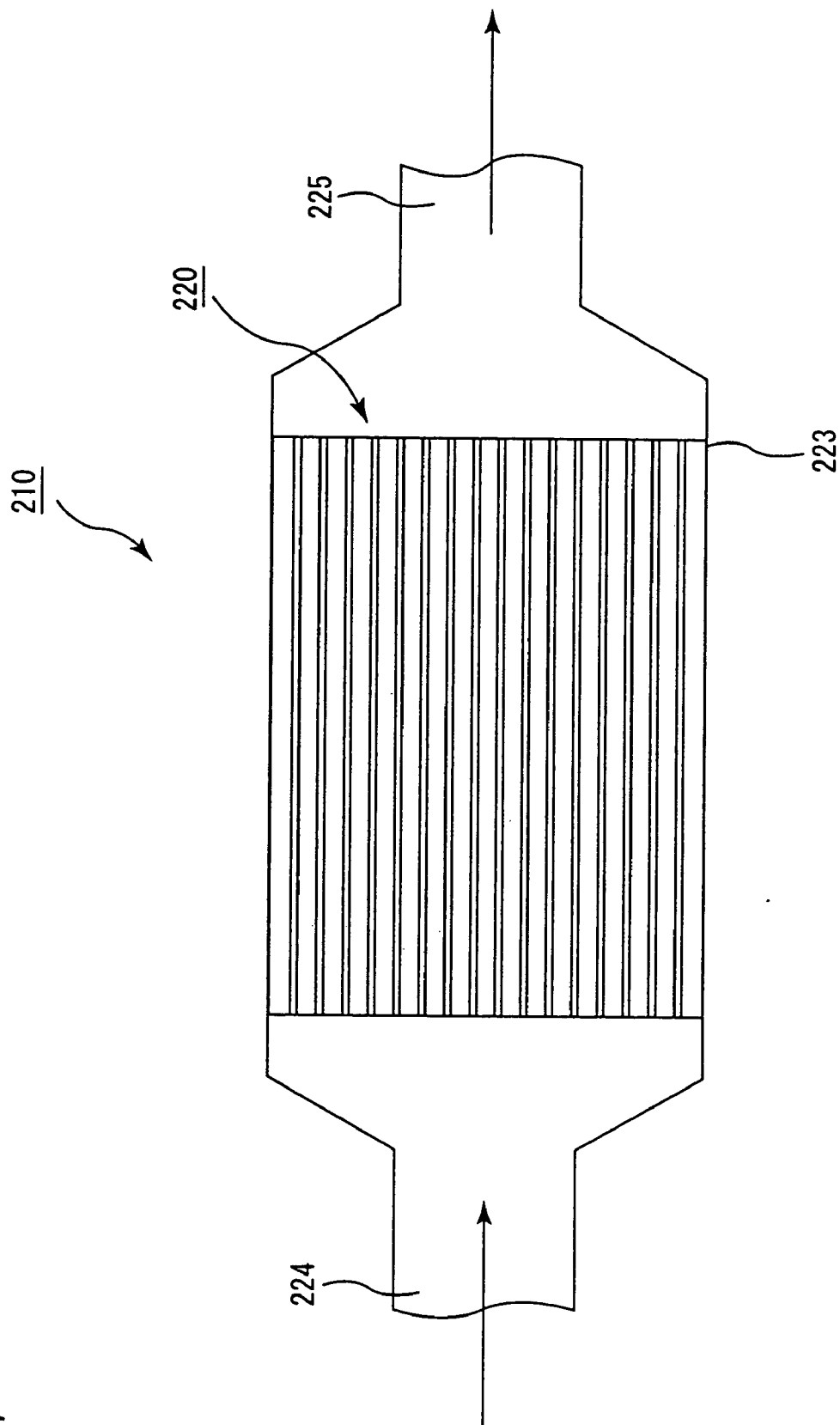

Fig. 7

Fig. 8A

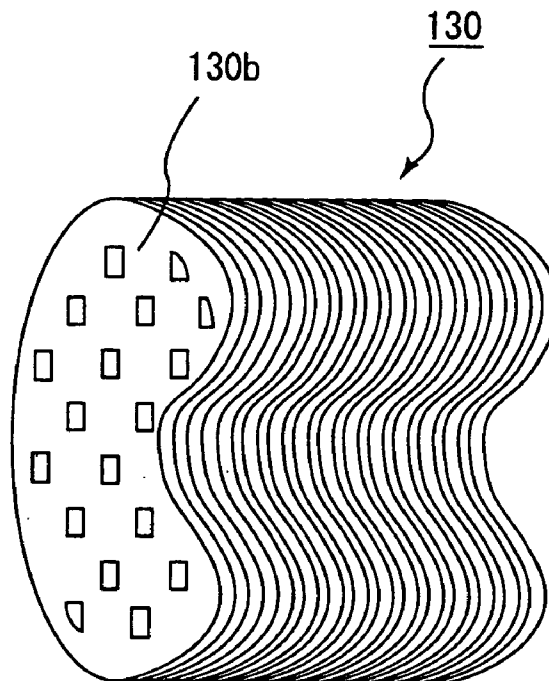

Fig. 8B

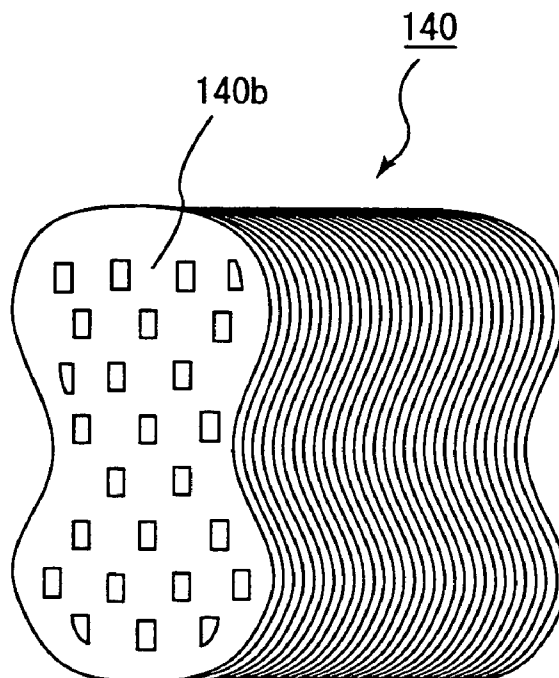

Fig. 9

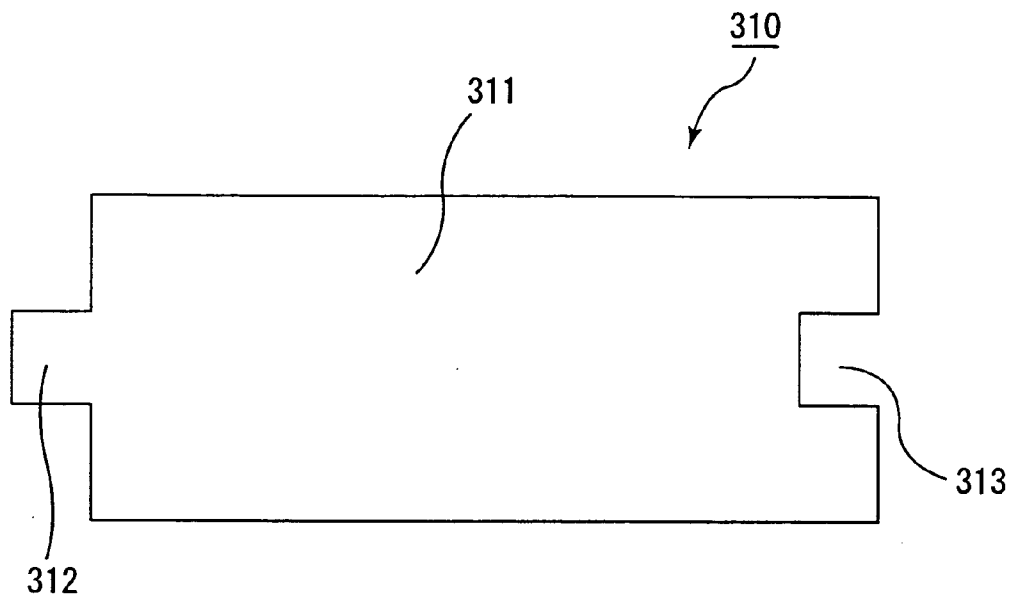

Fig. 10

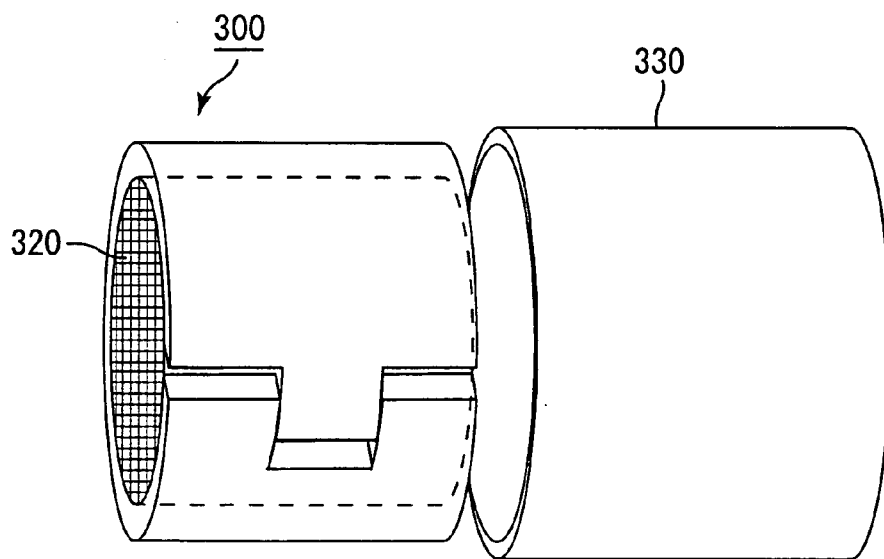

Fig. 11

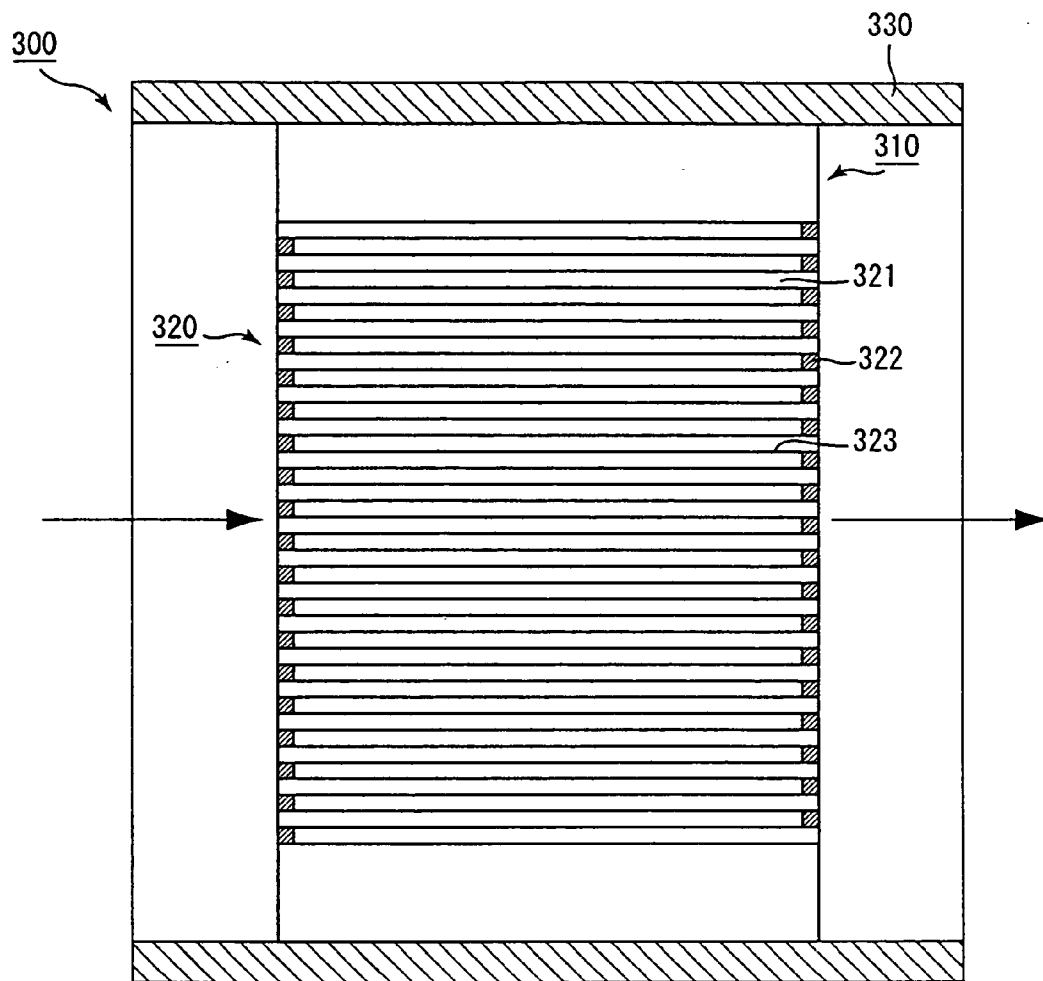

Fig. 12

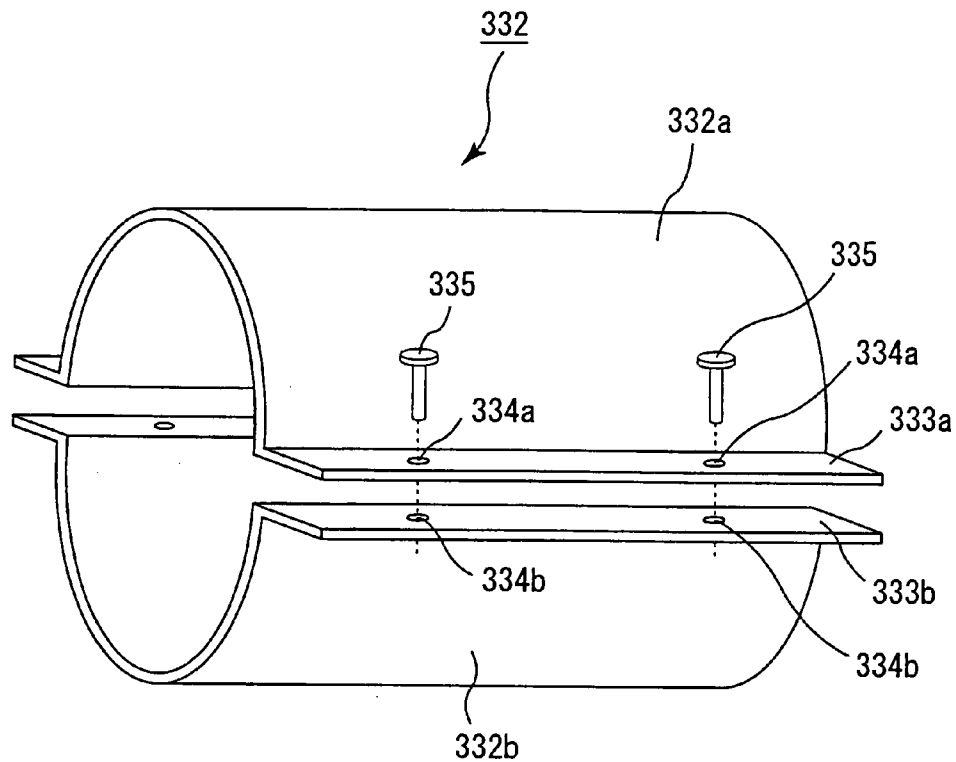
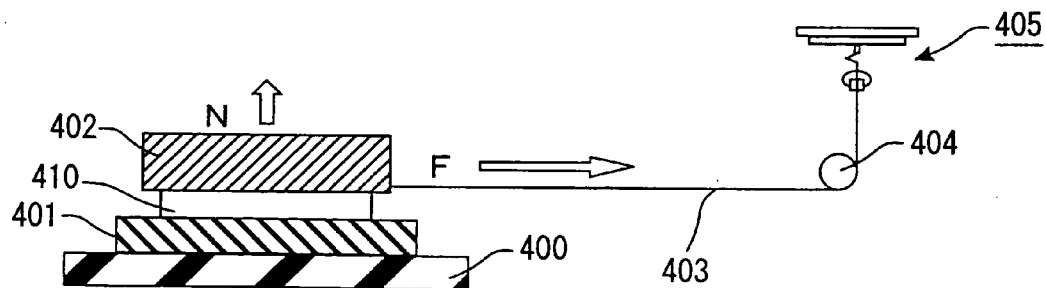

Fig. 13



HONEYCOMB STRUCTURAL BODY AND EXHAUST GAS PURIFYING DEVICE

CROSS-REFERENCE TO RELATED APPLICATIONS

[0001] This application claims benefit of priority to Japanese Patent Application No. 2004-147884, filed on May 18, 2004, and PCT Application No. PCT/JP2004/017620 filed on Nov. 26, 2004.

[0002] The contents of those Applications are incorporated herein by reference in their entirety.

BACKGROUND OF THE INVENTION

[0003] 1. Field of the Invention

[0004] The present invention relates to a honeycomb structural body and an exhaust gas purifying device.

[0005] 2. Discussion of the Background

[0006] In a honeycomb structural body that removes particulates and the like in exhaust gases discharged from an internal combustion system such as a diesel engine or the like as well as in an exhaust gas purifying device that uses this honeycomb structural body, inorganic fibers are used as materials for various structural members.

[0007] More specifically, for example, a sealing material containing inorganic fibers is used as a sealing material (adhesive) used for binding a plurality of ceramic blocks to form a honeycomb structural body and as a sealing material to be formed on the peripheral portion of the honeycomb structural body.

[0008] Moreover, in an exhaust gas purifying device in which a honeycomb structural body is housed in a metal shell, a holding seal, mainly composed of inorganic fibers, is used as a holding sealing material interposed between the honeycomb structural body and the metal shell (see, for example, JP-A 2002-200409).

[0009] In the case where inorganic fibers having a small average fiber diameter (for example, 6 μm or less) are used as such inorganic fibers, if these inorganic fibers are taken into the human body, the inorganic fibers will remain in the lung and the like to give adverse effects on the human body.

[0010] The contents of JP-A 2002-200409 are incorporated herein by reference in their entirety.

SUMMARY OF THE INVENTION

[0011] The present inventors have found that, when inorganic fibers, which will be decomposed in the human body, are used, it is possible to ensure safety even if they are taken into the human body; thus, the present invention has been completed.

[0012] In other words, a honeycomb structural body according to a first aspect of the present invention is as follows:

[0013] a pillar-shaped honeycomb structural body made of porous ceramics and comprising a large number of through holes that are placed in parallel with one another in the length direction with a wall portion interposed therebetween,

[0014] wherein

[0015] the honeycomb structural body has a sealing material layer formed thereon, and

[0016] the sealing material contains

[0017] inorganic fibers comprising:

[0018] at least about 60% and at most about 85% by weight of silica; and

[0019] at least about 15% and at most about 40% by weight of at least one kind of compound selected from the group consisting of an alkali metal compound, an alkali-earth metal compound and a boron compound.

[0020] In the present invention, the honeycomb structural body desirably comprises a plurality of pillar-shaped porous ceramic members that are combined to one another through a sealing material layer, each of the pillar-shaped porous ceramic members including a large number of through holes that are placed in parallel with one another in the length direction with a partition wall interposed therebetween.

[0021] It is desirable that the through holes are alternately sealed at end portions, and the partition wall that separates the through holes functions as a filter.

[0022] A catalyst is desirably supported on the honeycomb structural body.

[0023] Aperture ratios of through holes on both end faces are desirably different from each other. It is more desirable that the aperture ratio of through holes on the end face of a gas inlet side is greater.

[0024] The porous ceramic material desirably comprises at least one kind selected from the group consisting of nitride ceramics, carbide ceramics and oxide ceramics. The porous ceramic material desirably comprises silicon carbide. The porous ceramic material desirably comprises cordierite.

[0025] The alkali metal compound desirably includes at least one kind selected from the group consisting of oxides of Na and oxides of K. The alkali-earth metal compound desirably includes at least one kind selected from the group consisting of oxides of Mg, oxides of Ca and oxides of Ba. The boron compound desirably includes an oxide of B.

[0026] Solubility of the inorganic fibers in physiological saline is desirably at least about 30 ppm.

[0027] The inorganic fibers desirably have a function of absorbing and storing NO_x contained in an ambient gas.

[0028] The content of the inorganic fibers in the sealing material layer is desirably at least about 10% and at most about 70% by weight. The content of the inorganic fibers in the sealing material layer is more desirably in the range of about 20% to 40% by weight, and more desirably in the range of about 20% to 30% by weight.

[0029] The sealing material layer desirably comprises an inorganic binder, an organic binder and inorganic particles in addition to the inorganic fibers.

[0030] Moreover, a honeycomb structural body according to a second aspect of the present invention is as follows:

[0031] a pillar-shaped honeycomb structural body mainly made of inorganic fibers and comprising a

plurality of through holes that are placed in parallel with one another in the length direction with a wall portion interposed therebetween,

[0032] wherein

[0033] the inorganic fibers comprise

[0034] at least about 60% and at most about 85% by weight of silica; and

[0035] at least about 15% and at most about 40% by weight of at least one kind of compound selected from the group consisting of an alkali metal compound, an alkali-earth metal compound and a boron compound.

[0036] In the present invention, it is desirable that the through holes are alternately sealed at end portions. It is desirable that a catalyst is supported on the honeycomb structural body.

[0037] The average fiber length of the inorganic fibers is desirably at least about 0.1 mm and at most about 100 mm, and more desirably in the range of about 0.5 to 50 mm. The average fiber diameter of the inorganic fibers is desirably at least about 1 μm and at most about 30 μm , and more desirably in the range of about 2 to 10 μm .

[0038] The alkali metal compound desirably includes at least one kind selected from the group consisting of oxides of Na and oxides of K. The alkali-earth metal compound desirably includes at least one kind selected from the group consisting of oxides of Mg, oxides of Ca and oxides of Ba. The boron compound desirably comprises an oxide of B.

[0039] Solubility of the inorganic fibers in physiological saline is desirably at least about 30 ppm.

[0040] The inorganic fibers desirably have a function of absorbing and storing NOx contained in an ambient gas.

[0041] It is desirable that the honeycomb structural body further comprises an inorganic binder that binds the inorganic fibers to each other in addition to the inorganic fibers. The inorganic binder desirably comprises at least one kind selected from the group consisting of silicate glass, alkali silicate glass, borosilicate glass, alumina sol, silica sol and titania sol.

[0042] Furthermore, an exhaust gas purifying device according to a third aspect of the present invention is as follows:

[0043] an exhaust gas purifying device comprising:

[0044] a honeycomb structural body;

[0045] a cylindrical metal shell that covers a periphery of the honeycomb structural body in the length direction; and

[0046] a holding sealing material placed between the honeycomb structural body and the metal shell,

[0047] wherein

[0048] the holding sealing material mainly includes inorganic fibers comprising:

[0049] at least about 60% and at most about 85% by weight of silica; and

[0050] at least about 15% and at most about 40% by weight of at least one kind of compound selected from the group consisting of an alkali metal compound, an alkali-earth metal compound and a boron compound.

[0051] In the present invention, the holding sealing material desirably has a convex portion formed on one of short sides of a base material member having approximately a rectangular shape and a concave portion formed on the other short side so that the convex portion and the concave portion fit to each other when the base material member is wound around the periphery of the honeycomb structural body.

[0052] The inorganic fibers desirably have a fiber tensile strength of at least about 1.2 GPa and at most about 200 GPa, and more desirably have a fiber tensile strength in the range of about 1.5 to 150 GPa.

[0053] The average fiber length of the inorganic fibers is desirably at least about 0.5 mm and at most about 100 mm, and more desirably in the range of about 10 to 40 mm.

[0054] The average fiber diameter of the inorganic fibers is desirably at least about 0.3 μm and at most about 25 μm , and more desirably in the range of about 0.5 to 15 μm .

[0055] The alkali metal compound desirably includes at least one kind selected from the group consisting of oxides of Na and oxides of K. The alkali-earth metal compound desirably includes at least one kind selected from the group consisting of oxides of Mg, oxides of Ca and oxides of Ba. The boron compound desirably includes an oxide of B.

[0056] Solubility of the inorganic fibers in physiological saline is desirably at least about 30 ppm.

[0057] The inorganic fibers desirably have a function of absorbing and storing NOx contained in an ambient gas.

[0058] It is desirable that the exhaust gas purifying device further comprises: an organic binder that binds the inorganic fibers to each other in addition to the inorganic fibers. The organic binder desirably comprises at least one kind selected from the group consisting of styrene-butadiene resins and acrylonitrile-butadiene resins. The organic binder desirably has a decomposing temperature of about 200° C. or more. The content of the organic binder is desirably about 10% by weight or less, more desirably about 5% by weight or less, and more desirably about 1% by weight or less.

BRIEF DESCRIPTION OF THE DRAWINGS

[0059] FIG. 1A is a perspective view that schematically shows a honeycomb structural body according to a first aspect of the present invention.

[0060] FIG. 1B is a cross-sectional view taken along line A-A of the honeycomb structural body shown in FIG. 1A.

[0061] FIG. 2 is a perspective view that schematically shows one example of a honeycomb structural body according to a second aspect of the present invention.

[0062] FIG. 3A is a cross-sectional view that schematically shows a porous ceramic member to be used for the honeycomb structural body of the second aspect of the present invention shown in FIG. 2.

[0063] FIG. 3B is a cross-sectional view taken along line B-B of FIG. 3A.

[0064] FIG. 4A is a partially enlarged view that schematically shows one example of an end face on the gas inlet side of a honeycomb structural body of the present invention in which through holes, the end portions of which are sealed on one side of the faces, and through holes, the end portions of which are sealed on the other side, have mutually different opening diameters.

[0065] FIG. 4B is a partially enlarged cross-sectional view that schematically shows another example of an end face on the gas inlet side of a honeycomb structural body of the present invention in which through holes, the end portions of which are sealed on one side of the faces, and through holes, the end portions of which are sealed on the other side, have mutually different opening diameters.

[0066] FIG. 4C is a partially enlarged cross-sectional view that schematically shows the other example of an end face on the gas inlet side of a honeycomb structural body of the present invention in which through holes, the end portions of which are sealed on one side of the faces, and through holes, the end portions of which are sealed on the other side, have mutually different opening diameters.

[0067] FIG. 5A is a perspective view that schematically shows a honeycomb structural body according to the second aspect of the present invention.

[0068] FIG. 5B is a cross-sectional view taken along line A-A of the honeycomb structural body shown in FIG. 5A.

[0069] FIG. 6A is a perspective view that schematically shows a sheet obtained from the paper-making process that forms a honeycomb structural body according to the second aspect of the present invention.

[0070] FIG. 6B is a perspective view that shows processes in which the sheets obtained from paper-making process, shown in FIG. 6A, are laminated to form a honeycomb structural body.

[0071] FIG. 7 is a cross-sectional view that schematically shows one example of an exhaust gas purifying device in which the honeycomb structural body of the second aspect of the present invention is used.

[0072] FIG. 8A is a perspective view that schematically shows another example of a honeycomb structural body according to the second aspect of the present invention.

[0073] FIG. 8B is a perspective view that schematically shows the other example of a honeycomb structural body according to the present invention.

[0074] FIG. 9 is a plan view that schematically shows a holding sealing material that is used for an exhaust gas purifying device according to a third aspect of the present invention.

[0075] FIG. 10 is an exploded perspective view that schematically shows one example of an exhaust gas purifying device according to the third aspect of the present invention.

[0076] FIG. 11 is a cross-sectional view that schematically shows one example of the exhaust gas purifying device according to the third aspect of the present invention.

[0077] FIG. 12 is an exploded perspective view that schematically shows another example of a metal shell that is

used for the exhaust gas purifying device according to the third aspect of the present invention.

[0078] FIG. 13 is a schematic drawing that shows a measuring device for coefficient of static friction.

DESCRIPTION OF THE EMBODIMENTS

[0079] First, description will be given of the honeycomb structural body according to the first aspect of the present invention.

[0080] The honeycomb structural body according to the first aspect of the present invention is a pillar-shaped honeycomb structural body made of porous ceramics and comprising a large number of through holes that are placed in parallel with one another in the length direction with a wall portion interposed therebetween, wherein the honeycomb structural body has a sealing material layer formed thereon, and the sealing material contains inorganic fibers comprising: at least about 60% and at most about 85% by weight of silica; and at least about 15% and at most about 40% by weight of at least one kind of compound selected from the group consisting of an alkali metal compound, an alkali-earth metal compound and a boron compound.

[0081] With respect to the honeycomb structural body according to the first aspect of the present invention, any structural body may be used as long as it is made of porous ceramics and comprises a large number of through holes that are placed in parallel with one another in the length direction with a wall portion interposed therebetween. Therefore, the honeycomb structural body may be a pillar-shaped porous ceramic member made of a single sintered body comprising a large number of through holes that are placed in parallel with one another in the length direction with a wall portion interposed therebetween, or may have a structure comprising a plurality of pillar-shaped porous ceramic members that are combined with one another through a sealing material layer, each of the pillar-shaped porous ceramic members including a large number of through holes that are placed in parallel with one another in the length direction with a partition wall interposed therebetween.

[0082] Therefore, in the following explanation on the honeycomb structural body according to the first aspect of the present invention, when both of the types are explained in a separate manner, the former is explained as a honeycomb structural body of a first mode and the latter is explained as that of a second mode. When it is not necessary to discriminate the two types, these are explained simply as a honeycomb structural body.

[0083] First, referring to FIG. 1A and FIG. 1B, description will be given of the honeycomb structural body of the first mode.

[0084] FIG. 1A is a perspective view that schematically shows one example of the honeycomb structural body of the first mode, and FIG. 1B is a cross-sectional view taken along line A-A of FIG. 1A.

[0085] The honeycomb structural body 10 of the first mode has a structure in which a pillar-shaped body 15 comprising a large number of through holes 11 that are placed in parallel with one another in the length direction with a wall portion 13 interposed therebetween has a sealing material layer 14 formed on the peripheral portion thereof.

The sealing material layer **14** is formed to reinforce the peripheral portion of the pillar-shaped body **15**, to adjust the shape thereof and also to improve the heat resistance of the honeycomb structural body **10**.

[0086] The sealing material layer **14** contains inorganic fibers comprising at least about 60% and at most about 85% by weight of silica and at least about 15% and at most about 40% by weight of at least one kind of compound selected from the group consisting of an alkali metal compound, an alkali-earth metal compound and a boron compound.

[0087] The above-mentioned silica is prepared as SiO or SiO₂.

[0088] Moreover, examples of the alkali metal compound include oxides of Na and K and the like, and examples of the alkali-earth metal compound include oxides of Mg, Ca and Ba and the like. Examples of the boron compound include oxides of B and the like.

[0089] The silica content of less than about 60% by weight makes it difficult to apply a glass fusing method and also to carry out a fiber-forming process. Moreover, the content in this level tends to make the structure fragile and make the inorganic fibers too easily dissolved in physiological saline.

[0090] In contrast, the silica content exceeding about 85% by weight makes the inorganic fibers difficult in dissolving in physiological saline.

[0091] Here, the content of silica was calculated based upon SiO₂ conversion.

[0092] Moreover, in the case where the content of at least one kind of compound selected from the group consisting of an alkali metal compound, an alkali-earth metal compound and a boron compound is less than about 15% by weight, the inorganic fibers tend to become difficult in dissolving in physiological saline.

[0093] In contrast, the content exceeding about 40% by weight makes it difficult to apply a glass fusing method in the production thereof and also difficult to make it into fiber form. Moreover, the content in this level makes the structure fragile and also makes the inorganic fibers too easily dissolved in physiological saline.

[0094] The solubility of the inorganic fibers in physiological saline is desirably set to about 30 ppm or more. The solubility of less than about 30 ppm makes it difficult to discharge inorganic fibers out of the human body when the inorganic fibers are taken into the human body, resulting in adverse effects on health.

[0095] The measuring method of the solubility will be described later.

[0096] The honeycomb structural body contains at least one kind of compound selected from the group consisting of an alkali metal compound, an alkali-earth metal compound and a boron compound as inorganic fibers; therefore, the ionization tendency is high, the heat resistance is high, and the solubility in physiological saline is high. For this reason, upon manufacturing, using or discarding the honeycomb structural body and the like, even if the material thereof is taken into the human body, it will be dissolved and discharged out of the human body; thus, it becomes possible to ensure safety.

[0097] Moreover, since the above-mentioned inorganic fibers are used in the honeycomb structural body, it becomes possible to provide sufficient NOx absorbing and storing effects thereto.

[0098] The reason for this is not clear, but presumably because NOx is absorbed and stored as a nitrate since the alkali metal compound, the alkali earth metal compound or the boron compound is allowed to react with NOx to generate a nitrate.

[0099] Furthermore, in the case where a catalyst is supported on the honeycomb structural body, since the above-mentioned inorganic fibers are used, it becomes possible to suppress the catalyst from being poisoned by sulfur (S), sulfur oxides (SOx) and phosphor (P), and consequently to prevent the catalyst functions from deteriorating.

[0100] The reason for this is not clear, but presumably because the alkali metal compound, the alkali earth metal compound or the boron compound is allowed to react with sulfur, sulfur oxides and phosphor in exhaust gases to generate sulfates and phosphates; thus, it becomes possible to prevent the catalyst, such as platinum, or rhodium, from reacting with sulfur, sulfur oxides and phosphor.

[0101] The lower limit of the content of the inorganic fibers in the materials is desirably set to about 10% by weight, more desirably about 20% by weight on a solid component basis. The upper limit of the content of the inorganic fibers in the materials is desirably set to about 70% by weight, more desirably about 40% by weight, further desirably about 30% by weight on a solid component basis. The content of the inorganic fibers of less than about 10% by weight tends to cause decrease of elasticity; the content thereof exceeding about 70% by weight tends to cause a reduction in thermal conductivity and degradation of effects as the elastic member.

[0102] The manufacturing method of the inorganic fibers is not particularly limited, and any of conventionally known manufacturing methods of inorganic fibers may be used. In other words, any one of methods such as a blowing method, a spinning method, and a sol-gel method may be used.

[0103] Moreover, the lower limit of the shot content of the inorganic fibers is desirably set to about 1% by weight and the upper limit thereof is desirably set to about 10% by weight, more desirably about 5% by weight, further desirably about 3% by weight. The lower limit of the fiber length is desirably set to about 0.1 μm and the upper limit thereof is desirably set to about 1000 μm , more desirably about 100 μm , further desirably about 50 μm .

[0104] Here, it is difficult to set the shot content to less than about 1% by weight in production, and the shot content exceeding about 10% by weight tends to damage the peripheral portion of the pillar-shaped body. Moreover, the fiber length of less than about 0.1 μm makes it difficult to form a honeycomb structural body having a sufficient elasticity, and the fiber length exceeding about 1000 μm tends to form a fluff ball-like structure, making it difficult to reduce the thickness of the sealing material layer. Further, when inorganic particles, which will be described later, are blended therein, the dispersing property is degraded.

[0105] In addition to the inorganic fibers, the sealing material layer may contain an inorganic binder, an organic binder, inorganic particles and the like as its materials.

[0106] Examples of the inorganic binder include silica sol, alumina sol and the like. Each of these may be used alone or two or more kinds of these may be used in combination. Among the inorganic binders, silica sol is desirably used.

[0107] The lower limit of the content of the inorganic binder in the materials is desirably set to about 1% by weight, more desirably about 5% by weight on a solid component basis. The upper limit of the content of the inorganic binder in the materials is desirably set to about 30% by weight, more desirably about 15% by weight, further desirably about 9% by weight on a solid component basis. The content of the inorganic binder of less than about 1% by weight tends to cause degradation in bonding strength; the content thereof exceeding about 30% by weight tends to cause a reduction in thermal conductivity.

[0108] Examples of the organic binder include polyvinyl alcohol, methyl cellulose, ethyl cellulose, carboxymethyl cellulose and the like. Each of these may be used alone or two or more kinds of these may be used in combination. Among the organic binders, carboxymethyl cellulose is desirably used.

[0109] The lower limit of the content of the organic binder in the materials is desirably set to about 0.1% by weight, more desirably about 0.2% by weight, further desirably about 0.4% by weight on a solid component basis. The upper limit of the content of the organic binder in the materials is desirably set to about 5.0% by weight, more desirably about 1.0% by weight, further desirably about 0.6% by weight on a solid component basis. The content of the organic binder of less than about 0.1% by weight tends to cause difficulty in suppressing migration of the sealing material layer. The content exceeding about 5.0% by weight may provide a high the rate of the organic components to a honeycomb structural body to be produced depending on the thickness of the sealing material layer, resulting in the necessity of a heating process as a post-process upon manufacturing the honeycomb structural body.

[0110] Examples of the inorganic particles may include carbides, nitrides and the like, and specific examples thereof may include inorganic powder, whiskers and the like made of silicon carbide, silicon nitride, boron nitride and the like. Each of these may be used alone, or two or more kinds of these may be used in combination. Among the inorganic fine particles, silicon carbide having superior thermal conductivity is desirably used.

[0111] The lower limit of the content of the inorganic particles in the materials is desirably set to about 3% by weight, more desirably about 10% by weight, further desirably about 20% by weight on a solid component basis. The upper limit of the content of the inorganic particles in the materials is desirably set to about 80% by weight, more desirably about 60% by weight, further desirably about 40% by weight on a solid component basis. The content of the inorganic particles of less than about 3% by weight tends to cause a reduction in thermal conductivity; the content thereof exceeding about 80% by weight tends to cause a reduction in bonding strength, when the sealing material layer is exposed to high temperatures.

[0112] The lower limit of the particle diameter of the inorganic particles is desirably set to about 0.01 μm , more desirably about 0.1 μm , and the upper limit of the particle

diameter of the inorganic particles is desirably set to about 100 μm , more desirably about 15 μm , further desirably about 10 μm . The particle diameter of less than about 0.01 μm tends to cause high costs, and the particle diameter exceeding about 100 μm tends to cause a reduction in bonding strength as well as in thermal conductivity.

[0113] Here, in the honeycomb structural body 10, the wall portion 13 separating the through holes 11 from each other is allowed to function as filters for collecting particles.

[0114] In other words, as shown in FIG. 1B, each of the through holes 11, formed in the pillar-shaped body 15 made of a single sintered body, has one of its ends on the inlet side and outlet side of exhaust gases sealed with a plug 12; thus, exhaust gases that have entered one of the through holes 11 are allowed to flow out of another through hole 11 after always passing through the wall portion 13 that separates the corresponding through holes 11.

[0115] Therefore, the honeycomb structural body 10, shown in FIG. 1A and FIG. 1B, is allowed to function as a honeycomb filter for purifying exhaust gases. When the honeycomb structural body functions as the honeycomb filter for purifying exhaust gases, all the wall portions of the through holes may be designed to function as filters for collecting particles, or only a part of the wall portions of the through holes may be designed to function as filters for collecting particles.

[0116] Moreover, in the honeycomb structural body of the first mode, the end portion of each through hole is not necessarily sealed, and in the case where the end portion of each through hole is not sealed, for example, the honeycomb structural body may be used as a catalyst supporting body on which a catalyst for converting exhaust gases can be supported.

[0117] Furthermore, the opening diameter of through holes formed in the honeycomb structural body of the first mode may be the same in all the through holes, or may be different from each other; however, it is desirable to make the opening diameter of gas flow-in cells greater than the opening diameter of gas flow-out cells with respect to all the end face. In other words, the honeycomb structural body of the first mode is desirably designed so that the opening diameters are made different from each other between the through holes with ends on one of end faces being sealed and the through holes with ends on the other end face being sealed. Since it becomes possible to accumulate a large amount of ashes on the gas flow-in cells and to effectively burn particulates, the effects of the honeycomb filter for purifying exhaust gases are easily exerted.

[0118] The modes by which the opening diameters are made different from each other between the through holes with ends on one of end faces being sealed and the through holes with ends on the other end face being sealed are not particularly limited, and, for example, those shown in FIGS. 4A to 4C may be used.

[0119] FIG. 4A shows a partially enlarged view that schematically shows one example of an end face on the gas inlet side of the honeycomb structural body of the present invention in which the opening diameters are different from each other between the through holes with ends on one of end faces being sealed and the through holes with ends on the other end face being sealed. In FIG. 4A, cross-shaped

through holes **51**, each having a large opening diameter with one of ends on the gas outlet side being sealed with a plug, are placed as gas flow-in cells, and quadrangular through holes, each having a small opening diameter with one of ends on the gas inlet side being sealed with a plug **52**, are placed as gas flow-out cells, and the respective cells are separated by the wall portion (or partition wall) **53**.

[0120] **FIG. 4B** shows a partially enlarged cross-sectional view that schematically shows another example of an end face on the gas inlet side of the honeycomb structural body of the present invention in which the opening diameters are different from each other between the through holes with ends on one of end faces being sealed and the through holes with ends on the other end face being sealed. In **FIG. 4B**, through holes **61**, each having an approximately regular octagonal shape and a large opening diameter with one of ends on the gas outlet side being sealed with a plug, are placed as gas flow-in cells, and quadrangular through holes, each having a small opening diameter with one of ends on the gas inlet side being sealed with a plug **62**, are placed as gas flow-out cells, and the respective cells are separated by the wall portion (or partition wall) **63**.

[0121] **FIG. 4C** shows a partially enlarged cross-sectional view that schematically shows still another example of an end face on the gas inlet side of the honeycomb structural body of the present invention in which the opening diameters are made different from each other between the through holes with ends on one of end faces being sealed and the through holes with ends on the other end face being sealed. In **FIG. 4C**, through holes **71**, each having an approximately regular hexagonal shape and a large opening diameter with one of ends on the gas outlet side being sealed with a plug, are placed as gas flow-in cells, and quadrangular through holes, each having a small opening diameter with one of ends on the gas inlet side being sealed with a plug **72**, are placed as gas flow-out cells, and the respective cells are separated by the wall portion (or partition wall) **73**.

[0122] Moreover, in the honeycomb structural body of the first mode, the aperture ratio on each of end faces may be the same or different from each other; however, in the case where the honeycomb structural body of the first mode is designed so that the aperture ratios on the respective end faces are made different from each other between the through holes with ends on one of end faces being sealed and the through holes with ends on the other end face being sealed, it is desirable to make the aperture ratio on the gas inlet side greater. Since it becomes possible to accumulate a large amount of ashes on the gas flow-in cells and to suppress an increase in the pressure loss, the effects of the honeycomb filter for purifying exhaust gases are easily exerted. Here, with respect to the specific shape of through holes in the case where the aperture ratios on the respective end faces are made different from each other, for example, shapes and the like as shown in the above-mentioned **FIGS. 4A** to **4C** are proposed.

[0123] Here, the shape of the honeycomb structural body of the first mode is not limited to a cylindrical shape as shown in **FIG. 1A** and **FIG. 1B**, and a pillar shape, the cross section of which is a biased flat shape such as an elliptical column shape, a rectangular pillar shape and the like may be used.

[0124] Next, description will be given of the materials and the like of the honeycomb structural body of the first mode.

[0125] The material of the pillar-shaped body made of porous ceramics is not particularly limited, and examples thereof include: nitride ceramics such as aluminum nitride, silicon nitride, boron nitride and titanium nitride; carbide ceramics such as silicon carbide, zirconium carbide, titanium carbide, tantalum carbide and tungsten carbide; and oxide ceramics such as alumina, zirconia, cordierite and mullite; and the like. Normally, oxide ceramic such as cordierite is used. These materials make it possible to carry out the manufacturing process at low costs, have a comparatively small coefficient of thermal expansion and are less susceptible to oxidation during use. Further, silicon-containing ceramics made by blending metallic silicon in the above-mentioned ceramics, and ceramics bonded by silicon and silicate compound may also be used, and for example, a ceramic material made by blending metal silicon with silicon carbide is suitably used.

[0126] In the case where the honeycomb structural body of the first mode is used as a honeycomb filter for purifying exhaust gases, the average pore diameter of the porous ceramic is desirably set in the range of about 5 to 100 μm . The average pore diameter of less than about 5 μm may cause particulates to easily clog the pores. The average pore diameter exceeding about 100 μm tends to cause particulates to pass through the pores; thus, the particulates cannot be collected, making the honeycomb structural body unable to function as a filter.

[0127] Here, the above-mentioned pore diameter can be measured through known methods such as a mercury porosimetry and a measuring method using a scanning electron microscope (SEM).

[0128] Moreover, in the case where the honeycomb structural body of the first mode is used as a honeycomb filter for purifying exhaust gases, although not particularly limited, the porosity of the porous ceramic material is desirably set in the range of about 40% to 80%. The porosity of less than about 40% may cause particulates to easily clog the pores. The porosity exceeding about 80% may deteriorate the strength of the pillar-shaped body, and the pillar-shaped body might be easily broken.

[0129] Here, the above-mentioned porosity can be measured through known methods such as a mercury porosimetry, Archimedes method, and a measuring method using a scanning electron microscope (SEM).

[0130] With respect to the particle diameter of ceramic particles to be used upon manufacturing the pillar-shaped body of this type, although not particularly limited, the diameter is desirably set so as to make the pillar-shaped body less susceptible to shrinkage in the succeeding sintering process. For example, those particles, prepared by combining 100 parts by weight of ceramic particles having an average particle diameter of about 0.3 to 50 μm with 5 to 65 parts by weight of ceramic particles having an average particle diameter of about 0.1 to 1.0 μm , are desirably used. Mixing ceramic powders having the above-mentioned respective particle diameters at the above-mentioned blending ratio enables to manufacture a pillar-shaped body made of porous ceramics.

[0131] In the case where the honeycomb structural body of the first mode has a structure in which, as shown in **FIG. 1A** and **FIG. 1B**, the ends of the through holes are sealed with

plugs, the material for the plug is not particularly limited, and the same material as that of the above-mentioned pillar-shaped body and the like may be used.

[0132] Here, the honeycomb structural body of the first mode may be used as a catalyst supporting member, and in this case, a catalyst (catalyst for converting exhaust gases) used for converting exhaust gases is supported on the honeycomb structural body.

[0133] By using the honeycomb structural body as a catalyst supporting member, toxic components such as HC, CO, NOx and the like contained in exhaust gases, and HC and the like derived from organic components slightly contained in the honeycomb structural body are positively converted.

[0134] Examples of the catalyst for converting exhaust gases are not particularly limited, and may include noble metals such as platinum, palladium and rhodium. Each of these noble metals may be used alone, or two or more kinds of these may be used in combination.

[0135] In the case where a catalyst is supported thereon in this manner, by using the inorganic fibers as described above, NOx absorbing and storing effects are applied thereto, so that it becomes possible to suppress the catalyst from being poisoned and consequently to provide an excellent exhaust gas converting function.

[0136] Here, the catalyst for converting exhaust gases made of the above-mentioned noble metal is a so-called three-way catalyst. The above-mentioned exhaust gas converting catalyst is not particularly limited to the above-mentioned noble metals, and any desired catalyst may be used as long as it can convert the toxic components, such as CO, HC and NOx, in exhaust gases. For example, in order to convert NOx in exhaust gases, an alkali metal, an alkali-earth metal and the like may be supported thereon. Moreover, a rare-earth oxide or the like may be added as a co-catalyst.

[0137] When the catalyst for converting exhaust gases is supported on the honeycomb structural body of the first mode in this manner, the toxic components, such as CO, HC and NOx, contained in exhaust gases discharged from an internal combustion system such as an engine contact with the catalyst for converting exhaust gases, so that reactions, indicated by the following reaction formulas (1) to (3), are mainly accelerated.

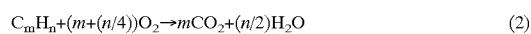

[0138] Through the above-mentioned reaction formulas (1) and (2), CO and HC, contained in exhaust gases, are oxidized to CO₂ and H₂O, and through the above-mentioned reaction formula (3), NOx contained in the exhaust gases is reduced by CO to N₂ and CO₂.

[0139] In other words, in the honeycomb structural body in which the catalyst for converting exhaust gases is supported, the toxic components such as CO, HC and NOx contained in exhaust gases are converted into CO₂, H₂O, N₂ and the like, and discharged outside.

[0140] Moreover, in the case where the catalyst for converting exhaust gases is supported in the honeycomb struc-

tural body of the first mode, the catalyst may be supported uniformly inside the through hole, or may be supported on only one area inside the through hole, or may be supported in a manner so as to have a density gradient from one of the gas inlet side and gas flow-out side toward the other side.

[0141] Furthermore, the honeycomb structural body of the first mode may have a structure in which an end portion of each through hole is sealed, with a catalyst for converting exhaust gases being supported thereon, so as to function as a honeycomb filter for purifying exhaust gases.

[0142] In this case, the catalyst for converting exhaust gases may be supported on both of the gas flow-in cell and the gas flow-out cell, or on only one of the cells. The catalyst is more desirably supported on only the gas flow-out cell since the resulting structure is allowed to effectively exert both of the functions as the honeycomb filter for purifying exhaust gases and the functions for converting exhaust gases by the use of the catalyst for converting exhaust gases.

[0143] Moreover, in the case where a catalyst is supported on the honeycomb structural body of the first mode, in order to improve the reactivity of the catalyst, the honeycomb structural body may have thin wall (0.01 to 0.2 mm) and a high density (400 to 1500 cells/square inch (62 to 233 cells/cm²)) so that the specific surface area is increased. This structure also makes it possible to improve the temperature raising property by utilizing exhaust gases.

[0144] When the reactivity of the catalyst is improved as described above, in particular, when the thickness of the partition wall is reduced, the honeycomb structural body becomes more susceptible to erosion (wind erosion) due to exhaust gases. For this reason, the strength of the end portions is desirably improved by the following methods so as to prevent erosion (improvement of erosion resistance) of the end portions on the exhaust gas inlet side (preferably, with respect to the thickness of a portion ranging from 1 to 10 mm in the end).

[0145] More specifically, the following methods and the like are proposed: a method in which the partition wall of the end portion is made about 1.1 to 2.5 times thicker than the base material; a method in which a glass layer is installed or the ratio of the glass component is made higher (erosion is prevented by allowing the glass to fuse in comparison with the base material); a method in which the pore capacity and the pore diameter are made smaller to form a dense structure (more specifically, the porosity at the end portion is made lower than the porosity of the base material except for the end portion by 3% or less or the porosity of the end portion is preferably set to 30% or less); a method in which phosphate, aluminum diphosphate, a composite oxide of silica and alkali metal, silica sol, zirconia sol, alumina sol, titania sol, cordierite powder, cordierite shard, talc, alumina or the like is added thereto and the corresponding portion is sintered to form a reinforced portion; and a method in which the catalyst layer is made thicker (1.5 times or less as thick as the base material).

[0146] Next, description will be given of a manufacturing method (hereinafter, also referred to as the first manufacturing method) for the pillar-shaped honeycomb structural body made of porous ceramics of the first mode.

[0147] First, a raw material paste is prepared by adding a binder and a dispersant solution to the above-mentioned ceramic powder.

[0148] The binder is not particularly limited, and examples thereof may include: methyl cellulose, carboxymethyl cellulose, hydroxy ethylcellulose, polyethylene glycol, phenolic resin, epoxy resin and the like.

[0149] In general, the blended amount of the above-mentioned binder is desirably set to 1 to 10 parts by weight with respect to 100 parts by weight of the ceramic powder.

[0150] The dispersant solution is not particularly limited, and examples thereof may include: anorganic solvent such as benzene; alcohol such as methanol; water and the like.

[0151] An appropriate amount of the dispersant solution is mixed so that the viscosity of the material paste is set within a fixed range.

[0152] These ceramic powder, binder and dispersant solution are mixed by an attritor or the like, and sufficiently kneaded by a kneader or the like, and then extrusion-molded so that a pillar-shaped formed body having approximately the same shape as the pillar-shaped body 15 shown in FIG. 1A and FIG. 1B is formed.

[0153] Moreover, a molding auxiliary may be added to the material paste, if necessary.

[0154] The molding auxiliary is not particularly limited, and examples thereof may include: ethylene glycol, dextrin, fatty acid soap, polyalcohol and the like.

[0155] Next, the ceramic formed body is dried by using a microwave drier or the like.

[0156] Then, if necessary, a mouth-sealing process is carried out so that predetermined through holes are filled with a plug, and the resulting formed body is again subjected to a drying process using a microwave drier or the like. The plug is not particularly limited and, for example, the same material as the above-mentioned material paste may be used.

[0157] When the mouth-sealing process is carried out in the above-mentioned process, a honeycomb structural body, which functions as a honeycomb filter for purifying exhaust gases, is manufactured through following-processes.

[0158] Next, the ceramic formed body is subjected to degreasing and firing processes under predetermined conditions so that a pillar-shaped body 15 made of porous ceramics is manufactured.

[0159] Thereafter, a sealing material layer 14 is formed on the periphery of the pillar-shaped body 15 thus manufactured.

[0160] The sealing material paste used for forming the sealing material layer is not particularly limited and, for example, the paste containing inorganic binder, organic binder and inorganic particles and the like in addition to the above-mentioned inorganic fiber can be used.

[0161] Moreover, the sealing material paste may contain a small amount of moisture, a solvent and the like, and normally, these moisture, solvent and the like are almost entirely scattered through a heating process and the like after the coating process of the sealing material paste.

[0162] In order to soften the sealing material paste and impart fluidity thereto so as to be easily applied, in addition to the above-mentioned inorganic fibers, inorganic binder, organic binder and inorganic particles, this sealing material

paste may contain moisture and another solvent such as acetone or alcohol, in the range of about 35% to 65% by weight with respect to the total weight, and the viscosity of the sealing material paste is desirably set within the range of about 45 ± 5 P·s (40000 to 50000 cps (cP)).

[0163] Next, the sealing material paste layer thus formed is dried at a temperature of about 120° C. to evaporate moisture to form a sealing material layer 14, so that a honeycomb structural body 10 having the sealing material layer 14 formed on the periphery of the pillar-shaped body 15 as shown in FIG. 1A and FIG. 1B is prepared.

[0164] The honeycomb structural body according to the first mode is manufactured through the above-mentioned processes.

[0165] Referring to FIG. 2, FIG. 3A and FIG. 3B, description will be given of the honeycomb structural body of the second mode.

[0166] FIG. 2 is a perspective view that schematically shows one example of the honeycomb structural body of the second mode.

[0167] FIG. 3A is a perspective view that schematically shows a porous ceramic member to be used for the honeycomb structural body of the second mode shown in FIG. 2, and FIG. 3B is a cross-sectional view taken along line B-B of FIG. 3A.

[0168] As shown in FIG. 2, in the honeycomb structural body 20 of the second mode, a plurality of porous ceramic members 30 are combined with one another through sealing material layer 23 to form a ceramic block 25, and a sealing material layer 24 is also formed on the peripheral portion of the ceramic block 25.

[0169] Moreover, as shown in FIG. 3A and FIG. 3B, each of the porous ceramic members 30 has a structure in which a number of through holes 31 are placed in parallel with one another in the length direction so that partition wall 33 that separates the through holes 31 from each other is allowed to function as filters for collecting particles.

[0170] In this case, with respect to the sealing material layer, the same sealing material layer as that explained in the honeycomb structural body of the first mode, that is, the sealing material layer, which contains inorganic fibers comprising at least about 60% and at most about 85% by weight of silica and at least about 15% and at most about 40% by weight of at least one kind of compound selected from the group consisting of an alkali metal compound, an alkali-earth metal compound and a boron compound, is formed.

[0171] The above-mentioned honeycomb structural body contains at least one kind of compound selected from the group consisting of an alkali metal compound, an alkali-earth metal compound and a boron compound as inorganic fibers; therefore, the ionization tendency is high, the heat resistance is high, and the solubility in physiological saline is high. Consequently, upon manufacturing, using or discarding the honeycomb structural body and the like, even if the material thereof was taken into the body, it would be dissolved and discharged out of the body; thus, it becomes possible to ensure safety.

[0172] Moreover, since the inorganic fibers are used in the honeycomb structural body, it becomes possible to provide sufficient NOx absorbing and storing effects thereto.

[0173] The reason for this is not clear, but presumably because NO_x is absorbed and stored as a nitrate since the alkali metal compound, the alkali earth metal compound or the boron compound is allowed to react with NO_x to generate a nitrate.

[0174] Furthermore, in the case where a catalyst is supported on the honeycomb structural body, since the above-mentioned inorganic fibers are used, it becomes possible to suppress the catalyst from being poisoned by sulfur (S), sulfur oxides (SO_x) and phosphor (P), and consequently to prevent the catalyst functions from deteriorating.

[0175] The reason for this is not clear, but presumably because the alkali metal compound, the alkali earth metal compound or the boron compound is allowed to react with sulfur, sulfur oxides and phosphor in exhaust gases to generate sulfates and phosphates; thus, it becomes possible to prevent the catalyst, such as platinum or rhodium, from reacting with sulfur, sulfur oxides and phosphor.

[0176] Here, the sealing material layer 24 is placed so as to prevent exhaust gases from leaking through the peripheral portion of the ceramic block 25 and to protect the ceramic block itself in the case the honeycomb structural body 20 is placed in an exhaust passage in an internal combustion engine.

[0177] Moreover, the sealing material layer 23 is placed so as to bond the porous ceramic members 30 to each other and prevent exhaust gases from leaking from porous ceramic members 30. The sealing material layer 23 is also referred to as an adhesive layer.

[0178] Therefore, the honeycomb structural body 20, shown in FIG. 2, FIG. 3A and FIG. 3B, is allowed to function as a honeycomb filter for purifying exhaust gases.

[0179] In the same manner as the honeycomb structural body of the first mode, in the honeycomb structural body of the second mode, the end portion of each through hole is not necessarily sealed, and in the case where the end portion of each through hole is not sealed, the honeycomb structural body may for example be used as a catalyst supporting body on which a catalyst for converting exhaust gases can be supported.

[0180] In the case where a catalyst is supported thereon, by using the inorganic fibers as described above, NO_x absorbing and storing effects are applied thereto, so that it becomes possible to suppress the catalyst from being poisoned and consequently to provide an excellent exhaust gas converting function.

[0181] Moreover, in the same manner as the opening diameter and the aperture ratio of through holes formed in the honeycomb structural body of the first mode, the opening diameter and the aperture ratio of through holes formed in the honeycomb structural body of the second mode may be the same in all the through holes, or may be different from each other; however, it is desirable to make the opening diameter or the aperture ratio of gas flow-in cells greater than the opening diameter or the aperture ratio of gas flow-out cells.

[0182] In other words, the honeycomb structural body of the second mode is desirably designed so that the opening diameters are made different from each other between the through holes with ends on one of end faces being sealed and

the through holes with ends on the other end face being sealed. Since it becomes possible to accumulate a large amount of ashes on the gas flow-in cells and to effectively burn particulates, the effects of the honeycomb filter for purifying exhaust gases are easily exerted.

[0183] Moreover, for the same reason as described above, the honeycomb structural body of the second mode can be designed so that the aperture ratios on the respective end faces are made different from each other between the through holes with ends on one of end faces being sealed and the through holes with ends on the other end face being sealed.

[0184] In the same manner as the honeycomb structural body of the first mode, the modes by which the opening diameters and the aperture ratios are made different from each other between the through holes with ends on one of end faces being sealed and the through holes with ends on the other end face being sealed are not particularly limited and, for example, those shown in FIGS. 4A to 4C, and the like may be used.

[0185] Moreover, the shape of the honeycomb structural body of the second mode is not limited to a cylindrical shape as shown in FIG. 2, and a pillar shape, the cross section of which has a biased flat shape such as an elliptical column shape, a rectangular pillar shape and the like may be used.

[0186] Next, description will be given of the materials and the like of the honeycomb structural body of the second mode.

[0187] The material for the porous ceramic member is not particularly limited, and examples thereof may include: nitride ceramics, carbide ceramics, oxide ceramics and the like in the same manner as the material for the pillar-shaped body as described in the honeycomb structural body of the first mode. Among these, silicon carbide, which has high heat resistance, excellent mechanical properties and a high thermal conductivity, is desirably used. Here, silicon-containing ceramics made by blending metallic silicon in the above-mentioned ceramics, and ceramics bonded by silicon and silicate compound may also be used, and for example, a ceramic material made by blending metal silicon with silicon carbide is suitably used.

[0188] Moreover, the average pore diameter and the porosity of the porous ceramic member are not particularly limited, and the same average pore diameter and porosity as those of the honeycomb structural body of the first mode are desirably employed. The particle diameter of the ceramic material to be used for manufacturing the porous ceramic member is not particularly limited, and the same particle diameter as that of the honeycomb structural body of the first mode may be employed.

[0189] Further, the honeycomb structural body of the second mode may be used as a catalyst supporting member, and in this case, a catalyst for converting exhaust gases is supported on the honeycomb structural body.

[0190] With respect to the catalyst for converting exhaust gases, the same catalyst for converting exhaust gases as used for the catalyst supporting member of the honeycomb structural body of the first mode, and the like may be used.

[0191] In the same manner as the honeycomb structural body of the first mode, the catalyst for converting exhaust

gases may be supported on the honeycomb structural body of the second mode uniformly inside the through hole, or may be supported on only one area inside the through hole, or may be supported in a manner so as to have a density gradient from one of the gas inlet side and gas flow-out side toward the other side.

[0192] Furthermore, in the same manner as the honeycomb structural body of the first mode, the honeycomb structural body of the second mode may have a structure in which an end portion of each through hole is sealed, with a catalyst for converting exhaust gases being supported thereon, so as to function as a honeycomb filter for purifying exhaust gases.

[0193] In this case, the catalyst for converting exhaust gases may be supported on both of the gas flow-in cell and the gas flow-out cell, or on only one of the cells. The catalyst is more desirably supported on only the gas flow-out cell since the resulting structure is allowed to effectively exert both of the functions as the honeycomb filter for purifying exhaust gases and the functions of converting exhaust gases.

[0194] In the case where a catalyst is supported on the honeycomb structural body of the second mode in the same manner as the honeycomb structural body of the first mode, in order to improve the reactivity of the catalyst, the honeycomb structural body may have thin wall and a high density so that the specific surface area is increased. This structure also makes it possible to improve the temperature raising property by utilizing exhaust gases.

[0195] When the reactivity of the catalyst is improved in the same manner as the honeycomb structural body of the first mode, in particular, when the thickness of the partition wall is reduced, the strength of the end portions is desirably improved so as to improve erosion resistance.

[0196] Moreover, in the honeycomb structural body of the second mode, as shown in FIG. 2, FIG. 3A and FIG. 3B, a sealing material layer is desirably formed on the peripheral portion thereof, and in this case, with respect to the material for forming the sealing material layer, the same material as that of the sealing material layer for forming the honeycomb structural body of the first mode and the like may be used.

[0197] Referring to FIG. 2, FIG. 3A and FIG. 3B, description will be given of a method (hereinafter, referred to as a second manufacturing method) for manufacturing the honeycomb structural body of the second mode in which a plurality of porous ceramic members are combined with one another through sealing material layer.

[0198] More specifically, first, a ceramic laminated body to be used for forming a ceramic block 25 is manufactured.

[0199] The ceramic laminated body has a pillar-shaped structure in which pillar-shaped porous ceramic members 30, each comprising a number of through holes 31 that are placed in parallel with one another in the length direction with a partition wall 33 interposed therebetween, are combined with one another through sealing material layer 23.

[0200] In order to manufacture a porous ceramic member 30, first, a binder and a dispersant solution are added to the above-mentioned ceramic powder to prepare a mixed composition.

[0201] The method for preparing the mixed composition is not particularly limited and, for example, the same method

as the method for preparing the material paste explained in the first manufacturing method may be used.

[0202] Next, the mixed composition is further mixed by using an attritor or the like, and after having been sufficiently mixed and kneaded by using a kneader or the like, this is molded into a pillar-shaped raw formed body having approximately the same shape as the porous ceramic member 30 shown in FIG. 3A and FIG. 3B through an extrusion-molding process or the like.

[0203] The raw formed body is dried by using a microwave drier or the like, and a mouth-sealing process is carried out thereon so that predetermined through holes are filled with plugs, and the resulting formed body is again subjected to a drying process using a microwave drier or the like.

[0204] The material of the plug is not particularly limited and, for example, the same material as the mixed composition may be used.

[0205] Next, the ceramic formed body that has been subjected to the mouth-sealing process is subjected to a degreasing process by heating it at a temperature in the range of about 300° C. to 650° C. in an oxygen-containing atmosphere so that the binder and the like are volatilized, as well as being decomposed and eliminated, to allow only the ceramic powder to remain therein.

[0206] Next, the formed body that has been degreased is fired by heating it at about 1400° C. to 2200° C. in an inert gas atmosphere such as nitrogen or argon so that the ceramics powder is sintered to produce a porous ceramic member 30.

[0207] Thereafter, sealing material paste, which is used for forming a sealing material layer 23, is applied to side faces 30a and 30b of the porous ceramic member 30 with a uniform thickness so that a paste layer is formed, and a process for successively laminating another porous ceramic member 30 on this paste layer is repeated so that a pillar-shaped ceramic laminated body having a predetermined size is formed.

[0208] Next, this ceramic laminated body is heated at a temperature of 50° C. to 100° C. for about one hour so that the paste layer is dried and solidified to form a sealing material layer 23, and the peripheral portion thereof is cut by, for example, a diamond cutter and the like into a shape as shown in FIG. 2; thus, a ceramic block 25 is manufactured.

[0209] The material for preparing the sealing material paste to form the sealing material layer 23 is not particularly limited and, for example, the same material as the sealing material paste explained in the first manufacturing method may be used.

[0210] Moreover, prior to cutting the peripheral portion of the dried ceramic laminated body, the ceramic laminated body may be cut in a direction perpendicular to the length direction, if necessary.

[0211] By using this process, the length of the honeycomb structural body to be manufactured in the length direction is set to a predetermined length, and the end faces of the honeycomb structural body are flattened, so that, in particular, the flatness of the end faces is set to about 2 mm or less.

[0212] Here, the length direction of the ceramic laminated body refers to a direction in parallel with the through holes of the porous ceramic members constituting a ceramic laminated body, and even in the case where a number of porous ceramic members are laminated and bonded in a process for forming a ceramic laminated body so that the length of a face formed by the end faces of the porous ceramic member becomes longer than the length of the side face thereof, the direction in parallel with the side face of the porous ceramic member is referred to as the length direction of the ceramic laminated body.

[0213] The method for cutting the ceramic laminated body in a direction perpendicular to the length direction thereof is not particularly limited and, for example, a method in which the ceramic laminated body is cut perpendicularly to the length direction of the ceramic laminated body at a portion in which all the porous ceramic members are laminated in the vicinity of an end face of the ceramic laminated body by using a diamond cutter or the like may be used.

[0214] Next, a sealing material layer 24 is formed on the periphery of the ceramic block 25 thus manufactured. Thus, a honeycomb structural body in which a plurality of porous ceramic members are combined with one another through sealing material layer is formed.

[0215] The method for forming the sealing material layer is not particularly limited, and the same method as the method explained in the manufacturing method for the honeycomb structural body of the first mode may be used.

[0216] By using the above-mentioned processes, a honeycomb structural body according to the second mode is manufactured.

[0217] Here, each of the honeycomb structural bodies thus produced by using the first and second manufacturing methods may be used as a catalyst supporting member for a catalyst for converting exhaust gases. In other words, in the case where the honeycomb structural body of the present invention is used as the catalyst supporting member, a catalyst for converting exhaust gases is supported thereon so that the honeycomb structural body of the present invention is allowed to exert functions for converting toxic components such as HC, CO and NO_x contained in exhaust gases, and gases derived from organic components slightly contained in the honeycomb structural body.

[0218] Moreover, in the case where a catalyst for converting exhaust gases is applied to the inside of the through holes with one of ends of each through hole being sealed, the honeycomb structural body of the present invention is allowed to function as a particle collecting filter for collecting particulates in exhaust gases, and also to have a function of converting toxic components such as HC, CO and NO_x in exhaust gases and gases generated from organic components slightly contained in the honeycomb structural body of the present invention.

[0219] Next, description will be given of the honeycomb structural body according to the second aspect of the present invention.

[0220] The honeycomb structural body according to the second aspect of the present invention is a pillar-shaped honeycomb structural body mainly made of inorganic fibers and comprising a plurality of through holes that are placed

in parallel with one another in the length direction with a wall portion interposed therebetween, wherein the inorganic fibers comprise at least about 60% and at most about 85% by weight of silica and at least about 15% and at most about 40% by weight of at least one kind of compound selected from the group consisting of an alkali metal compound, an alkali-earth metal compound and a boron compound.

[0221] The above-mentioned honeycomb structural body contains at least one kind of compound selected from the group consisting of an alkali metal compound, an alkali-earth metal compound and a boron compound as inorganic fibers; therefore, the ionization tendency is high, the heat resistance is high, and the solubility in physiological saline is high. Consequently, upon manufacturing, using or discarding the honeycomb structural body and the like, even if the material thereof is taken into the body, it will be dissolved and discharged out of the body; thus, it becomes possible to ensure safety.

[0222] Moreover, since the above-mentioned inorganic fibers are used in the honeycomb structural body, it becomes possible to provide sufficient NO_x absorbing and storing effects thereto.

[0223] The reason for this is not clear, but presumably because NO_x is absorbed and stored as a nitrate since the alkali metal compound, the alkali earth metal compound or the boron compound is allowed to react with NO_x to generate a nitrate.

[0224] Furthermore, in the case where a catalyst is supported on the honeycomb structural body, since the above-mentioned inorganic fibers are used, it becomes possible to suppress the catalyst from being poisoned by sulfur (S), sulfur oxides (SO_x) and phosphor (P), and consequently to prevent the catalyst functions from deteriorating.

[0225] The reason for this is not clear, but presumably because the alkali metal compound, the alkali earth metal compound or the boron compound is allowed to react with sulfur, sulfur oxides and phosphor in exhaust gases to generate sulfates and phosphates; thus, it becomes possible to prevent the catalyst, such as platinum or rhodium, from reacting with sulfur, sulfur oxides and phosphor.

[0226] The honeycomb structural body according to the second aspect of the present invention is mainly made of inorganic fibers, and the inorganic fibers comprise at least about 60% and at most about 85% by weight of silica and at least about 15% and at most about 40% by weight of at least one kind of compound selected from the group consisting of an alkali metal compound, an alkali-earth metal compound and a boron compound.

[0227] Specific examples of the above-mentioned silica, alkali metal compound, alkali earth metal compound and boron compound are the same as those used in the first aspect of the present invention.

[0228] With respect to the average fiber length of the inorganic fibers, a desirable lower limit value is set to about 0.1 mm and a desirable upper limit value is set to about 100 mm, more desirably, the lower limit value is set to about 0.5 mm and the upper limit value is set to about 50 mm.

[0229] With respect to the average fiber diameter of the inorganic fibers, a desirable lower limit value is set to about 1 μm, and a desirable upper limit value thereof is set to about

30 μm , more desirably, the lower limit value is set to about 2 μm and the upper limit value is set to about 10 μm .

[0230] In addition to the above-mentioned inorganic fibers, the honeycomb structural body may contain a binder used for combining the inorganic fibers with one another so as to maintain a predetermined shape.

[0231] The above-mentioned binder is not particularly limited and inorganic glass such as silicate glass, silicate alkali glass or borosilicate glass, alumina sol, silica sol, titania sol and the like may be used.

[0232] In the case where the binder is contained, a desirable lower limit of the content is set to about 5% by weight and a desirable upper limit of the content is set to about 50% by weight; more desirably, the lower limit value is set to about 10% by weight and the upper limit value is set to about 40% by weight.

[0233] With respect to the apparent density of the honeycomb structural body, a desirable lower limit value is set to about 0.05 g/cm^3 and a desirable upper limit value is set to about 1.00 g/cm^3 ; more desirably, the lower limit value is set to about 0.10 g/cm^3 and the upper limit value is set to about 0.50 g/cm^3 .

[0234] With respect to the porosity of the honeycomb structural body, a desirable lower limit value is set to about 60% by capacity and a desirable upper limit value is set to about 98% by capacity; more desirably, the lower limit value is set to about 80% by capacity and the upper limit value is set to about 95% by capacity.

[0235] Here, the apparent density and porosity can be measured through known methods, such as a weighing method, Archimedes method, and a measuring method using a scanning electron microscope (SEM).

[0236] On the inorganic fibers forming the honeycomb structural body of the present invention, a catalyst comprising a noble metal, such as platinum, palladium or rhodium, may be supported. In addition to the noble metals, an element such as an alkali metal (Group 1 in Element Periodic Table), an alkali earth metal (Group 2 in Element Periodic Table), a rare-earth element (Group 3 in Element Periodic Table) and a transition metal element may be added thereto.

[0237] When such a catalyst is supported thereon, the filter using the honeycomb structural body of the present invention is allowed to function as a filter capable of collecting particulates in exhaust gases and regenerating the filter by the catalyst, and also to function as a catalyst converter for converting CO, HC, NO_x and the like contained in exhaust gases.

[0238] The honeycomb structural body of the present invention in which the above-mentioned catalyst comprising the noble metal is supported is allowed to function as a gas converting device in the same manner as the conventionally known DPFs (Diesel Particulate Filters) with catalyst. Therefore, the detailed explanation of the case in which the honeycomb structural body of the present invention also serves as a catalyst converter is omitted.

[0239] The honeycomb structural body may contain a slight amount of inorganic particles and metal particles. Examples of the inorganic particles may include carbides,

nitrides, oxides and the like. Specific examples thereof may include inorganic powder made of silicon carbide, silicon nitride, boron nitride, alumina, silica, zirconia, titania or the like, and the like. Examples of the metal particles may include metallic silicon, aluminum, iron, titanium and the like. Each of these may be used alone, or two or more kinds of these may be used in combination.

[0240] Next, referring to the drawings, description will be given of embodiments of a honeycomb structural body according to the second aspect of the present invention.

[0241] FIG. 5A is a perspective view that schematically shows a specific example of the honeycomb structural body of the second aspect of the present invention, and FIG. 5B is across-sectional view taken along line A-A of FIG. 5A.

[0242] As shown in FIG. 5A and FIG. 5B, the honeycomb structural body according to the second aspect of the present invention is prepared as a laminated body formed by laminating sheet-shaped members 110a with a thickness of about 0.1 to 20 mm in the length direction, and the sheet-shaped members 110a are laminated so that the through holes 111 are superposed on one another in the length direction.

[0243] Here, the expression, "the through holes are superposed on one another" refers to the fact that the sheet-shaped members are laminated so that the corresponding through holes formed in adjacent sheet-shaped members are allowed to communicate with each other.

[0244] The sheet-shaped members are easily obtained through a paper-making method and the like, and by laminating them, a honeycomb structural body made of a laminated body is prepared. The laminated body may be formed by bonding the members using an inorganic adhesive or the like, or may be formed by simply laminating the members physically.

[0245] Upon manufacturing the laminated body, the sheet-shaped members are directly laminated in a casing (a cylindrical member made of metal) to be attached to an exhaust pipe, and a pressure is applied thereto so that a honeycomb structural body is formed. The forming method and laminating method for the sheet-shaped members, and the like will be described later.

[0246] A honeycomb structural body 110 has a cylindrical structure in which a large number of bottomed holes 111, with one of ends of through holes being sealed, are placed in parallel with one another in the length direction with a wall portion 113 interposed therebetween so that the honeycomb structural body functions as a filter.

[0247] In other words, as shown in FIG. 5B, each of the bottomed holes 111 is sealed at one of ends of its exhaust gas inlet side and outlet side so that exhaust gases that have entered one bottomed hole 111 are discharged from another bottomed hole 111 after having always passed through the partition wall 113 that separates the bottomed holes 111; thus, the honeycomb structural body is allowed to function as a filter.

[0248] With respect to the thickness of the wall portion, a desirable lower limit value is set to about 0.2 mm and a desirable upper limit value is set to about 10.0 mm; more desirably, the lower limit value is set to about 0.3 mm and the upper limit value is set to about 6.0 mm.

[0249] With respect to the density of through holes on a cross section perpendicular to the length direction of the honeycomb structural body, a desirable lower limit value is set to about 0.16 piece/cm² (1.0 piece/in²) and a desirable upper limit value is set to about 62 pcs/cm² (400 pcs/in²); more desirably, the lower limit value is set to about 0.62 piece/cm² (4.0 pcs/in²) and the upper limit value is set to about 31 pcs/cm² (200 pcs/in²).

[0250] Here, the size of the through hole is desirably set in the range of about 1.4 mm×about 1.4 mm to about 16 mm×about 16 mm.

[0251] The honeycomb structural body **110** shown in **FIG. 5A** and **FIG. 5B** has a cylindrical shape; however, the shape is not particularly limited to the cylindrical shape, and the honeycomb structural body according to the second aspect of the present invention may have any desired pillar shape, such as an elliptical column shape or a rectangular pillar shape, and any size.

[0252] Moreover, in the case where the filter is installed right under the engine, the filter space is extremely limited, and a complex filter shape is required; however, in the case of the present invention, even a complex shape, such as the shape of a filter **130** with a concave portion on one side as shown in **FIG. 8A** or the shape of a filter **140** with concave portions on two sides as shown in **FIG. 8B**, can be easily formed by superposing sheets **130a** or **140a** obtained from paper-making process in the length direction. Moreover, since the sheets **130a** or **140a** obtained from paper-making process are superposed in the length direction, even a curved shape in the length direction and a deformed shape that is gradually changed in the length direction can be easily formed.

[0253] The regenerating process of a filter using the honeycomb structural body corresponds to a burning process for collected particulates. With respect to the regenerating method for the honeycomb structural body of the present invention, a method in which the honeycomb structural body is heated by a heating means installed on the exhaust gas inlet side may be used, or a method in which an oxidizing catalyst is supported on the honeycomb structural body so that heat, generated by oxidation of hydrocarbon or the like in exhaust gases due to the oxidizing catalyst, is utilized to carry out the regenerating process in parallel with the converting process for exhaust gases may be used. Moreover, another method in which a catalyst that directly oxidizes solid-state particulates is placed on the filter, or still another method in which an oxidizing catalyst, placed on the upstream side of the filter, is used to generate NO₂ by oxidizing NO_x so that the particulates are oxidized by using the resulting NO₂, may be used.

[0254] Referring to **FIG. 6A** and **FIG. 6B**, description will be given of a manufacturing method for a honeycomb structural body according to the second aspect of the present invention.

[0255] (1) Catalyst Applying Process to Inorganic Fibers

[0256] Inorganic fibers (the same inorganic fibers as those forming the sealing material layer of the honeycomb structural body according to the first aspect of the present invention), which contain at least about 60% and at most about 85% by weight of silica and at least about 15% and at most about 40% by weight of at least one kind of compound

selected from the group consisting of an alkali metal compound, an alkali-earth metal compound and a boron compound, are impregnated with a slurry of an oxide on which a catalyst comprising a noble metal such as Pt is supported, and then raised from the slurry and heated to prepare inorganic fibers to which the catalyst is adhered. Here, inorganic fibers may be impregnated with a slurry containing a catalyst, and raised and heated so that the catalyst may be directly adhered to the inorganic fibers. The amount of the supported catalyst is desirably set in the range of about 0.01 to 1 g/10 g of inorganic fibers. When the honeycomb structural body having no catalyst supported thereon is manufactured, this process is omitted.

[0257] In this manner, in the honeycomb structural body according to the second aspect of the present invention, since a catalyst is adhered to the inorganic fibers serving as a constituent material prior to forming the honeycomb structural body, the catalyst can be adhered to the honeycomb structural body in a manner so as to be dispersed more uniformly. Consequently, the resulting honeycomb structural body makes it possible to improve the burning function of particulates and the converting function for toxic gases. Here, the catalyst applying process may be carried out after sheets are obtained from paper-making process.

[0258] (2) Preparation Process for Slurry for Paper-Making

[0259] Next, the inorganic fibers bearing the catalyst, obtained from the step (1), are dispersed in water (1 L) at a ratio of 5 to 100 g, and in addition to these, 10 to 40 parts by weight of an inorganic binder such as silica sol or the like, and 1 to 10 parts by weight of an organic binder such as an acrylic latex or the like are added to 100 parts by weight of the inorganic fibers, and to this, a slight amount of a coagulant such as aluminum sulfate or the like and an aggregation agent such as polyacrylic amide or the like are further added, if necessary, and sufficiently stirred to prepare a slurry for paper-making.

[0260] Examples of the organic binder may include methyl cellulose, carboxymethyl cellulose, hydroxyethyl cellulose, polyethylene glycol, phenolic resin, epoxy resin, polyvinyl alcohol, styrene butadiene rubber and the like.

[0261] (3) Paper-Making Process

[0262] The slurry, obtained in the step (2), was subjected to a paper-making process by using a perforated mesh in which holes having a predetermined shape are formed with mutually predetermined intervals, and the resulting matter was dried at a temperature of about 100° C. to 200° C. so that sheets **111a** obtained from paper-making process as shown in **FIG. 6A** having a predetermined thickness are obtained. The thickness of each sheet **110a** obtained from the paper-making process is desirably set in the range of about 0.1 to 20 mm.

[0263] In the present invention, by using, for example, a mesh with holes having a predetermined shape in a checked pattern, it is possible to obtain sheets **10b** from paper-making process to be used at two ends. In other words, by using some of these sheets obtained from paper-making process at the two ends, it is possible to obtain a honeycomb structural body functioning as a filter without the necessity of sealing predetermined through holes at the two ends after forming the through holes.

[0264] (4) Laminating Process

[0265] By using a cylindrical casing **123** having a pressing member on one side as shown in **FIG. 6B**, several sheets **110b** obtained from paper-making process for both end portions are laminated inside the casing **123**, and a plurality of sheets **110a** obtained from paper-making process for inside are then laminated therein. Then, several sheets **110b** obtained from paper-making process for both end portions are lastly laminated, and after having been pressed, another pressing member is also put on the other side and secured thereon so that a honeycomb structural body that has been subjected to a canning process is prepared. In this process, the sheets **110a**, **110b** obtained from paper-making process are laminated so that the through holes are superposed on one another.

[0266] The application of the honeycomb structural body according to the second aspect of the present invention is not particularly limited, but it is desirably used for exhaust gas purifying devices for use in vehicles.

[0267] **FIG. 7** is a cross-sectional view that schematically shows one example of an exhaust gas purifying device for use in vehicles, which is provided with the honeycomb structural body according to the second aspect of the present invention.

[0268] As shown in **FIG. 7**, an exhaust gas purifying device **210** is mainly constituted by the honeycomb structural body **220** according to the second aspect of the present invention and a casing **223** that covers the external portion of the honeycomb structural body **220**; and an introducing pipe **224** that is connected to an internal combustion system such as an engine is connected to the end of the casing **223** on the side to which exhaust gases are directed, and an exhaust pipe **225** joined to the outside is connected to the other end of the casing **223**. Here, in **FIG. 7**, arrows indicate flows of exhaust gases.

[0269] In the exhaust gas purifying device **210** having the above-mentioned arrangement, exhaust gases, discharged from the internal combustion system such as an engine, are directed into the casing **223** through the introducing pipe **224**, and allowed to flow into the through hole of the honeycomb structural body **220** and pass through the wall portion (partition wall); thus, the exhaust gases are purified, with particulates thereof being collected in the wall portion (partition wall), and are then discharged outside through the exhaust pipe **225**.

[0270] After a large quantity of particulates have been accumulated on the wall portion (partition wall) of the honeycomb structural body **220** to cause an increase in pressure loss, the honeycomb structural body **220** is subjected to a regenerating process by using the above-mentioned means.

[0271] In the case where the honeycomb structural body according to the second aspect of the present invention is formed by simply laminating sheets obtained from paper-making process physically in this manner, even if a certain degree of temperature distribution occurs in the honeycomb structural body when installed in an exhaust passage, a temperature distribution per one sheet is comparatively small, so that the sheets are less susceptible to cracks and the like.

[0272] Moreover, in the case where, in the paper-making process, the inorganic fibers are aligned approximately in parallel with the main face of the sheets obtained from paper-making process. Upon forming the laminated body, more inorganic fibers are aligned along a face perpendicular to the forming direction of the through holes in comparison with those aligned on a face in parallel with the forming direction of the through holes. Consequently, exhaust gases are allowed to more easily pass through the wall portion of the honeycomb structural body; thus, it becomes possible to reduce the initial pressure loss, and also to filtrate particulates at deeper layers inside the wall portion. Therefore, it is possible to prevent formation of cake layers on the surface of the partition wall, and consequently to suppress an increase in the pressure loss upon collecting particulates.

[0273] Moreover, since the rate of exhaust gases flowing in parallel with the aligned direction of the inorganic fibers increases, the chance of the particulates coming into contact with the catalyst adhered to the inorganic fibers increases, making it possible to easily burn the particulates.

[0274] Furthermore, in the case where sheets obtained from paper-making process, which have different dimensions of the holes, are formed and laminated, the bottomed holes are allowed to form irregularities; thus, bottomed holes having a larger surface area can be formed. Therefore, the filtering area is increased, making it possible to reduce a pressure loss upon collecting particulates. The shape of the holes is not particularly limited to a square and a quadrangular shape, and any shape, such as a triangle, a hexagon, an octagon, a dodecagon, a round shape and an elliptical shape, may be used.

[0275] Next, description will be given of the exhaust gas purifying device according to the third aspect of the present invention.

[0276] The exhaust gas purifying device according to the third aspect of the present invention is an exhaust gas purifying device comprising: a honeycomb structural body; a cylindrical metal shell that covers a periphery of the honeycomb structural body in the length direction; and a holding sealing material placed between the honeycomb structural body and the metal shell, wherein the holding sealing material mainly includes inorganic fibers comprising at least about 60% and at most about 85% by weight of silica and at least about 15% and at most about 40% by weight of at least one kind of compound selected from the group consisting of an alkali metal compound, an alkali-earth metal compound and a boron compound.

[0277] The exhaust gas purifying device contains at least one kind of compound selected from the group consisting of an alkali metal compound, an alkali-earth metal compound and a boron compound as inorganic fibers; therefore, the ionization tendency is high, the heat resistance is high, and the solubility in physiological saline is high. For this reason, upon manufacturing, using or discarding the honeycomb structural body and the like, even if the material thereof is taken into the body, it will be dissolved and discharged out of the body; thus, it becomes possible to ensure safety.

[0278] Moreover, since the above-mentioned inorganic fibers are used in the honeycomb exhaust gas purifying device, it becomes possible to provide sufficient NOx absorbing and storing effects thereto. The reason for this is

not clear, but presumably because NO_x is absorbed and stored as a nitrate since the alkali metal compound, the alkali earth metal compound or the boron compound is allowed to react with NO_x to generate a nitrate.

[0279] Furthermore, in the case where a catalyst is supported on the exhaust gas purifying device, since the above-mentioned inorganic fibers are used, it becomes possible to suppress the catalyst from being poisoned by sulfur (S), sulfur oxides (SO_x) and phosphor (P), and consequently to prevent the catalyst functions from deteriorating.

[0280] The reason for this is not clear, but presumably because the alkali metal compound, the alkali earth metal compound or the boron compound is allowed to react with sulfur, sulfur oxides and phosphor in exhaust gases to generate sulfates and phosphates; thus, it becomes possible to prevent the catalyst, such as platinum or rhodium, from reacting with sulfur, sulfur oxides and phosphor.

[0281] Referring to the drawings, description will be given of the exhaust gas purifying device according to the third aspect of the present invention.

[0282] FIG. 9 is a plan view that schematically shows a holding sealing material that is used for the exhaust gas purifying device according to the third aspect of the present invention.

[0283] FIG. 10 is an exploded perspective view that schematically shows one example of the exhaust gas purifying device according to the third aspect of the present invention.

[0284] FIG. 11 is a cross-sectional view that schematically shows one example of the exhaust gas purifying device of the present invention.

[0285] As shown in FIG. 11, the exhaust gas purifying device 300 according to the third aspect of the present invention is mainly constituted by a cylindrical honeycomb structural body 320, a cylindrical metal shell 330 that covers the peripheral portion of the honeycomb structural body 320 in the length direction, and a holding sealing material 310 that is placed between the honeycomb structural body 320 and the metal shell 330, and an introducing pipe that is connected to an internal combustion system such as an engine is connected to the end of the metal shell 330 on the side to which exhaust gases are directed, and an exhaust pipe joined to the outside is connected to the other end of the metal shell 330. Here, in FIG. 11, arrows indicate flows of exhaust gases.

[0286] The honeycomb structural body 320 is made of a porous ceramic member in which a number of through holes 321 are placed in parallel with one another in the length direction, and each of the through holes 321 has one of its ends on the inlet-side and outlet-side of exhaust gases sealed with plugs 322; thus, exhaust gases that have entered one of the through holes 321 are allowed to flow out of another through hole 321 after always passing through the partition wall 323 that separates the corresponding through holes 321. The honeycomb structural body 320, which has through holes 321 each of which has one of its ends on the inlet side and outlet side of exhaust gases sealed with plugs 322, is allowed to function as a diesel particulate filter (DPF) that collects particulates in exhaust gases.

[0287] Here, the honeycomb structural body to be used in the exhaust gas purifying device according to the third aspect of the present invention may function as a catalyst converter, and in this case, although a catalyst capable of converting CO, HC, NO_x and the like in exhaust gases needs to be supported thereon, only the through holes without sealed ends may be simply used. Moreover, by supporting a catalyst capable of converting CO, HC, NO_x and the like in exhaust gases on the honeycomb structural body 320 having through holes 321 each of which has one of its ends on the inlet side and outlet side of exhaust gases sealed with plugs 322, the honeycomb structural body 320 is allowed to function as a filter capable of collecting particulates in exhaust gases, and also to function as a catalyst converter for converting CO, HC, NO_x and the like contained in exhaust gases.

[0288] The cross-sectional shape of the honeycomb structural body 320 shown in FIG. 11 is around shape; in the exhaust gas purifying device according to the third aspect of the present invention, however, the cross-sectional shape of the honeycomb structural body is not particularly limited to the round shape, and may have any shape, such as an elliptical shape, an elongated round shape, and a polygonal shape. In this case, the cross-sectional shape of the metal shell is desirably changed depending on the cross-sectional shape of the honeycomb structural body.

[0289] Moreover, the honeycomb structural body 320 may have an integrally molded structure, or a structure in which a plurality of porous ceramic members are combined with one another through adhesive layers.

[0290] Furthermore, a sealing material layer may be formed on the peripheral portion of the honeycomb structural body 320 so as to prevent exhaust gases from leaking through the peripheral portion.

[0291] As shown in FIGS. 9 and 10, the holding sealing material 310 has a structure in which convex portion 312 is formed on one of short sides of a base material 311 having approximately a rectangular shape, with concave portion 313 being formed on the other short side so that, when the holding sealing material 310 is wound around the peripheral portion of the honeycomb structural body 320, the convex portion 312 and the concave portion 313 just fit to each other; thus, it becomes possible to wind the holding sealing material 310 around the peripheral portion of the honeycomb structural body 320 accurately without any deviations.

[0292] Here, the shape of the holding sealing material 310 is not particularly limited as long as it is formed into a mat shape, and, for example, the holding sealing material having a plurality of convex portions and concave portions may be used; alternatively, the holding sealing material having none of convex portions and concave portions may be used. Moreover, with respect to the combinations of the shapes of the convex portion 312 and the concave portion 313, in addition to a combination of a rectangular shape as shown in FIG. 9, a combination of triangles and a combination of semi-circular shapes may be employed.

[0293] The holding sealing material 310, which has been wound around the peripheral face of the pillar-shaped honeycomb structural body 320, is housed into the cylindrical metal shell 330 to constitute the exhaust gas purifying device 300. When housed into the metal shell 330, the

holding sealing material **310** is compressed in the thickness direction; thus, a repulsion (surface pressure), which resists against the compression power, is generated and the honeycomb structural body **320** is secured in the metal shell **330** through this repulsion.

[0294] Next, description will be given of constituent members of the exhaust gas purifying device according to the third aspect of the present invention.

[0295] The holding sealing material is mainly composed of inorganic fibers.

[0296] Specific examples of the inorganic fibers are the same as those used for forming the sealing material layer of the honeycomb structural body according to the first aspect of the present invention.

[0297] With respect to the fiber tensile strength of the inorganic fibers, a desirable lower limit thereof is about 1.2 GPa, and a desirable upper limit thereof is about 200 GPa. The fiber tensile strength of less than about 1.2 GPa makes the inorganic fibers fragile to a tensile force and a bending force; thus, they might be broken easily; the fiber tensile strength exceeding about 200 GPa causes an insufficient cushion property. The lower limit is more desirably set to about 1.5 GPa, and the upper limit is more desirably set to about 150 GPa.

[0298] With respect to the average fiber length of the inorganic fibers, a desirable lower limit value is set to about 0.5 mm and a desirable upper limit value is set to about 100 mm. The average fiber length of less than about 0.5 mm tends to cause fibers to be inhaled in the respiratory system. Moreover, the fibers are no longer allowed to exert features as fibers; thus, a suitable tangle of fibers no longer takes place, failing to provide a sufficient surface pressure. The average fiber length exceeding about 100 mm tends to make the tangle of fibers too strong, and the fibers tend to aggregate unevenly when they are formed into a mat-shaped formed body; thus, the dispersion in the surface pressure value may be come too large. The lower limit of the average fiber length of the inorganic fibers is more desirably set to about 10 mm, and the upper limit thereof is more desirably set to about 40 mm.

[0299] With respect to the average fiber diameter of the inorganic fibers, a desirable lower limit value is set to about 0.3 μm and a desirable upper limit value is set to about 25 μm . The average fiber diameter of less than about 0.3 μm tends to make the strength of the fibers too low, failing to provide a sufficient surface pressure, and also tends to cause fibers to be inhaled in the respiratory system. The average fiber diameter exceeding about 25 μm tends to cause a reduction in the gas permeability resistance when they are formed into a mat-shaped formed body; thus, the sealing property deteriorates and the breaking strength is lowered due to an increase in the number of small defects caused by an increase in the fiber surface area. The lower limit value of the average fiber diameter of the inorganic fibers is more desirably set to about 0.5 μm , and the upper limit value thereof is more desirably set to about 15 μm .

[0300] The dispersion in the fiber diameter of the inorganic fibers is desirably set within $\pm 3 \mu\text{m}$ with respect to the average fiber diameter. The dispersion in the fiber diameter exceeding $\pm 3 \mu\text{m}$ tends to cause unevenly accumulated fibers, making the dispersion in the surface pressure value

too high. The dispersion in the fiber diameter of the organic fibers is more desirably set within $\pm 2 \mu\text{m}$.

[0301] The shot content of the inorganic fibers is desirably set to about 50% by weight or less. The shot content exceeding about 50% by weight tends to cause the dispersion in the surface pressure value to become too high. More desirably, the shot content is set to about 30% by weight or less. Particularly desirably, the shot content is set to 0% by weight; that is, the inorganic fibers contain no shots.

[0302] In addition to a round shape, the cross-sectional shape of the inorganic fibers may have a shape such as an elliptical shape, an elongated round shape, an approximately triangular shape, and a rectangular shape.

[0303] Moreover, the holding sealing material may contain an organic binder, if necessary.

[0304] Examples of the organic binder may include a styrene-butadiene resin, an acrylonitrile-butadiene resin and the like.

[0305] Each of the organic binders may be used alone, or two or more kinds of these may be used in combination.

[0306] The styrene-butadiene resin is obtained by copolymerizing styrene monomer, butadiene monomer and the like. Moreover, the acrylonitrile-butadiene resin is obtained by copolymerizing acrylonitrile monomer, butadiene monomer and the like.

[0307] The above-mentioned organic binder desirably has a coat-film strength of about 5 MPa or more at normal temperature, and the lower limit value of the coat-film strength is more desirably set to about 10 MPa.

[0308] By using an organic binder having a coat-film strength of about 5 MPa or more at normal temperature, the exhaust gas purifying device is allowed to have an improved coefficient of friction between the surface of a holding sealing material and the surface of a metal shell, so that the honeycomb structural body is firmly secured in the metal shell from a starting stage of its use. This is presumably because, since the organic binder has a higher coat-film strength in comparison with a conventional organic binder, and is less susceptible to rupturing and extension by an externally applied force, the strength of portions bonded through the organic binder is improved, so that the bonding strength between the inorganic fibers and the metal shell, the bonding strength between the mutual inorganic fibers and the bonding strength between the inorganic fibers and the honeycomb structural body are improved.

[0309] The coat-film strength is given as a tensile breaking strength measured through the following processes in which a dumbbell shaped test sample having a thickness of 0.4 mm, made from an organic binder, is subjected to a tension test using an instron-type tension tester at a rate of 300 mm/min.

[0310] Here, the test sample is manufactured by using the following processes: latex that is a raw material for an organic binder is poured onto a glass plate with a frame, left at room temperature and dried to form a coated film.

[0311] The decomposing temperature of the organic binder is desirably set to about 200° C. or more. The decomposing temperature of less than about 200° C. causes the organic binder to be burned and eliminated at an early stage of use of the exhaust gas purifying device in which the

holding sealing material **310** is used; thus, the effect of the present invention, that is, the firmly secured state of the honeycomb structural body **320** in the metal shell **330** is not obtained sufficiently during the use of the exhaust gas purifying device.

[0312] Here, in the case where an exhaust gas purifying device using the holding sealing material **310** is heated to a temperature of about 200° C. or more, since the coefficient of friction on the metal shell **330** side is improved by oxidation and the like of the metal shell **330**, it becomes possible to firmly secure the honeycomb structural body **320** in the metal shell **330** even when the organic binder has been burned and eliminated.

[0313] With respect to the content of the organic binder, a desirable upper limit value is set to about 10% by weight. The value exceeding about 10% by weight tends to cause a failure in sufficiently reducing the total amount of decomposed gas of the organic binder generated during the use at high temperatures. The upper limit of the content of the organic binder to the entire holding sealing material of the organic binder is desirably set to about 5% by weight, more desirably about 1% by weight.

[0314] Additionally, even when its content is set to about 1% by weight or less, the organic binder makes it possible to improve the coefficient of friction with respect to the metal shell.

[0315] With respect to the thickness of the holding sealing material prior to the state where it is housed in the metal shell, a desirable lower limit value thereof is set to about 1.01 times the gap formed by the outer diameter of the honeycomb structural body and the inner diameter of the metal shell, and a desirable upper limit value thereof is set to about 4.0 times the gap thereof. The thickness of the holding sealing material of less than about 1.01 times tends to cause a displacement and a rattling of the honeycomb structural body with respect to the metal shell. In this case, since it is not possible to obtain a superior gas sealing property, exhaust gases tend to leak from the gap portion, resulting in an insufficient gas purifying operation. The thickness of the holding sealing material exceeding about 4.0 times the gap thereof tends to cause a difficulty in housing the honeycomb structural body in the metal shell in the case where, in particular, a press-in system is used upon housing the honeycomb structural body in the metal shell. The lower limit of the thickness of the holding sealing material is more desirably set to about 1.5 times the gap, and the upper limit of the thickness of the holding sealing material is more desirably set to about 3.0 times the gap thereof.

[0316] The lower limit of coefficient of static friction of the holding sealing material to the metal shell is desirably set to about 0.20. The coefficient of less than about 0.20 tends to fail to firmly secure the honeycomb structural body in the metal shell.

[0317] Here, the coefficient of static friction can be measured by using a measuring device as shown in FIG. 13. More specifically, an SUS plate **401**, a holding sealing material **410** having a size of 30 mm×50 mm and a weight **402** of 5 kg were placed in succession on a hot plate **400** at normal temperature, and after this state has been maintained for 10 minutes, a wire **403** to which the weight **402** is

attached is pulled at a rate of 10 mm/min through a pulley **404** by using a universal testing machine **405**, and the peak load F is measured. Here, a protrusion or the like is formed in the weight **402** so as not to cause a displacement on an interface between the weight **402** and the holding sealing material **410** so that the two members are firmly secured so as to carry out the measurements. Based upon the resulting peak load $F(N)$ and a force $N(N)$ exerted in a perpendicular direction on the contact face between the SUS plate **401** and the holding sealing material **410**, the coefficient of static friction μ is calculated from the following relational expression (4).

$$\mu = F/N \quad (4)$$

[0318] With respect to the gap bulk density (GBD) in a state in which the holding sealing material is housed in the metal shell, a desirable lower limit value is set to about 0.20 g/cm³, and a desirable upper limit value is set to about 0.60 g/cm³. When the GBD is less than about 0.20 g/cm³, it is not possible to obtain a sufficiently high initial surface pressure to cause a failure in obtaining a firmly secured state of the honeycomb structural body in the metal shell during use of the exhaust gas purifying device, due to a reduction in surface pressure with elapsed time. In contrast, the GBD exceeding about 0.60 g/cm³ tends to cause degradation in the assembling property of the holding sealing material, bent inorganic fibers inside the holding sealing material and damages to the honeycomb structural body. The upper limit of the GBD is desirably set to about 0.55 g/cm³.

[0319] The lower limit of the initial surface pressure of the holding sealing material housed inside the metal shell is desirably set to about 40 kPa. The initial surface pressure of less than about 40 kPa tends to cause a failure in obtaining a firmly secured state of the honeycomb structural body in the metal shell during use of the exhaust gas purifying device, due to a reduction in surface pressure with elapsed time. The lower limit of the initial surface pressure is desirably set to about 70 kPa.

[0320] In the case where, with respect to the metal shell, a press-in system is adopted as an assembling system for the honeycomb structural body, a metal cylinder member **330**, having an O-shaped cross section as shown in FIG. 10, is used, and in the case where a canning system is adopted, a plurality of members (that is, clam shells), obtained by dividing a metal cylinder member **332** having an O-shaped cross section as shown in FIG. 12, are used. Moreover, in the case where a wind-tightening system is adopted, a metal cylindrical member having a C-shaped or U-shaped cross-section with only one slit (opening) extending along the length direction is used. Here, in the case where the canning system and the wind-tightening system are used, upon assembling the honeycomb structural body, a method is used in which a member having a honeycomb structural body on which the holding sealing material is secured, is housed in the metal shell and the opening ends thereof are joined through a welding process, a bonding process, a bolt-tightening process or the like in the tightened state of the metal shell.

[0321] With respect to the metal constituting the metal shell, metal having superior heat resistance and impact-resistance, such as stainless, is desirably used.

[0322] The honeycomb structural body is not particularly limited and, for example, the honeycomb structural body of the first aspect of the present invention may be used.

[0323] Moreover, different from the honeycomb structural body of the first aspect of the present invention, the honeycomb structural body is not necessarily designed to use inorganic fibers having the aforementioned composition that is soluble in physiological saline as the sealing material layer, and may have approximately the same structure as the honeycomb structural body of the first aspect of the present invention, with a conventionally known layer being used as the sealing material layer.

[0324] An exhaust gas purifying device **300**, having the above-mentioned structure, functions at least a diesel particulate filter (DPF), and collects particulates in exhaust gases discharged from an internal combustion system such as a diesel engine, and purifies the exhaust gases.

[0325] In other words, the exhaust gases are directed into a metal shell **330** through an introducing pipe, and allowed to flow into the honeycomb structural body **320** through one of the through holes **321** and pass through the wall portion **323**; thus, after the particulates in the exhaust gases have been collected by the partition wall **323**, the resulting exhaust gases are discharged out of the honeycomb structural body **320** from another through hole **321**, and further discharged outside through an exhaust pipe.

[0326] In the exhaust gas purifying device **300**, after a large quantity of particulates have been accumulated on the partition wall **323** of the honeycomb structural body **320** to cause an increase in pressure loss, the honeycomb structural body **320** is subjected to a regenerating process.

[0327] In the regenerating process, a high-temperature gas is allowed to flow into the through holes **321** of the honeycomb structural body **320** so that the honeycomb structural body **320** is heated; thus, the particulates accumulated on the partition wall **323** are burned and eliminated. Here, the high-temperature gas is generated by a heating means or the like that is placed on the exhaust gas inlet side inside the metal shell **330**.

[0328] Moreover, a catalyst may be supported on the honeycomb structural body, and in the case where the catalyst is supported thereon, by using the inorganic fibers as described above, the NO_x absorbing and storing effects are provided to prevent the catalyst from being poisoned; thus, it becomes possible to provide superior exhaust gas converting functions.

[0329] Next, description will be given of a manufacturing method for the exhaust gas purifying device according to the third aspect of the present invention.

[0330] First, a honeycomb structural body and a holding sealing material are manufactured in a separated manner.

[0331] The honeycomb structural body can be manufactured by using the same method as the method for manufacturing the honeycomb structural body according to the first aspect of the present invention.

[0332] For example, the above-mentioned holding sealing material is suitably formed through a method in which a formed body of the inorganic fibers, shaped into a holding sealing material **310**, is impregnated with the organic binder.

[0333] With respect to the method for manufacturing the formed body of the inorganic fibers shaped into the holding sealing material, conventionally known methods may be

used, and, for example, a method which includes a step (1-1) in which inorganic fibers are manufactured through a blowing method, a spinning method, a sol-gel method and the like, a step (1-2) in which the inorganic fibers are molded into a formed body of mat-shaped inorganic fibers, and a step (1-3) in which the formed body is punched into a desired shape by using a metal mold, is adopted.

[0334] The method in which the formed body of the inorganic fibers, formed into the holding sealing material, is impregnated with the organic binder is not particularly limited, and the following methods and the like may be adopted: a method in which a latex, formed by dispersing the organic binder in water by using an emulsifier, is prepared and the formed body is immersed in this latex; a method in which the latex is atomized into a fog state by using a spray and blown onto the formed body; and a method in which the latex is directly applied to or dripped onto the formed body. Among these, the method in which the formed body is immersed in the latex is desirably used. Thus, the formed body, even the inside thereof, is positively and evenly impregnated with the organic binder.

[0335] With respect to the content of the organic binder in the latex, a lower limit value is desirably set to about 0.5% by weight, and an upper limit value is desirably set to about 2% by weight. When the content of the organic binder in the latex is less than about 0.5% by weight, the resulting holding sealing material tends to easily cause scattering of the inorganic fibers. In contrast, when the content of the organic binder in the latex exceeds about 2% by weight, the content of the inorganic binder in the holding sealing material is too high, resulting in a difficulty in clearing the regulation value for exhaust gases.

[0336] With respect to the viscosity of the latex, a lower limit value is desirably set to about 10 mPa·s, and an upper limit value is desirably set to about 40 mPa·s.

[0337] After the formed body of the inorganic fibers have been impregnated with the organic binder, the resulting material is subjected to heating and drying processes while being compressed in the thickness direction of the holding sealing material so that excessive moisture derived from the latex is removed, and the holding sealing material is compressed in the thickness direction to be made thinner.

[0338] Moreover, the holding sealing material is desirably subjected to a needle punching process. This needle punching process is carried out so that the holding sealing material is stuck by needles (styluses) so that the upper and lower inorganic fibers are entangled; thus, the holding sealing material is allowed to have sufficient elasticity. Here, water flows or the like, simulating a needle state, may also be used as the needles.

[0339] The above-mentioned needle punching process may be carried out prior to the impregnation with the organic binder, or may be carried out after the impregnation therewith.

[0340] The holding sealing material, formed through the above-mentioned processes, is wound around the periphery of the honeycomb structural body manufactured through the above-mentioned processes in the length direction, and secured thereon.

[0341] The method for winding the holding sealing material around the honeycomb structural body and securing

thereon is not particularly limited and, for example, a method for bonding the sealing material thereto with an adhesive or a tape and a method for binding the sealing material thereto with a string-shaped material may be used. Moreover, the sequence may proceed to the next step, with the sealing material being simply wound around without securing it by a special means.

[0342] Here, the string-shaped material is desirably made from a material that is decomposed by heat.

[0343] Next, the honeycomb structural body wound with the holding sealing material is housed in the metal shell and secured therein so that an exhaust gas purifying device of the present invention is completed.

[0344] With respect to the method for housing the honeycomb structural body wound with the holding sealing material in the metal shell, as described above, the press-in method, the canning method, the wind-tightening method and the like may be employed. In the press-in method, the honeycomb structural body is pressed in from one end of a metal cylinder member having an O-shaped cross section as shown in FIG. 10 so that the honeycomb structural body wound with the holding sealing material is housed in the metal cylinder member and secured therein.

[0345] In the canning system, after the honeycomb structural body wound with the holding sealing material has been placed inside a semi-cylinder lower shell 332b as shown in FIG. 12, a semi-cylinder upper shell 332a is placed so that through holes 334a of an upper-shell securing portion 333a formed on the upper shell 332a are just superposed on through holes 334b of a lower-shell securing portion 333b formed on the lower-shell 332b. Then, bolts 335 are inserted through the through holes 334a and 334b and secured by nuts and the like so that the honeycomb structural body wound with the holding sealing material is housed in the metal cylinder member 332 having an O-shaped cross section and secured therein. Here, instead of the bolt-tightening process, a method, such as a welding method, a bonding method or the like, may be used.

[0346] In the wind-tightening system, after the honeycomb structural body wound with the holding sealing material has been housed inside the metal cylinder member having a C-shaped or U-shaped cross section, which has only one slit (opening) extending along the length direction, and with the metal shells being tightened in the same manner as the above-mentioned canning system, the opening ends are joined to each other through a method, such as a welding method, a bonding method, a bolt-tightening method or the like, and secured to each other.

[0347] Thus, an exhaust gas purifying device according to the third aspect of the present invention is manufactured through the above-mentioned processes.

EXAMPLES

Example 1

[0348] (1) Powder of α -type silicon carbide having an average particle diameter of 10 μm (60% by weight) and powder of α -type silicon carbide having an average particle diameter of 0.5 μm (40% by weight) were wet-mixed, and to 100 parts by weight of the resulting mixture were added and kneaded 5 parts by weight of an organic binder (methyl

cellulose) and 10 parts by weight of water to obtain a mixed composition. Next, after a slight amount of a plasticizer and a lubricant had been added to the kneaded matter and further kneaded, the resulting matter was extrusion-molded so that a raw formed body was manufactured.

[0349] Next, after the above-mentioned raw formed body had been dried by using a microwave drier or the like, predetermined through holes were filled with a sealing material (plug) paste having the same composition as the raw formed body, and after this had been again dried by using a drier, the resulting product was degreased at 400° C., and sintered at 2200° C. in a normal-pressure argon atmosphere for 3 hours to manufacture a porous ceramic member having a shape shown in FIG. 3A and FIG. 3B, which was a silicon carbide sintered body and had a size of 34 mm×34 mm×300 mm, the number of through holes of 31 pcs/cm² and a thickness of the partition wall of 0.3 mm.

[0350] (2) By using a heat resistant sealing material paste (adhesive paste) containing: 31% by weight of inorganic fibers having an average fiber diameter of 3 μm and an average fiber length of 30 μm , composed of 85% by weight of silica and 15% by weight of magnesium oxide (see Table 1); 22% by weight of silicon carbide particles having an average particle diameter of 0.6 μm ; 16% by weight of silica sol; 1% by weight of carboxymethyl cellulose; and 30% by weight of water, a large number of the porous ceramic members were combined with one another by using the above-mentioned method to prepare a ceramic laminated body.

[0351] Here, with respect to the inorganic fibers, after blending the above-mentioned materials, the resulting mixture was heated and melted to prepare the fibers by using a blowing method.

[0352] Moreover, the solubility in physiological saline of the inorganic fibers was measured through the following method.

[0353] (I) First, 2.5 g of inorganic fibers were suspended in distilled water by using a blender for food, and this was then allowed to stand still to precipitate the inorganic fibers, and after the supernatant liquid had been removed through decantation, the resulting solution was dried at 110° C. to remove the remaining liquid so that an inorganic fiber sample was prepared.

[0354] (II) Sodium chloride (6.780 g), ammonium chloride (0.540 g), sodium hydrogen carbonate (2.270 g), disodium hydrogenphosphate (0.170 g), sodium citrate dihydrate (0.060 g), glycine (0.450 g) and sulfuric acid (0.050 g, specific gravity: 1.84) were diluted in distilled water (1 liter) to prepare physiological saline.

[0355] (III) The inorganic fiber sample (0.50 g) prepared in (I) and the physiological saline (25 cm³) prepared in (II) were put into a centrifugal tube, and after having been fully shaken, this was subjected to a treatment by a shaking incubator at 20 cycles/min at 37° C. for 5 hours. Then, the centrifugal tube was taken out, and subjected to a centrifugal separation process at 4500 rpm for 5 minutes; thus, the supernatant liquid thereof was taken out by using an injector.

[0356] (IV) Next, the supernatant liquid was filtered through a filter (0.45 μm , cellulose nitrate membrane filter), and the resulting sample was subjected to an atomic absorp-

tion analysis so that the solubility in physiological saline of each of silica, calcium oxide and magnesium oxide was measured. The results are shown in Table 1.

[0357] Here, Table 1 shows the solubility of inorganic fibers as a whole.

[0358] (3) Successively, the ceramic laminated body was cut by using a diamond cutter in parallel with the length direction thereof to form a cylindrical ceramic block as shown in FIG. 2.

[0359] (4) Next, by using a sealing material paste having the same composition as the paste used as the adhesive (sealing material) paste, a sealing material paste layer was formed on the peripheral portion of the ceramic block. Then, the sealing material paste layer was dried at 120° C. so that a cylindrical honeycomb structural body having a thickness of 1.0 mm in the sealing material layer formed between the porous ceramic members as well as on the peripheral portion of the ceramic block, with a diameter of 143.8 mm, such as a honeycomb structural body 20 shown in FIG. 2, was manufactured.

[0360] This honeycomb structural body was secured in a cylindrical metal shell, made of stainless, having an inner diameter of 152 mm and a length of 300 mm, through a holding sealing material comprising an inorganic fiber mat material (average fiber diameter: 3 μm, average fiber length: 30 mm, thickness: 8 mm, bulk density: 0.15) made of alumina fibers composed of 70% by weight of an alumina component and 30% by weight of a silica component.

[0361] Here, in the columns of members of Table 1, adhesives and sealing materials that are indicated with white circle represent the use of inorganic fibers having compositions shown in Table 1 as a sealing material (adhesive) to be used for bonding porous ceramic members and as a sealing material to be formed on the peripheral portion of the ceramic block.

[0362] The same is true in the following examples and comparative examples, and holding sealing materials that are indicated with white circle represent the use of inorganic fibers having compositions shown in Table 1 as the inorganic fibers forming the holding sealing material, and when only the adhesives are indicated with white circle, these cases represent that inorganic fibers having compositions shown in Table 1 are used as only the adhesives, and when only the sealing materials are indicated with white circle, these cases represent that inorganic fibers having compositions shown in Table 1 are used as only the sealing materials.

[0363] Moreover, when members are not indicated with white circle and the column of the base member of the honeycomb structural body indicates inorganic fibers, this case represents that inorganic fibers having compositions shown in Table 1 are used as the base member forming the honeycomb structural body.

Example 2

[0364] The same processes as those of Example 1 were carried out except that inorganic fibers having an average fiber diameter of 3 μm and an average fiber length of 30 μm, composed of 80% by weight of silica and 20% by weight of magnesium oxide, as shown in Table 1, were used to manufacture a honeycomb structural body.

[0365] The solubility of the inorganic fibers was measured in the same manner as Example 1.

Example 3

[0366] The same processes as those of Example 1 were carried out except that inorganic fibers having an average fiber diameter of 3 μm and an average fiber length of 30 μm, composed of 70% by weight of silica and 30% by weight of magnesium oxide, as shown in Table 1, were used to manufacture a honeycomb structural body.

[0367] The solubility of the inorganic fibers was measured in the same manner as Example 1.

Example 4

[0368] The same processes as those of Example 1 were carried out except that inorganic fibers having an average fiber diameter of 3 μm and an average fiber length of 30 μm, composed of 60% by weight of silica and 40% by weight of magnesium oxide, as shown in Table 1, were used to manufacture a honeycomb structural body.

[0369] The solubility of the inorganic fibers was measured in the same manner as Example 1.

Example 5

[0370] (1) First, the same processes as those of Example 1 were carried out to manufacture a porous ceramic member.

[0371] (2) By using a heat resistant sealing material paste containing 30% by weight of alumina fibers having a fiber length of 0.2 μm, 21% by weight of silicon carbide having an average particle diameter of 0.6 μm, 15% by weight of silica sol, 5.6% by weight of carboxymethyl cellulose and 28.4% by weight of water, a large number of the porous ceramic members were combined with one another in the same manner as Example 1 to prepare a ceramic laminated body.

[0372] (3) Successively, the ceramic laminated body was cut by using a diamond cutter in parallel with the length direction thereof to form a cylindrical ceramic block as shown in FIG. 2.

[0373] (4) Next, by using a heat resistant sealing material paste containing: 31% by weight of inorganic fibers having an average fiber diameter of 3 μm and an average fiber length of 30 μm, composed of 85% by weight of silica and 15% by weight of magnesium oxide; 22% by weight of silicon carbide particles having an average particle diameter of 0.6 μm; 16% by weight of silica sol; 1% by weight of carboxymethyl cellulose; and 30% by weight of water as shown in Table 1, a sealing material paste layer was formed on the peripheral portion of the ceramic block. Here, with respect to the inorganic fibers, after blending the above-mentioned materials, the resulting mixture was heated and melted to prepare the fibers by using a blowing method. Moreover, the solubility of the inorganic fibers was measured in the same manner as Example 1.

[0374] Then, the sealing material paste layer was dried so that a cylindrical honeycomb structural body, such as a honeycomb structural body 20 shown in FIG. 2, having a thickness of 1.0 mm in the sealing material layer formed between the porous ceramic members as well as on the

peripheral portion of the ceramic block, with a diameter of 143.8 mm, was manufactured.

[0375] This honeycomb structural body was secured in a cylindrical metal shell, made of stainless, having an inner diameter of 152 mm and a length of 300 mm, through a holding sealing material comprising an inorganic fiber mat material (average fiber diameter: 3 μm , average fiber length: 30 mm, thickness: 8 mm, bulk density: 0.15) made of alumina fibers composed of 70% by weight of an alumina component and 30% by weight of a silica component.

Example 6

[0376] The same processes as those of Example 5 were carried out except that inorganic fibers having an average fiber diameter of 3 μm and an average fiber length of 30 μm , composed of 80% by weight of silica and 20% by weight of magnesium oxide, as shown in Table 1, were used as a sealing material in step (4) of Example 5 to manufacture a honeycomb structural body.

[0377] The solubility of the inorganic fibers was measured in the same manner as Example 1.

Example 7

[0378] The same processes as those of Example 5 were carried out except that inorganic fibers having an average fiber diameter of 3 μm and an average fiber length of 30 μm , composed of 70% by weight of silica and 30% by weight of magnesium oxide, as shown in Table 1, were used as a sealing material in step (4) of Example 5 to manufacture a honeycomb structural body.

[0379] The solubility of the inorganic fibers was measured in the same manner as Example 1.

Example 8

[0380] The same processes as those of Example 5 were carried out except that inorganic fibers having an average fiber diameter of 3 μm and an average fiber length of 30 μm , composed of 60% by weight of silica and 40% by weight of magnesium oxide, as shown in Table 1, were used as a sealing material in step (4) of Example 5 to manufacture a honeycomb structural body.

[0381] The solubility of the inorganic fibers was measured in the same manner as Example 1.

Example 9

[0382] (1) First, porous ceramic members were manufactured in the same manner as Example 1.

[0383] (2) By using a heat resistant adhesive (sealing material) paste containing: 31% by weight of inorganic fibers having an average fiber diameter of 3 μm and an average fiber length of 30 μm , composed of 85% by weight of silica and 15% by weight of magnesium oxide; 22% by weight of silicon carbide particles having an average particle diameter of 0.6 μm ; 16% by weight of silica sol, 1% by weight of carboxymethyl cellulose; and 30% by weight of water as shown in Table 1, a number of the porous ceramic members were combined with one another by using the aforementioned method to form a ceramic laminated body.

[0384] Here, with respect to the inorganic fibers, after blending the above-mentioned materials, the resulting mixture was heated and melted to prepare the fibers by using a blowing method.

[0385] Moreover, the solubility of the inorganic fibers was measured in the same manner as Example 1.

[0386] (3) Successively, the ceramic laminated body was cut by using a diamond cutter in parallel with the length direction thereof to form a cylindrical ceramic block as shown in FIG. 2.

[0387] (4) Next, ceramic fibers (23.3% by weight) comprising alumina silicate (shot content: 3%, fiber length: 0.1 to 100 mm), which served as inorganic fibers; silicon carbide powder having an average particle diameter of 0.3 μm (30.2% by weight), which served as inorganic particles; silica sol (SiO_2 content in the sol: 30% by weight) (7% by weight), which served as an inorganic binder; carboxymethyl cellulose (0.5% by weight), which served as an organic binder; and water (39% by weight) were mixed and kneaded to prepare a sealing material paste, and a sealing material paste layer was formed on the peripheral portion of the ceramic block by using the above-mentioned sealing material paste.

[0388] Then, the sealing material paste layer was dried so that a cylindrical honeycomb structural body having a thickness of 1.0 mm in the sealing material layer formed between the porous ceramic members as well as on the peripheral portion of the ceramic block, with a diameter of 143.8 mm, such as a honeycomb structural body 20 shown in FIG. 2, was manufactured.

[0389] This honeycomb structural body was secured in a cylindrical metal shell, made of stainless, having an inner diameter of 152 mm and a length of 300 mm, through a holding sealing material comprising an inorganic fiber mat material (average fiber diameter: 3 μm , average fiber length: 30 mm, thickness: 8 mm, bulk density: 0.15) made of alumina fibers composed of 70% by weight of an alumina component and 30% by weight of a silica component.

Example 10

[0390] The same processes as those of Example 9 were carried out except that inorganic fibers having an average fiber diameter of 3 μm and an average fiber length of 30 μm , composed of 80% by weight of silica and 20% by weight of magnesium oxide, as shown in Table 1, were used as an adhesive paste in step (2) of Example 9 to manufacture a honeycomb structural body.

[0391] The solubility of the inorganic fibers was measured in the same manner as Example 1.

Example 11

[0392] The same processes as those of Example 9 were carried out except that inorganic fibers having an average fiber diameter of 3 μm and an average fiber length of 30 μm , composed of 70% by weight of silica and 30% by weight of magnesium oxide, as shown in Table 1, were used as an adhesive paste in step (2) of Example 9 to manufacture a honeycomb structural body.

[0393] The solubility of the inorganic fibers was measured in the same manner as Example 1.

Example 12

[0394] The same processes as those of Example 9 were carried out except that inorganic fibers having an average fiber diameter of 3 μm and an average fiber length of 30 μm , composed of 60% by weight of silica and 40% by weight of magnesium oxide, as shown in Table 1, were used as an adhesive paste in step (2) of Example 9 to manufacture a honeycomb structural body.

[0395] The solubility of the inorganic fibers was measured in the same manner as Example 1.

Example 13

[0396] (1) A material paste was prepared by mixing and kneading 40 parts by weight of talc having an average particle diameter of 10 μm , 10 parts by weight of kaolin having an average particle diameter of 9 μm , 17 parts by weight of alumina having an average particle diameter of 9.5 μm , 16 parts by weight of aluminum hydroxide having an average particle diameter of 5 μm , 15 parts by weight of silica having an average particle diameter of 10 μm , 30 parts by weight of graphite having an average particle diameter of 10 μm , 17 parts by weight of a molding auxiliary (ethylene glycol) and 25 parts by weight of water.

[0397] (2) Next, the above-mentioned material paste was loaded into an extrusion-molding machine and extrusion-molded to form a pillar-shaped ceramic formed body having the approximately same shape as a honeycomb structural body 320 shown in FIG. 9 at an extruding rate of 10 cm/min, and the ceramic formed body was dried by using a microwave dryer to form a ceramic structural body.

[0398] (3) Next, talc having an average particle diameter of 10 μm (40 parts by weight), kaolin having an average particle diameter of 9 μm (10 parts by weight), alumina having an average particle diameter of 9.5 μm (17 parts by weight), aluminum hydroxide having an average particle diameter of 5 μm (16 parts by weight), silica having an average particle diameter of 10 μm (15 parts by weight), a lubricant comprising polyoxyethylene monobutyl ether (trade name: Unilube, made by NOF Corp.) (4 parts by weight), a solvent made from diethylene glycol mono-2-ethylhexyl ether (trade name: OX-20, made by Kyowa Hakko Kogyo Co., Ltd.) (11 parts by weight), a dispersant made from a phosphoric ester-based compound (trade name: PLYSURF, made by Dai-Ichi Kogyo Seiyaku Co., Ltd.) (2 parts by weight) and a binder prepared by dissolving n-butyl methacrylate in OX-20 (trade name: BINDER D, made by Toei Kasei Co., Ltd.) (5 parts by weight) were blended and uniformly mixed so that a filler (plug) paste was prepared. After the filler (plug) paste had been injected into predetermined through holes of the ceramic structural body, the resulting structural body was again dried by using a microwave dryer, and then degreased at 400° C., and fired at 1400° C. in a normal-pressure argon atmosphere for 3 hours to manufacture a cylindrical honeycomb structural body that was made from cordierite, and had a size of 143.8 mm in diameter and 300 mm in width, the number of through holes of 31 pcs/cm² and a thickness of the partition wall of 0.3 mm, as shown in FIG. 9.

[0399] (4) A mat-shaped inorganic fiber aggregated body (thickness: 8.5 mm, average fiber diameter: 3 μm , average fiber length: 30 mm), made from 85% by weight of silica and

15% by weight of magnesium oxide as shown in Table 1, was immersed in a latex (made by Zeon Corp.) containing 1% by weight of styrene-butadiene resin, and the resulting inorganic fiber aggregated body was then taken out, and dried at 120° C. for one hour while being compressed under 13 MPa; thus, a holding sealing material having a thickness of 8 mm, which contained 1% by weight of styrene-butadiene binder, was manufactured.

[0400] The solubility of the inorganic fibers was measured in the same manner as Example 1.

[0401] (5) The honeycomb structural body manufactured in the aforementioned step (3) was secured in a cylindrical metal shell, made of stainless, having an inner diameter of 151.8 mm and a length of 300 mm, through a holding sealing material manufactured in the aforementioned step (4).

Example 14

[0402] The same processes as those of Example 13 were carried out except that the holding sealing material was manufactured by using a mat-shaped inorganic fiber aggregated body (thickness: 8.5 mm, fiber diameter: 3 μm , fiber length: 30 mm) composed of 80% by weight of silica and 20% by weight of magnesium oxide, as shown in Table 1, in the step (4) of Example 13; thus, a honeycomb structural body was manufactured.

[0403] The solubility of the inorganic fibers was measured in the same manner as Example 1.

Example 15

[0404] The same processes as those of Example 13 were carried out except that the holding sealing material was manufactured by using a mat-shaped inorganic fiber aggregated body (thickness: 8.5 mm, fiber diameter: 3 μm , fiber length: 30 mm) composed of 70% by weight of silica and 30% by weight of magnesium oxide, as shown in Table 1, in the step (4) of Example 13; thus, a honeycomb structural body was manufactured.

[0405] The solubility of the inorganic fibers was measured in the same manner as Example 1.

Example 16

[0406] The same processes as those of Example 13 were carried out except that the holding sealing material was manufactured by using a mat-shaped inorganic fiber aggregated body (thickness: 8.5 mm, fiber diameter: 3 μm , fiber length: 30 mm) composed of 60% by weight of silica and 40% by weight of magnesium oxide, as shown in Table 1, in the step (4) of Example 13; thus, a honeycomb structural body was manufactured.

[0407] The solubility of the inorganic fibers was measured in the same manner as Example 1.

Example 17

[0408] (1) Inorganic fibers having an average fiber diameter of 5 μm and an average fiber length of 300 μm , composed of 85% by weight of silica and 15% by weight of magnesium oxide, were dispersed in water (1 L) at a ratio of log therein, and in addition to these, 5% by weight of silica sol serving as an inorganic binder and 3% by weight of an acrylic latex serving as an organic binder were added

thereto. Further, a slight amount of aluminum sulfate serving as a coagulant and polyacrylic amide serving as an aggregation agent were further added thereto, and the mixture was sufficiently stirred to prepare a slurry for paper-making.

[0409] The solubility of the inorganic fibers was measured in the same manner as Example 1.

[0410] (2) The slurry, obtained in the step (1), was subjected to a paper-making process by using a perforated mesh having a diameter of 143.8 mm in which holes having a size of 4.5 mm×4.5 mm were formed with mutual intervals of 2 mm over approximately the entire face thereof, and the resulting matter was dried at a temperature of 150° C. so that sheets A from paper-making process, which had holes having a size of 4.5 mm×4.5 mm formed over the entire surface with intervals of 2 mm, and a thickness of 1 mm, were obtained.

[0411] Moreover, in order to obtain two-ends-use sheets, the same paper-making and drying processes were carried out by using a mesh in which holes having a size of 4.5 mm×4.5 mm were formed in a checked pattern so that sheets B from paper-making process in which holes having a size of 4.5 mm×4.5 mm were formed in a checked pattern were obtained.

[0412] (3) A casing (cylindrical metal container) having a pressing member on one side was placed with the side to which the pressing member was attached facing down. After three of the sheets B obtained from paper-making process had been laminated, three hundred of the sheets A obtained from paper-making process were laminated, and three of the sheets B obtained from paper-making process were lastly laminated therein, and this was further subjected to a pressing process, and another pressing member is also put on the other side and secured thereon so that a honeycomb structural body having a length of 300 mm, comprising a laminated body, was prepared. In this process, the respective sheets were laminated so that the through holes were superposed on one another.

Example 18

[0413] The same processes as those of Example 17 were carried out except that the slurry for paper-making was prepared by using inorganic fibers having an average fiber diameter of 5 μm and an average fiber length of 300 μm , composed of 80% by weight of silica and 20% by weight of magnesium oxide, as shown in Table 1, in the step (1) of Example 17; thus, a honeycomb structural body was manufactured.

[0414] The solubility of the inorganic fibers was measured in the same manner as Example 1.

Example 19

[0415] The same processes as those of Example 17 were carried out except that the slurry for paper-making was prepared by using inorganic fibers having an average fiber diameter of 5 μm and an average fiber length of 300 μm , composed of 70% by weight of silica and 30% by weight of magnesium oxide, as shown in Table 1, in the step (1) of Example 17; thus, a honeycomb structural body was manufactured.

[0416] The solubility of the inorganic fibers was measured in the same manner as Example 1.

Example 20

[0417] The same processes as those of Example 17 were carried out except that the slurry for paper-making was prepared by using inorganic fibers having an average fiber diameter of 5 μm and an average fiber length of 300 μm , composed of 60% by weight of silica and 40% by weight of magnesium oxide, as shown in Table 1, in the step (1) of Example 17; thus, a honeycomb structural body was manufactured.

[0418] The solubility of the inorganic fibers was measured in the same manner as Example 1.

Examples 21 to 37

[0419] The same processes as those of Example 1 were carried out except that inorganic fibers having an average fiber diameter of 3 μm and an average fiber length of 30 μm , the composition of which is shown in Table 1 and Table 2 were used to manufacture a honeycomb structural body.

[0420] The solubility of the inorganic fibers was measured in the same manner as Example 1.

Comparative Example 1

[0421] The same processes as those of Example 1 were carried out except that inorganic fibers having an average fiber diameter of 3 μm and an average fiber length of 30 μm , composed of 50% by weight of silica and 50% by weight of magnesium oxide, as shown in Table 2, were used as the inorganic fibers forming the adhesive paste and the sealing material paste; thus, a honeycomb structural body was manufactured.

[0422] The solubility of the inorganic fibers was measured in the same manner as Example 1.

Comparative Example 2

[0423] The same processes as those of Example 1 were carried out except that alumina silicate fibers (IBIWOOL, made by IBIDEN Co., Ltd.) having an average fiber diameter of 3 μm and an average fiber length of 30 μm , composed of 50% by weight of silica and 50% by weight of alumina, as shown in Table 2, were used as the inorganic fibers forming the adhesive paste and the sealing material paste; thus, a honeycomb structural body was manufactured.

[0424] The solubility of the alumina silicate fibers was measured in the same manner as Example 1.

Comparative Example 3

[0425] The same processes as those of Example 1 were carried out except that inorganic fibers having an average fiber diameter of 3 μm and an average fiber length of 30 μm , composed of 50% by weight of silica, 25% by weight of calcium oxide and 25% by weight of magnesium oxide, as shown in Table 2, were used as the inorganic fibers forming the adhesive paste and the sealing material paste; thus, a honeycomb structural body was manufactured.

[0426] The solubility of the inorganic fibers was measured in the same manner as Example 1.

Comparative Example 4

[0427] The same processes as those of Example 5 were carried out except that alumina silicate fibers (IBIWOOL,

made by IBIDEN Co., Ltd.) having an average fiber diameter of 3 μm and an average fiber length of 30 μm , composed of 50% by weight of silica and 50% by weight of alumina, as shown in Table 2, were used as the inorganic fibers forming the sealing material paste in the step (4) of Example 5; thus, a honeycomb structural body was manufactured.

[0428] The solubility of the alumina silicate fibers was measured in the same manner as Example 1.

Comparative Example 5

[0429] The same processes as Example 9 were carried out except that inorganic fibers having an average fiber diameter of 3 μm and an average fiber length of 30 μm , composed of 50% by weight of silica, 25% by weight of calcium oxide and 25% by weight of magnesium oxide, as shown in Table 2, were used as the inorganic fibers forming the adhesive paste in the step (2) of Example 9; thus, a honeycomb structural body was manufactured.

[0430] The solubility of the inorganic fibers was measured in the same manner as Example 1.

Comparative Example 6

[0431] The same processes as those of Example 9 were carried out except that alumina silicate fibers (IBIWOOL, made by IBIDEN Co., Ltd.) having an average fiber diameter of 3 μm and an average fiber length of 30 μm , composed of 50% by weight of silica and 50% by weight of alumina, as shown in Table 2, were used as the inorganic fibers forming the adhesive paste in the step (2) of Example 9; thus, a honeycomb structural body was manufactured.

[0432] The solubility of the alumina silicate fibers was measured in the same manner as Example 1.

Comparative Example 7

[0433] In the step (4) of Example 13, the same processes as those of Example 13 were carried out except that the holding sealing material was manufactured by using a mat-shaped inorganic fiber aggregated body (thickness: 8.5 mm, fiber diameter: 3 μm , fiber length: 30 mm) composed of 50% by weight of silica, 25% by weight of calcium oxide and 25% by weight of magnesium oxide, as shown in Table 2; thus, a honeycomb structural body was manufactured.

[0434] The solubility of the inorganic fibers was measured in the same manner as Example 1.

Comparative Example 8

[0435] The same processes as those of Example 13 were carried out except that the holding sealing material was manufactured by using a mat-shaped inorganic fiber aggregated body (thickness: 8.5 mm, fiber diameter: 3 μm , fiber length: 30 mm) composed of 50% by weight of silica and 50% by weight of alumina, as shown in Table 2, in the step (4) of Example 13; thus, a honeycomb structural body was manufactured.

[0436] The solubility of the inorganic fibers was measured in the same manner as Example 1.

Comparative Example 9

[0437] The same processes as those of Example 17 were carried out except that the slurry for paper-making was

prepared by using inorganic fibers having an average fiber diameter of 5 μm and an average fiber length of 300 μm , composed of 50% by weight of silica, 25% by weight of calcium oxide and 25% by weight of magnesium oxide, as shown in Table 2, in the step (1) of Example 17; thus, a honeycomb structural body was manufactured.

[0438] The solubility of the inorganic fibers was measured in the same manner as Example 1.

Comparative Example 10

[0439] The same processes as those of Example 17 were carried out except that the slurry for paper-making was prepared by using inorganic fibers having an average fiber diameter of 5 μm and an average fiber length of 200 μm , composed of 50% by weight of silica and 50% by weight of alumina, as shown in Table 2, in the step (1) of Example 17; thus, a honeycomb structural body was manufactured.

[0440] The solubility of the alumina silicate fibers was measured in the same manner as Example 1.

[0441] (Evaluation on Converting Property of NOx)

[0442] Each of the honeycomb structural bodies according to Examples 1 to 37 and Comparative Examples 1 to 10 was placed in an exhaust passage in an engine to prepare an exhaust gas purifying device, and the honeycomb structural body was maintained at 400° C. while N₂ gas was allowed to flow through the honeycomb structural body.

[0443] Next, a simulation gas having approximately the same composition as exhaust gases from a diesel engine except that no particulates were contained was allowed to flow through the honeycomb structural body at 130 L/min, and after a lapse of one minute, gases were sampled from the inlet side as well as from the outlet side of the honeycomb structural body; thus, by measuring the amounts of NOx contained in these gases, the converting property of NOx was evaluated. The results of evaluation are shown in Tables 1 and 2.

[0444] Here, the converting property of NOx was evaluated based upon a rate of NOx gas concentration of the gas on the outlet side to NOx gas concentration of the gas on the inlet side of the honeycomb structural body.

[0445] With respect to the simulation gas, gas which contains 1800 ppm of HC (hydrocarbon: organic compound composed of only carbon and hydrogen), 300 ppm of CO, 250 ppm of NOx, 9 ppm of SOx, 10% of H₂O and 10% of O₂ was used.

[0446] The results of the tests are shown in Tables 1 and 2.

[0447] (Evaluation on Absorbing Property of SOx)

[0448] Each of the honeycomb structural bodies according to Examples 1 to 37 and Comparative Examples 1 to 10 was placed in an exhaust passage in an engine to prepare an exhaust gas purifying device, and the honeycomb structural body was maintained at 200° C. while N₂ gas was allowed to flow through the honeycomb structural body.

[0449] Next, a simulation gas having approximately the same composition as the simulation gas used for the evaluation of the converting property of NOx was allowed to flow through the honeycomb structural body at 130 L/minute, and

after a lapse of 10 minutes, gases were sampled from the inlet side as well as from the outlet side of the honeycomb structural body; thus, by measuring the amounts of SOx contained in these gases, the converting property of SOx was evaluated. The results of evaluation are shown in Tables 1 and 2.

[0450] Here, the converting property of SOx was evaluated based upon a rate of SOx gas concentration of the gas on the outlet side to SOx gas concentration of the gas on the inlet side of the honeycomb structural body.

[0451] (Durability to Cycle Driving)

[0452] Each of honeycomb structural bodies according to Examples 1 to 37 and Comparative Examples 1 to 10 was placed in an exhaust passage of an engine, and a catalyst supporting body (diameter: 144 mm, length: 100 mm, cell (through hole) density: 400 cells/inch², platinum supported amount: 5 g/L) of a honeycomb structural body made from commercially available cordierite was placed on the gas inlet side from the honeycomb structural body to form an exhaust gas purifying device. The engine was driven at the number of revolutions of 3000 min⁻¹ with a torque of 50 Nm

and particulates were collected for 7 hours. The amount of particulates thus collected was 8 g/L.

[0453] Thereafter, the engine was driven at the number of revolutions of 1250 min⁻¹ with a torque of 60 Nm, and after the filter temperature had been made constant, this state was maintained for one minute, and a post-injection process was carried out so that the oxidizing catalyst, placed on the front side, was utilized to increase the exhaust temperature to burn particulates.

[0454] The condition of the post-injection was set such that the center temperature of the honeycomb structural body became almost at the constant temperature of 600° C. in one minute after the beginning of the process. Then the above-mentioned process was repeated for 10 times. After that, the existence of the displacement between the honeycomb structural body and the metal shell was visually observed. Incidentally, regarding each of the honeycomb structural body according to Examples 17 to 20 and comparative examples 9 and 10, the existence of the displacement between the honeycomb structural body and the casing was visually observed. The results are shown in Table 1 and 2.

TABLE 1-1

Base material of honeycomb structural body	Member		Inorganic fiber									Typical metal of Group III
			Holding			Composition						
						Alkali metal			Alkali-earth metal			
						SiO ₂ (wt %)	K ₂ O (wt %)	Na ₂ O (wt %)	MgO (wt %)	CaO (wt %)	Al ₂ O ₃ (wt %)	
Example 1	SiC	○	○	85			15					
Example 2	SiC	○	○	80			20					
Example 3	SiC	○	○	70			30					
Example 4	SiC	○	○	60			40					
Example 5	SiC		○	85			15					
Example 6	SiC		○	80			20					
Example 7	SiC		○	70			30					
Example 8	SiC		○	60			40					
Example 9	SiC	○		85			15					
Example 10	SiC	○		80			20					
Example 11	SiC	○		70			30					
Example 12	SiC	○		60			40					
Example 13	Cordierite		○	85			15					
				Solubility (ppm)		Durability to cycle driving		Converting property of NOx (%)		Absorbing property of SOx (%)		
				Example 1	300	No displacement of filter		30		27		
				Example 2	400	No displacement of filter		32		28		
				Example 3	420	No displacement of filter		35		30		
				Example 4	430	No displacement of filter		39		33		
				Example 5	300	No displacement of filter		28		24		
				Example 6	400	No displacement of filter		30		25		
				Example 7	420	No displacement of filter		34		26		
				Example 8	430	No displacement of filter		35		28		
				Example 9	300	No displacement of filter		29		23		
				Example 10	400	No displacement of filter		31		24		
				Example 11	420	No displacement of filter		33		26		
				Example 12	430	No displacement of filter		37		28		
				Example 13	300	No displacement of filter		33		29		

[0455]

TABLE 1-2

Inorganic fiber												
Composition												
Base material of honey-comb structural body	Member			Alkali metal						Alkali-earth metal		Typical metal of Group III
	Adhesive	Sealing material	sealing material	SiO ₂ (wt %)	K ₂ O (wt %)	Na ₂ O (wt)	MgO (wt %)	CaO (wt %)	Al ₂ O ₃ (wt)	B ₂ O ₃ (wt %)		
												Holding
Example 14	Cordierite		○	80			20					
Example 15	Cordierite		○	70			30					
Example 16	Cordierite		○	60			40					
Example 17	Inorganic fiber			85			15					
Example 18	Inorganic fiber			80			20					
Example 19	Inorganic fiber			70			30					
Example 20	Inorganic fiber			60			40					
Example 21	SiC	○	○	85				15				
Example 22	SiC	○	○	80				20				
Example 23	SiC	○	○	70				30				
Example 24	SiC	○	○	60				40				
Example 25	SiC	○	○	70			5	25				
				Solubility (ppm)	Durability to cycle driving			Converting property of NOx (%)	Absorbing property of SOx (%)			
Example 14				400	No displacement of filter			35	31			
Example 15				420	No displacement of filter			38	33			
Example 16				430	No displacement of filter			40	36			
Example 17				300	No displacement of filter			51	43			
Example 18				400	No displacement of filter			54	45			
Example 19				420	No displacement of filter			56	47			
Example 20				430	No displacement of filter			59	48			
Example 21				300	No displacement of filter			31	27			
Example 22				400	No displacement of filter			32	29			
Example 23				420	No displacement of filter			36	31			
Example 24				430	No displacement of filter			40	33			
Example 25				410	No displacement of filter			35	30			

[0456]

TABLE 2-1

Inorganic fiber												
Composition												
Base material of honey-comb structural body	Member			Alkali metal						Alkali-earth metal		Typical metal of Group III
	Adhesive	Sealing material	sealing material	SiO ₂ (wt %)	K ₂ O (wt)	Na ₂ O (wt)	MgO (wt %)	CaO (wt %)	Al ₂ O ₃ (wt)	B ₂ O ₃ (wt %)		
												Holding
Example 26	SiC	○	○	60			15	25				
Example 27	SiC	○	○	85	15							
Example 28	SiC	○	○	80	20							
Example 29	SiC	○	○	85		15						
Example 30	SiC	○	○	80		20						
Example 31	SiC	○	○	85						15		

TABLE 2-1-continued

Example	SiC	○	○	Solubility (ppm)	Durability to cycle driving	Converting property of NOx (%)	Absorbing property of SOx (%)
Example 32	SiC	○	○	80			20
Example 33	SiC	○	○	70		15	15
Example 34	SiC	○	○	60		20	20
Example 35	SiC	○	○	70	5	25	
Example 36	SiC	○	○	60	15	25	
Example 37	SiC	○	○	60	10	25	5

Example	Solubility (ppm)	Durability to cycle driving	Converting property of NOx (%)	Absorbing property of SOx (%)
Example 26	410	No displacement of filter	36	32
Example 27	300	No displacement of filter	35	32
Example 28	400	No displacement of filter	38	36
Example 29	300	No displacement of filter	37	28
Example 30	400	No displacement of filter	40	30
Example 31	200	No displacement of filter	22	19
Example 32	250	No displacement of filter	25	21
Example 33	350	No displacement of filter	31	28
Example 34	430	No displacement of filter	33	30
Example 35	420	No displacement of filter	38	32
Example 36	430	No displacement of filter	42	35
Example 37	430	No displacement of filter	40	32

[0457]

TABLE 2-2

	Inorganic fiber										
	Base material of honey-comb structural body	Composition								Typical metal of Group	
		Member				Alkali				III	
		Adhesive	Sealing material	sealing material	Holding	Alkali metal	Alkali-earth metal	CaO	Al ₂ O ₃	B ₂ O ₃	
				SiO ₂ (wt %)	K ₂ O (wt %)	Na ₂ O (wt %)	MgO (wt %)	CaO (wt %)	Al ₂ O ₃ (wt %)	B ₂ O ₃ (wt %)	
Compar. Example 1	SiC	○	○		50			50			
Compar. Example 2	SiC	○	○		50				50		
Compar. Example 3	SiC	○	○		50		25	25			
Compar. Example 4	SiC		○		50				50		
Compar. Example 5	SiC	○			50		25	25			
Compar. Example 6	SiC	○			50				50		
Compar. Example 7	Cordierite		○		50		25	25			
Compar. Example 8	Cordierite		○		50				50		
Compar. Example 9	Inorganic fiber				50		25	25			
Compar. Example 10	Inorganic fiber				50				50		

Compar. Example	Solubility (ppm)	Durability to cycle driving	Converting property of NOx (%)	Absorbing property of SOx (%)
Compar. Example 1	440	Displacement of filter	41	35
Compar. Example 2	0	No displacement of filter	2	10
Compar. Example 3	600	Displacement of filter	40	35

TABLE 2-2-continued

Compar.	0	No displacement of filter	1	8
Example 4				
Compar.	600	Displacement of filter	39	31
Example 5				
Compar.	0	No displacement of filter	2	7
Example 6				
Compar.	600	Displacement of filter	42	38
Example 7				
Compar.	0	No displacement of filter	1	7
Example 8				
Compar.	600	Displacement of filter	61	51
Example 9				
Compar.	0	No displacement of filter	7	12
Example 10				

[0458] The results shown in Tables 1 and 2 indicate that the honeycomb structural bodies according to Examples 1 to 37 are superior in the NO_x converting property and SO_x absorbing property in comparison with the honeycomb structural bodies according to Comparative Examples 2, 4, 6, 8 and 10.

[0459] Moreover, since the inorganic fibers used for the honeycomb structural bodies according to Examples 1 to 37 are superior in solubility in physiological saline in comparison with the alumina silicate fibers used for the honeycomb structural bodies according to Comparative Examples 2, 4, 6, 8 and 10, it is considered that the material is less likely to give adverse effects on the human body.

[0460] Moreover, as shown in Table 1, although the honeycomb structural bodies according to Comparative Examples 1, 3, 5, 7 and 9 are superior in the converting property of NO_x and in the absorbing property of SO_x, and also superior in the solubility of inorganic fibers in physiological saline, a positional displacement occurs between the honeycomb structural body and the metal shell as a result of cycle driving operations.

[0461] The reason for this is presumably because, since the content of silica in the inorganic fibers is too low and the contents of calcium oxide and magnesium oxide are too high, the inorganic fibers become fragile in structure; thus, the inorganic fibers are damaged upon application of a thermal stress due to cycle driving operations.

[0462] In the case where a positional displacement occurs between the honeycomb structural body and the metal shell in this manner, a superior gas sealing property is no longer exerted; thus, a leak and the like of exhaust gases tend to occur to cause an insufficient purifying process for exhaust gases.

What is claimed as new and desired to be secured by Letters Patent of the United States is:

1. A pillar-shaped honeycomb structural body made of porous ceramics and comprising a large number of through holes that are placed in parallel with one another in the length direction with a wall portion interposed therebetween,

wherein

said honeycomb structural body has a sealing material layer formed thereon, and

said sealing material contains

inorganic fibers comprising:

at least about 60% and at most about 85% by weight of silica; and

at least about 15% and at most about 40% by weight of at least one kind of compound selected from the group consisting of an alkali metal compound, an alkali-earth metal compound and a boron compound.

2. The honeycomb structural body according to claim 1, comprising a plurality of pillar-shaped porous ceramic members that are combined to one another through a sealing material layer,

each of said pillar-shaped porous ceramic members including a large number of through holes that are placed in parallel with one another in the length direction with a partition wall interposed therebetween.

3. The honeycomb structural body according to claim 1 or 2,

wherein

said through holes are alternately sealed at end portions, and

the partition wall that separates the through holes functions as a filter.

4. The honeycomb structural body according to claim 1 or 2,

wherein

a catalyst is supported thereon.

5. The honeycomb structural body according to claim 1 or 2,

wherein

aperture ratios of through holes on both end faces are different from each other.

6. The honeycomb structural body according to claim 5, wherein

the aperture ratio of through holes on the end face of a gas inlet side is greater.

7. The honeycomb structural body according to claim 1, wherein
said porous ceramic material comprises at least one kind selected from the group consisting of nitride ceramics, carbide ceramics and oxide ceramics.
8. The honeycomb structural body according to claim 1, wherein
said porous ceramic material comprises silicon carbide.
9. The honeycomb structural body according to claim 1, wherein
said porous ceramic material comprises cordierite.
10. The honeycomb structural body according to claim 1, wherein
said alkali metal compound includes at least one kind selected from the group consisting of oxides of Na and oxides of K.
11. The honeycomb structural body according to claim 1, wherein
said alkali-earth metal compound includes at least one kind selected from the group consisting of oxides of Mg, oxides of Ca and oxides of Ba.
12. The honeycomb structural body according to claim 1, wherein
said boron compound includes an oxide of B.
13. The honeycomb structural body according to claim 1, wherein
solubility of said inorganic fibers in physiological saline is at least about 30 ppm.
14. The honeycomb structural body according to claim 1, wherein
said inorganic fibers have a function of absorbing and storing NO_x contained in an ambient gas.
15. The honeycomb structural body according to claim 1, wherein
the content of said inorganic fibers in the sealing material layer is at least about 10% and at most about 70% by weight.
16. The honeycomb structural body according to claim 15, wherein
the content of said inorganic fibers in the sealing material layer is in the range of about 20% to 40% by weight.
17. The honeycomb structural body according to claim 15, wherein
the content of said inorganic fibers in the sealing material layer is in the range of about 20% to 30% by weight.
18. The honeycomb structural body according to claim 1, wherein
said sealing material layer comprises an inorganic binder, an organic binder and inorganic particles in addition to said inorganic fibers.
19. A pillar-shaped honeycomb structural body mainly made of inorganic fibers and comprising a plurality of through holes that are placed in parallel with one another in the length direction with a wall portion interposed therebetween,
wherein
said inorganic fibers comprise at least about 60% and at most about 85% by weight of silica; and
at least about 15% and at most about 40% by weight of at least one kind of compound selected from the group consisting of an alkali metal compound, an alkali-earth metal compound and a boron compound.
20. The honeycomb structural body according to claim 19,
wherein
said through holes are alternately sealed at end portions.
21. The honeycomb structural body according to claim 19 or 20,
wherein
a catalyst is supported thereon.
22. The honeycomb structural body according to claim 19,
wherein
the average fiber length of said inorganic fibers is at least about 0.1 mm and at most about 100 mm.
23. The honeycomb structural body according to claim 22,
wherein
the average fiber length of said inorganic fibers is in the range of about 0.5 to 50 mm.
24. The honeycomb structural body according to claim 19,
wherein
the average fiber diameter of said inorganic fibers is at least about 1 μm and at most about 30 μm .
25. The honeycomb structural body according to claim 24,
wherein
the average fiber diameter of said inorganic fibers is in the range of about 2 to 10 μm .
26. The honeycomb structural body according to claim 19,
wherein
said alkali metal compound includes at least one kind selected from the group consisting of oxides of Na and oxides of K.
27. The honeycomb structural body according to claim 19,
wherein
said alkali-earth metal compound includes at least one kind selected from the group consisting of oxides of Mg, oxides of Ca and oxides of Ba.
28. The honeycomb structural body according to claim 19,

wherein
 said boron compound comprises an oxide of B.

29. The honeycomb structural body according to claim 19,
 wherein
 solubility of said inorganic fibers in physiological saline is at least about 30 ppm.

30. The honeycomb structural body according to claim 19,
 wherein
 said inorganic fibers have a function of absorbing and storing NO_x contained in an ambient gas.

31. The honeycomb structural body according to claim 19,
 wherein
 said honeycomb structural body further comprises an inorganic binder that binds the inorganic fibers to each other in addition to said inorganic fibers.

32. The honeycomb structural body according to claim 31,
 wherein
 said inorganic binder comprises least one kind selected from the group consisting of silicate glass, alkali silicate glass, borosilicate glass, alumina sol, silica sol and titania sol.

33. An exhaust gas purifying device comprising:
 a honeycomb structural body;
 a cylindrical metal shell that covers a periphery of said honeycomb structural body in the length direction; and
 a holding sealing material placed between said honeycomb structural body and said metal shell,
 wherein
 said holding sealing material mainly includes inorganic fibers comprising:
 at least about 60% and at most about 85% by weight of silica; and
 at least about 15% and at most about 40% by weight of at least one kind of compound selected from the group consisting of an alkali metal compound, an alkali-earth metal compound and a boron compound.

34. The exhaust gas purifying device according to claim 33,
 wherein
 said holding sealing material has
 a convex portion formed on one of short sides of a base material member having approximately a rectangular shape and
 a concave portion formed on the other short side
 so that said convex portion and said concave portion fit to each other when the base material member is wound around the periphery of the honeycomb structural body.

35. The exhaust gas purifying device according to claim 33,

wherein
 said inorganic fibers have a fiber tensile strength of at least about 1.2 GPa and at most about 200 GPa.

36. The exhaust gas purifying device according to claim 35,
 wherein
 said inorganic fibers have a fiber tensile strength in the range of about 1.5 to 150 GPa.

37. The exhaust gas purifying device according to claim 33,
 wherein
 the average fiber length of said inorganic fibers is at least about 0.5 mm and at most about 100 mm.

38. The exhaust gas purifying device according to claim 37,
 wherein
 the average fiber length of said inorganic fibers is in the range of about 10 to 40 mm.

39. The exhaust gas purifying device according to claim 33,
 wherein
 the average fiber diameter of said inorganic fibers is at least about 0.3 μm and at most about 25 μm .

40. The exhaust gas purifying device according to claim 39,
 wherein
 the average fiber diameter of said inorganic fibers is in the range of about 0.5 to 15 μm .

41. The exhaust gas purifying device according to claim 33,
 wherein
 said alkali metal compound includes at least one kind selected from the group consisting of oxides of Na and oxides of K.

42. The exhaust gas purifying device according to claim 33,
 wherein
 said alkali-earth metal compound includes at least one kind selected from the group consisting of oxides of Mg, oxides of Ca and oxides of Ba.

43. The exhaust gas purifying device according to claim 33,
 wherein
 said boron compound includes an oxide of B.

44. The exhaust gas purifying device according to claim 33,
 wherein
 solubility of said inorganic fibers in physiological saline is at least about 30 ppm.

45. The exhaust gas purifying device according to claim 33,
 wherein
 said inorganic fibers have a function of absorbing and storing NO_x contained in an ambient gas.

46. The exhaust gas purifying device according to claim 33, further comprising:

an organic binder that binds the inorganic fibers to each other in addition to said inorganic fibers.

47. The exhaust gas purifying device according to claim 46,

wherein

said organic binder comprises at least one kind selected from the group consisting of styrene-butadiene resins and acrylonitrile-butadiene resins.

48. The exhaust gas purifying device according to claim 46,

wherein

said organic binder has a decomposing temperature of about 200° C. or more.

49. The exhaust gas purifying device according to claim 46,

wherein

the content of said organic binder is about 10% by weight or less.

50. The exhaust gas purifying device according to claim 49,

wherein

the content of said organic binder is about 5% by weight or less.

51. The exhaust gas purifying device according to claim 49,

wherein

the content of said organic binder is about 1% by weight or less.

* * * * *