

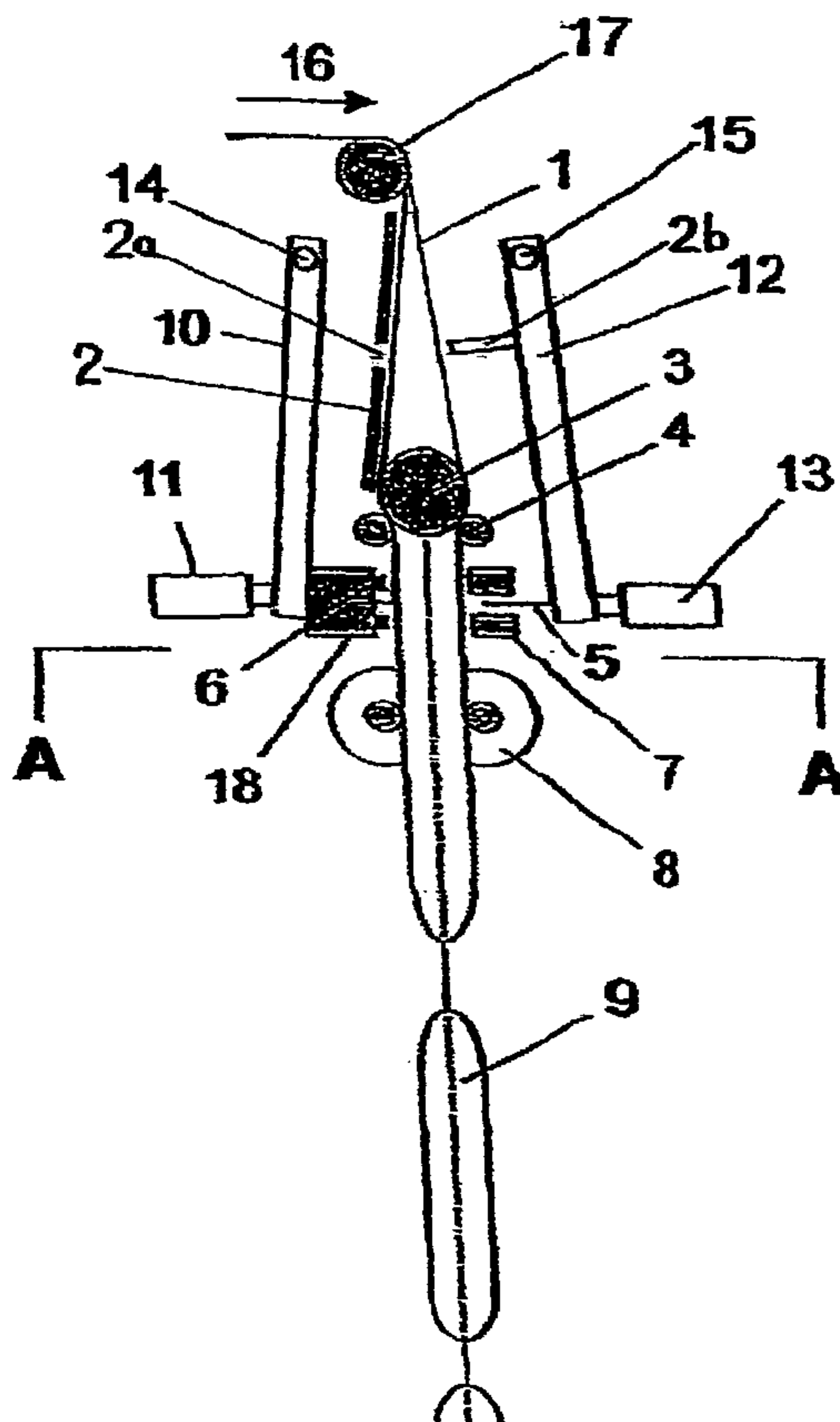

(86) Date de dépôt PCT/PCT Filing Date: 2003/01/14
 (87) Date publication PCT/PCT Publication Date: 2003/07/24
 (85) Entrée phase nationale/National Entry: 2004/07/12
 (86) N° demande PCT/PCT Application No.: CH 2003/000015
 (87) N° publication PCT/PCT Publication No.: 2003/059609
 (30) Priorité/Priority: 2002/01/17 (73/02) CH

(51) Cl.Int.⁷/Int.Cl.⁷ B31D 5/00
 (71) Demandeur/Applicant:
BORGÉAT, GUY, CH
 (72) Inventeur/Inventor:
BORGÉAT, GUY, CH
 (74) Agent: FURMAN & KALLIO

(54) Titre : MACHINE A FABRIQUER DES COUSSINS D'AIR POUR L'EMBALLAGE A PARTIR D'UN FILM TUBULAIRE
DISPOSE SUR UNE BOBINE
 (54) Title: MACHINE FOR THE PRODUCTION OF AIR PILLOWS USED FOR PACKAGING BY MEANS OF A TUBULAR
FILM DISPOSED ON A REEL



(57) Abrégé/Abstract:

Disclosed is a machine comprising a housing, means disposed inside (3) the tubular film (1) to separate the walls thereof, means (8) guiding the tubular film, and an inflating sealing device (5, 6, 7, 12). Said inflating sealing device is provided with at least one hollow needle (5) for inflating and means (2, 2a, 2b) preventing air from escaping towards said reel, i.e. upstream. Said means (2)

(57) Abrégé(suite)/Abstract(continued):

preventing air from escaping are arranged between the means disposed inside (3) said film and the reel. The inflating sealing device (5, 6, 7, 12) is arranged after the means disposed inside (3) said film and before the guiding means (8) of said film such that the tubular film (1) is pulled through the inflating sealing device. The hollow needle (5) of the inflating sealing device is fixed to a first lever arm (12) which is disposed on one side of said film and is controlled by a first actuator (13). Two heating elements (6) are positioned upstream and downstream from the needle and are fixed to a second lever arm (10) which is disposed on the other side of said film and is controlled by a second actuator (11). The means preventing the air fed into the tubular film from escaping towards said reel, i.e. upstream, comprise an elongate element (2b) which extends in a transversal direction relative to the film (1) and is fixed to said first lever arm (12) such that said elongate element (2b) is kept away from the film during movement thereof and is inserted into a slot (2a) arranged in a plate (2) of the machine housing and pushes said film into the slot, creating a narrow fold thereon.

(12) DEMANDE INTERNATIONALE PUBLIÉE EN VERTU DU TRAITÉ DE COOPÉRATION
EN MATIÈRE DE BREVETS (PCT)(19) Organisation Mondiale de la Propriété
Intellectuelle
Bureau international(43) Date de la publication internationale
24 juillet 2003 (24.07.2003)

PCT

(10) Numéro de publication internationale
WO 03/059609 A1

(51) Classification internationale des brevets⁷ : B31D 5/00 (25) Langue de dépôt : français

(21) Numéro de la demande internationale : PCT/CH03/00015 (26) Langue de publication : français

(22) Date de dépôt international : 14 janvier 2003 (14.01.2003) (30) Données relatives à la priorité : 73/02 17 janvier 2002 (17.01.2002) CH

[Suite sur la page suivante]

(54) Title: MACHINE FOR THE PRODUCTION OF AIR PILLOWS USED FOR PACKAGING BY MEANS OF A TUBULAR FILM DISPOSED ON A REEL

(54) Titre : MACHINE A FABRIQUER DES COUSSINS D'AIR POUR L'EMBALLAGE A PARTIR D'UN FILM TUBULAIRE DISPOSE SUR UNE BOBINE

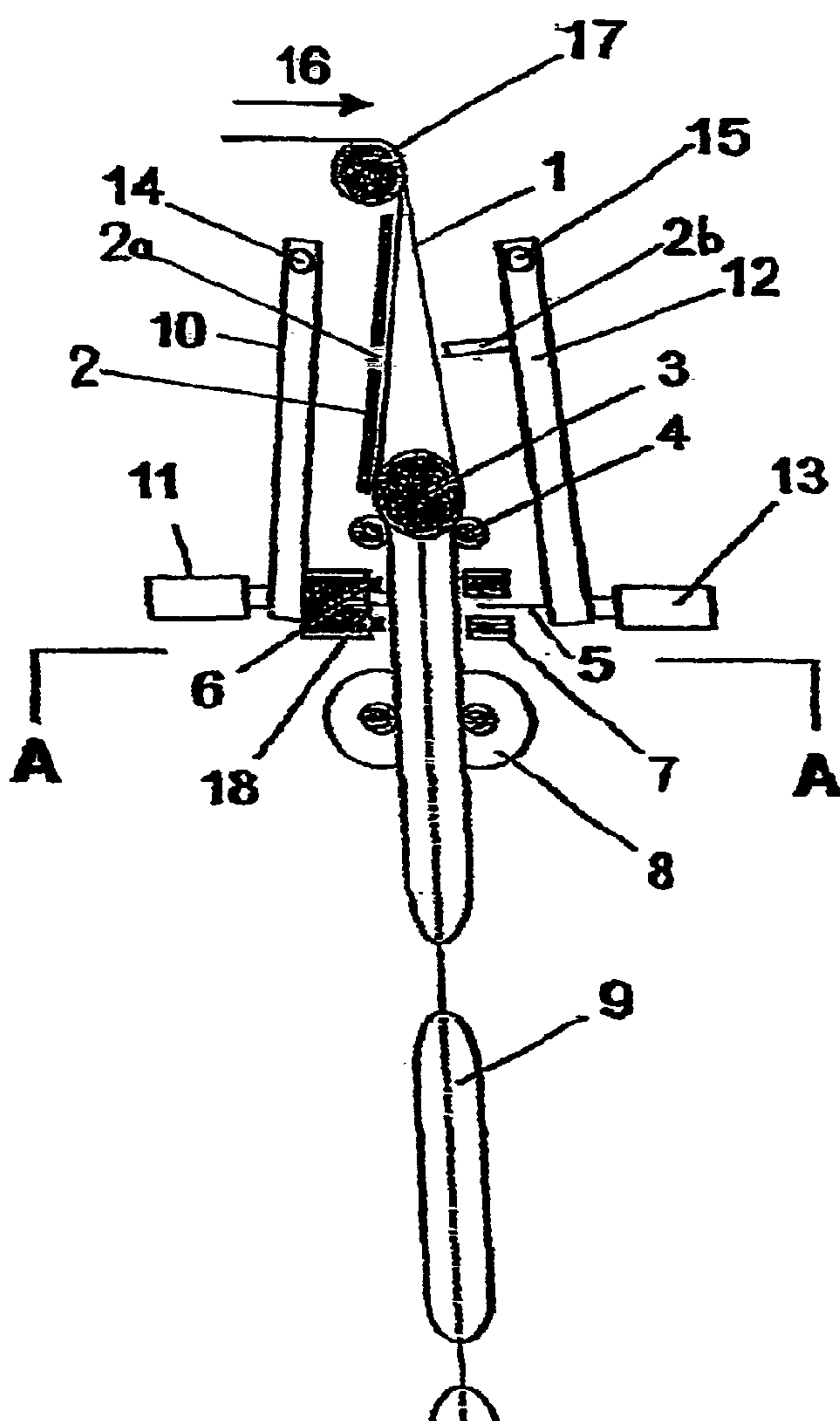

(57) Abstract: Disclosed is a machine comprising a housing, means disposed inside (3) the tubular film (1) to separate the walls thereof, means (8) guiding the tubular film, and an inflating sealing device (5, 6, 7, 12). Said inflating sealing device is provided with at least one hollow needle (5) for inflating and means (2, 2a, 2b) preventing air from escaping towards said reel, i.e. upstream. Said means (2) preventing air from escaping are arranged between the means disposed inside (3) said film and the reel. The inflating sealing device (5, 6, 7, 12) is arranged after the means disposed inside (3) said film and before the guiding means (8) of said film such that the tubular film (1) is pulled through the inflating sealing device. The hollow needle (5) of the inflating sealing device is fixed to a first lever arm (12) which is disposed on one side of said film and is controlled by a first actuator (13). Two heating elements (6) are positioned upstream and downstream from the needle and are fixed to a second lever arm (10) which is disposed on the other side of said film and is controlled by a second actuator (11). The means preventing the air fed into the tubular film from escaping towards said reel, i.e. upstream, comprise an elongate element (2b) which extends in a transversal direction relative to the film (1) and is fixed to said first lever arm (12) such that said elongate element (2b) is kept away from the film during movement thereof and is inserted into a slot (2a) arranged in a plate (2) of the machine housing and pushes said film into the slot, creating a narrow fold thereon.

[Suite sur la page suivante]

WO 03/059609 A1

Abstract

This machine comprises a frame, spacing means arranged in the interior (3) of the tubular film (1) to separate the walls, traction means (8) to draw the tubular film and an inflating and welding device (5, 6, 7, 12). The inflating and welding means is provided with at least one hollow needle (5) for inflation, means (2, 2a, 2b) to prevent the air escaping toward said reel, that is to say, upstream. Said means (2) to prevent the escape of air are placed between the means (3) provided within the said film and the reel. The inflating and welding device (5, 6, 7, 12) is located after the means (3) provided within said film and before the traction means (8) for drawing said tubular film (1) through the inflating and welding device. The hollow needle (5) of the inflating and welding device is attached to a first beam (12) located on one side of the said film and controlled by a first actuator (13) and two heating elements (6) located upstream and downstream of the hollow needle attached to a second beam (10) located on the other side of said film controlled by a second actuator (11). The means for preventing the air introduced into the tubular film from escaping towards the said reel, that is to say, upstream, comprise an elongate element (2b) extending in a transverse direction relative to the film (1) attached to said first beam (12) in such a way as to be held away from said film during the movement of the latter and being introduced into a recess (2a) provided in a plate (2) on the frame of the machine to force said film into the recess to form a sealed fold in the latter.

Machine for making air cushions for packaging from a tubular film wound on a reel

The present invention has for an object a machine for making air cushions for packaging from a tubular film wound on a reel, notably for cushioning delicate and fragile objects.

The document WO 99/61232 contains a history of the improvements made to the types of machine which form the subject of the present invention and defines a machine for making air cushions for packaging which do not exhibit the defects of the prior art. However, the machine defined in document WO 99/61232 still has some problems, particularly in relation to the tension of the tubular film intended for making the air cushions. This tension is very important for allowing good perforation of the film and hence a standard filling of the cushions.

The invention has for an object to provide a machine intended for the manufacture of air cushions for packaging which represents a marked improvement over the known machines, particularly in respect of the tension of the film, so as to ensure reliable operation of the machine in respect of both quality and durability.

These goals are achieved with the machine for making air cushions for packaging from tubular film wound on a reel in accordance with the invention, said machine comprising a frame, spacing means arranged within said tubular film to separate the walls, traction means to draw the tubular film and an inflating and welding device having at least one hollow needle for inflation, means to prevent the air escaping toward said reel, that is to say, upstream, said means to prevent the escape of air being placed between the means provided within the said film and the reel, the inflating and welding device being placed after the means provided within said film and before the means for drawing said film to pull the tubular film through the inflating and welding device, the hollow needle of the inflating and welding device being attached to a first beam located on one side of the said film controlled by a first actuator and two heating elements located upstream and downstream of the hollow needle on a second beam located on the other side of said film controlled by a second actuator, characterised in that the means for preventing the air introduced into the tubular film from escaping towards the said reel, that is to say, upstream, comprise an elongated element extending in a transverse direction relative to the film attached to said first beam in such a way as to be held away from said film during the movement of the latter and being introduced into a recess provided in a plate in the frame of the machine to force said film into the recess to form a sealed fold in the latter.

The invention will be better understood and its advantages will appear more clearly from a reading of the description of the method of carrying the invention into effect, which is given solely by way of example, and by means of the drawings in which:

figure 1 represents a schematic view of a machine in accordance with the invention,
figure 2 shows the section A-A of figure 1 showing the traction device as seen from above,
figures 3 a, b and c provide a diagrammatic representation of the different phases of operation of the machine shown in figure 1.

As can be seen from the schematic view of figure 1, one embodiment of the machine in accordance with the invention includes means 8 to draw the tubular film 1, which can be of any material which can be welded by thermal welding, for example, plastic. The film is pulled in the direction of the arrow 16 from a reel, which is not shown. The film 1 first passes over a return roller 17 which displaces it vertically on the drawing, then it passes in front of a plate 2 on the frame comprising a recess 2a. The recess 2a in the plate 2 is arranged opposite an elongate element 2b attached to a first beam 12. The tubular film 1 then encounters a body 3 introduced into the interior of the tubular film 1 through the opening at the end of the film 1 at the time when the machine is first started up. The body 3 rests on two bars or rods 4 disposed outside said film 1 and separated by a distance less than the external diameter of the body 3. The body 3 is, for example, a cylinder of plastic material of about 1 cm in diameter, held in place solely by gravity on the two rods 4. Just after its passage around the body 3 the film 1 passes through the inflating and welding device.

The inflating and welding device comprises at least one hollow needle 5 connected to inflating means (for example, a compressor, not shown) and fixed to a first beam 12 articulated on an axis 15 and thermal pressure welding means 6 attached to a second beam 10 articulated on an axis 14. The oscillating movement of the beam 12 is controlled by a first actuator 13 and the oscillating movement of the beam 10 by a second actuator 11.

The welding means 6 consist of two heating bars (for example, using thermal resistance) disposed one above the other, of a length at least equal to the width of the tubular film 1 and placed on one side of said film opposite thrust bars 7 placed one above the other on the opposite side, the hollow needle 5 being arranged between thrust bars 7. The inflating and welding device also comprises points or a serrated knife 18 between the heating bars to perforate or partially cut the tubular film 1 in order to facilitate its separation.

In figure 2 the film traction device 8 comprises two cylinders 19, 19a each having ends of greater diameter than that of their central parts 20, 20a. The terminal parts of the cylinders 19, 19a are

coated with flexible and elastic material, for example, foam rubber. Cylinders 19, 19a are in contact with one another at their extremities leaving in their central part a space such that the two walls of the tubular film 1 can remain separated after inflation. The two cylinders are caused to rotate by a motor 23 by means of gears 24 and 21.

The operation of the machine will be explained with the aid of figures 3a, 3b and 3c. The elements represented are the same as those of figure 1; the reference symbols have not been repeated in order not to obscure the drawings. First, the body 3 is introduced through the opening of the end of the said tubular film into the interior of the latter and the film is drawn between the bars 4, then through the driving means 8. The welding device 6, 7 is then operated so as to close the end of the tubular film 1 by means of a weld 29 (Fig. 3). The machine is ready to operate, as shown in figure 3a. The actuator 13 operates the beam 12 so as to displace the element 2b in the direction of the arrow 31 which enters into the recess 2a in the plate 2 of the frame of the machine. The element 2b comprises a strip having a thickness substantially less than the opening of the recess 2a so that the strip can introduce the two walls of the tube 1 into the recess 2a. When the film 1 is introduced into the recess 2a it creates a tension on the latter. In effect, the film 1 is retained on the roller 17 and in the traction device 8, this tension improves the separation of the two walls of the tubular film 1.

Immediately after the element 2b has been introduced into the recess 2a, the needle 5 is introduced in the direction of the arrow 27 (figure 3b) into the tubular film 1 by the movement of the beam 12 effected by the actuator 13, penetrating only one wall because the region where it is introduced is immediately after the body 3 and walls of the tubular film have been well separated. Inflation is then effected, air being retained by the weld 29 and by the fold formed in the recess 2a in the plate 2 by the element 2b.

Welding is then effected, the welding bars 6 being displaced in the direction of the arrow 28 (figure 3c) by the beam 10 moved by the actuator 11 so as to come to rest on the thrust bars 7 pinching the tubular film between them and the thrust bars. Welding can then take place. The welding bars are then heated in order to effect sealing of the two walls of the tubular film to form a cushion 30. During the welding, the needle 5 and the element 2b are withdrawn rearwards by a reverse movement of the beam 12 effected by the actuator 13. The welding bars are then withdrawn rearwards by a reverse movement of the beam 10 effected by the actuator 11. The cushion 30 is then pulled on its sides by cylinders 8 as indicated in figure 2 for a distance equal to the length of a cushion.

The cycle described above can then restart because it is again in the position shown in figure 3a.

It is to be understood that the description of the method of carrying the invention into effect given above is provided only by way of example. Thus all the variations relating to the shape of the element intended to enter the recess to hold the film are comprised within the scope of the present invention.

Claims

1. Machine for making air cushions for packaging from a tubular film (1) arranged on a reel, said machine comprising a frame, means provided inside (3) said tubular film to separate the walls thereof, traction means (8) for pulling the tubular film and an inflating and welding device (5, 6, 7, 12) having at least one hollow needle (5) for the inflation, means (2, 2a, 2b) to prevent air from escaping towards said reel, that is to say, upstream, said means (2) to prevent air escaping being located between the spacing means (3) provided within the said film and the reel, the inflating and welding device (5, 6, 7, 12) being located after the means (3) located in the interior of said film and before the means (8) for pulling said film (1) so as to pull the tubular film through the inflating and welding device, the hollow needle (5) of the inflating and welding device being attached to a first beam (12) located on one side of said film and operated by a first actuator (13), and two heating elements (6) placed upstream and downstream of said needle attached to a second beam (10) disposed on the other side of said film and operated by a second actuator (11), characterised in that the means for preventing the escape of air introduced into the tubular film towards said reel, that is to say, upstream, comprise an elongate element (2b) extending in a transverse direction relative to the film (1) attached to said first beam (12) in such a way as to be held away from said film while the latter is being moved and introduced into a recess (2a) provided in a plate (2) on the frame of the machine to force said film into the recess to form a sealed fold in the latter.

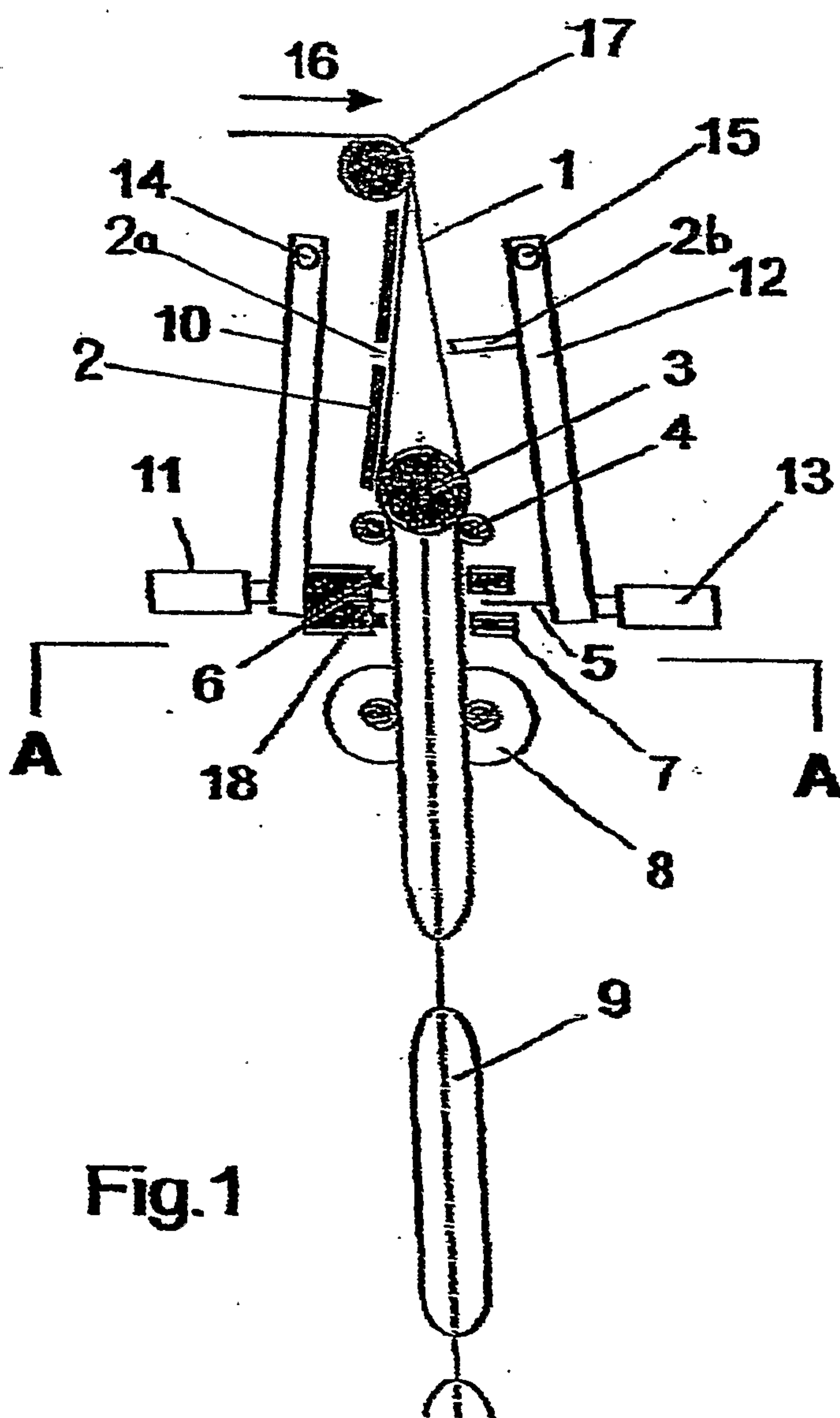

Fig.1

Fig. 2

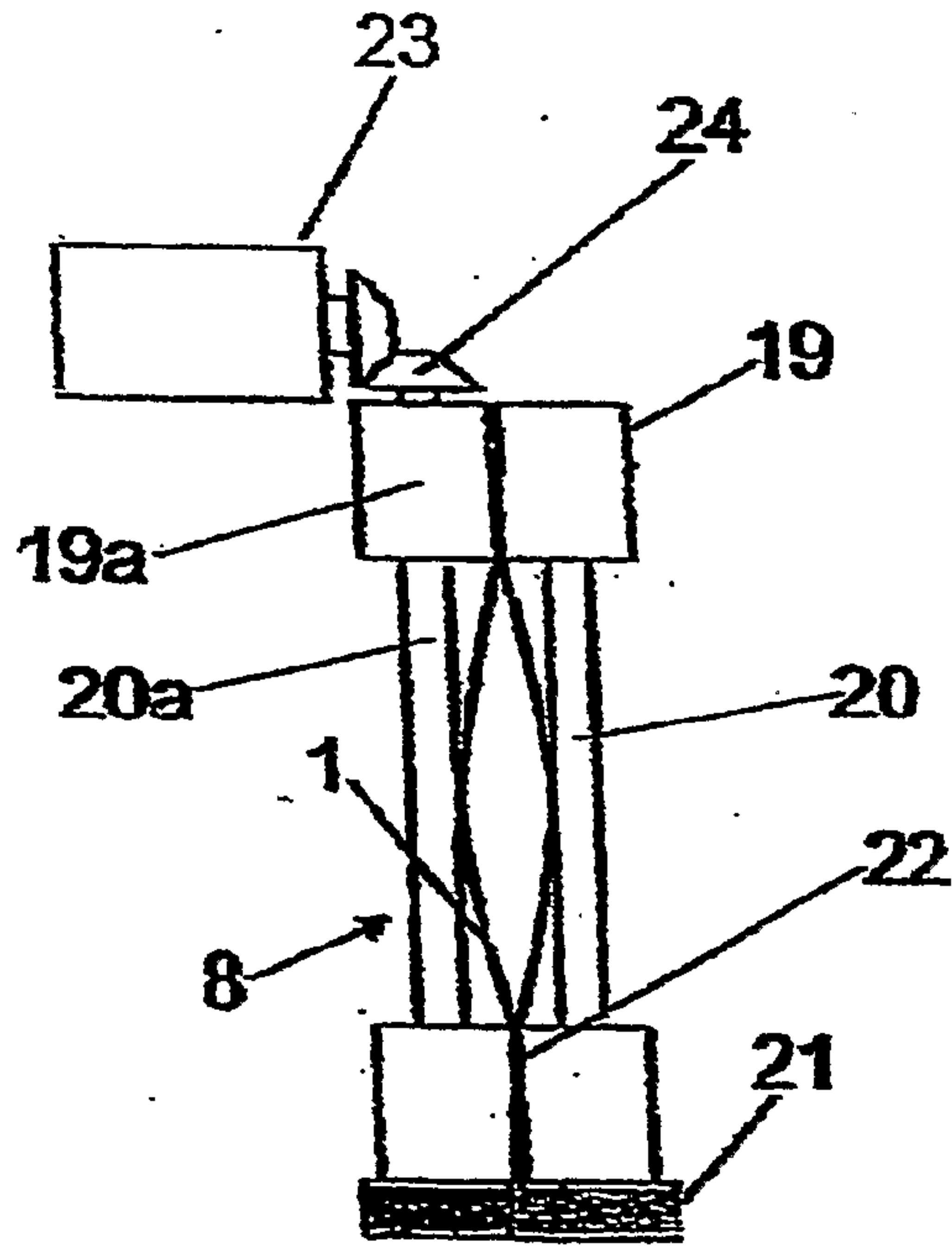
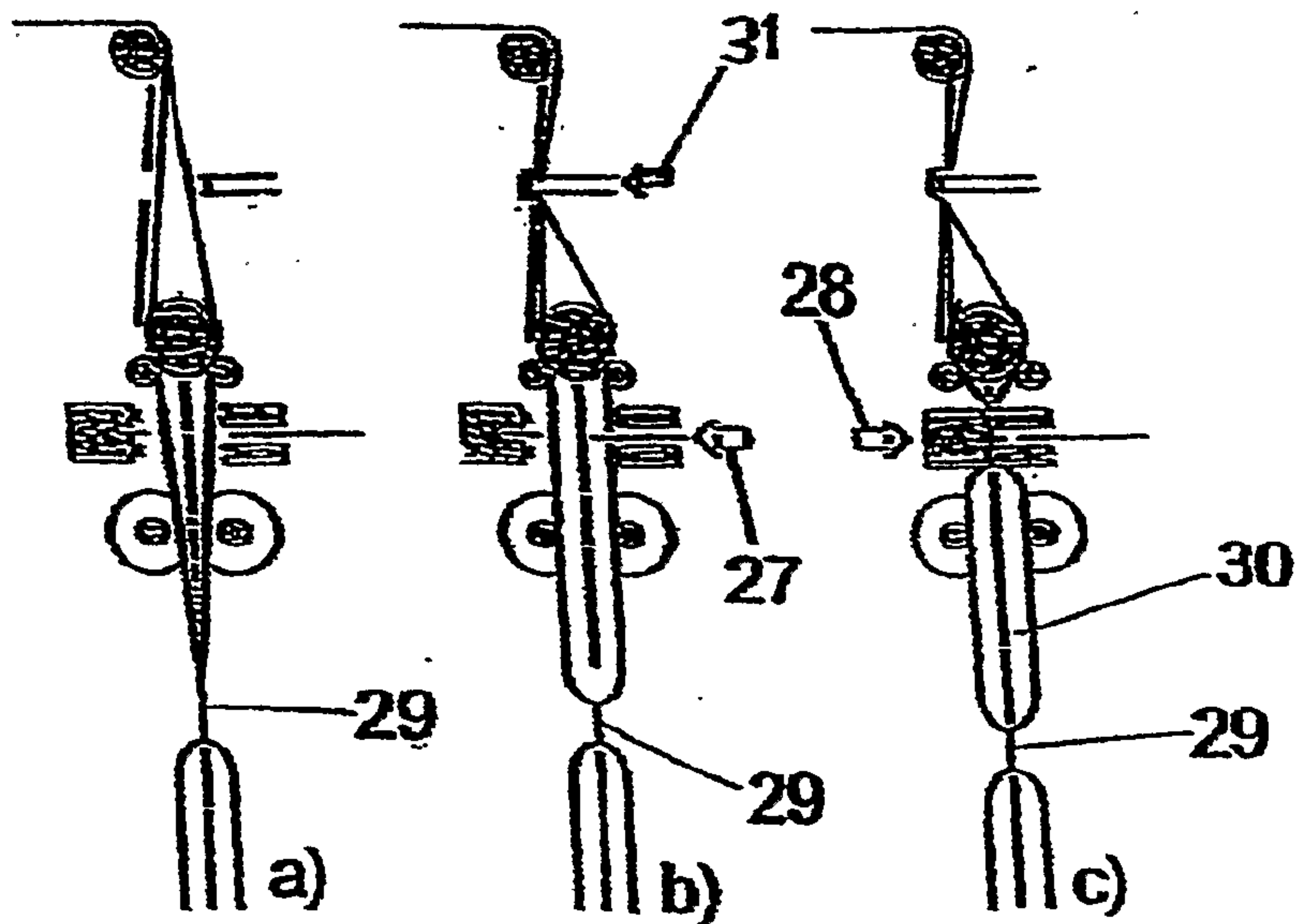

Fig. 3



ERSATZBLATT (REGEL 26)

