

(12) **UK Patent Application** (19) **GB** (11) **2 369 404** (13) **A**

(43) Date of A Publication 29.05.2002

(21) Application No 0202069.1

(22) Date of Filing 05.05.1999

Date Lodged 30.01.2002

(30) Priority Data

(31) GB9809640.7 (32) 06.05.1998 (33) GB

(62) Divided from Application No 9910198.2 under Section 15(4) of the Patents Act 1977

(51) INT CL⁷

E05B 65/12

(52) UK CL (Edition T)

E2A AARN

(56) Documents Cited

WO 98/05840 A1

(58) Field of Search

UK CL (Edition T) E2A AARN

INT CL⁷ E05B 65/12 65/32

Online: EPODOC, JAPIO, WPI

(71) Applicant(s)

Meritor Light Vehicle Systems (UK) Limited
(Incorporated in the United Kingdom)
Fordhouse Lane, Stirchley, BIRMINGHAM,
West Midlands, B30 3BW, United Kingdom

(74) Agent and/or Address for Service

Withers & Rogers
Goldings House, 2 Hays Lane, LONDON, SE1 2HW,
United Kingdom

(72) Inventor(s)

Gurbinder Singh Kalsi

(54) Abstract Title

Latch mechanism with alternate operating modes

(57) A latch mechanism 10 having a set of operating modes, each mode having alternate states, the set including at least two of a lock mode and a super lock mode, a child safety mode and release mode, changing of the latch mechanism between alternate states of each of the at least two modes of the set being effected by a single power actuator (not shown), wherein a cam 30 is driven by the actuator to select the states.

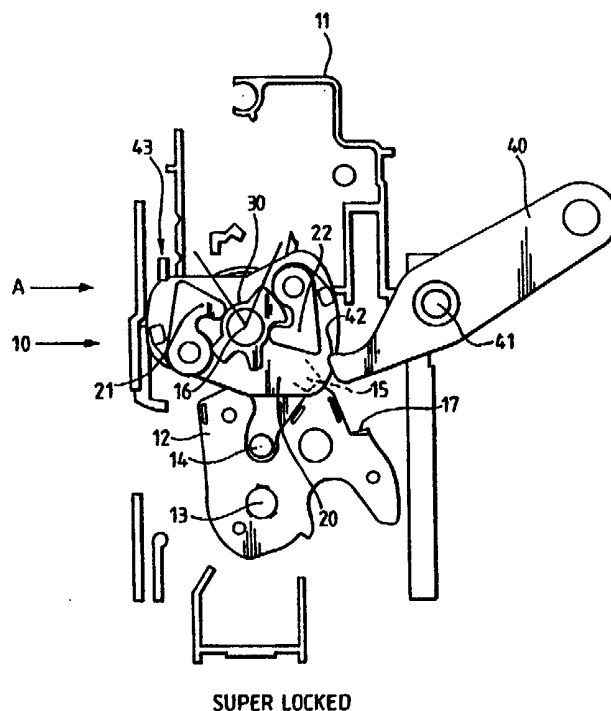
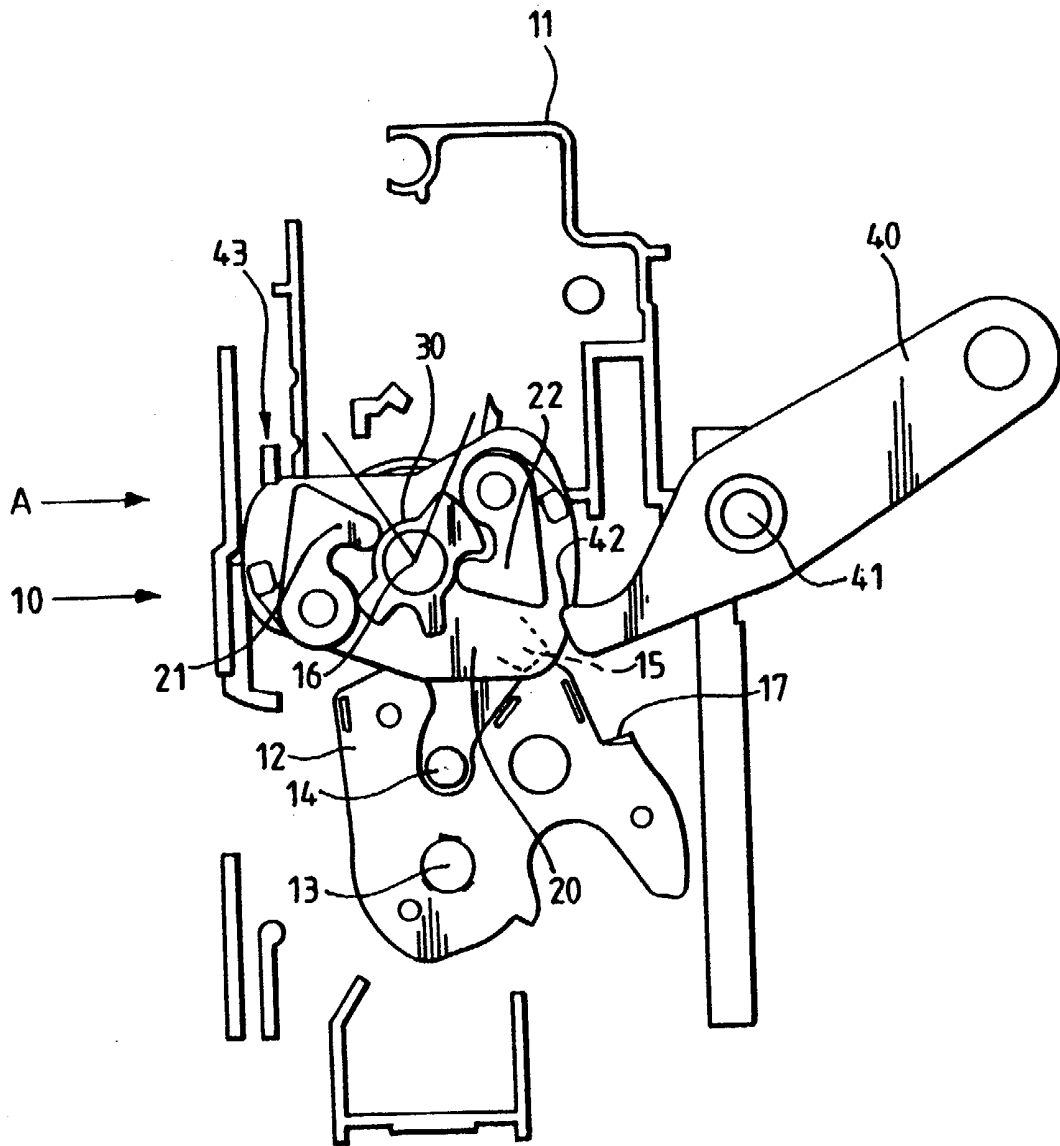

FIG.1.



SUPER LOCKED

FIG.1.

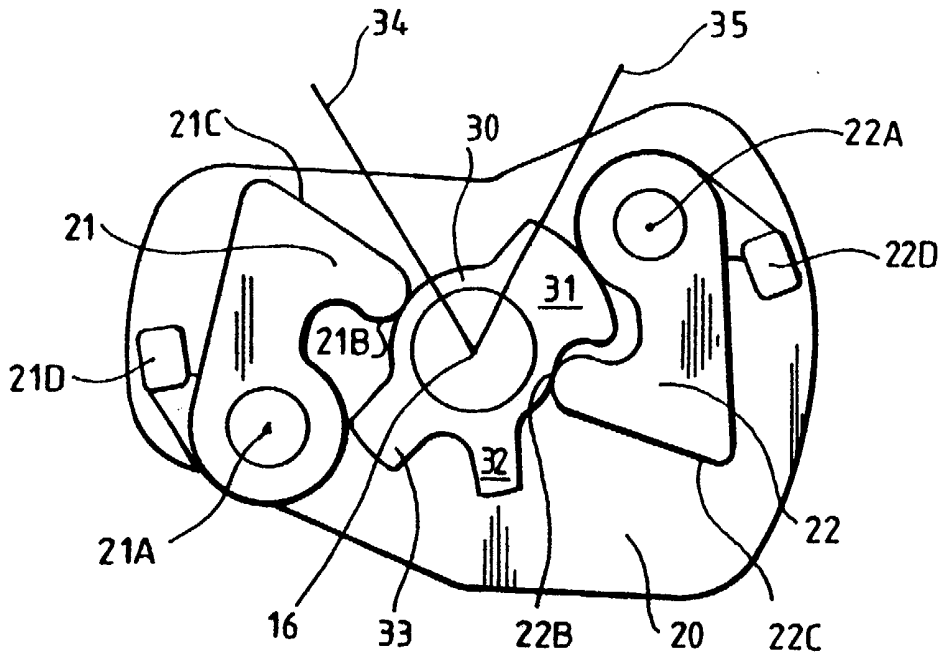

FIG. 1A.

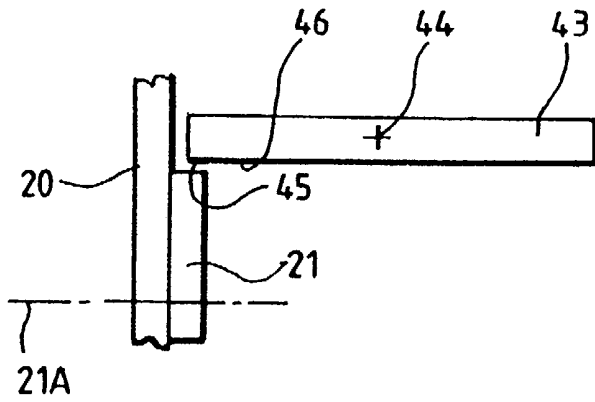
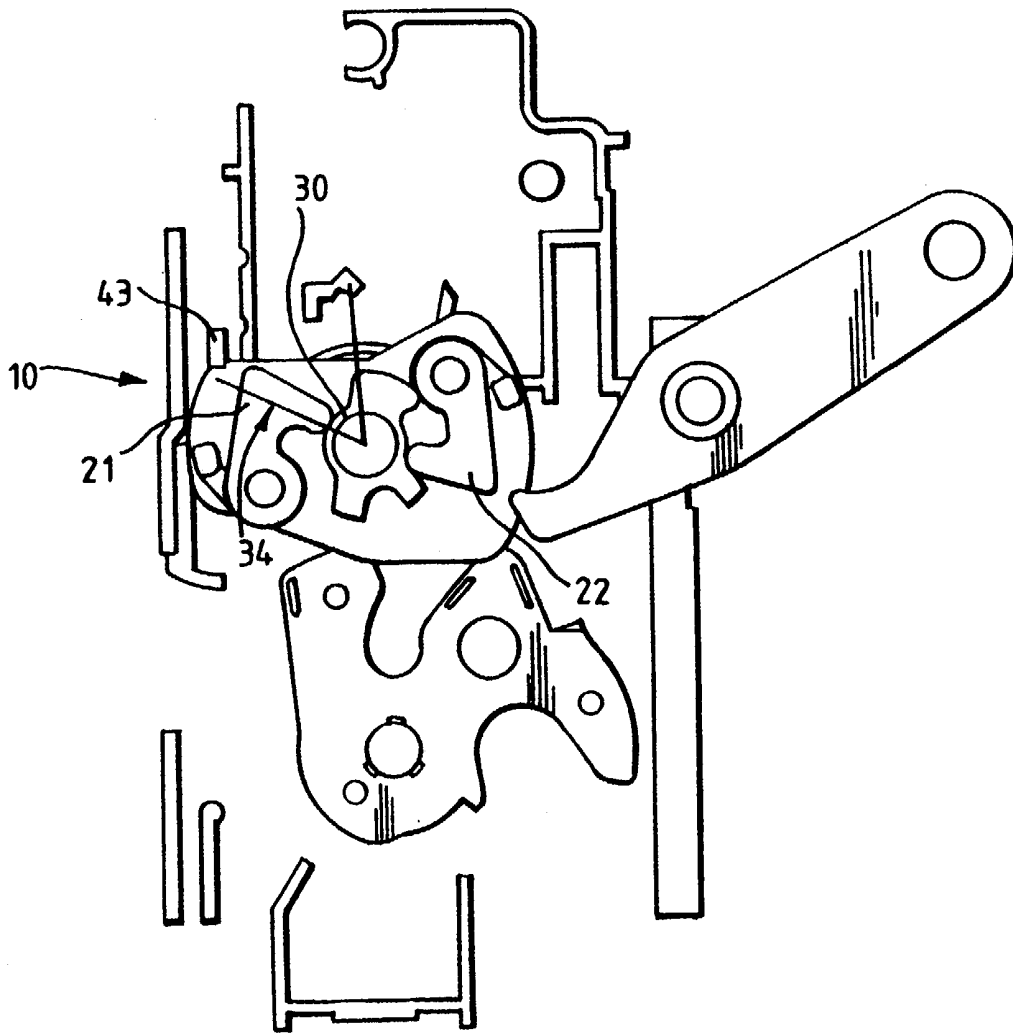
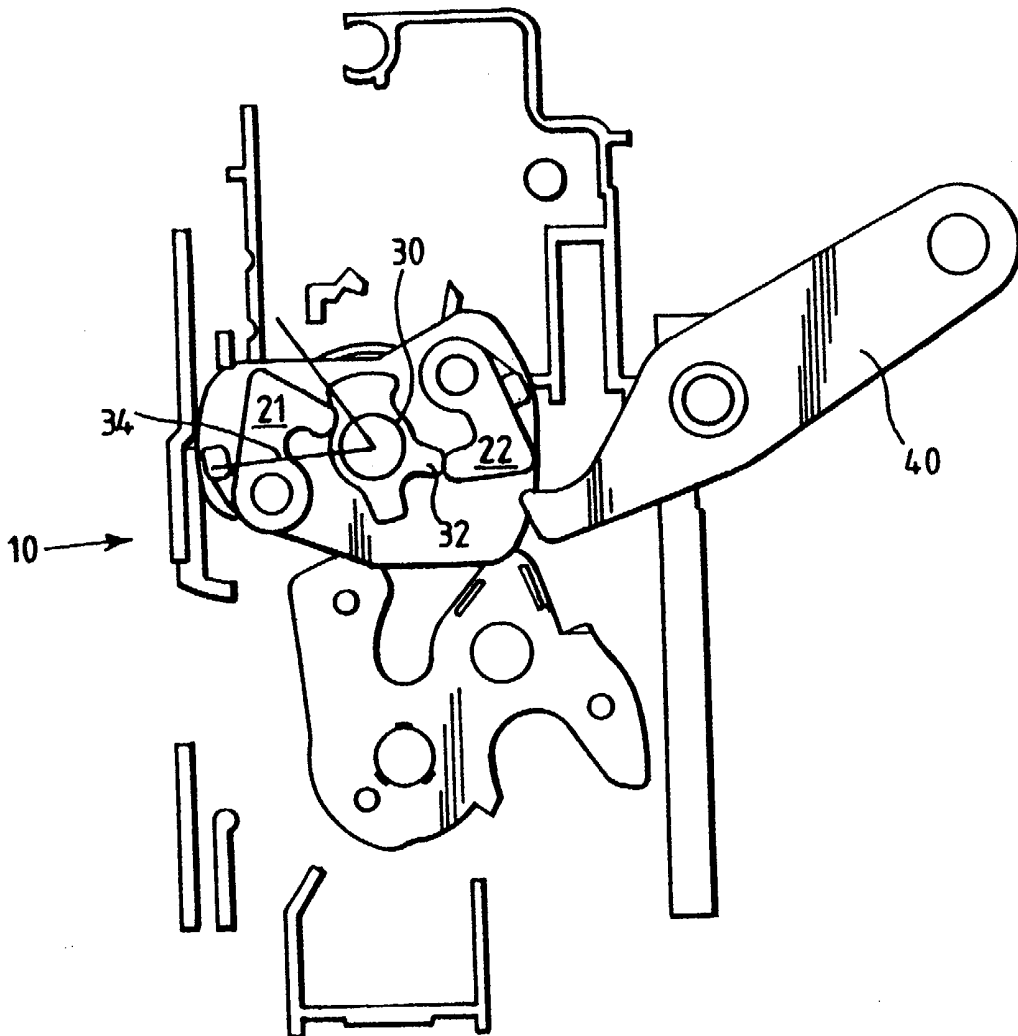

FIG. 1B.



LOCKED - CHILD SAFETY ON

FIG. 2.



UNLOCKED - CHILD SAFETY ON

FIG. 3.

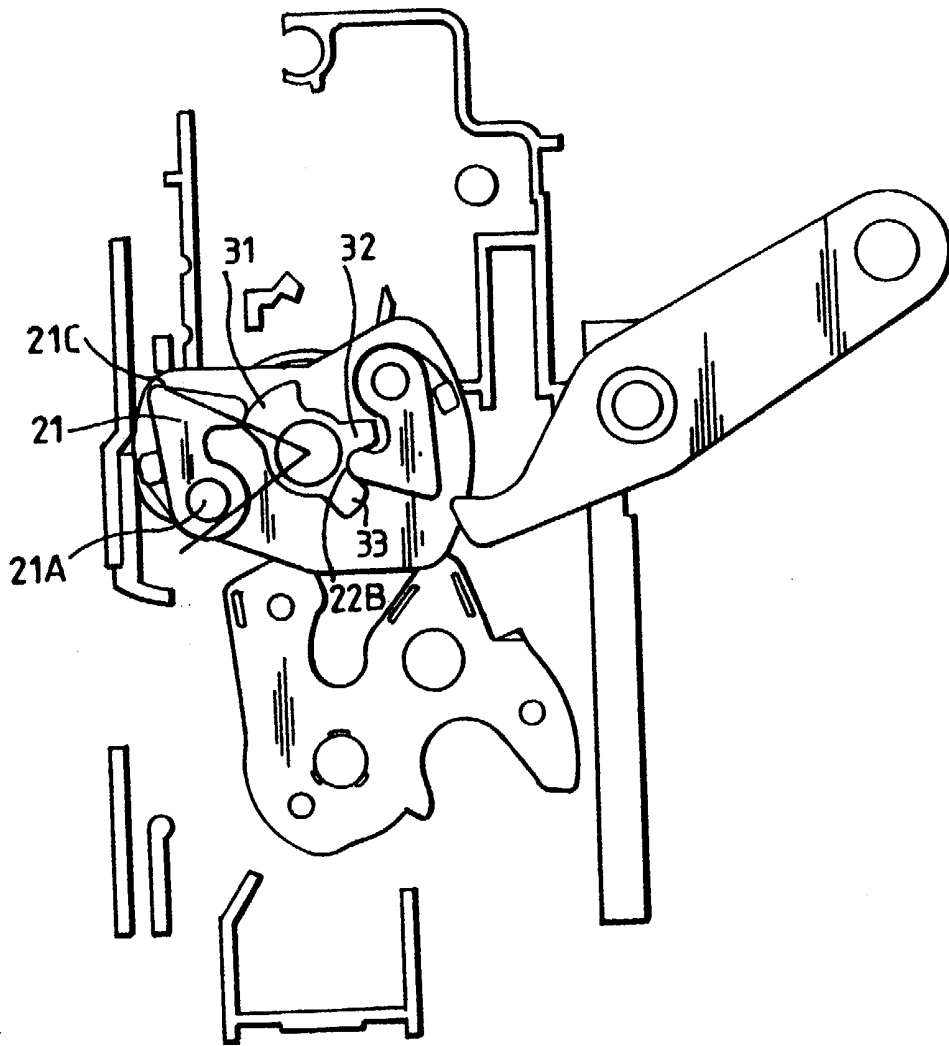

LOCKED CHILD SAFETY OFF

FIG. 4.

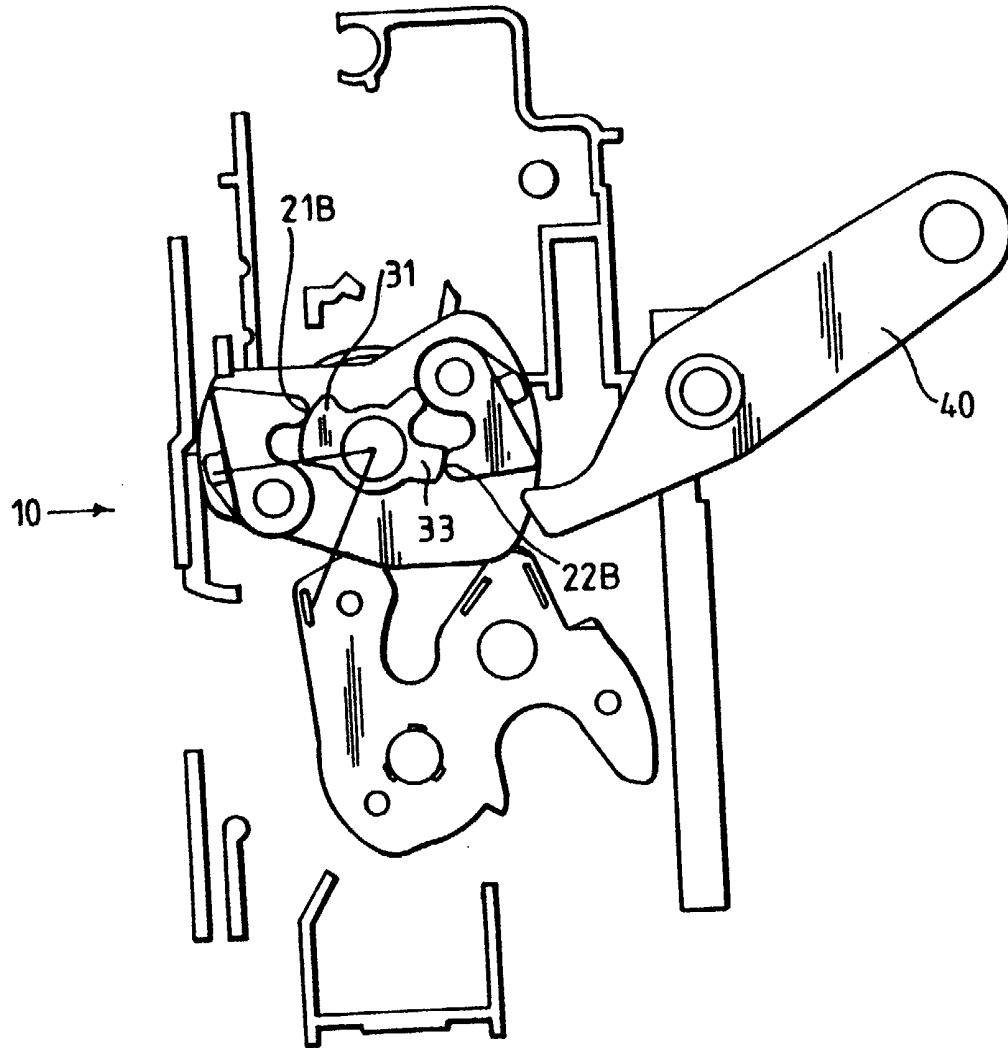

UNLOCKED CHILD SAFETY OFF

FIG. 5.

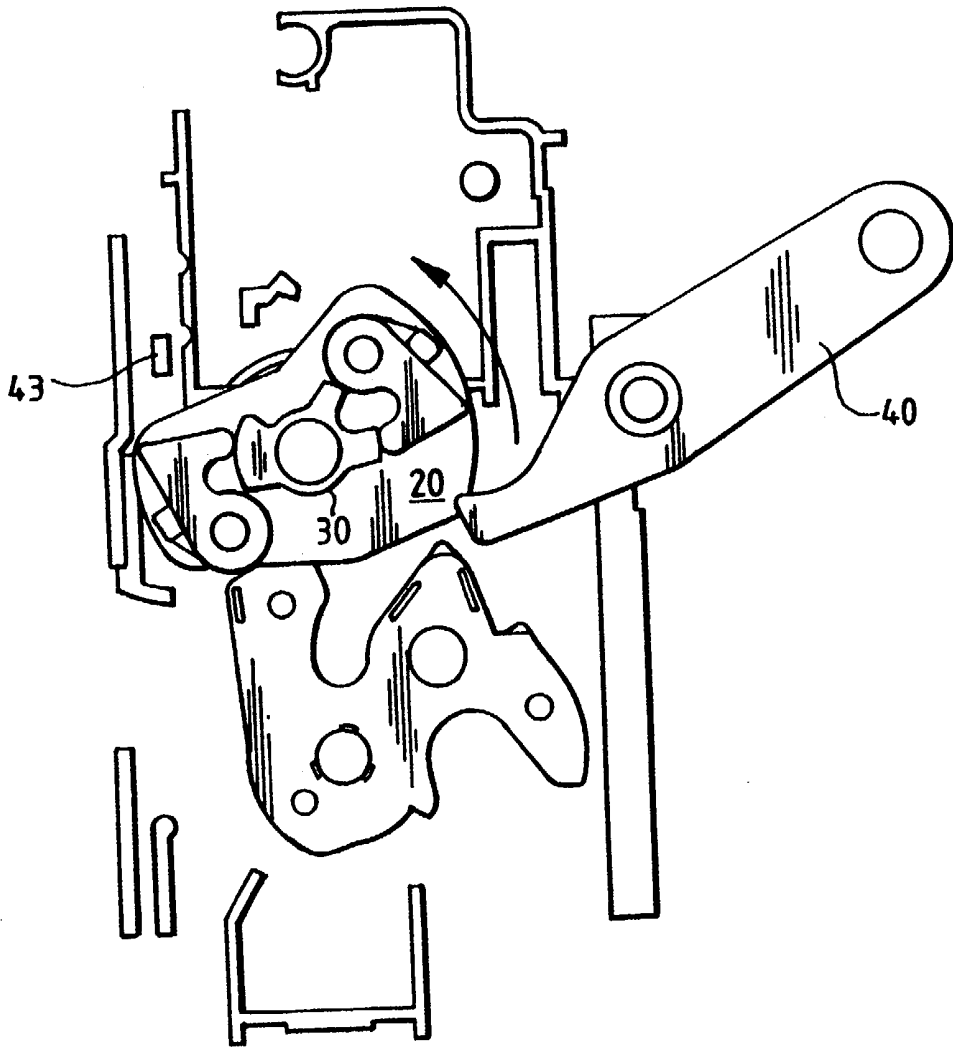

RELEASE

FIG. 6.

Latch Mechanism

The present invention relates to latch mechanisms for doors of vehicles. The invention further relates to vehicles including at least 2 doors, each door incorporating a latch mechanism.

It is known to provide latch mechanisms on doors of vehicles to allow opening and closing of the door. Such latch mechanisms have various modes of operation e.g.

10 a) Lock mode, wherein operation of an outside door handle does not open the latch mechanism

(b) Superlocked mode, when in operation of an outside or an inside release lever does not operate the latch mechanism.

15

(c) Child safety mode, wherein operation of an inside release lever does not open the latch mechanism, whether or not the latch mechanism is locked, and

(d) Release mode, wherein the latch mechanism is released via means other than operation of the inside or outside release levers.

20

Each mode has alternate states eg locked/unlocked, superlocked/notsuperlocked, child safety on/off and release/not released.

25

30

Typically each mode requires an individual mechanism to effect the alternative states, with operation of each mechanism being affected either manually or with an individual power actuator.

5

In the case of a latch mechanism operated entirely by power actuators such as DC motors, it is also necessary to be able to open a locked door which has the child safety feature on in an emergency situation when actuation of the power actuators is not possible, such as when the keys to the vehicle are not available.

10

Thus according to the present invention there is provided a latch mechanism including a housing, a pawl movably mounted in the housing to release the latch, with at least one of an inside and outside lock link mounted for movement with the pawl with the at least one lock link being movable between a first position at which operation of an associated release means causes movement of the pawl to release the latch, and a second position at which operation of the associated release means does not cause movement of the pawl.

20

Preferably movement of the at least one lock link between its first and second position is effected by a power actuator.

According to a further aspect of the invention there is also provided a latch mechanism having a set of operating modes, each mode having alternate states, the set including at least one of a lock mode and a super lock mode, and at least one of a child safety mode and a release mode, changing of the latch mechanism between alternative states of each of the at least two modes of the set being effected by a single power actuator.

30 According to a further aspect of the invention there is provided a latch mechanism having a set of operating modes, each mode having alternate states, the set including a

child safety mode and a release mode, changing of the latch mechanism between alternate states of each of the modes being effected by a single power actuator.

5 According to a further aspect of the present invention there is provided a vehicle including a first and second door, each door including respective first and second latch mechanisms, the first and second latch mechanisms being substantially the same, and being operable by respective first and second power actuators to give respective first and second sets of operating modes, each mode having alternate states, control of the power actuators being different to provide for different first and second sets of
10 operating modes.

The invention will now be described by way of example only with reference to the accompanying drawings in which:

15 FIGURE 1 is a latch mechanism according to the present invention in a super-locked condition;

FIGURE 1a is an enlarged view of part of Figure 1;

20 FIGURE 1b is a schematic view in the direction of arrow A of Figure 1;

FIGURE 2 is the latch mechanism of Figure 1 in a locked position with child safety on;

25 FIGURE 3 is the latch mechanism of Figure 1 in an unlocked condition with the child safety on;

FIGURE 4 is the latch mechanism of Figure 1 in a locked condition with the child safety off;

30 FIGURE 5 is the latch mechanism of Figure 1 in an unlocked position with the child safety off; and

FIGURE 6 is a latch mechanism of Figure 1 in a release position.

With reference to Figures 1 to 6 there is a latch mechanism 10 including a body 11 which supports various components of the latch mechanism 10 as indicated below.

5

Latch mechanism 10 further includes a claw 12 pivotally mounted about axis 13 on the body 11. Claw 12 acts to secure an associated door (not shown) in a closed position via a striker pin 14 attached to the door aperture. Rotation of the claw 12 in an anticlockwise direction about axis 13 when viewing Figure 1 allows release of the
10 striker pin 14, thus enabling opening of the associated door.

The claw 12 is held in a closed position by a pawl 15, only part of which is shown in dotted profile in Figure 1 for clarity. Pawl 15 is pivotally mounted on body 11 and can rotate about axis 16. Claw 12 can be held in a first safety position (not shown) when
15 pawl 15 engages first safety abutment 17.

Pawl lifter 20 is generally flat and lies in a plane parallel to pawl 15, to which it is rotationally secured. When viewing Figure 1 pawl 15 is obscured by pawl lifter 20. Clearly, pawl lifter 20 also rotates about axis 16.

20

Inside lock link 21 and outside lock link 22 are mounted for movement with the pawl, in this case they are each individually pivoted about respective axes 21a and 22a on pawl lifter 20. In this case inside lock link 21 and outside lock link 22 are identical and each have respective cam followers 21b and 22b and release abutments 21c and 22c.

25

Inside lock link 21 and outside lock link 22 are each biased in a clockwise direction when viewing Figure 1 such that the respective cam followers 21b and 22b contact cam
30.

30

Cam 30 is capable of rotating independently from pawl lifter 20 about axis 16. Cam 30 has three lobes 31, 32, and 33 and two levers 34 and 35 shown diagrammatically for clarity. Lobes 31, 32, 33 and levers 34 and 35 are all rotationally fast with cam 30.

Preferably cam 30 can at least be rotated to the various positions as described below by a power actuator (not shown) such as a DC motor or preferably a stepper motor.

5 Outside release lever 40 is pivotally mounted about axis 41. Inside release lever 43 (shown diagrammatically in Figure 1b) is pivotally mounted about axis 44.

Operation of a door latch mechanism is as follows.

Figure 1 shows the door latch mechanism in a super lock condition, that is to say
10 operation of the outside release lever 40 or inside release lever 43 does not allow unlatching of the mechanism. In particular it can be seen that if outside release lever 40 were to be operated by being rotated in a clockwise direction about axis 41, abutment 42 would pass release abutment 22c of outside lock link without contact (note that outside release lever 40 is in the same plane as outside lock link 22). Similarly inside
15 release lever 43 when operated by being rotated in an anticlockwise direction about axis 44 when viewing Figure 1b, would cause abutment 45 to pass release abutment 21c of inside lock link 21 (see especially Figure 1).

Figure 2 shows the door latch mechanism 10 in a locked position with the child safety
20 feature on. It will be noted that cam 30 has been rotated 30 degrees in an anticlockwise direction when compared to Figure 1. However, the inside lock link 21 and outside lock link 22 are in the same position when compared with Figure 1 since neither of the cam followers 21b or 22b have, at this stage, ridden up any of the lobes 31, 32 or 33 or the cam 30. However, lever 34 has been rotated to a position whereby operation of the
25 inside release lever 43 in an anticlockwise direction when viewing Figure 1b would cause abutment 46 to contact lever 34 and rotate cam 30 to the position shown in Figure 3. Note this initial operation of inside release lever 43 does not unlatch the mechanism but only operates to unlock the door (see below). This method of being able to override and open a locked door which has the child safety on is especially important in an
30 emergency situation whereby a passer-by can effect access to the inside door handle (eg by breaking the door window glass), operate the inside door handle to unlock the door,

then operate the outside door handle to open the door and then remove the child from the car.

Figure 3 shows the door latch mechanism 10 in an unlocked condition with the child safety feature on. In this case the cam 30 has been rotated sufficiently (either by operating the inside release lever when the cam was in the position shown in Figure 2 or by independent rotation of the cam directly eg by a power actuator) such that cam follower 22b has ridden up cam lobe 32 resulting in anticlockwise rotation of outside lock link 22. Thus when outside release lever 40 is operated, abutment 42 contact release abutment 22c causing the pawl lifter 20 as a whole to rotate anticlockwise when viewing Figure 3 and releasing the pawl 15 and allowing the claw 12 to open. Stop 22d limits the anticlockwise rotation of outside lock link 22. Upon release of the outside release lever 40 the pawl lifter 20 is biased back to the position as shown in Figure 3 by a spring (not shown). It should also be noted that the inside lock link 21 is in the same position as that shown in Figure 1, thus operation of the inside release lever 43 does not allow opening of the door.

Figure 4 shows the door latch mechanism 10 in a locked condition with the child safety feature off. It should be noted that the cam 30 has been rotated 90 degrees in an anticlockwise direction when compared with Figure 1. This results in cam follower 22b being situated between lobes 32 and 33 thus ensuring that operation of outside release lever 40 does not release the latch mechanism. Furthermore, the rotation of the cam 30 has caused cam follower 21b to ride up cam lobe 31 causing inside lock link 21 to rotate anticlockwise about axis 21a. Thus abutment 21c of inside lock link 21 is contacted by abutment 45 of inside release lever 43 when it is operated. This causes anticlockwise rotation of the pawl lifter 20 about axis 16 resulting in unlatching of the door mechanism and allowing the door to be subsequently opened. Stop 21d limits the anticlockwise rotation of inside lock link 21. It should be noted that the operation of the inside release lever 43 also causes abutment 46 to contact lever 35 causing rotation of cam 30 to the position shown in Figure 5. This prevents a vehicle occupant inadvertently locking himself out of the vehicle since opening of the door from the inside automatically unlocks the door, allowing subsequent opening from the outside.

Figure 5 shows the door latch mechanism 10 in an unlocked position with the child safety feature off. It can be seen that the cam has been rotated (either by operating the inside release lever when the cam was in the position shown in Figure 4 or by independent rotation of the cam directly eg by a power actuator) such that abutment 22b now rests on lobe 33 allowing operation of the outside release lever 40 to unlatch the latch mechanism as described above. Furthermore abutment 21b remains in contact with lobe 31 thus ensuring that operation of the inside release lever also unlatches the door mechanism.

10

Figure 6 shows the door latch mechanism 10 in a released position. This is achieved by rotation of cam 30 in an anticlockwise direction which allows contact between corresponding lost motion abutments (not shown) on the pawl lifter 20 and cam 30. Such lost motion abutments allow the cam 30 to rotate the pawl lifter 20 to release the door latch mechanism independently of the operation of the outside release lever 40 or the inside release lever 43.

15

Note that only a single cam is required to effect the various modes of operation.

In further embodiments the inside and outside lock links can be mounted directly on the pawl.

20

Claims

1. A latch mechanism having a set of operating modes, each mode having alternate states, the set including at least two of a lock mode and a super lock mode, a child safety mode and a release mode, changing of the latch mechanism between alternate states of each of the at least two modes of the set being effected by a single power actuator, wherein a cam having a single plane profile is driven by the actuator to select the states.
5
2. A latch mechanism as defined in claim 1 in which the set includes the lock mode and the super lock mode and at least one of the child safety mode and release mode.
10
3. A latch mechanism as defined in claim 1 or 2 in which the set includes at least one of the lock mode and super lock mode and both of the child safety mode and the release mode.
15
4. A latch mechanism as defined in any preceding claim further comprising at least one of an inside and outside lock link movable by the cam between a first position representing a first of the alternate states and a second representing a second of the alternate states.
20
5. A latch mechanism as defined in claim 4 in which the at least one lock link is pivotally mounted for rotational movement between its first and second positions.
6. A latch mechanism as defined in claim 4 or claim 5 in which indexing of a cam effects movement of the at least one lock link between its first and second positions.
25
7. A latch mechanism as defined in claim 6 in which the cam is rotationally mounted for indexing.
30

8. A latch mechanism as defined in any one of claims 4 to 7 in which the cam includes at least two cam lobes which position the at least one lock link in one of the first and second positions, with the at least two cam lobes being separated by a cam valley which positions the at least one lock link in the other of the first and second positions.
9. A latch mechanism as defined in any one of claims 4 to 8 in which indexing of the cam effects both movement of both the inside and outside lock links.
10. A latch mechanism as defined in any one of claims 4 to 9 in which the cam has a plurality of lobes.
11. A latch mechanism as defined in any one of claims 4 to 10 further comprising release means in which the release means is capable of indexing the cam to move at least one of the lock links between the first and second positions.
12. A latch mechanism as defined in claim 11 in which the release means is capable of indexing the cam to move at least one of the lock links from its second position to its first position.

Amendments to the claims have been filed as follows

10

1. A latch mechanism having a set of operating modes, each mode having alternate states, the set including at least two of a lock mode, a super lock mode, a child safety mode and a release mode, changing of the latch mechanism between alternate states of
5 each of the at least two modes of the set being effected by a single power actuator, wherein a cam having a single plane profile is driven by the actuator to select the states.

2. A latch mechanism as defined in claim 1 in which the set includes the lock mode and the super lock mode and at least one of the child safety mode and release mode.

10

3. A latch mechanism as defined in claim 1 or 2 in which the set includes at least one of the lock mode and super lock mode and both of the child safety mode and the release mode.

15 4. A latch mechanism as defined in any preceding claim further comprising at least one of an inside and outside lock link movable by the cam between a first position representing a first of the alternate states and a second representing a second of the alternate states.

20 5. A latch mechanism as defined in claim 4 in which the at least one lock link is pivotally mounted for rotational movement between its first and second positions.

6. A latch mechanism as defined in claim 4 or claim 5 in which indexing of a cam effects movement of the at least one lock link between its first and second positions.

25

7. A latch mechanism as defined in claim 6 in which the cam is rotationally mounted for indexing.

8. A latch mechanism as defined in any one of claims 4 to 7 in which the cam includes at least two cam lobes which position the at least one lock link in one of the first and second positions, with the at least two cam lobes being separated by a cam valley which positions the at least one lock link in the other of the first and second positions.
9. A latch mechanism as defined in any one of claims 4 to 8 in which indexing of the cam effects both movement of both the inside and outside lock links.
10. A latch mechanism as defined in any one of claims 4 to 9 in which the cam has a plurality of lobes.
11. A latch mechanism as defined in any one of claims 4 to 10 further comprising release means in which the release means is capable of indexing the cam to move at least one of the lock links between the first and second positions.
12. A latch mechanism as defined in claim 11 in which the release means is capable of indexing the cam to move at least one of the lock links from its second position to its first position.



INVESTOR IN PEOPLE

Application No: GB 0202069.1
Claims searched: 1 to 12

Examiner: Matthew Parker
Date of search: 18 February 2002

Patents Act 1977 Search Report under Section 17

Databases searched:

UK Patent Office collections, including GB, EP, WO & US patent specifications, in:
UK Cl (Ed.T): E2A: AARN
Int Cl (Ed.7): E05B: 65/12, 65/32
Other: Online: EPODOC, JAPIO, WPI

Documents considered to be relevant:

Category	Identity of document and relevant passage	Relevant to claims
X	WO 98/05840 A1 (JUNG et al), see abstract and motor 22	1-3
X	US 5419597 (KIEHERT), see abstract and motor 26	1,2

X	Document indicating lack of novelty or inventive step	A	Document indicating technological background and/or state of the art.
Y	Document indicating lack of inventive step if combined with one or more other documents of same category.	P	Document published on or after the declared priority date but before the filing date of this invention.
&	Member of the same patent family	E	Patent document published on or after, but with priority date earlier than, the filing date of this application.