

(21) Application No **8414031**  
(22) Date of filing **1 Jun 1984**  
(30) Priority data  
(31) **8315345** (32) **3 Jun 1983** (33) **GB**

(51) INT CL<sup>3</sup>  
**B60J 7/18**  
(52) Domestic classification  
**B7B 287 28Y 354 AM**  
(56) Documents cited  
**None**  
(58) Field of search  
**B7B**

(71) Applicant  
**Britax Weathershields Limited (United Kingdom),  
180 Sherlock Street, Birmingham B33 0SJ**  
(72) Inventor  
**Sidney Edward Fisher**  
(74) Agent and/or Address for Service  
**A Hollinghurst,  
Britax Central Services, 40 Granby Avenue, Garretts  
Green, Birmingham B33 0SJ**

(54) **Opening roofs for vehicles**

(57) A sun blind for an opening roof for a vehicle comprises an opaque panel 22 dimensioned to cover at least a substantial part of the opening. The panel has latching formations 26 adjacent to one edge thereof for engagement with complementary formations 24 adjacent to a corresponding edge of the roof opening. A latch member 28 is resiliently mounted on the panel 22 adjacent to the opposite edge thereof so as to be biased into engagement with complementary formations 30 on the corresponding edge of the roof opening. Displacement of the panel 22 towards the formations 30 compresses the resilient mountings of the latch member 28 and disengages the latching formations 26 from their complementary formations 24.

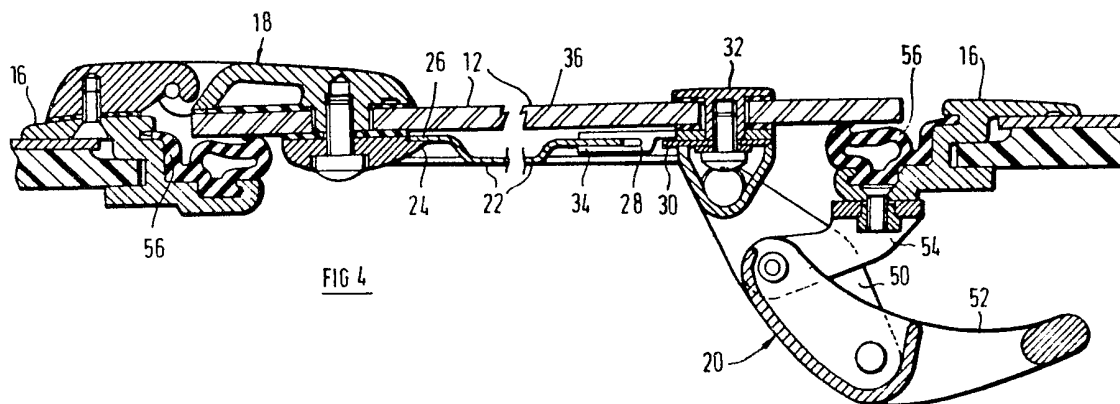

FIG 4

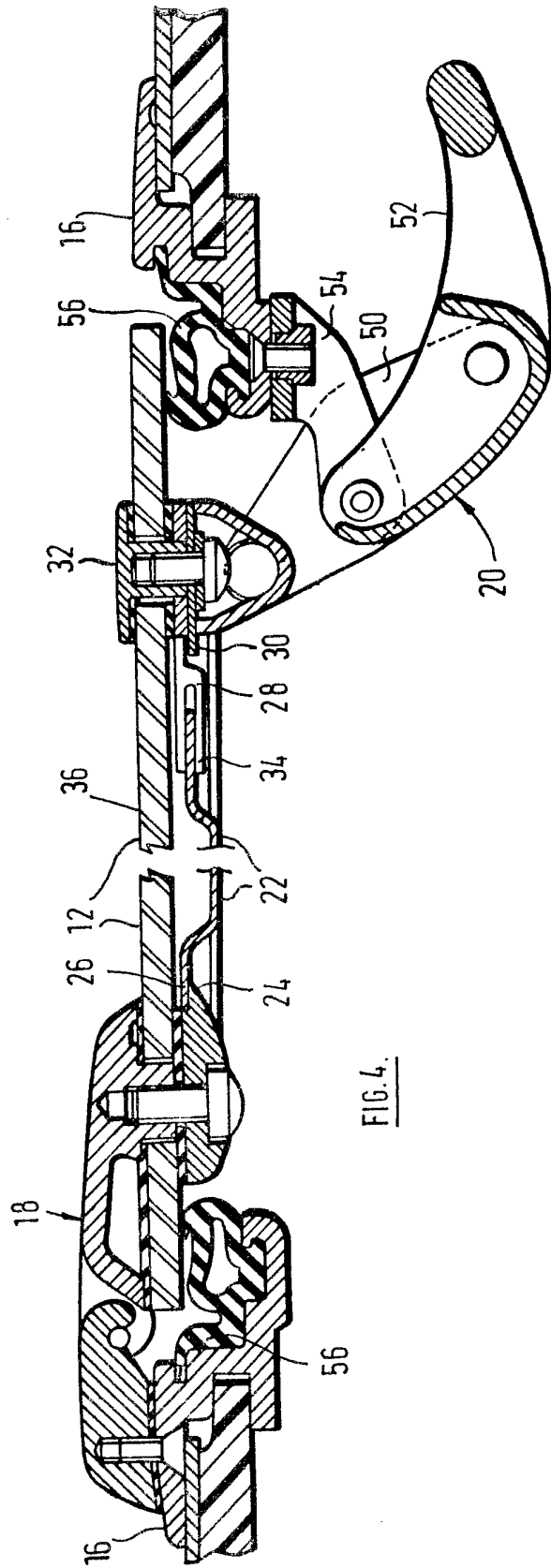
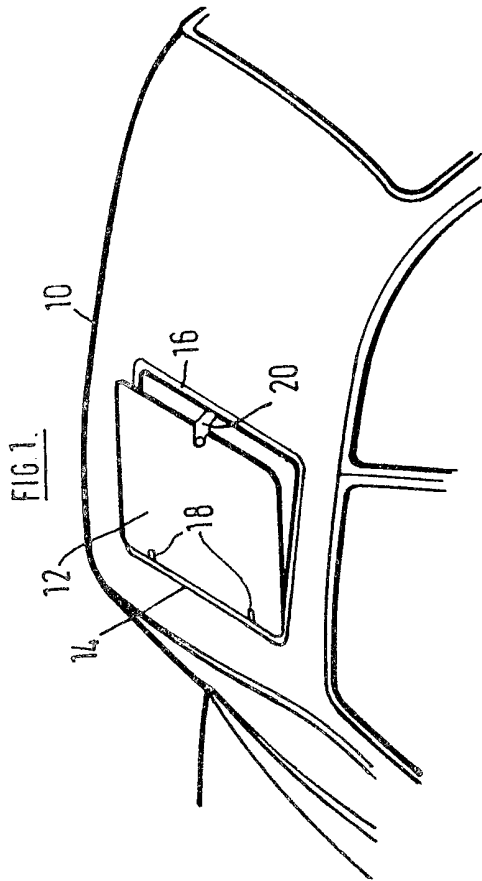
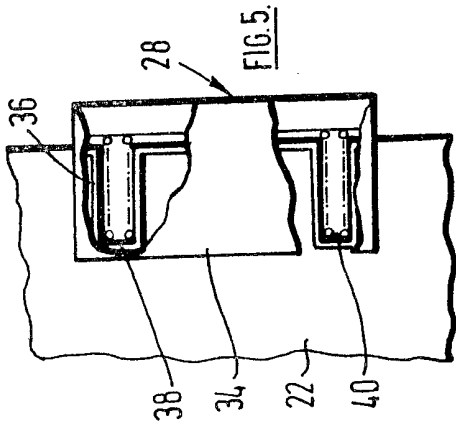
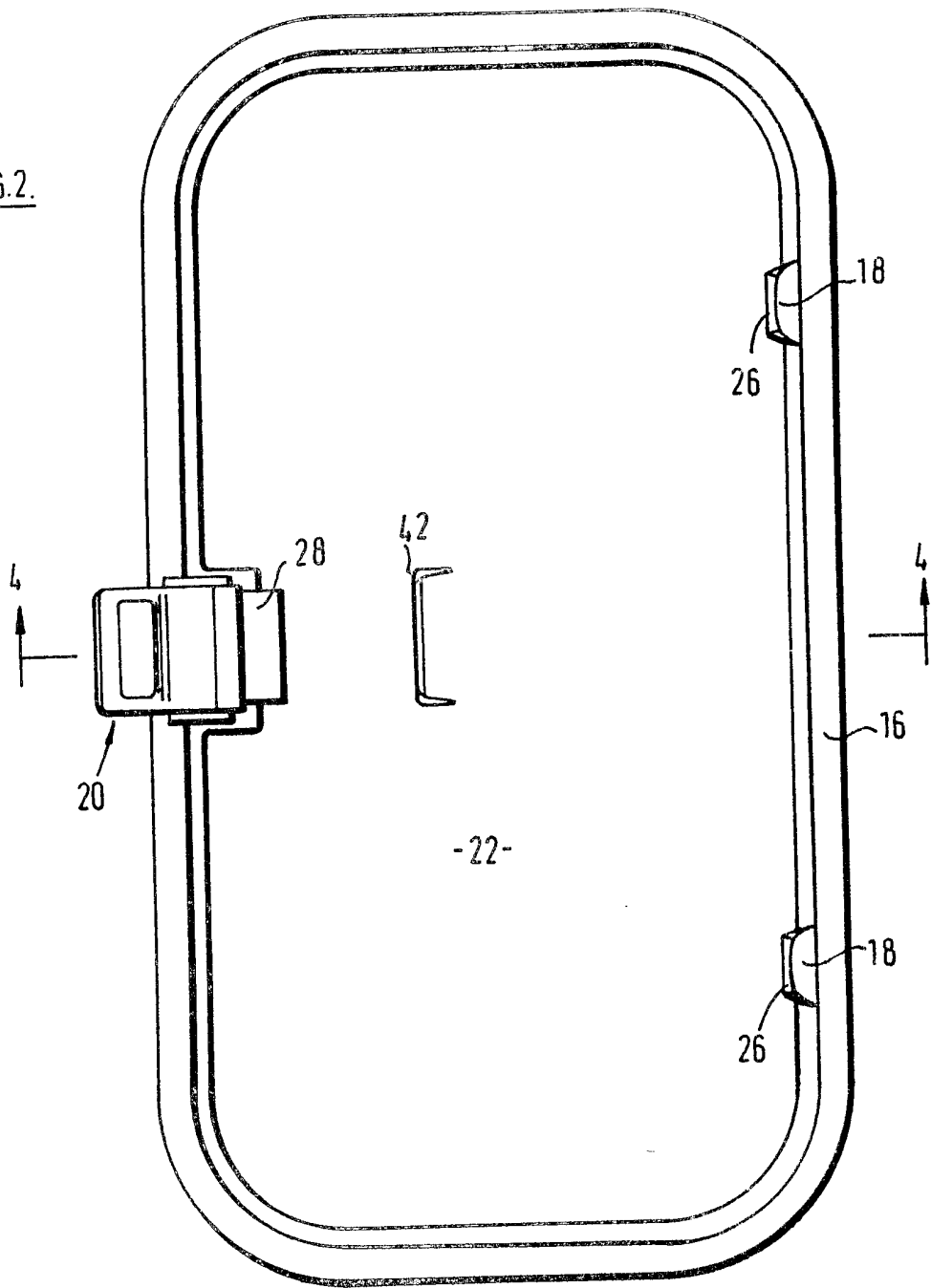

FIG. 4.

FIG. 2.



-22-

FIG. 3.

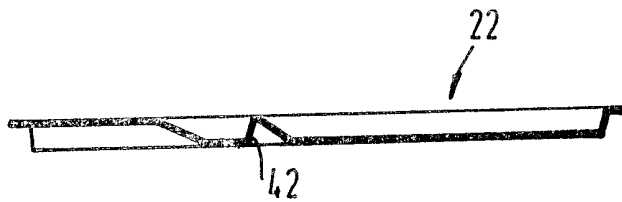

## SPECIFICATION

## Opening roofs for vehicles

5 This invention relates to opening roofs for vehicles of the kind in which an aperture in the roof is closed by a rigid transparent panel, conveniently of glass, which is hinged to the forward edge of the opening, and is particularly concerned with the provision of a sun blind for use with an opening roof of the foregoing type.

10 According to the invention, a sun blind for an opening roof for a vehicle comprises an opaque panel dimensioned to cover at least a substantial part of the opening and having first latching formations adjacent to a first edge thereof adapted to engage in complementary formations adjacent to a corresponding first edge of the roof opening, and second latching formations resiliently mounted on the panel adjacent to a second edge thereof opposite to said first edge so as to be biased into engagement with complementary formations on a second edge of the roof opening opposite to the first edge thereof, whereby displacement of the panel towards the second edge of the roof opening compresses the resilient mountings of the second latching formations and disengages the first latching formations from their complementary formations.

15 Preferably a handle is provided on the lower side of the panel to facilitate displacement thereof towards the second edge of the roof opening.

An embodiment of the invention will now be described, by way of example, with reference to the accompanying drawings in which:

20 *Figure 1* is a perspective view of the top of a motor car fitted with an opening roof of the type referred to above;

25 *Figure 2* is a plan view from below of the opening roof shown in Fig. 1, fitted with a sun blind in accordance with the invention;

30 *Figure 3* is a cross-sectional view of the sun blind shown in Fig. 2 taken on the longitudinal centre line thereof;

35 *Figure 4* is a fragmentary cross-sectional view taken on the line 4-4 in Fig. 2; and

40 *Figure 5* is a partially broken away scrap plan view from below showing the second latching formation.

45 Referring to Fig. 1, a motor car has an opening roof comprising a transparent panel 12, hinged along its leading edge 14 to a frame 16 bounding an aperture in the roof of the vehicle 10. A latch 20 at the rear of the panel 12 is arranged to hold the panel 12 either in the normal open position, as illustrated, or in the fully closed position (illustrated in Figs. 2 and 4).

50 Referring to Figs. 2, 3 and 4, a sun blind in the form of an opaque panel 22 is located below the transparent panel 12 and occupies

51 substantially the whole of the opening. Each of the hinges 18 has a respective shoulder 24 which, with the transparent panel 12, defines a groove for receiving a corresponding latching formation 26 formed on the front edge of the opaque panel 22. On its rear edge, adjacent to the handle 20, the panel 22 carries a sliding latch member 28 which is received in a slot formed between the panel 12 and a plate 30 carried by the part 32 of the latch 20 which is secured to the panel 12. The latch 28 has side limbs 34 and 36 which engage below and above the panel 22 respectively. As can be seen from Fig. 5, compression springs 38 and 40 are received in respective pockets formed in the edge of the panel 22 between the limbs 34 and 36 so as to bias the latch member 28 outwardly from the panel 22.

55 As can be seen from Figs. 2 and 3, a handle 42 is integrally formed in the central region of the panel 22. When the panel 22 is fitted into the frame 16 of the opening roof, the handle 42 can be used to displace it towards the latch 20, compressing the springs 38 and 40 and disengaging the projections 26 from the shoulders 26 on the hinges 18. The front edge of the panel 22 can then be lowered clear of the frame 16 whereupon the latch 28 can be disengaged from the plate 30 and the whole panel removed.

60 In order to replace the panel 22 in the frame 16, the latch 28 is first engaged above the plate 30 and the springs 38 and 40 are compressed, using the handle 42 as before, so as to permit the projections 26 to be inserted above their respective shoulders 24.

65 The hinges 18 and latch 20 are generally as described in Patent Specification No. EP-001043 and will not be described in detail. Briefly, the handle 20 incorporates an over-centre toggle comprising a link 50 pivoted at one end to the part 32 which is secured to the panel 12 and pivoted at the other end to a handle 52. The handle 52 forms a second link of the toggle mechanism and is pivoted to a member 54 secured to the frame. The frame 16 is provided with a conventional resilient seal 56 which serves to form a waterproof joint with the panel 12.

70 The panel 22 may be formed of a semi-opaque material instead of a fully opaque material if desired.

## CLAIMS

75 1. A sun blind for an opening roof for a vehicle comprising an opaque panel dimensioned to cover at least a substantial part of the opening and having first latching formations adjacent to a first edge thereof adapted to engage in complementary formations adjacent to a corresponding first edge of the roof opening, and second latching formations resiliently mounted on the panel adjacent to a second edge thereof opposite to said first

- edge so as to be biased into engagement with complimentary formations on a second edge of the roof opening opposite to the first edge thereof, whereby displacement of the panel
- 5 towards the second edge of the roof opening compresses the resilient mountings of the second latching formations and disengages the first latching formations from their complementary formations.
- 10 2. A sun blind according to claim 1, wherein the second latching formations comprise one edge of a latch member having two side limbs which engage above and below the panel.
- 15 3. A sun blind according to claim 2, wherein a pocket is formed in the edge of the panel between the side limbs of the latch member, the resilient mounting for the latch member comprising a spring accommodated
- 20 in the pocket.
4. A sun blind according to claim 1, 2 or 3, wherein a handle is formed integrally with the opaque panel so as to project from the lower side thereof.
- 25 5. A sun blind for an opening roof for a vehicle, substantially as hereinbefore described with reference to the accompanying drawings.