

(12) STANDARD PATENT
(19) AUSTRALIAN PATENT OFFICE

(11) Application No. **AU 2007207830 B2**

(54) Title
Eyewear frames with magnetic lens attachments

(51) International Patent Classification(s)
G02C 1/00 (2006.01)

(21) Application No: **2007207830** (22) Date of Filing: **2007.01.11**

(87) WIPO No: **WO07/084311**

(30) Priority Data

(31) Number	(32) Date	(33) Country
60/758,562	2006.01.13	US

(43) Publication Date: **2007.07.26**

(44) Accepted Journal Date: **2012.03.01**

(71) Applicant(s)
Switch Vision, LLC.

(72) Inventor(s)
Dichiara, Carmine S.

(74) Agent / Attorney
FB Rice, Level 23 44 Market Street, Sydney, NSW, 2000

(56) Related Art
US 3838914
US 2005/0007546
US 6592220
US 6478420

(19) World Intellectual Property Organization
International Bureau



(43) International Publication Date
26 July 2007 (26.07.2007)

PCT

(10) International Publication Number
WO 2007/084311 A3

- (51) International Patent Classification:
G02C 1/00 (2006.01)
- (21) International Application Number:
PCT/US2007/000681
- (22) International Filing Date: 11 January 2007 (11.01.2007)
- (25) Filing Language: English
- (26) Publication Language: English
- (30) Priority Data:
60/758,562 13 January 2006 (13.01.2006) US
- (71) Applicant (for all designated States except US): **LIBERTY SPORT, INC.** [US/US]; 107 Fairfield Road, Fairfield, NJ 07004 (US).
- (72) Inventor; and
- (75) Inventor/Applicant (for US only): **DICHIARA, Carmine, S.** [US/US]; 23 Gregory Lane, Warren, NJ 07059 (US).
- (74) Agents: **LANE, John, R.** et al.; Frommer, Lawrence & Haug Llp, 745 Fifth Avenue, New York, NY 10151 (US).
- (81) Designated States (unless otherwise indicated, for every kind of national protection available): AE, AG, AL, AM, AT, AU, AZ, BA, BB, BG, BR, BW, BY, BZ, CA, CH, CN,

CO, CR, CU, CZ, DE, DK, DM, DZ, EC, EE, EG, ES, FI, GB, GD, GE, GH, GM, GT, HN, HR, HU, ID, IL, IN, IS, JP, KE, KG, KM, KN, KP, KR, KZ, LA, LC, LK, LR, LS, LT, LU, LV, LY, MA, MD, MG, MK, MN, MW, MX, MY, MZ, NA, NG, NI, NO, NZ, OM, PG, PH, PL, PT, RO, RS, RU, SC, SD, SE, SG, SK, SL, SM, SV, SY, TJ, TM, TN, TR, TT, TZ, UA, UG, US, UZ, VC, VN, ZA, ZM, ZW.

(84) Designated States (unless otherwise indicated, for every kind of regional protection available): ARIPO (BW, GH, GM, KE, LS, MW, MZ, NA, SD, SL, SZ, TZ, UG, ZM, ZW), Eurasian (AM, AZ, BY, KG, KZ, MD, RU, TJ, TM), European (AT, BE, BG, CH, CY, CZ, DE, DK, EE, ES, FI, FR, GB, GR, HU, IE, IS, IT, LT, LU, LV, MC, NL, PL, PT, RO, SE, SI, SK, TR), OAPI (BF, BJ, CF, CG, CI, CM, GA, GN, GQ, GW, ML, MR, NE, SN, TD, TG).

Declarations under Rule 4.17:

- as to applicant's entitlement to apply for and be granted a patent (Rule 4.17(ii))
- as to the applicant's entitlement to claim the priority of the earlier application (Rule 4.17(iii))

Published:

- with international search report

[Continued on next page]

(54) Title: EYEWEAR FRAMES WITH MAGNETIC LENS ATTACHMENTS

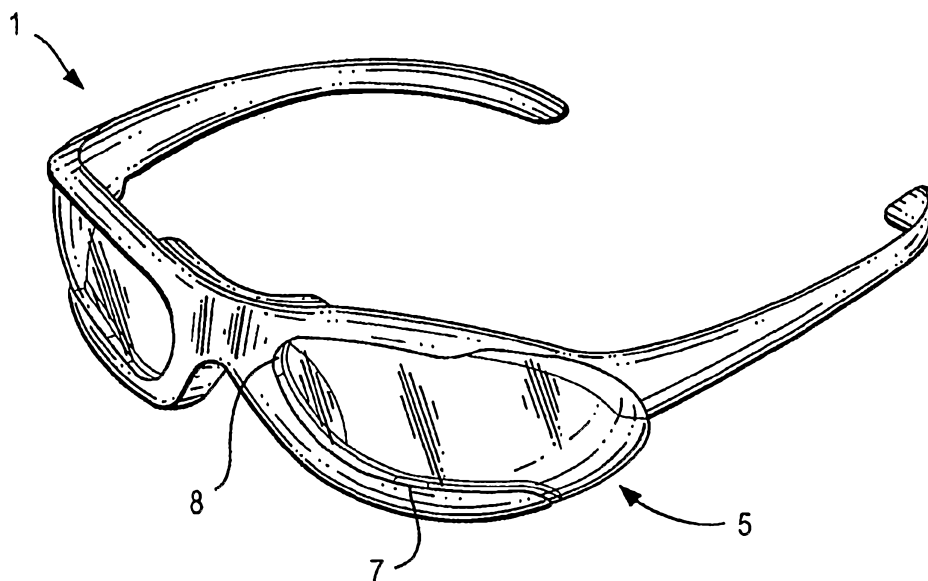

(57) Abstract: The present invention illustrates various methods of attaching a pair of eyeglass lenses or a lens shield to an eyeglass frame using magnets or magnetically attractive material. The magnetic attachment methods are beneficial because they allow the user to have interchangeable lenses or shields for indoor and outdoor use, enhancing their visual acuity during work or play. The lenses may be tinted, prescription, protective eyewear, or plano. The magnetic lenses are convenient and user friendly, allowing intuitive, tool-less interchangeability with no need to twist or stress the frame. These methods of attachment require no specific instructions or tools when the user replaces lenses.



WO 2007/084311 A3



— *before the expiration of the time limit for amending the claims and to be republished in the event of receipt of amendments*

For two-letter codes and other abbreviations, refer to the "Guidance Notes on Codes and Abbreviations" appearing at the beginning of each regular issue of the PCT Gazette.

(88) Date of publication of the international search report:

22 November 2007

EYEWEAR FRAMES WITH MAGNETIC LENS ATTACHMENTS

This application is based upon provisional patent application serial number 60/758,562,
5 which was filed on January 13, 2006.

Field of the Invention

[0001] The present invention relates to eyewear frames with magnetic lens attachments. More particularly, the present invention relates to eyeglass frames with interchangeable
10 prescription or plano lenses and/or plano shields that can be interchanged by the user in a simple, and convenient manner and that are easily releasably attached to the frame.

Background of the Invention

[0002] A typical pair of eyeglasses includes a pair of lenses or a single shield mounted to
15 a frame that may include rims around the lenses; a brow bar; a bridge piece connecting the inner ends of the rims; and two temple pieces attached to the outer ends of the rims for resting the glasses on the user. Lenses are typically mounted to the eyeglass frame by a screw or other fastening device that tightens the rim around the lens. In the conventional configuration, the screw must be removed before the lens may be removed. The screw is
20 often small and identifying the size and type of screw can require the user to strain his or her eyes. Removing the screw requires that the user have a screw driver or other tool that fits the particular screw in that pair of eyewear. Users will often not have the proper screwdriver. If the screw is broken or stripped, the user must then find a suitable replacement screw. This is inconvenient for the user as different eyeglasses use different kinds of screws which may
25 have different head types and sizes. These different screws will often not work in different pairs of eyeglasses or with different screwdrivers. Additionally, if the screw breaks while in the glasses, the user may have difficulty removing the broken screw. Users may also desire to change lenses while wearing the glasses to accommodate different lighting conditions. Mounting lenses to the frame using screws can make this process highly inconvenient for the
30 user.

[0003] Recently, prescription lenses have been developed with notches to make them interchangeable in brow bar designs if desired. This requires a forcing of the brow bar to go

over the notches in the lenses. This technique can be quite cumbersome to work with in both the insertion and removal of the lenses.

[0004] Examples of various prior eyewear are disclosed in the following patents and publications, the disclosures of which are hereby incorporated herein by reference: U.S. patents 3,565,517 to Gitlin et al, 3,838,914 to Fernandez, 5,321,442 to Albanese, 5 6,592,220 to Cheong, and 6,866,386 to Chen; Japanese patent applications 59072417, 60140316, and 2004021086; and PCT patent application WO 96/37800.

[0005] Accordingly, there is a need for providing an easily replaceable, convenient mechanism for coupling interchangeable eyeglass lenses to frames.

10 [0006] Any discussion of documents, acts, materials, devices, articles or the like which has been included in the present specification is not to be taken as an admission that any or all of these matters form part of the prior art base or were common general knowledge in the field relevant to the present invention as it existed before the priority date of each claim of this application.

15 [0007] Throughout this specification the word "comprise", or variations such as "comprises" or "comprising", will be understood to imply the inclusion of a stated element, integer or step, or group of elements, integers or steps, but not the exclusion of any other element, integer or step, or group of elements, integers or steps.

20 Summary of the Invention

[0008] According to a first aspect of the invention, there is provided a lens apparatus for removably mounting a primary lens to an eyeglass frame comprising a lens and at least one lens magnetic member, the lens comprising:

- 25 a lens front surface having a front circumferential edge;
- a lens rear surface having a rear circumferential edge spaced a distance from said front circumferential edge;
- a lens thickness spaced between the front lens surface and the rear lens surface;
- a lens edge surface spaced between the front circumferential edge and the rear circumferential edge; and
- 30 a cavity extending through the lens thickness, the cavity having a proximal cavity portion proximal to the circumferential edge and having a first cavity dimension; and

the cavity having a distal cavity portion distal from the circumferential edge and having a second cavity dimension, wherein the second cavity dimension is larger than the first cavity dimension;

wherein the at least one lens magnetic member comprises:

5 a magnetic member front surface;

a magnetic member rear surface;

a magnetic member edge surface;

wherein a first portion is sized to fit within the first cavity portion; and

a second portion is sized to fit within the second cavity portion,

10 wherein the magnetic member front surface is substantially flush with the lens front surface, the magnetic member rear surface is substantially flush with the lens rear surface and the magnetic member edge surface is substantially flush with the lens edge surface.

[0009] According to a second aspect of the invention, there is provided an eyeglass
15 assembly comprising a primary eyeglass frame adapted for removable mounting of a primary lens thereto, the assembly further comprising:

at least one primary lens having a front surface, a rear surface, a circumferential edge thickness, an edge surface, and at least one lens cavity extending through the circumferential edge thickness, the at least one lens cavity having a proximal cavity
20 portion proximal to the circumferential edge and having a first lens cavity dimension, and a distal cavity portion distal to the circumferential edge and having a second lens cavity dimension larger than the first lens cavity dimension;

a primary eyeglass frame comprising at least one partial lens rim portion comprising:

25 a front frame portion having a front frame surface,

a rear frame portion separated a distance from and opposing the front frame surface,

a connecting frame portion connecting the front frame portion and the rear frame portion, the connecting portion comprising:

30 a mounting surface; and

at least one frame cavity extending through the connecting frame portion, the at

least one frame cavity having a first frame cavity portion proximal to the mounting surface having a first frame cavity dimension, and a second frame cavity portion distal from the mounting surface having a second frame cavity dimension larger than the first frame cavity dimension;

5 at least one lens magnetic member configured to closely engage the at least one lens cavity such that a lens magnet front surface is substantially flush with the lens front surface, a lens magnet rear surface is substantially flush with the lens rear surface and a lens magnet edge surface is substantially flush with the lens edge surface; and

at least one frame magnetic member configured to closely engage the at least
10 one frame cavity such that at least a portion of a frame magnetic member edge surface is substantially flush with the mounting surface.

[0010] According to a third aspect of the invention, there is provided a lens apparatus for removably mounting a primary lens to an eyeglass frame comprising a lens and at least one lens magnetic member, the lens comprising:

15 a lens front surface having a front circumferential edge;
a lens rear surface having a rear circumferential edge spaced a distance from said front circumferential edge;

a lens thickness spaced between the front lens surface and the rear lens surface;
a lens edge surface spaced between the front circumferential edge and the rear
20 circumferential edge; and

a cavity extending at least partially through the lens thickness, the cavity having a proximal cavity portion proximal to the circumferential edge and having a first cavity dimension; and the cavity having a distal cavity portion distal from the circumferential edge and having a second cavity dimension, wherein the second cavity dimension is
25 larger than the first cavity dimension;

wherein the at least one lens magnetic member comprises:

a magnetic member front surface;
a magnetic member rear surface;
a magnetic member edge surface; wherein

30 the lens magnet having a first portion with a first magnet dimension sized to fit within the first cavity portion and a second lens magnet portion sized to fit within the second cavity portion such that the lens magnetic member front surface is substantially

flush with the lens front surface, the magnetic member rear surface is substantially flush with the lens rear surface and the magnetic member edge surface is substantially flush with the lens edge surface.

[0011] According to a fourth aspect of the invention, there is provided an eyeglass

5 assembly comprising a primary eyeglass frame adapted for removable mounting of a primary lens thereto, the assembly further comprising:

at least one primary lens having a front surface,

a rear surface, a circumferential edge thickness, an edge surface, and a lens cavity extending at least partially through the circumferential edge thickness,

10 the lens cavity having a proximal cavity portion proximal to the circumferential edge and having a first lens cavity dimension, and a distal cavity portion distal to the circumferential edge and having a second lens cavity dimension larger than the first lens cavity dimension;

a primary eyeglass frame comprising at least one partial lens rim portion;

15 wherein the at least one lens magnetic member comprises:

a magnetic member front surface;

a magnetic member rear surface;

a magnetic member edge surface; wherein

20 the lens magnet having a first portion with a first magnet dimension sized to closely fit within the first lens cavity portion and a second lens magnet portion sized to closely fit within the second cavity portion such that the lens magnetic member front surface is substantially flush with the lens front surface, the magnetic member rear surface is substantially flush with the lens rear surface and the magnetic member edge surface is substantially flush with the lens edge surface.

25 [0012] [blank]

[0013] In embodiments of the invention, there are provided a single shield-type lens or a pair of interchangeable lenses that may be placed in position in eyeglass frames using magnetic members to lock the respective lenses in place. The lenses may be embedded with or otherwise support magnets or a magnetic material. The magnets or magnetic
30 material in the lenses are attracted to corresponding magnets or magnetic material in a pair of eyeglass frames.

[0014] It is to be understood that in all embodiments of the present invention, the lenses and frames may both be mounted with permanent magnets. Alternatively, either the lenses or the frame may have permanent magnets secured to one or the other, while the other of the lenses and the frame may have secured to it, or may be made of,
5 magnetically attractive material, such as ferrous metal.

[0015] In embodiments of the invention, the magnets or magnetic material can be positioned at various points of the frame and lens, such as in the annular areas or inner circumference of the frame and in the brow bar or nosepiece. The lenses are easily removable, providing a rapid and simple interchange of lenses. The magnets or
10 magnetic material in the lenses can be mounted in a number of ways, including a 3-piece mounted frame, generally suitable for rimless frames. Another option is to provide a lens that fits into frames having a closed annular shelf with magnets on opposite sides, where the shelf prevents the lens from falling backwards out of the frame.

[0016] Objects, advantages, and salient features of the present invention will become
15 apparent from the following detailed description, which, taken in conjunction with the annexed drawings, discloses preferred embodiments of the invention.

Brief Description of the Drawings

[0017] FIG. 1a is a front view of a pair of eyewear frames and detached lens, both
20 comprising magnets according to a first embodiment of the invention;

[0018] FIG. 1b is a front view of a lens with magnets or magnetic material embedded therein;

[0019] FIG. 1c is a side view of a lens having no magnets or magnetic material;

[0020] FIG. 1d is a front view of a lens with magnets or magnetic material secured to
25 the lens so that said magnets or magnetic material protrude beyond the edge of the lens;

[0021] FIG. 2 is a front view of a pair of eyewear frames, as seen in FIG. 1, with the lenses mounted to the frame;

[0022] FIGS. 3 a and 3b are cross-sectional views of the eyewear frames, as seen in FIGS. 1 and 2, at the point of magnetic attachment;

30 [0023] FIG. 4 is a front view of a 'blade'-style frame with magnetic lenses;

- [0024]** FIGS. 5a-5c are front views of an alternative embodiment having magnets protruding from the top and nasal area of the lenses, which are received into pockets containing magnetic material on the horizontal arm and nose piece of the frame;
- [0025]** FIG. 5d is a cross-sectional view of a T-shaped magnetic attachment extending
5 from the lens and received into a corresponding pocket of the frame, according to another embodiment of the present invention;
- [0026]** FIG. 6a is a perspective view of a pair of eyewear frames according to another embodiment of the invention;
- [0027]** FIG. 6b is a perspective view of a lens according to an embodiment of the
10 invention;
- [0028]** FIG. 6c is a cross-section of the frame and lens of the embodiment shown in FIG. 6a;
- [0029]** FIG. 7 is a front view of a partial eyewear frame having magnets glued into the rims according to all embodiments illustrated;
- [0030]** FIGS. 8a-8d are sectional views of magnets embedded in channels in the lens rims
15 of frames in different embodiments of the present invention;
- [0031]** FIGS. 9a-9d are side views of magnets or magnetic material secured to various lenses;
- [0032]** FIGS. 10a-10b are front views of an embodiment of the present invention in a
20 blade-style frame;
- [0033]** FIG. 11a is a front view of a semi-rimmed frame embodiment of the present invention;
- [0034]** FIG. 11b is a side view of portions of a partial rim, which were shown in FIG. 11a, according to another embodiment of the present invention;
- [0035]** FIG. 11c is a front view of a lens, which was shown in FIG. 11a, according to
25 another embodiment of the present invention;
- [0036]** FIG. 11d is a side view of a lens, as shown in FIG. 11c, according to an embodiment of the present invention;
- [0037]** FIG. 11e is a front view of a lens and partial rim, which were shown in FIG. 11a,
30 according to another embodiment of the present invention;
- [0038]** FIGS. 12a-12c' show a three-piece-mount embodiment of the present invention;

[0039] FIG. 13 is a front view of a magnetic rimlock closure embodiment of the present invention;

[0040] FIGS. 14a-14c are front and side views of an embodiment of the present invention with a slide pin;

5 **[0041]** FIGS. 15a-15h are front and side/sectional views of the various shapes of magnets possible with the various methods of attachment;

[0042] FIG. 16a is a perspective view of an embodiment of the present invention having a goggle-style frame and two shield-style lenses;

10 **[0043]** FIG. 16b is a cross-sectional view of an embodiment of the present invention having a goggle-style frame and two shield-style lenses;

[0044] FIG. 16c is a front view of a pair of lenses that could be combined with the embodiment shown in FIG. 16a;

[0045] FIG. 17a is a front view of a lens with a wire surrounding its edge;

15 **[0046]** FIG. 17b is a front view of a lens with a wire surrounding its edge and a magnet or magnetic material embedded in the lens;

[0047] FIG. 17c is a perspective view of a wire partially embedded in a groove in the edge of a lens; and

[0048] FIG. 17d is a top view of the lens in FIG. 17b.

20 **Detailed Description of the Invention**

[0049] As used herein, the term "lens" will be understood to include eyeglass lenses of a variety of shapes and sizes as well as one or more shield style lenses. As used herein, the term "frame" will be understood to include blade-style frames, goggle-style frames, conventional frames, and any other style of eyewear frame. As used herein, the term "plano lens" shall refer to lenses and shields that are not made to fill a wearer's prescription. The term "prescription lens" shall refer to lenses and shields that are made to fill a wearer's prescription as used in this description. "Plano lens" and "prescription lens" are used interchangeably throughout this specification. The terms "magnets," "magnetic member," "magnetized material," and "magnetic material," as used in this description, refer to magnets or material that has magnetic properties or is capable of attracting a magnet. As such, "magnets," "magnetic member," "magnetized material," and "magnetic material," are interchangeable in this description. A "magnetic member" as used herein is a component of

30

an eyeglass assembly that is either a magnet or is made from magnetically attractive material. An "eyeglass assembly," as used in this description, refers to an assembled pair of eyeglasses including a frame and at least one lens.

[0050] FIG. 1 shows an embodiment of the present invention. A pair of eyeglass frames
5 1 includes at least one magnet or element of magnetically attractive material 7 embedded in the frame 1. In FIG. 1a, each side of the frame 1 includes a portion of a rim 2 and 3 for supporting a lens 5. Each rim portion 2 and 3 includes a recess 6 into which a lens 5 may be received. The recess 6 may extend toward the nosepiece 4. Magnets or magnetically attractive material 7 are embedded into the recesses 6 in the rim portions 2
10 and 3 of the frame 1. Preferably, at least one magnet or element of magnetically attractive material 7 is located on each side in the recess 6 of the frame 1 that may receive a lens 5. Magnets or magnetic material having opposing and attractive forces 8 are attached to the corresponding ends of the eyeglass lenses 5 such that, when the lenses 5 are held close to the frames 1, the attractive forces of the positively and negatively
15 charged magnets pull the magnets 8 of the lenses 5 towards the magnets 7 of the frames 1. The magnets 7 are preferably embedded in the recess 6 of the frames 1 and the corresponding edge(s) 9 of each of the lenses 5. This formation of the magnets provides a fully seated lens that is held in place through magnetic forces, as seen in FIG. 2.

[0051] FIG. 1b shows a lens with magnets or magnetic material 8 embedded therein. A
20 lens 5 has a front surface 10, a rear surface 11 and an edge 9. FIG. 1c shows a lens 5 laying on its rear surface 11, with its edge 9 facing the reader, and its front surface 10 pointing toward the top of the page. The lens 5 in FIG. 1c is similar to the lens in FIG. 1b with no magnets or magnetic material embedded in the lens 5. In the lens shown in FIG. 1b, the magnets or magnetic material 8 secured to the lens 5 lies flush with the edge
25 9 of the lens 5. The magnets or magnetic material 8 may be flush with the front 10 or rear 11 surfaces of the lens 5. It is not necessary that the magnet or magnetic material 8 lie flush with or break the plane of the edge 9 or the front 10 or rear 11 surfaces. The lens may cover the magnet or magnetic material as long as the magnet or magnetic material, when assembled, is sufficiently close to the corresponding magnets or
30 magnetic material in the frame that the magnets or magnetic material in the frame and the lens attract one another.

[0052] FIG. 1d shows another lens according to an embodiment of the present invention. Magnets or magnetic material 8 protrude beyond the edge 9 of the lens 5.

[0053] FIG. 2 shows a front view of an assembled eyeglass frame assembly according to an embodiment of the present invention. The frame **1** contains magnets or magnetic material **7** embedded therein. The lens **5** also contains magnets or magnetic material **8** embedded therein. The attractive forces between the magnets or magnetic material in the frame **7** and the magnets or magnetic material in the lenses **8** secure the lenses **5** to the frame **1**.

[0054] The cross-sectional view of FIG. 3a depicts the point of contact between the lens **5** and the frames **1**. The frames **1** include a first **2** and a second **3** rim section. The first **2** and second **3** rim sections have a recess **6** for receiving the lens **5**. The recesses **6** are shaped to fit the contour of the lens edges. Typically the recesses **6** are U-shaped, for receiving an end of a lens **5**. The nose piece **4** may also have a recess and contain magnetic material. Magnets or magnetic material **8** are secured to the outside of the lens **5**, and are positioned near the magnets **7** in the frame **5**. The figure shows the front surface of the eyeglasses with the front surface of the lens **10** facing toward the reader. The location of the edge **9** of the lens **5** can also be seen in the cross-section.

[0055] FIG. 3b illustrates a cross-section of the eyewear illustrated in FIG. 3a, but with a first and a second magnet **8** embedded in the lens **5**. The magnetic lens **5** is snugly fitted to the frame **1** so as to not accidentally eject during normal use of the frame **1**.

[0056] In another embodiment of the present invention, the magnets or magnetically attractive material may be embedded in the lenses so as to be flush with the surface of the lenses. The lenses would be received into a recess similar to that shown in FIGS. 1-3, but without a lower rim section.

[0057] FIG. 4 shows another embodiment of the present invention. It is possible to attach lenses **5** containing magnets or magnetic material to 'blade'-style frames **12**. A 'blade'-style frame **12** is a winged frame conventionally designed so that there are no rims surrounding the lower arcuate surfaces of the lenses **5**. In other words, a 'blade'-style frame looks like a pair of lenses bordered by wings. Only the upper and nasal sections of the lenses **5** are engaged by the frame **12**. The points of contact between the frame **12** and the lenses **5** comprise a first section of a recess located in the horizontal bridge portion **47** of the frame **12** and a second section of a recess located in the side wall adjacent to a nosepiece **4**.

[0058] FIG. 5a shows an embodiment of the present invention. The 'blade'-style frame **12**, as seen in FIG. 4, can receive lenses **5** in a recess **6** of the upper rim portion **2** of the frame **12** and in a recess **6** in the side wall adjacent the nosepiece **4**. The lens **5** includes tabs

13 protruding from the edge of the lens 5. Magnets or magnetic material may comprise or be attached to the tabs 13.

[0059] FIG. 5b shows the same embodiment of the present invention as FIG. 5a, with the lens in place in the frame. The frame 12 has magnets 7 positioned in the recess of the upper rim portion 2 of the frame 12 and the nosepiece 4. A lens 5 is positioned in the frame 12, preparing for the magnetic forces of the magnets or magnetic material embedded in the frame 7 and the magnets or magnetic material embedded in the lens 8 to attract. The lens 5 has been inserted upwards into the recess in the upper rim portion 2 of the frame 12 where the tabs are received. Once the tab 13 is pulled into place by the nasal magnets 7, a second magnet embedded in a recess 6 in the upper rim portion 2 of the frame 12, pulls the tab 13 up into place creating a slight mechanical stop, resisting the lens 5 from sliding out of the groove 6.

[0060] As seen in FIG. 5c, the lens 5 is positioned into a recess 6 of the upper rim portion 2 of frame 12 and slid towards the nosepiece 4. Once in this position, the attractive forces of the opposing magnets, positioned in the lens 5 and frame 12, secure the lens 5 to the frame 12. Additionally, the magnet in the lens 5 locks into the recess 6 and resists the lens 5 from dislodging out of the 'blade'-style frame 12.

[0061] FIG. 5d shows another embodiment of the present invention. The lens 5 can comprise one magnet located at the portion of the lens 5 that attaches to the frame near the nasal area 4 and one mechanical "T" attachment 14 at the top. The frame 12 has magnets 7 positioned in the upper rim portion 2 of the frame 12 and the nosepiece 4.

[0062] FIGS. 6a-6c show another embodiment of the present invention. The frame 1 may include a full rim 21 encompassing a lens 5. In this embodiment, the lens 5 must be inserted from either the front 15 or the back, as opposed to being slid into the frame 1 from the side as with the embodiment shown in FIGS. 1-3. In this embodiment of the present invention, the frame 1 does not have a channel-recess, but rather has a stepped interior surface 22 that provides a mechanical stop for the lens 5 when inserted, as shown in FIG. 6c. The step may be a raised back wall so that the lens may only be removed through the front of the frame. Alternatively, the step 23 may be a front wall so that the lens 5 may only be removed through the back of the frame 1. In such an embodiment, the lens 5, with embedded magnets 8 near the edge 9, is inserted into a frame 1 with a raised front or back wall and positioned so that the magnets 8 of the lens 5 align with the magnets 7 in the frame 1. The lenses 5 are inserted

from the front or back accordingly, and are held into place by the magnetic force of the magnets on both the frame 1 and lenses 5.

[0063] FIG. 7 shows another embodiment of the present invention. Similar to the previously described embodiments, the magnets 7 can be secured to the frame 1 of the eyeglasses. Magnets or magnetic material 8 are also secured to the lens 5. The magnets or magnetic material 7 secured to the frame 1 are embedded in a recess, so that they lie flush with the surface of the frame 1. This allows the magnets or magnetic material 7 secured to the frame 1 to attract the magnets or magnetic material secured to the lens 5, while allowing the lens 5 to fit flush to the frame 1.

10 **[0064]** Alternatively, the recess in the frame does not need to span the length of the horizontal arm. Magnets protruding from the edge of the lens, such as the magnets visible in FIG. 1d, could be received in one or more recesses in the horizontal arm of a frame. In such an embodiment, magnets or magnetic material, corresponding to the magnets or magnetic material protruding from the edge of the lens, could be secured inside of recesses in the horizontal arm of the frame that are contoured to fit the protrusions on the lens. The protrusions of the lens would then fit inside of these recesses in the horizontal arm of the frame.

[0065] FIGS. 8a-8f show arrangements of magnets in the recesses of the frame. The recess can be of any shape. A recess having a square shape 26 and a recess having a triangular shape 16 are shown. In FIG. 8a, rectangular magnets 7 are positioned in a square-shaped recess 26 in a frame 1 so that a magnet is secured to each side of the recess. In FIG. 8b, a rectangular magnet 7 is positioned at the top of a square-shaped recess 26. Rectangular magnets need not be used. FIG. 8c shows a triangular-shaped magnet or magnets 18 secured to a frame having a triangular-shaped recess 16. FIG. 8d shows a triangular-shaped magnet 18 and recess 16 where the triangular shaped magnet 18 is not secured to all surfaces of the triangular-shaped recess 16.

[0066] Those skilled in the art will appreciate that there are many ways to configure the frame recesses in the rims to accept various types of lenses. There are even more possible ways to attach magnets to these different rim styles. The embodiments described are not intended to limit the combinations of magnetic placements and recesses in the rims. For example, those skilled in the art will appreciate that the horizontal arm of the frame could

contain a protruding magnet or a protrusion with a magnet or magnetic material secured thereto and the lens may contain a recess with a magnet or magnetic material.

[0067] As illustrated in FIGS. 9a-9d, magnets can be secured to prescription or plano lenses. In FIG. 9a, the lens 5 and the magnet 8 are of equal thickness, however the magnets or magnetically attractive material secured to the lens may be thinner or thicker than the lens. Additionally, the magnets or magnetically attractive material may be a thin plate that is formed into a shallow indentation in the edge of the lenses as shown in FIG. 9b.

[0068] It is also possible to press-fit the magnets 8 to lenses 5 having a notched surface, such as the lens 5 in FIG. 9c. The notched surface of the lens 5 is covered with a magnet that can be pressed over the lens 5 to create a corresponding surface for attaching the lens 5 to a frame. If desired, a magnet having a similar shape can be attached to a frame having a similar shape as this lens.

[0069] Magnets can be positioned on any side of the frame or recess and can be of any suitable shape. Magnets 8 can be attached to lenses having arcuate surfaces, such as the lens 5 in FIG. 9a. Magnets can also be attached to lenses having notches 19 that project away from the arcuate surface, such as the lens 5 in FIG. 9b. In either respect, the magnets are attached to the substantially arcuate portions of the lenses, not the notched portions. There is preferably a first magnet attached to the upper surface of the frame and a second magnet attached to the interim surface, close to the nosepiece. More than one magnet can be attached to either the lens or the frame.

[0070] Figure 10a shows a front view of another embodiment of the present invention. A lens 5 is secured to a frame 1. Magnets or magnetic material secured to the lens 8 attracts magnets or magnetic material secured to the frame 7. The magnets or magnetic material secured to the frame 7 are recessed in a channel in the frame 1 so that the magnets or magnetic material lie flush with the surface of the frame 1 and the top of the lens 5.

[0071] Figure 10b shows a front view of another embodiment of the present invention. A lens 5 is secured to a frame 1. Magnets or magnetic material secured to the lens 8 attracts magnets or magnetic material secured to the frame 7. The magnets or magnetic material secured to the frame 7 are recessed in a channel in the frame 1 so that the magnets lie flush with the surface of the frame 1 and the top of the lens 5. A notch 46 cut in the lens 5 is received in a similarly shaped recess in the frame 1 and assists in securing the lens 5 to the frame 1.

[0072] Another type of eyeglass frame that benefits from attaching magnetic lenses 5 to a frame having magnetic surfaces is the semi-rimmed frame 27, as illustrated in FIGS. 11a-11e. The frames 27 are typically metal rims 28 with substantially arcuate surfaces corresponding to the lower halves of the lenses 5, as seen in FIG. 11a. Only the lower portions of the lenses 5 and parts of the sides of the lenses 5 are covered by the frame 27. The remainder of the lens 5, the upper substantially arcuate surface, is rimless. Those skilled in the art will understand that this embodiment is not only limited to the lower portion of the lens being covered by the frame, but may include other partial sections of the lens, such as the top half of the lens covered by frame.

[0073] To secure lenses 5 in semi-rim frames 27, magnets 7 are embedded in the side surfaces 29 of the rims 28, towards the corners of the lenses 5, as shown in FIG. 11b and 11c. Persons of skill in the art will appreciate that the lens 5 could similarly be attached to the semi-rimmed frame by embedding magnets in the portion of the rim 28 encompassing the bottom surfaces of the lenses 5 and securing corresponding magnets 8 in the bottom portion of the lenses 5. Magnets, or magnetic material, 8 are attached to the edges 9 of the lenses 5, as shown in FIG. 11c, to match the corresponding bevel of the frame, as shown in FIG. 11b (square groove, substantially v-shaped groove, or round wire). This allows for a close fit between the magnetic lens 5 and the magnets or magnetic material 7 of the frames 27. The metal or molded wire of the eyeglass frames 27 is typically constructed from a square groove, a substantially v-shaped groove, or a round wire, also illustrated in FIG. 11b. FIG. 11e shows a front view of the lens and the semi-rimmed frame of FIG. 11a disassembled.

[0074] In yet another embodiment of the present invention, another type of magnetic attachment, illustrated in FIGS. 12a-12c', is associated with the three-piece mount, also referred to as a rimless mount. The three-piece mount involves a frame constructed without rims or eye wires. The three-piece mount has three pieces: the bridge bar 32, the temple or endpieces 31, and the lenses 5. Rimless mounts typically include two lenses 5 connected with a bridge bar 32 that attaches to the inner edge of the lenses 5, and temple or endpieces 31 that are attached to the outer edge of the lenses 5. The magnets in a three-piece mount link the three pieces to each other. The bridge bar 32 connects to the inner corners and/or edges of the lenses 5, and the temple or endpieces 31 connect to the outer corners or edges of the lenses 5.

[0075] The magnets 8 secured to the lenses 5 in the three-piece mount embodiment shown in FIGS. 12a-12b are attached to areas of each lens 5 defined by first and second indentations, collectively 30, on the front and rear surfaces at the inner and outer corners of the lenses 5. The magnets 8 are located directly between the first and second indentations, towards the inner and outer layers of the lens, as seen in FIGS. 12a and 12b, so as to attract the magnetic surfaces 33 7 of the frame pieces.

[0076] The preferred method of attaching the lenses 5 to the bridge bar 32 is illustrated in FIG. 12b, where the magnets secured to the bridge bar 33 are located in the slot 48 of the bridge bar 32, furthest from the edge of the bridge bar 32. This slot 48 will preferably be closest to the inner corners of the lenses 5 when the forces of the magnets in the bridge bar 33 pull the opposing magnets in the inner corners of the lenses 8 towards the bridge bar magnets 33. The attractive forces of the magnets increase when the magnets are close to each other and prevent the three-piece mount from unlinking.

[0077] In another embodiment of the three-piece mount, the lenses 5 can be encompassed by metal around the edge of the lens, with at least one magnet located in the bridge bar 32 only. In such an embodiment, there is no need for magnetic members in the temple pieces. In another embodiment, the bridge bar 32 can be metal with at least one magnet secured to the lens 5.

[0078] As illustrated in FIG. 12c, each temple or endpiece and bridge bar 32, includes a magnet or magnetic material 33, on a first end, closest to the outer corner or edge of each lens 5. The magnets attached to the temple or endpieces 31 or bridge bar 32 protrude towards the outer corners of the lenses 5 for attracting the corresponding magnets embedded in the lenses 5. This reaction is similar to the reaction between the magnets in the bridge bar and the magnets at the inner corners of the lenses 5. This variation can also be achieved in the opposite direction, with the magnet or protrusion in the rear of the lens 5.

[0079] As seen in FIG. 12b and 12e, it is possible for the magnets or magnetic material 33 in the temple endpieces 31 to be positioned at the base of the endpieces 31, towards the furthest end of the slot 48 with respect to the lenses 5. Lenses 5 have magnets 8 attached to the outermost edge of the recess towards the endpiece. Upon insertion of lenses into endpieces, magnets 8 and 33 pull themselves together, securing lenses 5 into endpieces 31. A complimentary configuration can be at the bridge and lens locations, 32 and 30. In other

words, the magnets 33 are positioned on either the upper or lower portion of the recess, towards the first end, closest to the lenses 5.

[0080] Another embodiment of the invention is a magnetic rimlock closure, illustrated in FIG. 13. In this attachment method, magnets 35 are secured to the rims 36 of the frames 34 in the distal corners, at the side opposite the brow bar. Specifically, the magnets are attached at the site where the frames 34 are generally locked—the rimlock. This is also the location where the temple pieces 37 are connected to the rims 36. In the present invention, the magnet replaces the screw as the locking feature. In a conventional rimlock, as in the present invention, the upper and lower sections of the frame separate at the temple corners. In a conventional rimlock, a screw connects the upper and lower sections. At the junction of the upper and lower sections of the frame, the magnets 35 are applied to the ends of the frames 34. The magnetic rimlock eliminates the need for a screw to lock the frames 34 at this junction because the magnetic forces secure the ends of the frame. Since the magnets 35 are attached to both ends of the frame, it is possible to use this magnetic rimlock method with frames of any suitable shape, including, but not limited to, a round or v-shaped eye wire. In this embodiment, it is not necessary that the lenses have magnets embedded therein. The lenses may be received in a recess in the rims of the frames 34 and held securely in place upon the closing and magnetic locking of the rimlock. Persons of skill in the art will appreciate that the rimlock can also be at the nasal bridge portion of the frame and not only at the temple or endpiece portion of the frame.

[0081] Another embodiment of the magnetic attachment method of the present invention is the combination of a magnet with a non-magnetic pin 38 as illustrated in FIGS. 14a-c. It is possible to attach a non-magnetic pin 38 to the upper substantially arcuate surface of the lens, as seen in FIG. 14a. This pin 38 would be received in a frame 1 having a slot 39 or channel, such as the frame 1 in FIG. 14c. The lens 5 is supplied with a magnet 8 on its inner surface, closest to the brow bar, for coupling to a magnet embedded in the frame 1. The lens 5 is also secured to the frame 1 with a slide pin 38, as seen in FIG. 14c, which moves into a slot 39 in the frame 1 for securing the lens 5. The pin 38 can be a substantially T-shaped pin that would lock into place when the lens 5 is positioned into the frame 1.

[0082] The magnets or magnetically attractive material described in the above methods of attachment can be formed of any suitable magnetic material known in the art and may be contoured and shaped in any manner. The magnets are typically lightweight so as not to

burden the user with heavy frames. As seen in FIGS. 15a-15h, the magnets can be any shape, including, but not limited to, trapezoid (FIG. 15a), rectangle (FIG. 15b), round (FIG. 15c), crescent (FIG. 15d), square (FIG. 15e), v-shape (FIG. 15f), and triangle (FIG. 15g).

[0083] In all of the described embodiments, the magnets or magnetically attractive material may be embedded into the lenses and the frames, glued into the lenses or the frames, pressed and expansion-fit into the lenses and the frames, or fitted into the lenses and frames by any other suitable method.

[0084] Further, turning to FIG. 15h, the magnets can be received by channels, or recesses, for coupling to opposing magnetic surfaces. It is also possible to use the magnets as surfaces for restrictive substances, such as glue, so the magnet can be secured to lenses or frames.

[0085] FIG. 16a shows the present invention in a goggle embodiment. Magnets or elements of magnetic material **8** are secured to a shield-style lens **40** suitable for mounting in a goggle-style frame **41**. Oppositely charged magnets or magnetic material **7** are secured to the goggle-style frame **41**. The oppositely charged magnets or magnetic material **7** in the goggle-style frame **41** are placed so that the magnets or magnetic material **8** in the shield-style lenses align with the magnets **7** in the frame **41** when the lens **40** is mounted to the frame **41**. The attractive forces between the magnets or the magnets and magnetic material couple the lens to the frame. Those skilled in the art will appreciate that securing the magnets **7** in a groove or recess **6** in the frame **41** will assist in securing a lens to the frame **41**. The groove or recess **6** may be sized to securely accept the lens thereby holding it in place, as shown in FIG. 16b. FIG. 16b shows a cross-section of a goggle frame with double-lenses mounted in the frame.

[0086] While FIG. 16a shows magnets or magnetic material **8** secured to the sides of the shield-style lens **40**, those skilled in the art will appreciate that magnets or magnetic material could be secured to any portion of a shield-style lens **40** as long as the magnets or magnetic material secured to the lens correspond in location to magnets or magnetic material secured to the frame. Those skilled in the art will also appreciate that lens styles other than shield-style lenses may be secured to a goggle-style frame through the use of magnets in accordance with the present invention. An example of such a lens style is shown in FIG. 16c. Those skilled in the art will also appreciate that one lens of any style may be permanently attached to the frame with or without magnets while a second lens of any style may be releaseably attached

to the same frame using magnets according to the present invention. It may be desirable to combine shield-style lenses with conventionally shaped lenses in a goggle style frame.

[0087] FIG. 17a shows another embodiment of the present invention. A lens 5 is surrounded by a wire 42 on the edge 9 of the lens 5. A wire 42 may also be used as magnetic material so that coupling the lens to the frame may be accomplished by securing at least one magnet to the frame and no magnets to the lens. In an alternative embodiment, a wire 42 may also wrap over the top of a magnetic member to secure the magnetic member 8 to the lens 5, as shown in FIG. 17b and 17d. FIG. 17b shows another embodiment of the present invention. A wire 42 surrounds a lens 5. A magnet or magnetic material 8 is embedded in the lens 5. Oppositely charged magnets or magnetic material are secured to the frame that the lens is to be mounted to. The oppositely charged magnets in the frame should be placed so that the magnets or magnetic material 8 in the lens align with the magnets in the frame when the lens is mounted to the frame. The attractive forces between the magnets or the magnets and magnetic material couple the lens to the frame. Those skilled in the art will appreciate that a wire 42 may also be embedded in a groove in the lens as shown in FIG. 17c. Those skilled in the art will also appreciate that a wire may also be used to snap into the frame to assist the magnetic attractive forces in securing the lens to the frame.

[0088] While various embodiments have been chosen to illustrate the invention, it will be understood by those skilled in the art that various changes and modifications can be made therein without departing from the scope of the invention as defined in the appended claims.

THE CLAIMS DEFINING THE INVENTION ARE AS FOLLOWS:-

1. A lens apparatus for removably mounting a primary lens to an eyeglass frame comprising a lens and at least one lens magnetic member, the lens comprising:
 - 5 a lens front surface having a front circumferential edge;
 - a lens rear surface having a rear circumferential edge spaced a distance from said front circumferential edge;
 - a lens thickness spaced between the front lens surface and the rear lens surface;
 - a lens edge surface spaced between the front circumferential edge and the rear
 - 10 circumferential edge; and
 - a cavity extending through the lens thickness, the cavity having a proximal cavity portion proximal to the circumferential edge and having a first cavity dimension; and
 - the cavity having a distal cavity portion distal from the circumferential edge and
 - 15 having a second cavity dimension, wherein the second cavity dimension is larger than the first cavity dimension;
 - wherein the at least one lens magnetic member comprises:
 - a magnetic member front surface;
 - a magnetic member rear surface;
 - 20 a magnetic member edge surface; wherein
 - a first portion is sized to fit within the first cavity portion; and
 - a second portion is sized to fit within the second cavity portion,
 - wherein the magnetic member front surface is substantially flush with the lens front surface, the magnetic member rear surface is substantially flush with the lens rear
 - 25 surface and the magnetic member edge surface is substantially flush with the lens edge surface.
2. The lens apparatus of claim 1 wherein the primary lens is a prescription lens.
3. The lens apparatus of claim 2 wherein the primary lens is clear.
4. The lens of claim 2 wherein the primary lens is tinted.
- 30 5. The lens apparatus of claim 1 wherein the primary lens is a plano lens.

6. The lens apparatus of claim 5 wherein the lens is clear.
7. The lens apparatus of claim 5 wherein the lens is tinted.
8. An eyeglass assembly comprising a primary eyeglass frame adapted for removable mounting of a primary lens thereto, the assembly further comprising:
- 5 at least one primary lens having a front surface, a rear surface, a circumferential edge thickness, an edge surface, and at least one lens cavity extending through the circumferential edge thickness, the at least one lens cavity having a proximal cavity portion proximal to the circumferential edge and having a first lens cavity dimension, and a distal cavity portion distal to the circumferential edge and having a second lens
- 10 cavity dimension larger than the first lens cavity dimension;
- a primary eyeglass frame comprising at least one partial lens rim portion comprising:
- a front frame portion having a front frame surface,
- a rear frame portion separated a distance from and opposing the front frame
- 15 surface,
- a connecting frame portion connecting the front frame portion and the rear frame portion, the connecting portion comprising:
- a mounting surface; and
- at least one frame cavity extending through the connecting frame portion, the at
- 20 least one frame cavity having a first frame cavity portion proximal to the mounting surface having a first frame cavity dimension, and a second frame cavity portion distal from the mounting surface having a second frame cavity dimension larger than the first frame cavity dimension;
- at least one lens magnetic member configured to engage the at least one lens
- 25 cavity such that a lens magnet front surface is substantially flush with the lens front surface, a lens magnet rear surface is substantially flush with the lens rear surface and a lens magnet edge surface is substantially flush with the lens edge surface; and
- at least one frame magnetic member configured to engage the at least one frame cavity such that at least a portion of a frame magnetic member edge surface is
- 30 substantially flush with the mounting surface.

9. A lens apparatus for removably mounting a primary lens to an eyeglass frame comprising a lens and at least one lens magnetic member, the lens comprising:
a lens front surface having a front circumferential edge;
a lens rear surface having a rear circumferential edge spaced a distance from said
5 front circumferential edge;
a lens thickness spaced between the front lens surface and the rear lens surface;
a lens edge surface spaced between the front circumferential edge and the rear
circumferential edge; and
a cavity extending at least partially through the lens thickness, the cavity having
10 a proximal cavity portion proximal to the circumferential edge and having a first cavity
dimension; and the cavity having a distal cavity portion distal from the circumferential
edge and having a second cavity dimension, wherein the second cavity dimension is
larger than the first cavity dimension;
wherein the at least one lens magnetic member comprises:
15 a magnetic member front surface;
a magnetic member rear surface;
a magnetic member edge surface; wherein
the lens magnet having first portion with a first magnet dimension sized to fit
within the first cavity portion and a second lens magnet portion sized to fit within the
20 second cavity portion such that the lens magnetic member front surface is substantially
flush with the lens front surface, the magnetic member rear surface is substantially flush
with the lens rear surface and the magnetic member edge surface is substantially flush
with the lens edge surface.

10. The lens apparatus according to claim 9, wherein the cavity is generally trapezoidal
25 in shape.

11. An eyeglass assembly comprising a primary eyeglass frame adapted for removable
mounting of a primary lens thereto, the assembly further comprising:
at least one primary lens having a front surface, a rear surface, a circumferential
edge thickness, an edge surface, and a lens cavity extending at least partially through
30 the circumferential edge thickness,

the lens cavity having a proximal cavity portion proximal to the circumferential edge and having a first lens cavity dimension, and a distal cavity portion distal to the circumferential edge and having a second lens cavity dimension larger than the first lens cavity dimension;

5 a primary eyeglass frame comprising at least one partial lens rim portion;
wherein the at least one lens magnetic member comprises:

- a magnetic member front surface;
- a magnetic member rear surface;
- a magnetic member edge surface; wherein

10 the lens magnet having a first portion with a first magnet dimension sized to fit within the first lens cavity portion and a second lens magnet portion sized to fit within the second cavity portion such that the lens magnetic member front surface is substantially flush with the lens front surface, the magnetic member rear surface is substantially flush with the lens rear surface and the magnetic member edge surface is
15 substantially flush with the lens edge surface.

12. The eyeglass assembly according to claim 11, wherein the lens cavity is generally trapezoidal in shape.

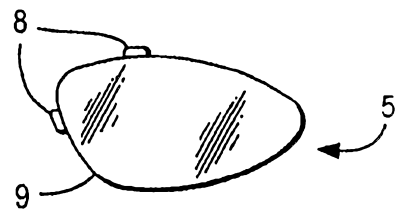
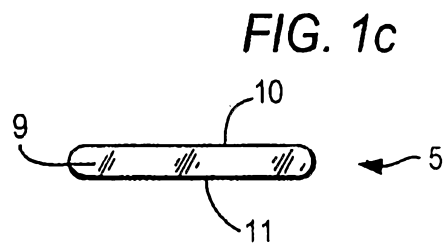
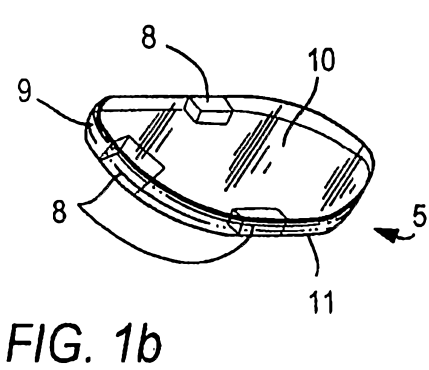
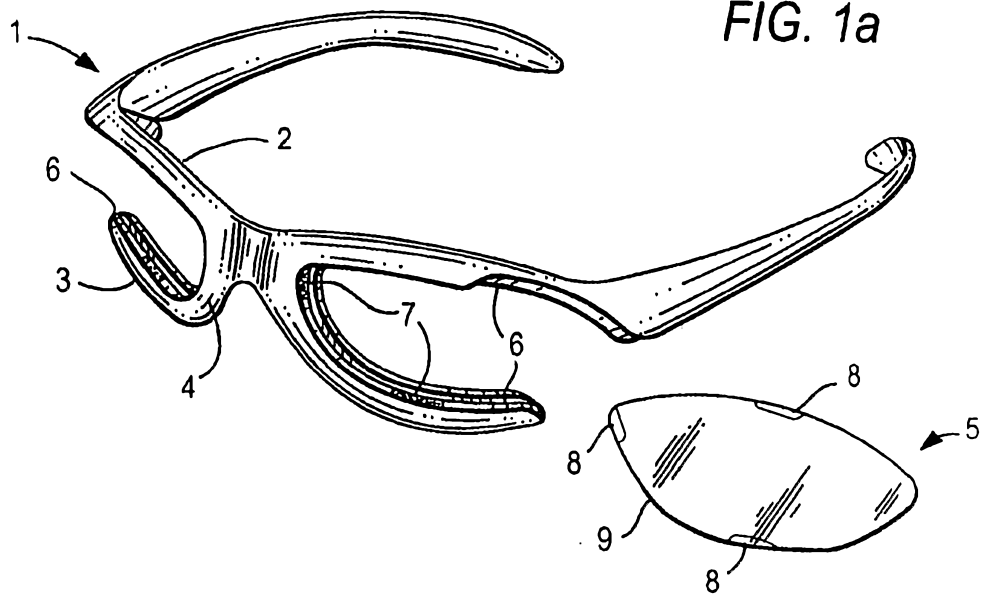

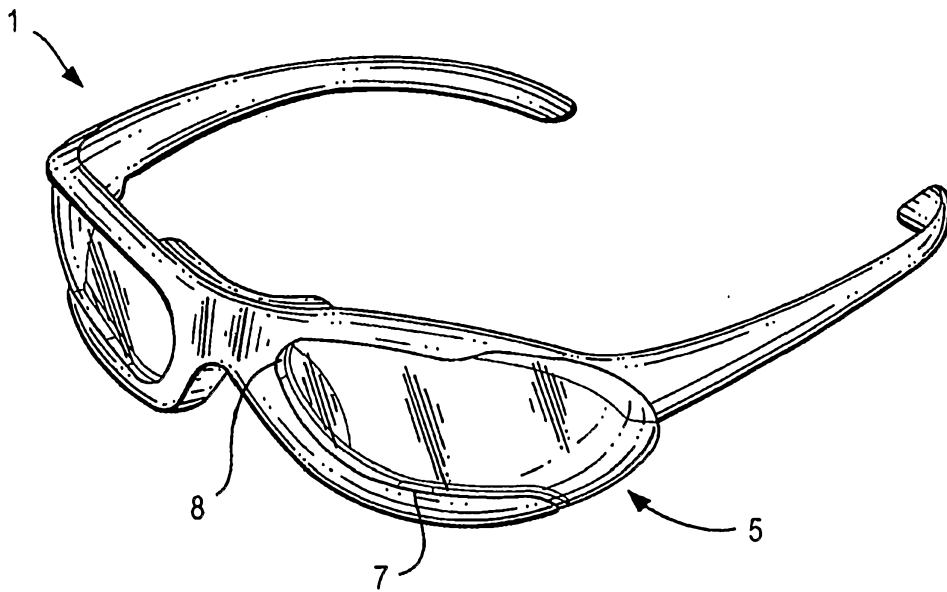

FIG. 2

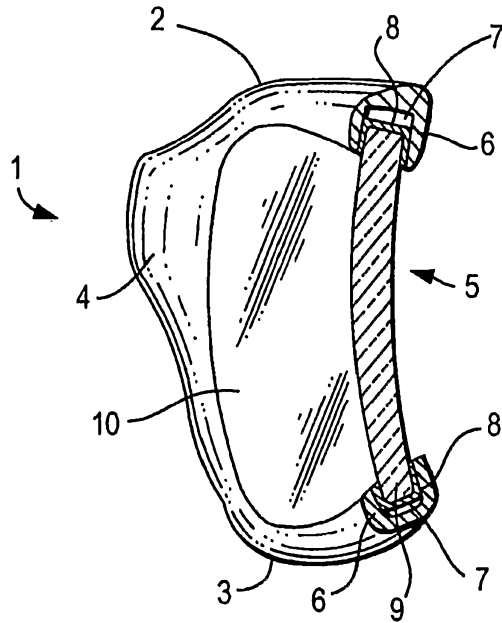

FIG. 3a

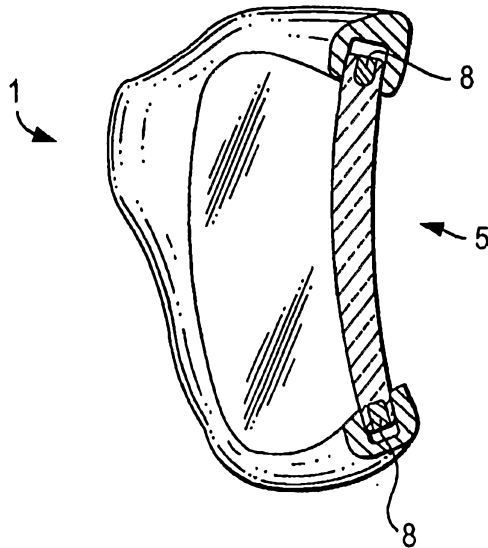

FIG. 3b

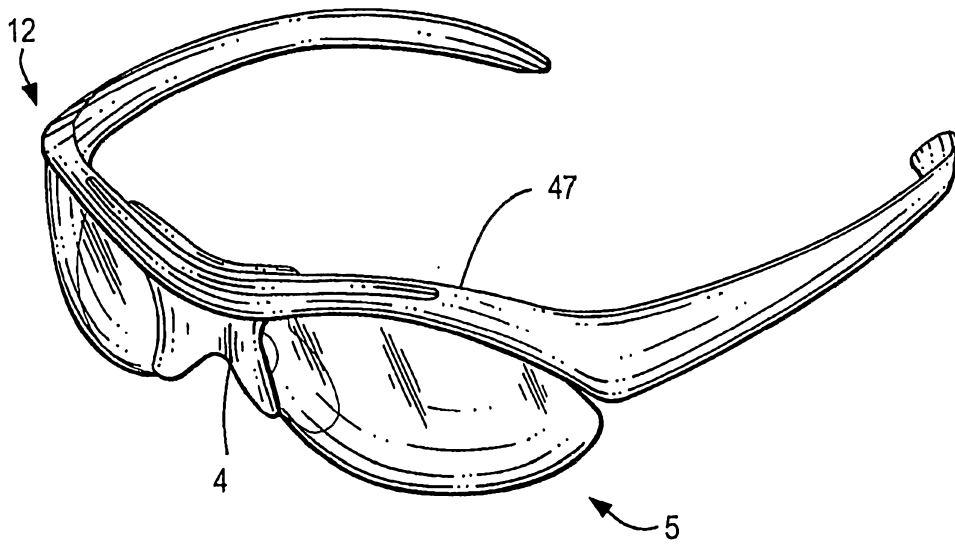

FIG. 4

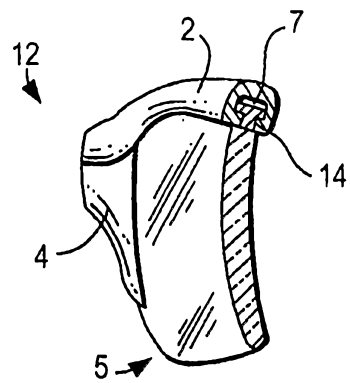
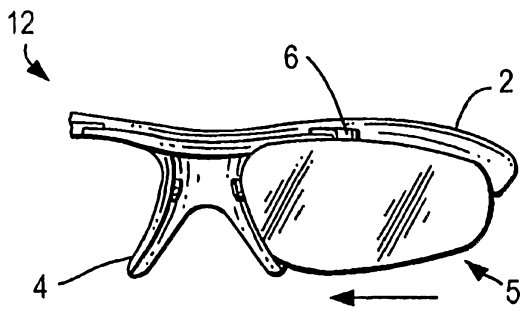
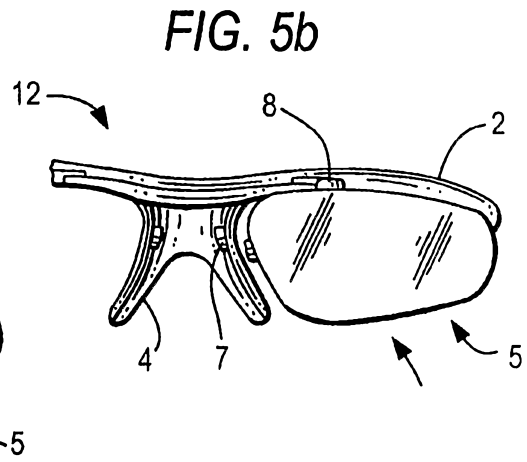
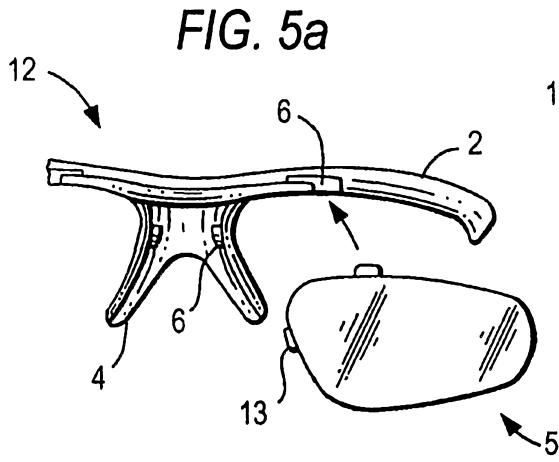

FIG. 5c

FIG. 5d

FIG. 6a

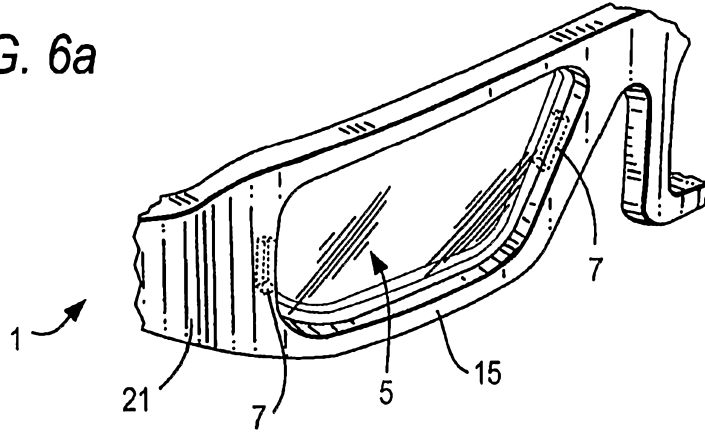

FIG. 6b

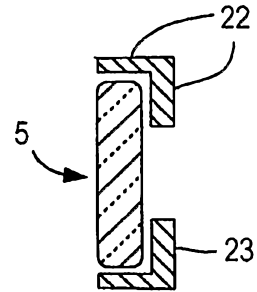
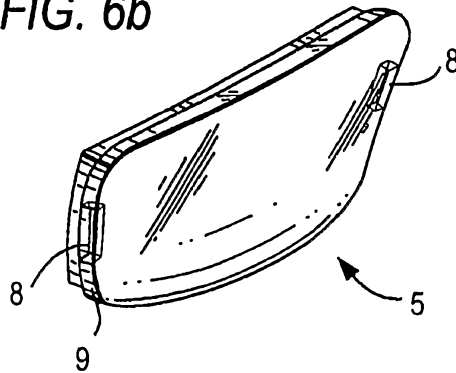

FIG. 6c

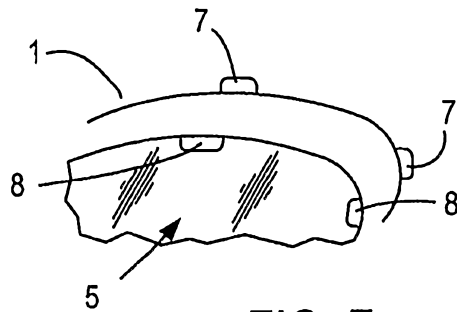

FIG. 7

FIG. 8a

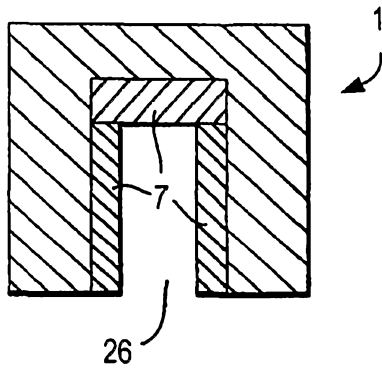

FIG. 8c

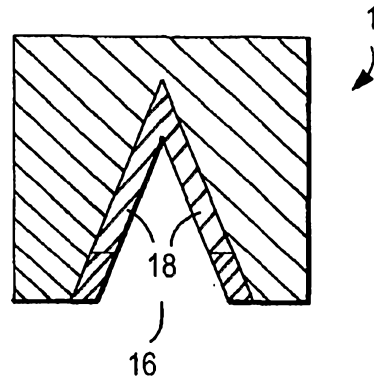

FIG. 8b

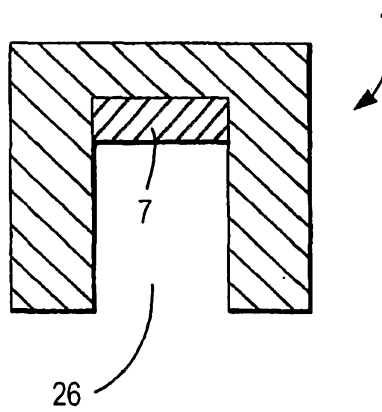
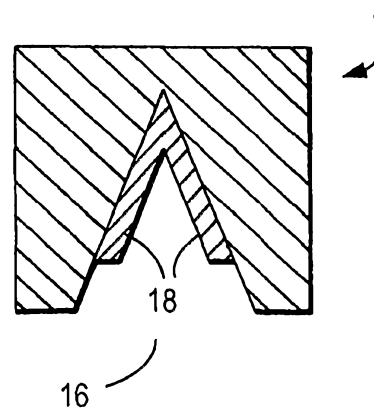

FIG. 8d



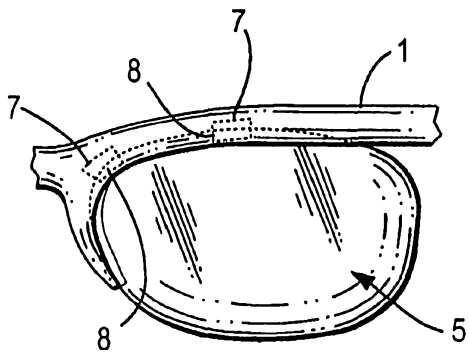
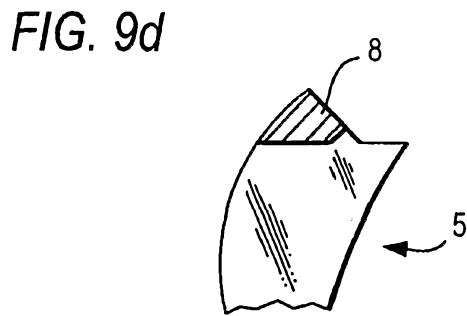
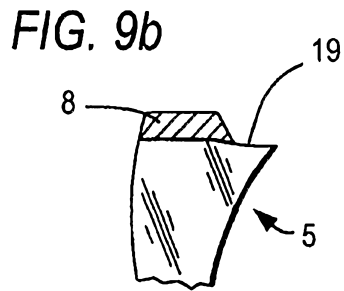
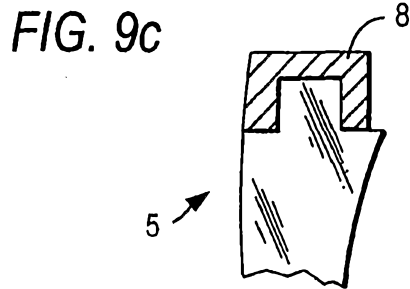
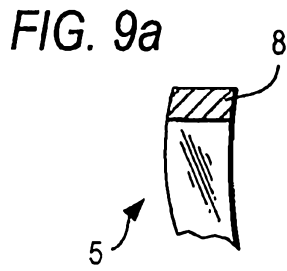

FIG. 10a

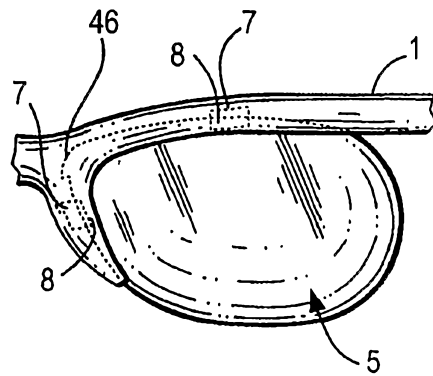

FIG. 10b

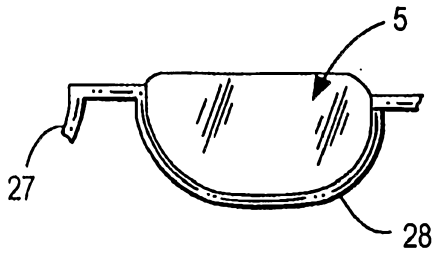

FIG. 11a

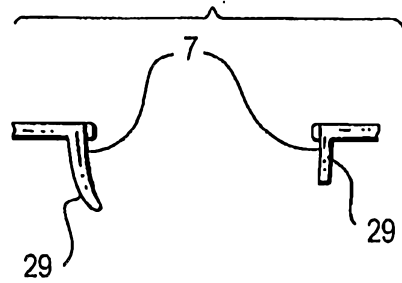

FIG. 11b

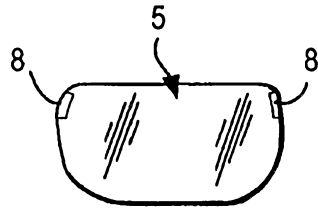

FIG. 11c



FIG. 11d

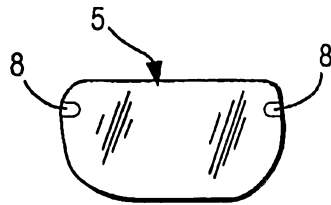
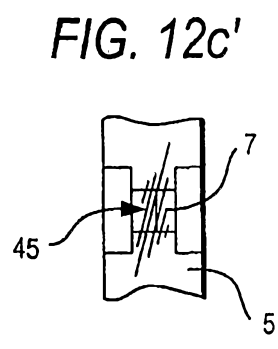
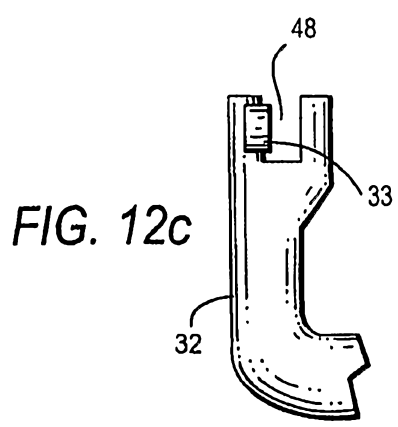
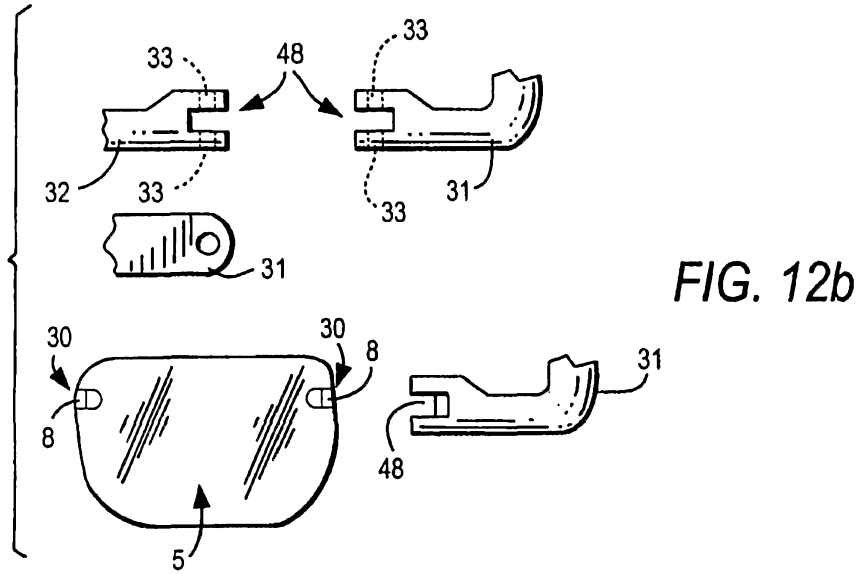
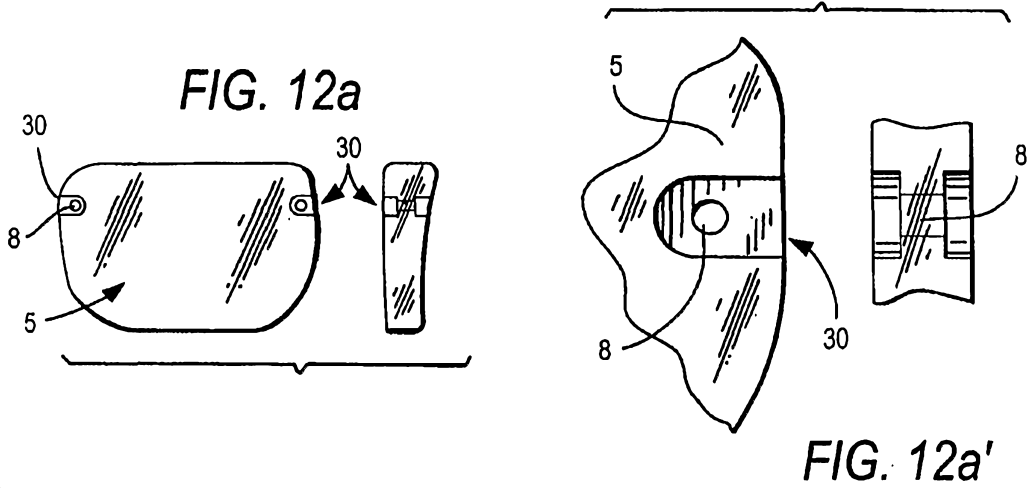
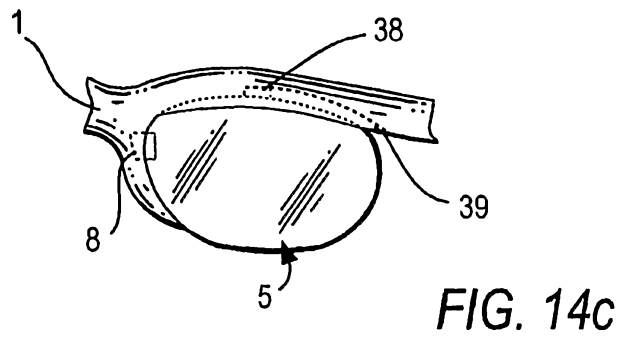
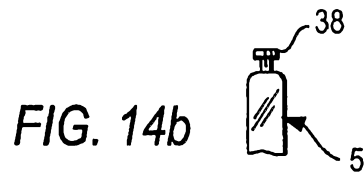
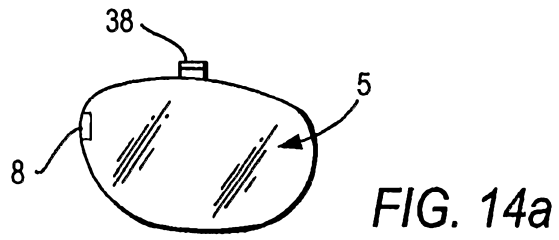
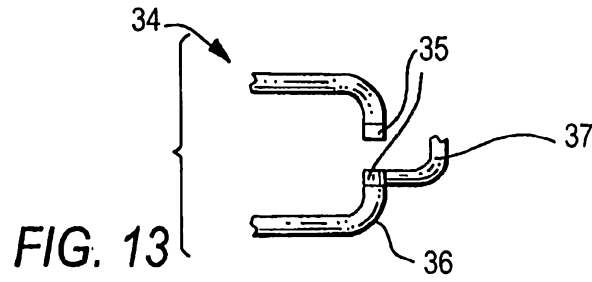

FIG. 11e





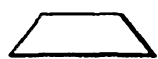

FIG 15a

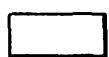

FIG 15b



FIG 15c



FIG 15d



FIG 15e



FIG 15f



FIG 15g



FIG 15h

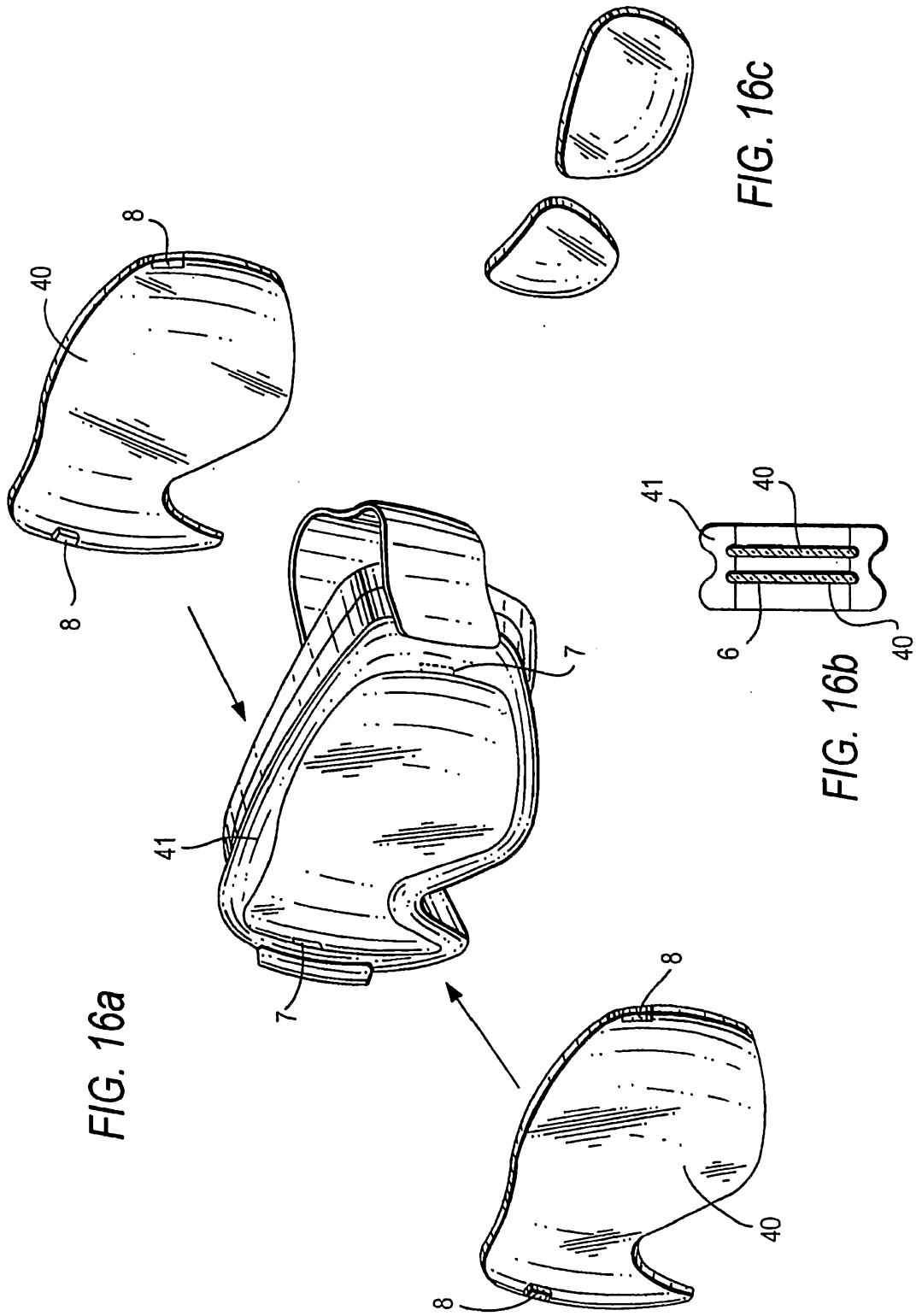

FIG. 16a

FIG. 16c

FIG. 16b

