



US 20140079590A1

(19) **United States**

(12) **Patent Application Publication**

Rossi et al.

(10) **Pub. No.: US 2014/0079590 A1**

(43) **Pub. Date: Mar. 20, 2014**

(54) **PERFUSION SYSTEM WITH RFID FEATURE ACTIVATION**

(71) Applicant: **SORIN GROUP ITALIA, S.R.L.**,  
Milano (IT)

(72) Inventors: **Ivan Rossi**, Poggio Rusco (IT);  
**Raffaella Bombarda**, Carpi (Modena)  
(IT)

(73) Assignee: **SORIN GROUP ITALIA, S.R.L.**,  
Milano (IT)

(21) Appl. No.: **13/622,634**

(22) Filed: **Sep. 19, 2012**

**Publication Classification**

(51) **Int. Cl.**  
*A61M 1/10* (2006.01)  
*G06F 21/00* (2006.01)  
*A61M 1/32* (2006.01)  
(52) **U.S. Cl.**  
CPC ..... *A61M 1/1086* (2013.01); *A61M 1/10*  
(2013.01); *A61M 1/32* (2013.01); *G06F 21/00*  
(2013.01)  
USPC ..... **422/45**; 604/151; 340/5.6

(57) **ABSTRACT**

The disclosure pertains to a perfusion system that is easy to set-up, use and monitor during a bypass procedure. In some embodiments, the disclosure pertains to a perfusion system in which at least some of the disposable components used with the perfusion system are configured to be able to communicate set-up and/or operational parameters to the perfusion system in order to unlock further functionality within the perfusion system.

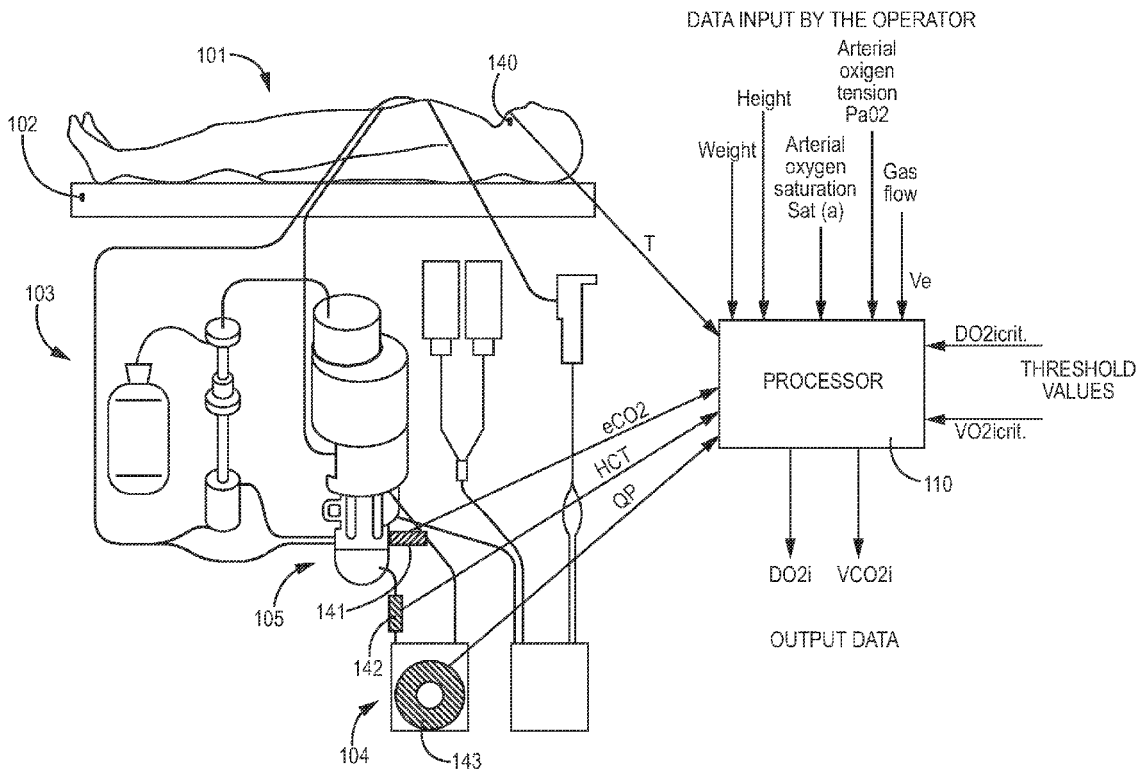

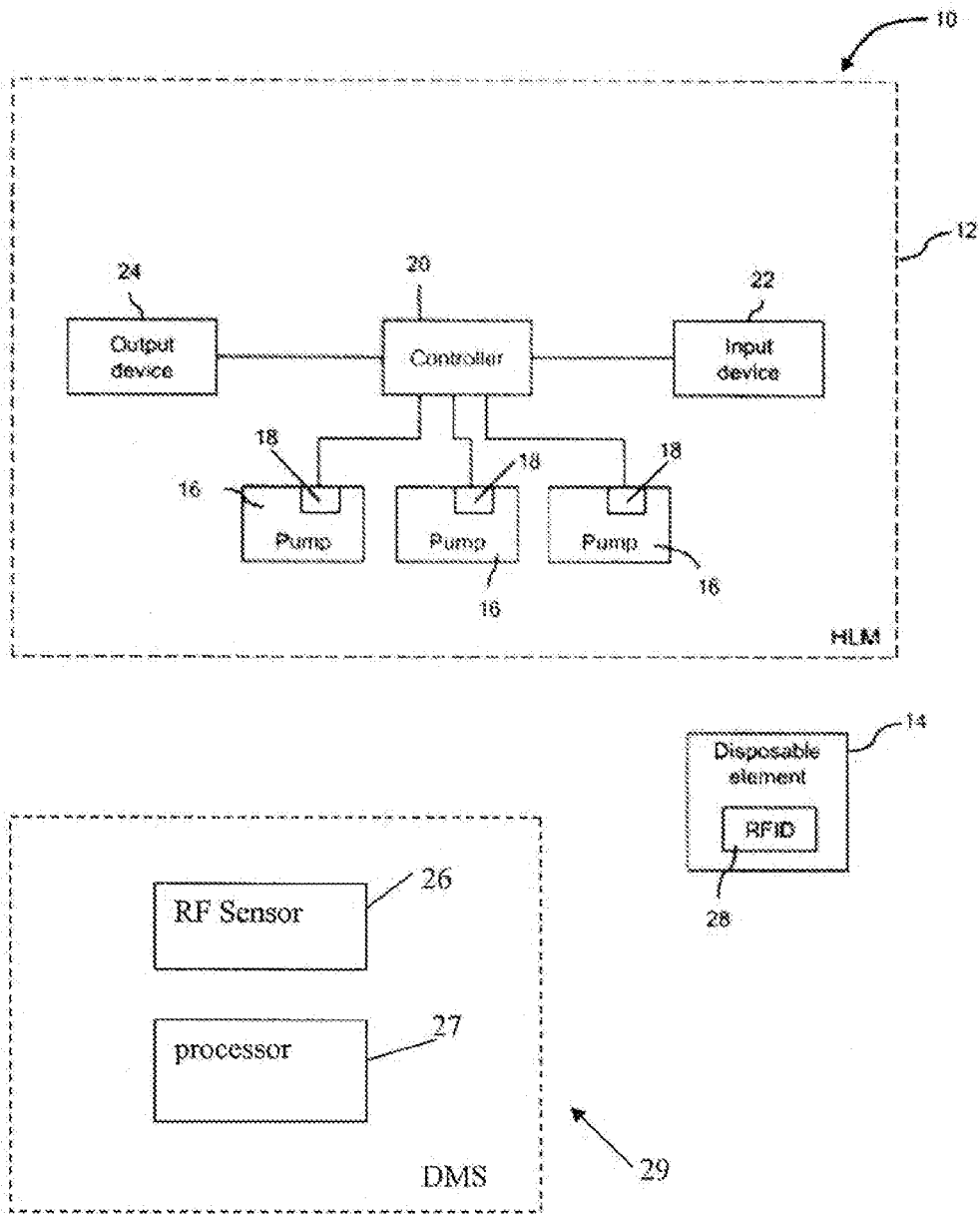

Fig. 1

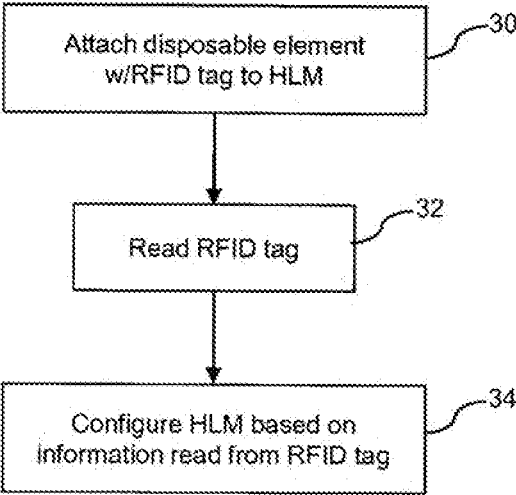

Fig. 2

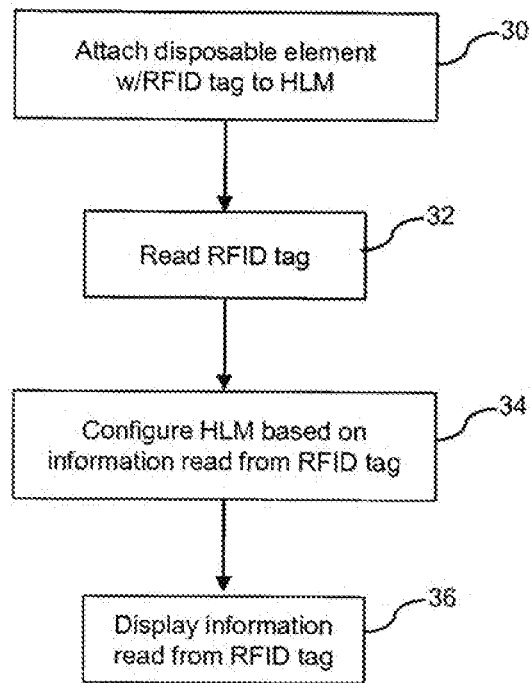

Fig. 3

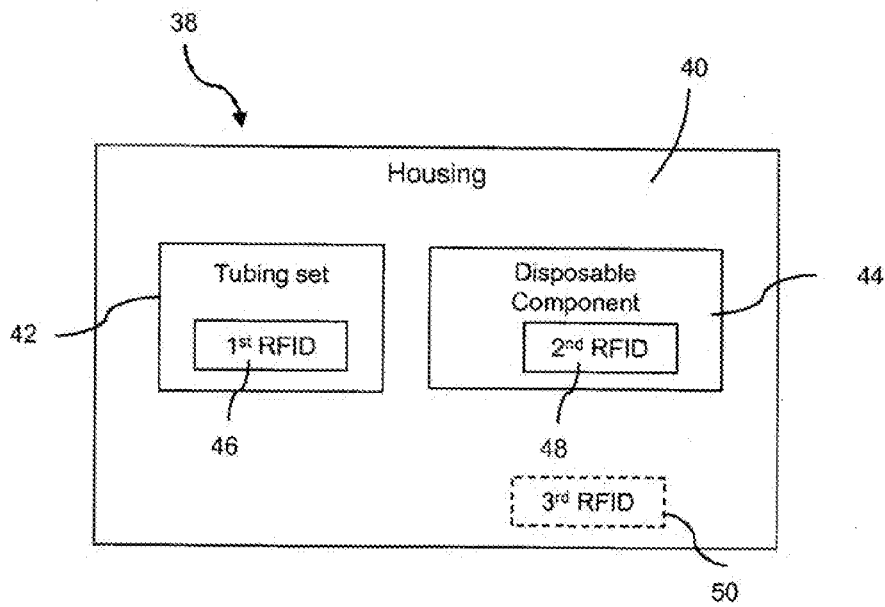

Fig. 4

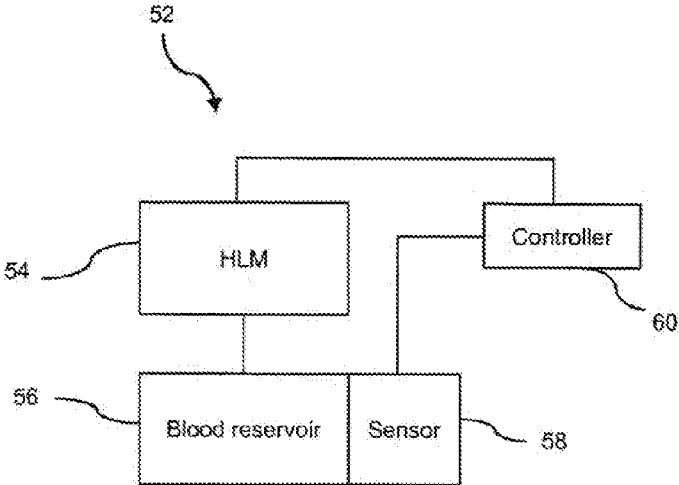

Fig. 5

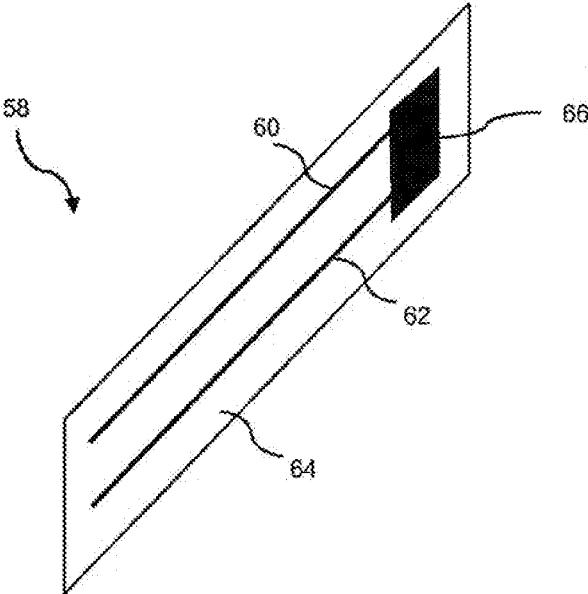

Fig. 6

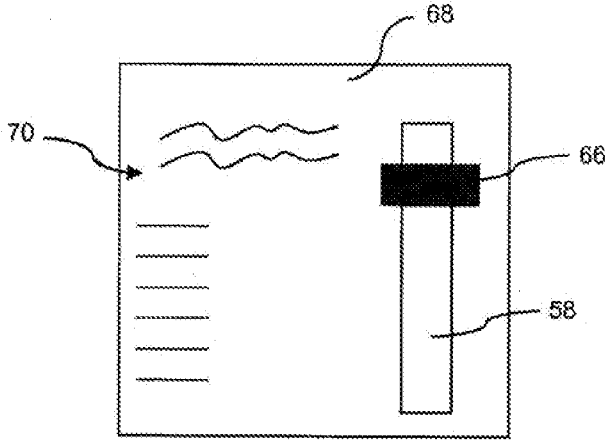

Fig. 7

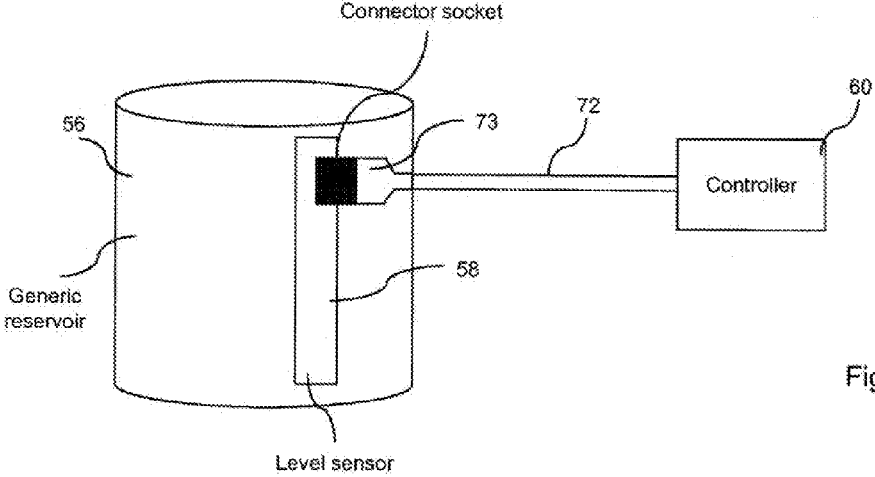

Fig. 8



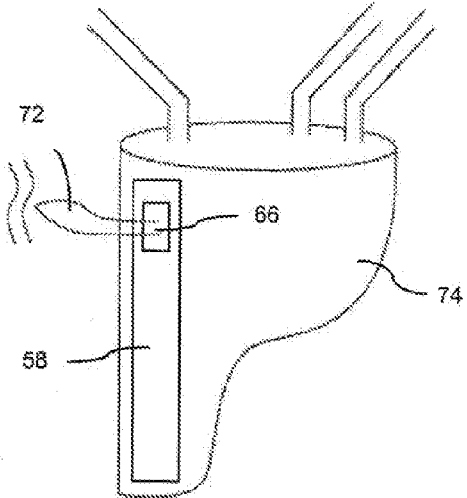

Fig. 9

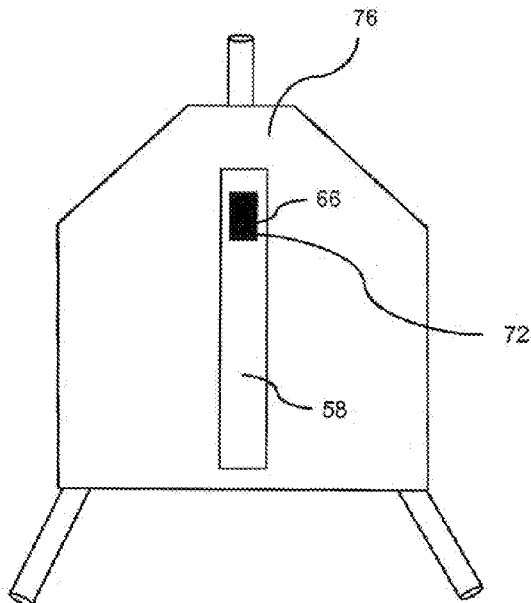

Fig. 10

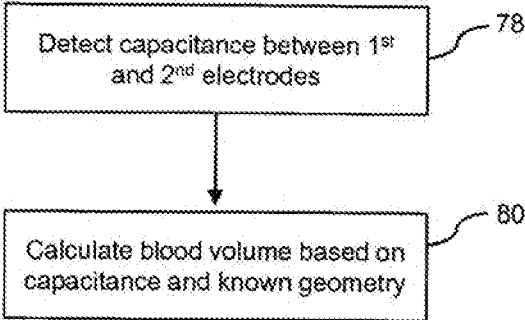

Fig. 11

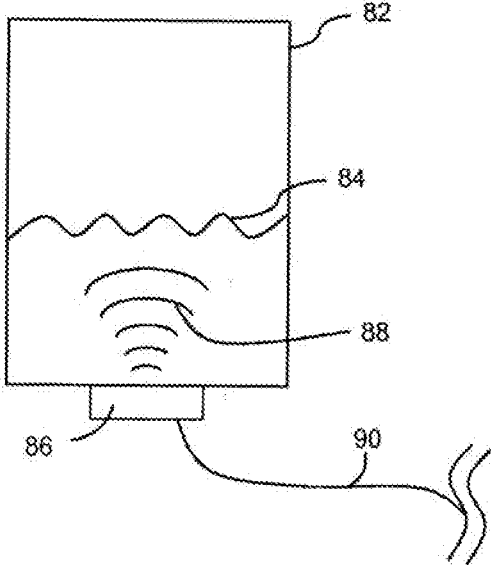

Fig. 12

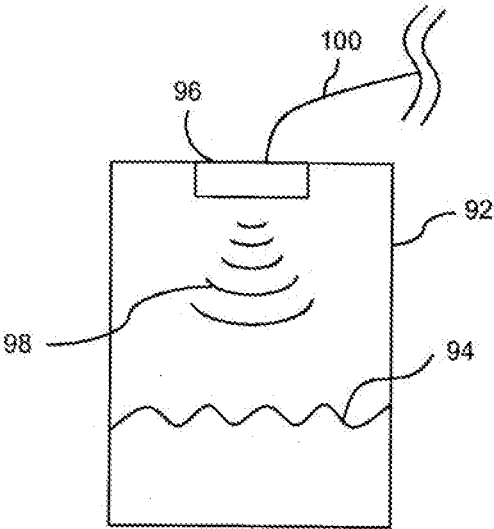

Fig. 13

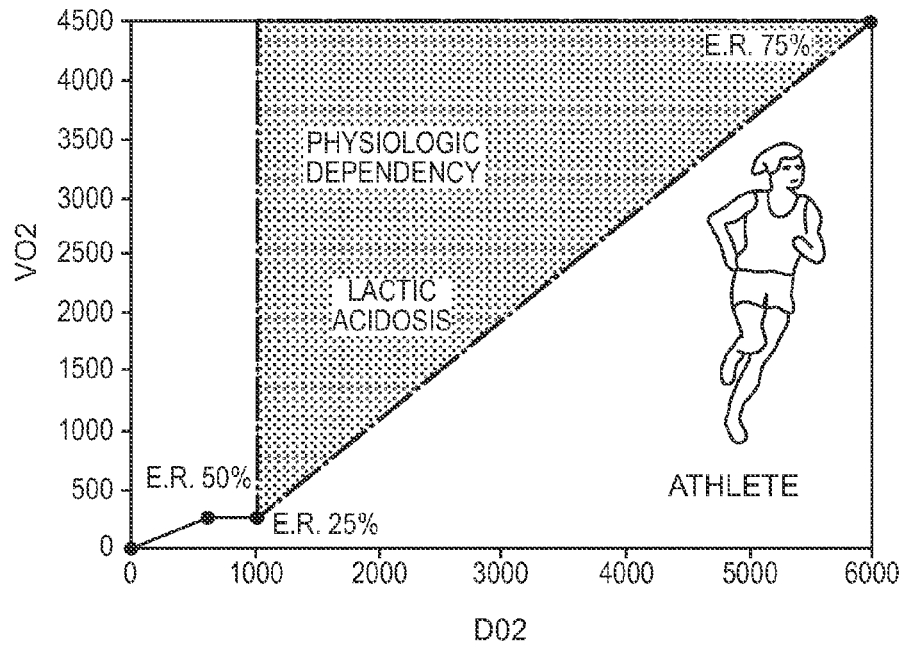

FIG. 14

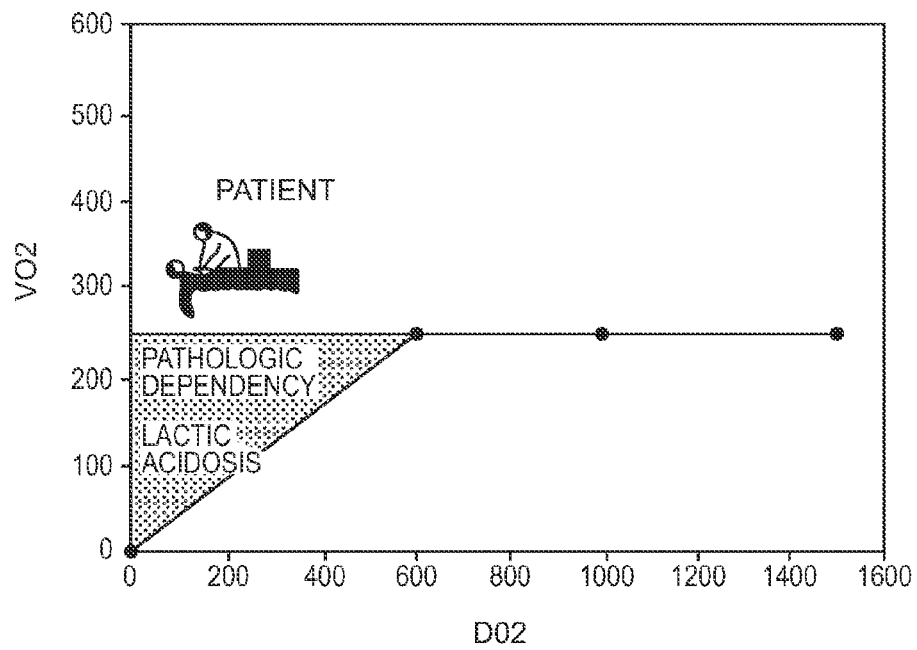

FIG. 15

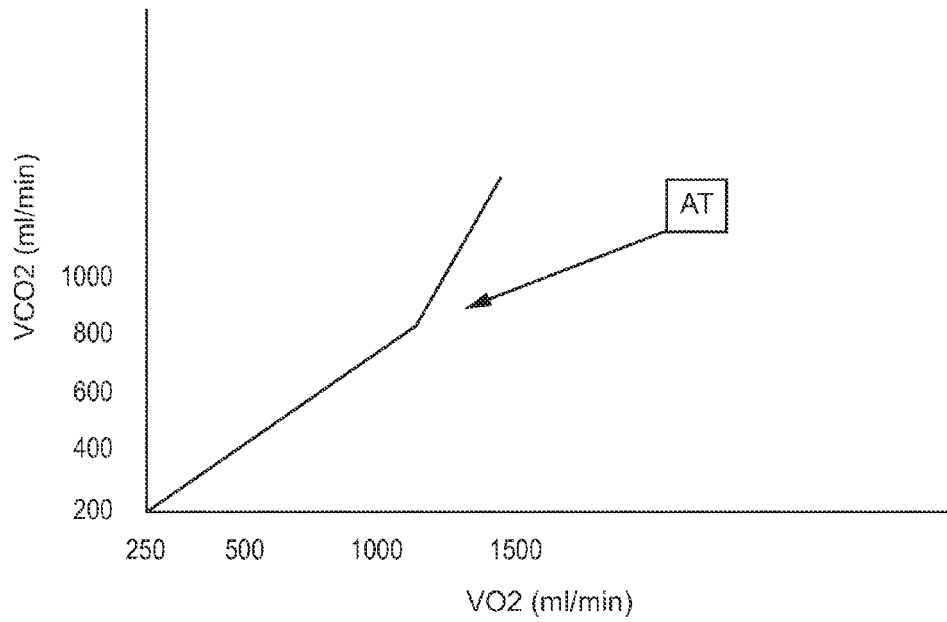

FIG. 16

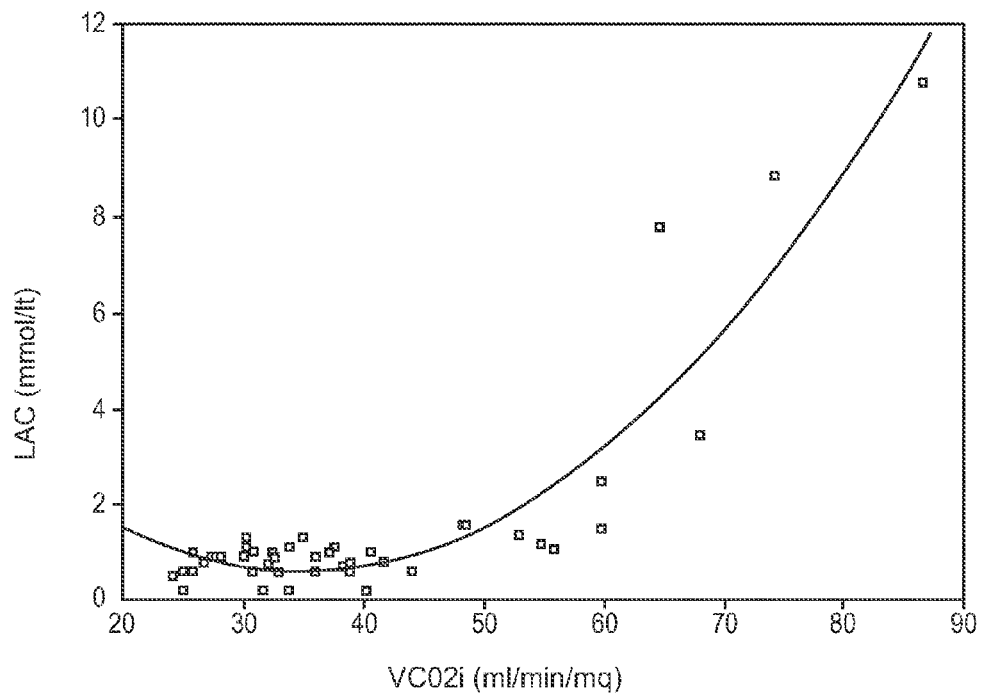

FIG. 17

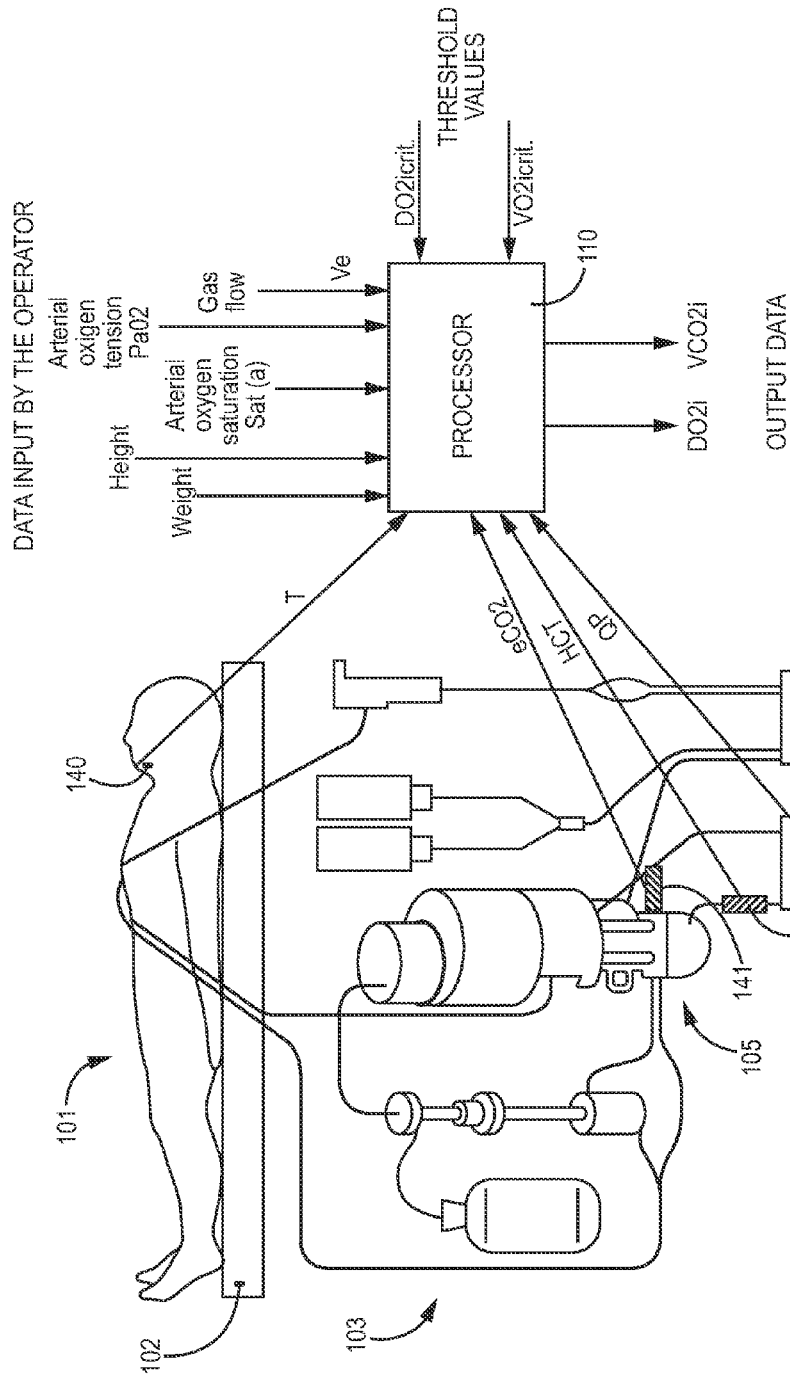

FIG. 18

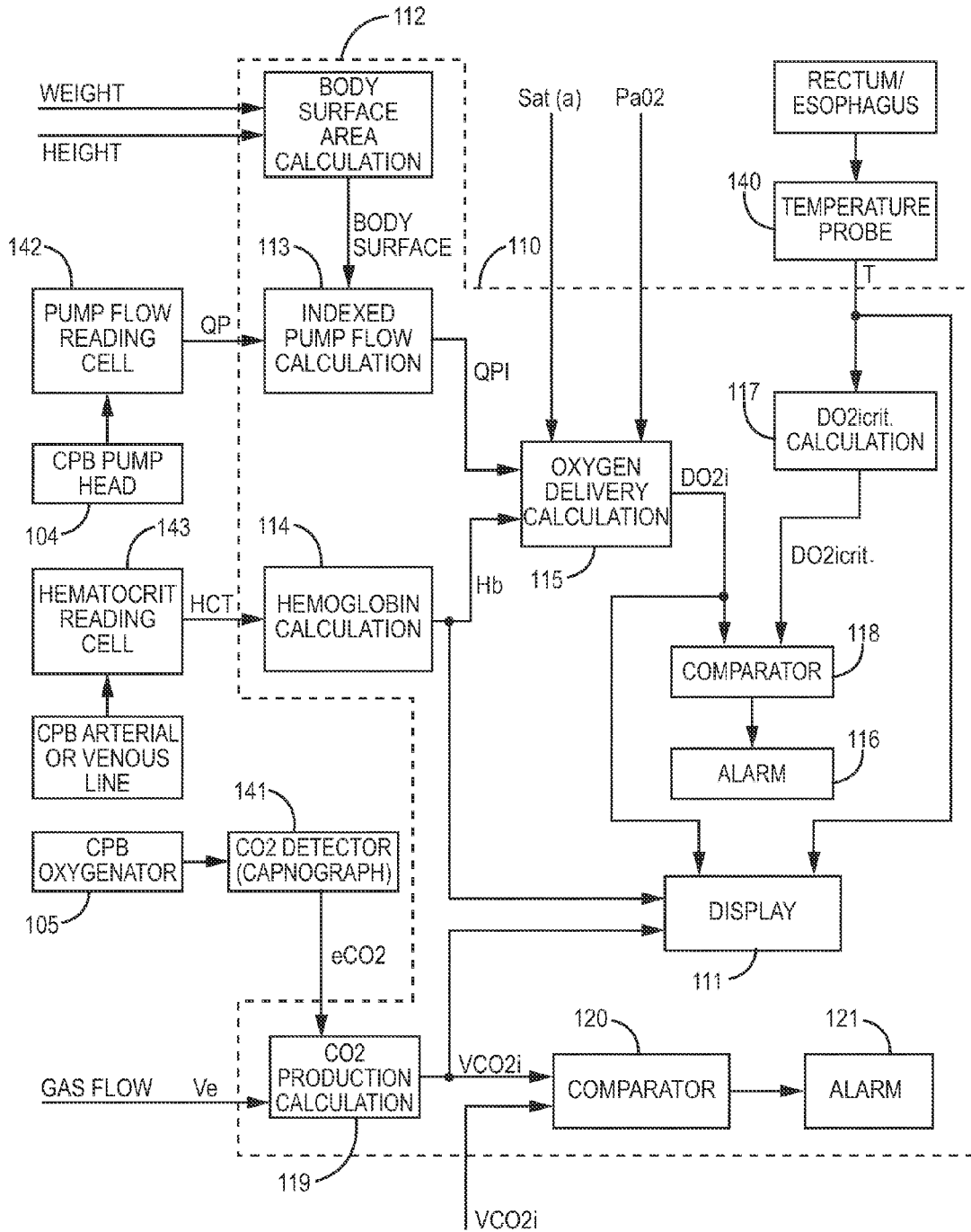

FIG. 19

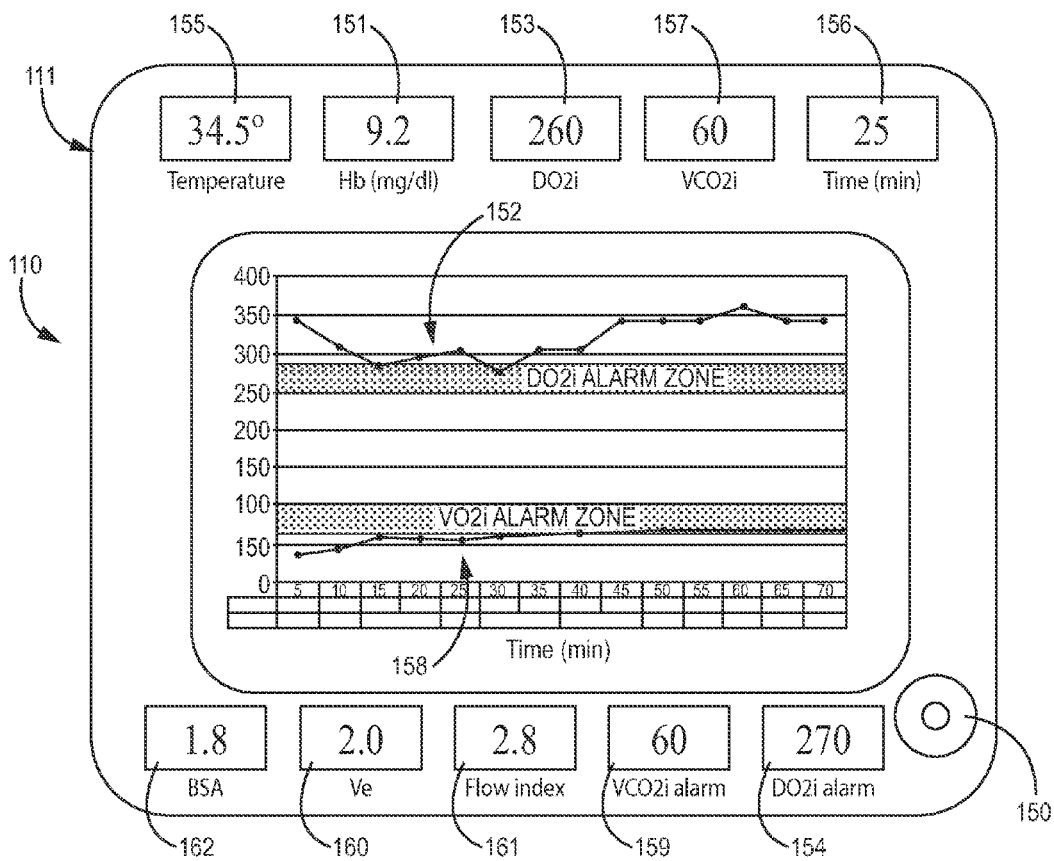

FIG. 20



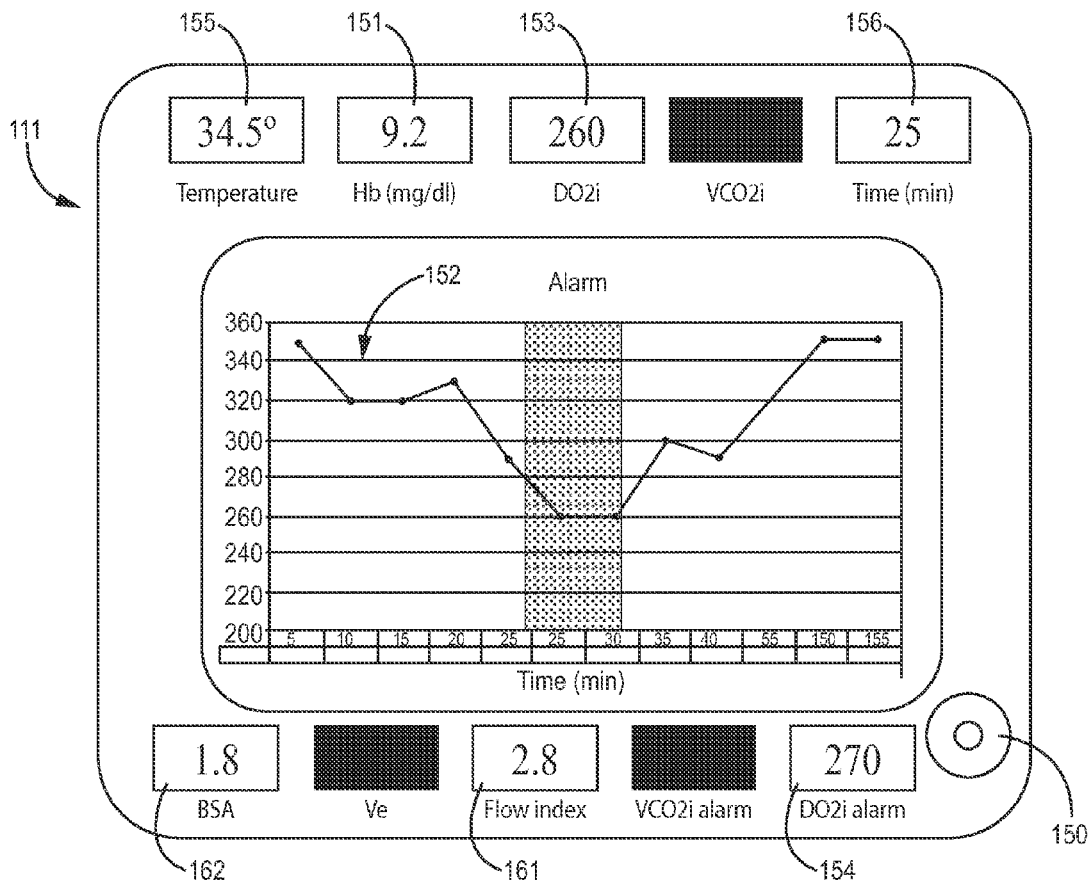

FIG. 21

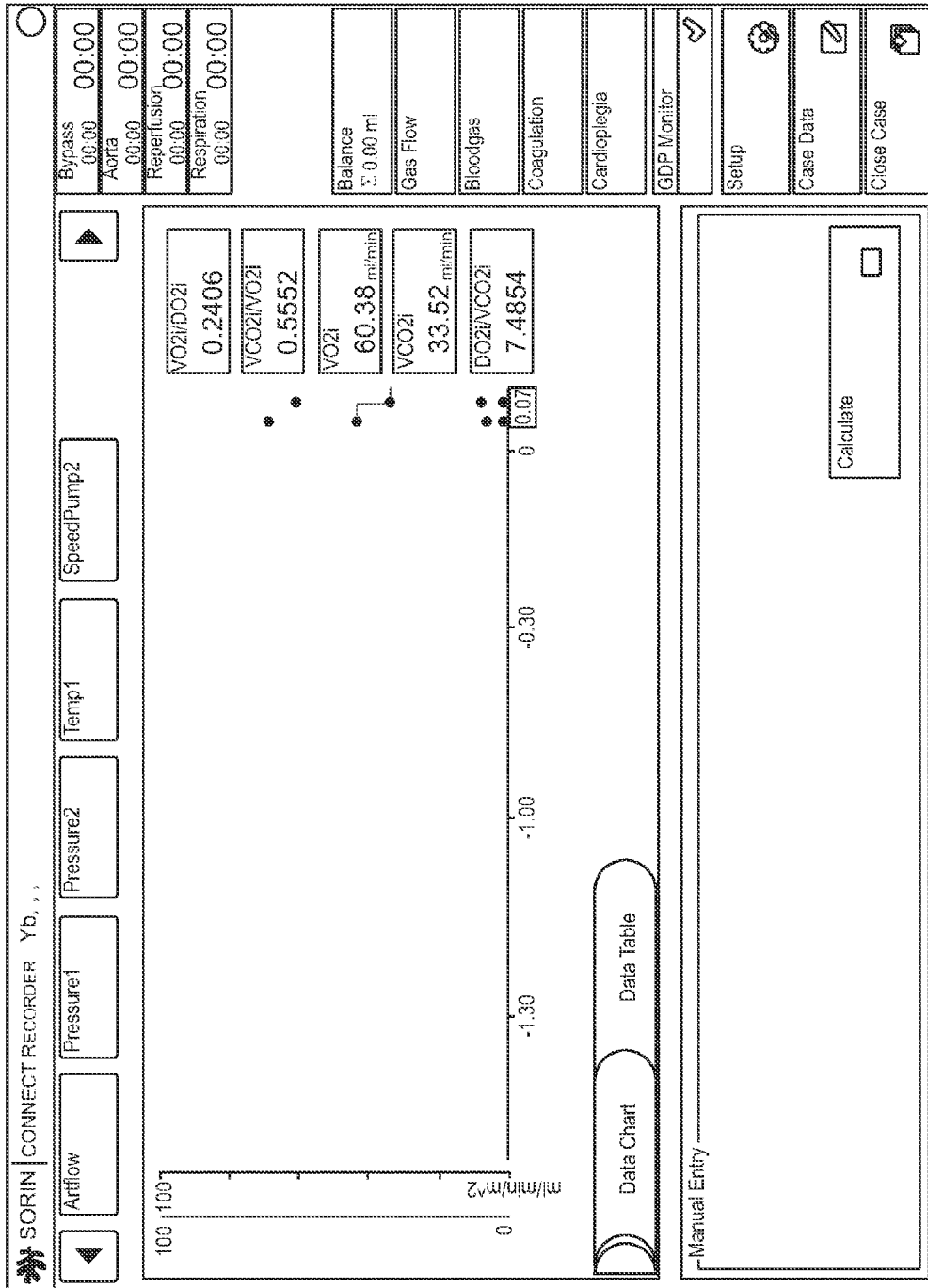

FIG. 22

**Metabolic Algorithm**

Measurement Period: 15:45 15:45:53

CO2exh	36	mmHg	Result	DO2i	269.1057	ml/min/m <sup>2</sup>
Ve	2.2	l/min		VO2i	68.24491	ml/min/m <sup>2</sup>
Qb	4.57	l/min		VCO2i	43.16588	ml/min/m <sup>2</sup>
PaO2	208.7	mmHg		DO2i/VCO2i	6.234224	
SvO2	76	%		VCO2i/VO2i	0.6325142	
Hct	26	%		VO2i/DO2i	0.2535989	
PvO2	44.4	mmHg				
SaO2	98.1	%				
Body Surface Area (BSA): 2.11 m <sup>2</sup>						

FIG. 23

## PERFUSION SYSTEM WITH RFID FEATURE ACTIVATION

### TECHNICAL FIELD

[0001] The disclosure pertains generally to perfusion systems and more particularly to integrated perfusion systems configured to communicate component-specific information between system components.

### BACKGROUND

[0002] Perfusion entails encouraging physiological solutions such as blood through the vessels of the body or a portion of a body of a human or animal. Illustrative examples of situations that may employ perfusion include extracorporeal circulation during cardiopulmonary bypass surgery as well as other surgeries. In some instances, perfusion may be useful in providing extracorporeal circulation during various therapeutic treatments. Perfusion may be useful in maintaining the viability of body parts such as specific organs or limbs, either while the particular body part remains within the body, or while the body part is exterior to the body such as for transplantation or if the body part has been temporarily removed to provide access to other body structures. In some instances, perfusion may be used for a short period of time, typically defined as less than about six hours. In some cases, perfusion may be useful for extended periods of time that are greater than about six hours.

[0003] In some instances, blood perfusion systems include one or more pumps in an extracorporeal circuit that is interconnected with the vascular system of a patient. Cardiopulmonary bypass (CPB) surgery typically requires a perfusion system that allows for the temporary cessation of the heart by replacing the function of the heart and lungs. This creates a still operating field and allows for the surgical correction of vascular stenosis, valvular disorders, and congenital heart and great vessel defects. In perfusion systems used for cardiopulmonary bypass surgery, an extracorporeal blood circuit is established that includes at least one pump and an oxygenation device to replace the functions of the heart and lungs.

[0004] More specifically, in cardiopulmonary bypass procedures, oxygen-poor blood (i.e., venous blood) is gravity-drained or vacuum suctioned from a large vein entering the heart or other veins (e.g., femoral) in the body and is transferred through a venous line in the extracorporeal circuit. The venous blood is pumped to an oxygenator that provides for oxygen transfer to the blood. Oxygen may be introduced into the blood by transfer across a membrane or, less frequently, by bubbling oxygen through the blood. Concurrently, carbon dioxide is removed across the membrane. The oxygenated blood is then returned through an arterial line to the aorta, femoral, or other main artery.

### SUMMARY

[0005] According to an embodiment of the present invention, an integrated perfusion system includes a heart lung machine having a plurality of pump modules, each pump module having a control unit. A controller is in communication with each of the control units. An input device is in communication with the controller and is configured to accept operational settings information from a user. An output device is in communication with the controller and is configured to display operational parameters of the plurality of

pump modules. The integrated perfusion system includes a data management system that is in communication with the controller.

[0006] The data management system includes an RF sensor and a processor in communication with the RF sensor. One or more disposable elements are configured to be used in conjunction with the heart lung machine and include an RFID tag programmed with identifying information that can be read by the RF sensor and used by the processor to unlock functionality within the data management system.

[0007] According to another embodiment of the present invention, an integrated perfusion system includes a heart lung machine and a data management system, the data management system including an RF sensor. The integrated perfusion system may be configured by attaching a disposable component having an RFID tag to the heart lung machine, reading the RFID tag with the RF sensor, unlocking functionality within the data management system in accordance with information read from the RFID tag, and operating the unlocked functionality.

[0008] While multiple embodiments are disclosed, still other embodiments of the present invention will become apparent to those skilled in the art from the following detailed description, which shows and describes illustrative embodiments of the invention. Accordingly, the drawings and detailed description are to be regarded as illustrative in nature and not restrictive.

### BRIEF DESCRIPTION OF THE DRAWINGS

[0009] FIG. 1 is a schematic illustration of an integrated perfusion system including a heart lung machine and a data management system in accordance with an embodiment of the invention.

[0010] FIG. 2 is a flow diagram illustrating a method that can be carried out by the integrated perfusion system of FIG. 1.

[0011] FIG. 3 is a flow diagram illustrating a method that can be carried out by the integrated perfusion system of FIG. 1.

[0012] FIG. 4 is a schematic illustration of a heart lung machine pack that may be utilized with the integrated perfusion system of FIG. 1.

[0013] FIG. 5 is a schematic illustration of a perfusion system in accordance with an embodiment of the invention.

[0014] FIG. 6 is an illustration of a blood level sensor that may be utilized with the perfusion system of FIG. 5.

[0015] FIG. 7 is an illustration of a blood level sensor incorporated into a label that may be utilized with the perfusion system of FIG. 5.

[0016] FIG. 8 is an illustration of a blood reservoir including a blood level sensor in accordance with an embodiment of the invention.

[0017] FIG. 9 is an illustration of a hard shell blood reservoir including a blood level sensor in accordance with an embodiment of the invention.

[0018] FIG. 10 is an illustration of a soft shell blood reservoir including a blood level sensor in accordance with an embodiment of the invention.

[0019] FIG. 11 is a flow diagram illustrating a method that can be carried out using the perfusion system of FIG. 5.

[0020] FIG. 12 is an illustration of a blood reservoir including a blood level sensor in accordance with an embodiment of the invention.

[0021] FIG. 13 is an illustration of a blood reservoir including a blood level sensor in accordance with an embodiment of the invention.

[0022] FIG. 14 is a graph illustrating the relationship between VO<sub>2</sub> and DO<sub>2</sub> in an athlete under physical exercise.

[0023] FIG. 15 is a graph illustrating the relationship between VO<sub>2</sub> and DO<sub>2</sub> in a patient under cardiac operation.

[0024] FIG. 16 is a graph illustrating the relationship between VCO<sub>2</sub> and VO<sub>2</sub>.

[0025] FIG. 17 is a graph illustrating the relationship between LAC and VCO<sub>2i</sub>.

[0026] FIG. 18 is a schematic illustration of an embodiment of a perfusion system in accordance with an embodiment of the invention.

[0027] FIG. 19 is a block diagram illustrating a monitoring system in accordance with an embodiment of the invention.

[0028] FIG. 20 is a schematic illustration of a screen capture in accordance with an embodiment of the invention.

[0029] FIG. 21 is a schematic illustration of a screen capture in accordance with an embodiment of the invention.

[0030] FIG. 22 is a schematic illustration of a screen capture in accordance with an embodiment of the invention.

[0031] FIG. 23 is a schematic illustration of a screen capture in accordance with an embodiment of the invention.

#### DETAILED DESCRIPTION

[0032] The disclosure pertains to a perfusion system that is easy to set-up, use and monitor during a bypass procedure. In some embodiments, the disclosure pertains to a perfusion system in which at least some of the disposable components used with the perfusion system are encoded with set-up and/or operational parameters. In some embodiments, the disclosure pertains to a perfusion system in which at least some of the disposable components used with the perfusion system are encoded with identifying information that can unlock additional functionality within the perfusion system.

[0033] In some embodiments, the disclosure pertains to a blood level sensor that can be used to monitor a blood level or volume within a blood reservoir. The blood level sensor may be utilized in an integrated perfusion system in which the disposable components are configured, as noted above, to communicate with the perfusion system. In some embodiments, the blood level sensor may be utilized with a perfusion system lacking communication with disposables.

[0034] FIG. 1 is a schematic illustration of an integrated perfusion system 10. The integrated perfusion system 10 includes a heart lung machine (HLM) 12 and a disposable element 14. In some embodiments, as illustrated, the integrated perfusion system 10 also includes a data management system (DMS) 29. While the HLM 12 and the DMS 29 are illustrated as distinct components, it will be appreciated that in some embodiments, at least some of the functionality of the DMS 29 may be integrated into the HLM 12. In some embodiments, the HLM 12 and the DMS 29 are modular components or systems that can be connected together as desired, or used separately.

[0035] In some instances, at least some of the functionality described with respect to the DMS 29 may instead be incorporated into an inline blood monitor, or ILBM. An ILBM may be connected to the HLM 12 and may measure and/or monitor data directly via a sensor on a blood line. In some embodiments, an ILBM may receive information from the HLM 12 and/or the DMS 29. An ILBM may accept manually inputted

data, and may display data that is manually inputted or received from the HLM 12 or other devices.

[0036] It will be appreciated that while only a single disposable element 14 is shown for ease of illustration, in many embodiments a plurality of different disposable elements 14 may be utilized in combination with the HLM 12. Each of the HLM 12, the disposable element 14 and the DMS 29 will be described in greater detail subsequently. The HLM 12 includes a number of different components. It is to be understood that the particular components illustrated herein as being part of the HLM 12 is merely an example, as the HLM 12 may include other components or different numbers of components.

[0037] In the illustrated embodiment, the HLM 12 includes three pump modules 16, but may include as few as two pump modules 16 or as many as six or seven pump modules 16. In some embodiments, the pump modules 16 may be roller or peristaltic pumps. In some embodiments, one or more of the pump modules 16 may be centrifugal pumps. Each of the pump modules 16 may be used to provide fluid for delivery to or removal from the heart chambers and/or surgical field. In an illustrative but non-limiting example, one pump module 16 draws blood from the heart, another provides surgical suction and a third provides cardioplegia fluid (high potassium solution to arrest the heart). Additional pump modules 16 (not shown) may be added to provide additional fluid transfer.

[0038] Each pump module 16 includes a control unit 18. In some embodiments, each control unit 18 may be configured to operate and monitor the operation of the particular pump module 16 to which it is attached or otherwise connected to. In some embodiments, each control unit 18 may include one or more input devices (not illustrated) such as switches, knobs, buttons, touch screens and the like so that the perfusionist may adjust the operation of the particular pump module 16. Each pump module 16 may include an alphanumeric display that the control unit 18 can use to display, for example, the value of a setting, the value of a current operating parameter, confirmation that the pump module 16 is operating normally, and the like.

[0039] The HLM 12 includes a controller 20 that is in communication with the control units 18 and that is configured to operate the HLM 12. In some embodiments, the controller 20 is configured to monitor one or more sensors that may be distributed on the HLM 12 and/or within the disposable element 14 to monitor operation of the HLM 12. Examples of such sensors (not illustrated for ease of illustration) include but are not limited to flow meters, pressure sensors, temperature sensors, blood gas analyzers and the like.

[0040] While the control units 18 and the controller 20 are illustrated as distinct elements, in some embodiments it is contemplated that these elements may be combined in a single controller. In some embodiments, it is contemplated that the control units 18, in combination, may be configured to operate the HLM 12, thereby negating a need for the controller 20.

[0041] The controller 20 communicates with an input device 22 and an output device 24. The input device 22 may be used by the perfusionist to enter information that is not otherwise entered into the control units 18. The output device 24 may be used by the HLM 12 to display pertinent information to the perfusionist. In some embodiments, the input device 22 may be a key pad, a keyboard, a touch screen, and the like. In some embodiments, the output device 24 may be

a monitor. In some embodiments, either of the input device **22** and/or the output device **24** may be a computer such as a personal computer, a laptop computer, a notebook computer or a tablet computer. In some cases, the input device **22** and the output device **24** may be manifested in a single computer.

**[0042]** In some embodiments, the DMS **29** may be considered as functioning as a flight recorder, recording data from a variety of sources, including the HLM **12** and various external sensors and monitoring devices. In some instances, as illustrated, the DMS may include an RF sensor **26** and a processor **27**. The DMS **29** may communicate with the HLM **12**. In some embodiments, as described herein, the DMS **29** may also provide additional functionality that can be unlocked during use of the HLM **12** and/or the DMS **29**.

**[0043]** The DMS **29** is configured to receive and record data from the HLM **12**. In some embodiments, the DMS **29** may receive and record data from other sources as well, such as external devices. The DMS **29** may include an input device that permits a user to manually enter information. In some embodiments, as discussed herein, the DMS **29** may be configured to operate and display additional functionality. In some embodiments, the DMS **29** may be configured such that at least some of the disposable components **14** used with the integrated perfusion system **10** are encoded with identifying information that can unlock additional functionality within the DMS **29**. A variety of different additional functionality may be unlocked, depending on the identity of the disposable component.

**[0044]** In some embodiments, the DMS **29** may be configured to operate and display a metabolic algorithm. An illustrative but non-limiting example of a suitable metabolic algorithm is known as the Ranucci algorithm. The Ranucci algorithm provides continuous and real-time information regarding the patient's oxygen delivery (DO<sub>2</sub>) and their carbon dioxide production values (VCO<sub>2</sub>), as well as the adequacy of the DO<sub>2</sub> with respect to the patient's metabolic requirements. The Ranucci algorithm is described, for example, in U.S. Pat. Nos. 7,435,200; 7,927,286; and 7,931,601, which are incorporated by reference herein.

**[0045]** The RF sensor **26** may be configured to receive information from an active RFID tag placed on the disposable element **14**, including the aforementioned identity of the disposable component.

**[0046]** In some embodiments, the RF sensor **26** may be a hand held device that is used to scan a passive RFID tag on the disposable element **14**. According to other embodiments, the RF sensor **26** is replaced with any of a variety of known wireless communication receivers. The disposable element **14** includes an RFID tag **28**. According to various embodiments, the disposable element **14** includes either an active RFID tag or a passive RFID tag (or both) configured to communicate with the RF sensor **26**. In other embodiments, the RFID tag **28** is replaced with any of a variety of known wireless communication transmitters.

**[0047]** Passive RFID tags lack a power supply, and instead are powered by an induced current caused by an incoming radio-frequency scan. Because there is no onboard power supply, a passive RFID tag is smaller and less expensive. An active RFID tag includes an onboard power supply such as a battery. While this increases the size and expense of the RFID tag, an advantage is that the RFID tag can store more information and can transmit further. RFID tags, whether active or passive, may be selected to transmit at a variety of frequencies depending on need. Options include low frequency (about

100 to 500 kilohertz), high frequency (about 10 to 15 megahertz), ultra high frequency (about 860 to 960 megahertz) and microwave (about 2.45 gigahertz).

**[0048]** As noted above, the disposable element **14** may be considered as generically representing one, two or a plurality of different disposable elements that may be used in conjunction with the HLM **12**. Illustrative but non-limiting examples of disposable elements **14** include tubing sets, blood reservoirs, oxygenators, heat exchangers and arterial filters. In some embodiments, a tubing set includes a number of different tubes, potentially of different lengths and sizes, for providing fluid flow between components of the HLM **12** as well as providing fluid flow between the HLM **12** and a patient.

**[0049]** In some embodiments, the disposable element **14** may be a blood reservoir such as a venous blood reservoir, a vent blood reservoir, a cardiomy or suction blood reservoir. In some embodiments, the disposable element **14** may be a blood reservoir that combines one or more of a venous blood reservoir, a vent reservoir and/or a suction reservoir in a single structure. In some embodiments, one or more of the aforementioned sensors may be disposable elements that include an RFID tag **28** either to provide information identifying the sensor or even for transmitting sensed values to the controller **20**.

**[0050]** The RFID tag **28** may be attached to the disposable element **14** in any appropriate manner. In some embodiments, the RFID tag **28** may be adhesively secured to the disposable element **14**. In some embodiments, the RFID tag **28** may be molded into the disposable element **14**. In some embodiments, the RFID tag **28** may be a stand alone card, similar in size and shape to a credit card, that may simply be packed with the disposable element **14** in such a way that it can be removed by the user and swiped by the RF sensor **26**. However the RFID tag **28** is attached, the RFID tag **28** may be programmed with or otherwise configured to include a wide variety of information pertaining to the disposable element **14**.

**[0051]** In some embodiments, the RFID tag **28** may include data or identifying information for the disposable element **14**. Illustrative but non-limiting examples of identifying information include the name of the particular disposable element **14**, a reference code, a serial number, a lot number, an expiration date and the like. In some embodiments, this information may be communicated to the controller **20** and may, for example, be used by the controller **20** to confirm that the proper disposable elements **14** are being used for a particular setting, patient or the like. As an example, the controller **20** may recognize that a pediatric tubing set is being used in combination with an adult-sized blood reservoir or other component. As another example, the controller **20** may recognize that an expected component is missing. There are a variety of other potential mismatches in equipment that may be recognized by the controller **20** as a result of the information provided by the RFID tag **28** attached to each of the one or more disposable elements **14**.

**[0052]** In some embodiments, the RFID tag **28** may include descriptive or design information for the disposable element **14**. Illustrative but non-limiting examples of descriptive or design information include specific materials, a list of components, priming volume of a component or tubing circuit, tubing size, tubing length, minimum and maximum working pressures, minimum and maximum working volume, and the like. In some embodiments, this information may be communicated to the controller **20** and may be used by the controller

20 to at least partially configure and/or operate the HLM 12. As an example, the controller 20 may use the sizing information provided from each of the disposable elements 14 to determine a working blood volume for the HLM 12.

[0053] In some embodiments, the information obtained from the RFID tag 28 may also be provided to the perfusionist. In some embodiments, the output device 24 may be configured to provide alphanumeric or graphical representations of the obtained information. In some cases, the RFID tag 28 may include instructional information that may be displayed by the output device 24 in order to instruct the perfusionist in optimal setup and/or operation of a particular disposable element 14. The RFID tag 28 may include warning information that can be transmitted from the RFID tag 28 and displayed on the output device 24. In some embodiments, this warning information may supplement or even replace warning information that might otherwise be included as printed materials packaged with the disposable elements 14.

[0054] In various embodiments, the output device 24 may be a computer such as a personal computer, a laptop computer, a notebook computer or a tablet computer. In some embodiments, the RFID tag 28 may include displayable information that, for example, suggests an optimal circuit design based upon the specific components being used, or perhaps updated use instructions. In some embodiments, information from the RFID tag 28 is displayed on the DMS 29.

[0055] In some embodiments, the RFID tag 28 may include information that a manufacturer of the disposable element 14 wants to provide to the user. Examples of such information may include technical features of the disposable element 14 that have changed from a previous version or even a previous batch. Another example includes information that can be displayed by the output device 24 that require the user to acknowledge receipt of the information before the controller 20 proceeds with a particular procedure. In some cases, the RFID tag 28 may receive error messages from the DMS 29 and/or the controller 20, and the RFID tag 28 may then be returned to the manufacturer, thereby providing the manufacturer with feedback regarding the performance of the disposable element 14 as well as other components.

[0056] In some embodiments, the RFID tag 28 may include information that can be used by an inventory tracking system. In some embodiments, the inventory tracking system may be in communication with the perfusion system 10. In some embodiments, the inventory tracking system may independently and directly receive information from the RFID tag 28 without communicating through the perfusion system 10.

[0057] FIG. 2 is a flow diagram illustrating a method that may be carried out using the perfusion system 10 of FIG. 1. A disposable element 14 having an RFID tag 28 may be attached to the HLM 12, as generally shown at block 30. At block 32, the RFID tag 28 is read. As noted above, the RFID tag 28 may be an active RFID tag or a passive RFID tag. In some embodiments, the RFID tag 28 may be read before the disposable element 14 is attached to the HLM 12. In some embodiments, the RFID tag 28 may be read after attachment. At block 34, the HLM 12 is configured based at least in part upon information that was read from the RFID tag 28 at block 32. In some embodiments, the controller 20 automatically configures the HLM 12 in response to this information. In some embodiments, at least some of the information read from the RFID tag 28 may be captured by the DMS 29.

[0058] FIG. 3 is a flow diagram illustrating a method that may be carried out using the perfusion system 10 of FIG. 1. A disposable element 14 having an RFID tag 28 may be attached to the HLM 12, as generally shown at block 30. At block 32, the RFID tag 28 is read. The RFID tag 28 may be read either before or after the disposable element 14 is attached to the HLM 12. At block 34, the HLM 12 is configured based at least in part upon information that was read from the RFID tag 28 at block 32. In some embodiments, the controller 20 automatically configures the HLM 12 in response to this information. At least some of the information read from the RFID tag 28 may be displayed on the output device 24, as seen at block 36, or on the DMS 29.

[0059] FIG. 4 is a schematic illustration of a heart lung machine pack 38 that may be utilized with the perfusion system 10 of FIG. 1. In some embodiments, the heart lung machine pack 38 may include all of the disposable elements 14 that will be used together for a particular patient and may be customized for the particular patient. In some embodiments, the heart lung machine pack 38 may include a housing 40 that, once filled, can be sealed up to keep the contents clean and sterile

[0060] In the illustrated embodiment, the heart lung machine pack 38 includes a tubing set 42 and a disposable component 44. The tubing set 42 may include a plurality of different tubes. The disposable component 44 may be any of the disposable components discussed above with respect to the disposable element 14. In some embodiments, the heart lung machine pack 38 will include a plurality of different disposable components 44. The tubing set 42 includes a first RFID tag 46 while the disposable component 44 includes a second RFID tag 48. As discussed above, each of the first RFID tag 46 and the second RFID tag 48 may be either active or passive RFID tags and may include readable information pertaining to the component to which they are attached. In some instances, the housing 40 may include a third RFID tag 50 that, for example, identifies the contents of the heart lung machine pack 38. In some embodiments, the first RFID tag 46 and the second RFID tag 48 may not be included, as the third RFID tag 50 may be encoded with all of the information for the tubing set 42 and the disposable component 44.

[0061] FIG. 5 is a schematic illustration of a perfusion system 52. The perfusion system 52 includes an HLM 54 that in some embodiments may be similar in structure and operation to the HLM 12 discussed with respect to FIG. 1. The perfusion system 52 also includes a blood reservoir 56, a blood level sensor 58 and a controller 60. The blood reservoir 56 may be a venous blood reservoir, a vent blood reservoir, a cardiotomy or suction blood reservoir. In some embodiments, the blood reservoir 56 may be a blood reservoir that combines one or more of a venous blood reservoir, a vent reservoir and/or a suction reservoir in a single structure.

[0062] The blood level sensor 58 may be configured to continuously monitor a variable blood level within the blood reservoir 56. The blood level sensor may be chosen from a variety of different sensing technologies. In some embodiments, as will be discussed subsequently with respect to FIGS. 12 and 13, the blood level sensor 58 may be an ultrasonic sensor in which ultrasound is used to detect the blood level within the blood reservoir 56. In some embodiments, the blood level sensor 58 may be an optical sensor in which a laser beam or light from an infrared light source is reflected by the liquid-air interface and the reflected light beam is detected by the blood level sensor 58. According to exemplary embodi-

ments, the blood level sensor **58** is an optical distance sensor of the type commercially sold by Leuze electronic GmbH located in Owen/Teck, Germany (e.g., ODSL8, ODSL 30, or ODS 96). In some embodiments, the blood level sensor **58** may be a load cell or scale that is configured to measure a mass of the blood reservoir **56** and thereby determine the volume of blood therein.

[0063] In some embodiments, the blood level sensor **58** may be a capacitive sensor (better illustrated in subsequent Figures) that outputs an electrical signal that is proportional to or otherwise related to a blood level within the blood reservoir **56**. The electrical signal may be communicated in either a wired or wireless fashion to the controller **60**. While the controller **60** is shown as a distinct element, in some embodiments the controller **60** is manifested as part of a controller (similar to the controller **20**) operating the HLM **54**.

[0064] In some embodiments, the blood level sensor **58** may be modeled after capacitive sensors (e.g., CLC or CLW series) available commercially from Sentechnics GmbH located in Puchheim, Germany, which are configured to provide contact-free measurement of continuous liquid level. The sensor available from Sentechnics may be disposed on an outer surface of a container and provides an electrical signal representative of the liquid level within the container. In some instances, the Sentechnics sensor may be spaced as much as about five millimeters from the liquid within the sensor, with no more than about twenty percent air gap between the sensor and the liquid. According to various embodiments, the capacitive sensor **58** is molded inside the blood reservoir **56**, such that only the connector is accessible outside the reservoir. In these embodiments, the sensor **58** is protected by the plastic material of the blood reservoir.

[0065] In some embodiments, the sensor may undergo an initial configuration to adapt the sensor to the particulars of the container itself as well as the liquid within the container. In some embodiments, the blood level sensor **58** has a five pin electrical connection, including a voltage source, an analog signal out, a digital signal out, a teach-in pin and a ground. In some embodiments, the level sensor **58** is a capacitive sensor such as the Balluff SmartLevel sensor commercially sold by Balluff GmbH located in Neuhausen, Germany.

[0066] The controller **60** may receive an electrical signal that is proportional to or at least related to a blood level within the blood reservoir **56**. The controller **60** may calculate a blood volume based on this electrical signal as well as a known shape or geometry of the blood reservoir **56**. In some embodiments, the blood reservoir **56** may include an RFID tag (not illustrated) that provides the controller **60** with information pertaining to the known geometry of the blood reservoir **56**.

[0067] If the blood reservoir **56** is a hard shell blood reservoir, the known geometry of the blood reservoir **56** may include the cross-sectional area of the blood reservoir **56**, or a width and depth of the blood reservoir **56** as well as details on how this cross-sectional area varies relative to height within the blood reservoir **56**. If the blood reservoir **56** is a soft shell reservoir, the known geometry may be based at least in part upon a known lateral expansion rate of the soft shell reservoir relative to the blood level within the blood reservoir **56**.

[0068] As can be seen in FIG. 6, the blood level sensor **58** includes a first elongate electrode **60** and a second elongate electrode **62**. The first elongate electrode **60** and the second elongate electrode **62** are disposed along a flexible substrate

**64**. In some embodiments, the flexible substrate **64** may include an adhesive layer that can be used to secure the blood level sensor **58** to the blood reservoir **56**. A connector socket **66** is secured to the flexible substrate **64** and is electrically connected to the first elongate electrode **60** and the second elongate electrode **62** in order to permit an electrical connection between the first and second electrodes **60**, **62** and an electrical cable (not illustrated in this Figure). In some embodiments, rather than an elongate sensor, the blood level sensor **58** may include two or more distinct SMART-LEVEL™ capacitive sensors such as those available commercially from Balluff. These sensors may provide a binary, yes/no signal. By locating several of these sensors at differing levels proximate the blood reservoir **56**, the blood level within the blood reservoir **56** may be determined.

[0069] In some embodiments, the blood level sensor **58** may be attached to or otherwise integrated into a label **68** as seen in FIG. 7. The label **68** may include various indicia **70** such as use instructions, volume indicators and the like. In some embodiments, the label **68** may include an adhesive side for attachment to an outer surface of the blood reservoir **56**. In some embodiments, the label **68** is oriented on the blood reservoir such that a lower portion of the blood level sensor **58** is aligned at or near a bottom of the blood reservoir **56**.

[0070] In some embodiments, the blood level sensor may be an ultrasonic blood level sensor, as illustrated in FIGS. 12 and 13. FIG. 12 is an illustration of a blood reservoir **82** that contains a volume of blood. The volume of blood defines an interface **84** between the volume of blood and the air or other fluid within the blood reservoir **82**. In some embodiments, an ultrasonic transducer **86** that is located at or near a lower surface of the blood reservoir **82** can be used to locate the interface **84** by transmitting ultrasonic waves **88** towards the interface **84**. The reflectance of the ultrasonic waves **88** depend at least in part upon the fluid they are passing through. Thus, by measuring the reflectance, the ultrasonic transducer **86** can determine how far away the interface **84** is and thereby determine the fluid level. Based on the fluid level and the geometric configuration of the blood reservoir **82**, a controller may determine the blood volume within the blood reservoir **82**. In some embodiments, a cable **90** transmits a signal from the ultrasonic transducer **86** to the controller. In some embodiments, the information is transmitted wirelessly, such as via an RFID tag attached to the ultrasonic transducer.

[0071] FIG. 13 is similar to FIG. 12, but shows a blood reservoir **92** having a blood volume defining an interface **94**. In this embodiment, an ultrasonic transducer **96** is located at or near a top of the blood reservoir **92** and transmits ultrasonic waves **98** downward towards the interface **94**. In some embodiments, a cable **100** transmits a signal from the ultrasonic transducer **96** while in other embodiments this is done wirelessly, such as with an RFID tag attached to the ultrasonic transducer **96**. A primary difference between the embodiments shown in FIGS. 12 and 13 is that in FIG. 12, the interface **84** is detected from below, or through the blood, while in FIG. 13 the interface **94** is detected from above, or through the air.

[0072] In some embodiments, the blood level sensor may be an infrared (IR) light blood level sensor. In some embodiments, an infrared light source positioned at or near a lower surface of the blood reservoir **82** may be used to locate a fluid/air interface within the blood reservoir **82** by transmitting infrared light towards the interface. Alternatively, the infrared light blood level sensor may be located above the



interface. In some embodiments, the infrared light blood level sensor may be located a short distance away from the blood reservoir **82** and thus can be attached to a mechanical holder for the blood level reservoir **82**.

**[0073]** In some instances, the infrared light is reflected back towards the infrared light blood level sensor. By measuring the reflectance, the location of the interface may be determined. In some embodiments, the infrared light travels through the blood to an infrared light sensor located opposite the infrared light blood level sensor. By detecting changes in the received light, the interface location may be determined. By combining the interface location with known geometric parameters of the blood reservoir **82**, the controller **20** can determine the blood volume within the blood reservoir **82**. In some embodiments, this information is transmitted wirelessly to the controller **20**, such as via an RFID tag attached to the infrared light blood level sensor.

**[0074]** FIG. **8** is an illustration of the blood level sensor **58** attached to the blood reservoir **56**. An electrical cable **72** provides an electrical connection between the blood level sensor **58** and the controller **60**. The electrical cable **72** includes a plug **73** that is configured to connect to the electrical connector **66**. In some embodiments, the plug **73** includes circuitry that converts a detected capacitance into a voltage signal that the controller **60** can use to calculate the blood volume. In some embodiments, the plug **73** further includes circuitry to calculate the blood volume.

**[0075]** As noted above, the blood reservoir **56** may be either a hard shell reservoir or a soft shell reservoir. FIG. **9** illustrates a hard shell reservoir **74** bearing the blood level sensor **58** while FIG. **10** illustrates a soft shell reservoir **76** including the blood level sensor **58**. In either case, the reservoir may be constructed to include the blood level sensor **58**. In some embodiments, the blood level sensor **58** may be adhesively secured to an existing blood reservoir.

**[0076]** FIG. **11** is a flow diagram illustrating a method that may be carried out using the perfusion system **52** of FIG. **5**. A capacitance between first and second electrodes may be detected, as referenced at block **78**. In some embodiments, as discussed above, the capacitance may be converted into an electrical signal representing the blood level by circuitry within the plug **73**. In embodiments using the CLC series Sensortech sensor, for example, the sensor will output a voltage between 0.5 and 4.5 volts. Assuming the sensor pad is appropriately located on the reservoir, this voltage indicates a level or height of the liquid in the reservoir. At block **80**, the controller **60** may calculate a blood volume that is based upon the detected capacitance and a known dimensions or geometry of the blood reservoir **56**. In some embodiments, the controller **60** (or other circuitry within the HLM **54**) may provide the circuitry in the plug **73** with sufficient information (e.g., dimensions or geometry) regarding the blood reservoir **56** to permit the circuitry to perform the blood volume calculation. In some embodiments, the calculated blood volume is communicated to the HLM **54** so that it may adjust an operating parameter of the HLM **54**. In various exemplary embodiments, the HLM **54** may alter a pump speed to either increase or decrease blood flow into or out of the blood reservoir **56**. It may be important, for example, to prevent the blood level in the reservoir **56** from moving below a certain minimum level or volume. Accordingly, in various embodiments, the HLM **54** will compare the blood level or volume to this minimum level and adjust pump speed appropriately.

**[0077]** According to other embodiments, the HLM **54** may use the blood volume information for a variety of applications, including for example auto-regulation of pump occlusion, auto-loading of pump segments, conducting automatic occlusivity testing, performing automatic priming, automatic recirculating and debubbling, conducting automatic pressure tests, or performing automatic system emptying.

**[0078]** In some embodiments, and as noted above, the perfusion system **10** may be configured such that at least some of the disposable components used with the perfusion system **10** are encoded with identifying information that can unlock additional functionality within the perfusion system. A variety of different additional functionality may be unlocked, depending on the identity of the disposable component.

**[0079]** In some embodiments, for example, if the disposable component is or otherwise includes a tubing set (such as the tubing set **42** shown in FIG. **4**), the tubing set may include an RFID tag (such as the 1<sup>st</sup> RFID **46** shown in FIG. **4**) that is programmed or otherwise includes information that can be used by the perfusion system **10** to determine the priming volume of a blood circulation system. The blood circulation system may include only items included in the tubing set, or the blood circulation system may include additional items.

**[0080]** The presence of the tubing set may enable the DMS **29** to operate and display a priming volume simulator. In some embodiments, for example if a different tubing set is used, or perhaps a tubing set from a different manufacturer, the priming volume simulator may be disabled or otherwise not permitted to function. Hence, the presence of the particular tubing set (or other disposable component) may unlock the additional functionality of a priming volume simulator.

**[0081]** In some embodiments, the DMS **29** may be configured to operate and display an algorithm that monitors and/or provides data related to a patient's metabolism. In some embodiments, the algorithm may be unlocked by the DMS **29**, depending on the identity of the disposable component **14**. While a variety of different algorithms are known and may be unlocked by the DMS **29**, an illustrative but non-limiting example of an algorithm that can be programmed into the perfusion system **10** and that may be unlocked if appropriate disposable components **14** are used includes a priming volume simulator. Another example is a metabolic algorithm is known as the Ranucci algorithm, referenced above.

**[0082]** In understanding and describing the Ranucci algorithm, certain definitions are useful.

**[0083]** HCT: hematocrit N.

**[0084]** Hb: hemoglobin (g/dL).

**[0085]** CPB: cardiopulmonary bypass.

**[0086]** T: temperature (° C.).

**[0087]** VO<sub>2</sub>=oxygen consumption (mL/min).

**[0088]** VO<sub>2i</sub>=oxygen consumption indexed (mL/min/m<sup>2</sup>).

**[0089]** DO<sub>2</sub>=oxygen delivery (mL/min).

**[0090]** DO<sub>2i</sub>=oxygen delivery indexed (mL/min/m<sup>2</sup>).

**[0091]** O<sub>2</sub> ER=oxygen extraction rate N.

**[0092]** VCO<sub>2</sub>=carbon dioxide production (mL/min).

**[0093]** VCO<sub>2i</sub>=carbon dioxide production indexed (mL/min/m<sup>2</sup>).

**[0094]** V<sub>e</sub>=ventilation (L/min).

**[0095]** eCO<sub>2</sub>=exhaled carbon dioxide (mmHg).

**[0096]** AT=anaerobic threshold.

**[0097]** LAC=lactates.

**[0098]** Q<sub>c</sub>=cardiac output (mL/min).

**[0099]** IC=cardiac index (Q<sub>c</sub>/m<sup>2</sup>), (mL/min/m<sup>2</sup>).

**[0100]** Q<sub>p</sub>=pump flow (mL/min).

[0101]  $IP$ =pump flow indexed ( $Qp/m^2$ ), ( $mL/min/m^2$ ).

[0102]  $CaO_2$ =arterial oxygen content ( $mL/dL$ ).

[0103]  $CvO_2$ =venous oxygen content ( $mL/dL$ ).

[0104]  $PaO_2$ =arterial oxygen tension ( $mmHg$ ).

[0105]  $PvO_2$ =venous oxygen tension ( $mmHg$ ).

[0106]  $a$ =arterial.

[0107]  $v$ =venous.

[0108]  $Sat$ =Hb saturation (%).

[0109] The following equations are useful in the Ranucci algorithm.

$$VO_2 = Qc \times (CaO_2 - CvO_2) \text{ in a normal circulation} \quad (1)$$

$$VO_2 = Qp \times (CaO_2 - CvO_2) \text{ during CPB} \quad (2)$$

$$DO_2 = Qc \times CaO_2 \text{ in a normal circulation} \quad (3)$$

$$DO_2 = Qp \times CaO_2 \text{ during CPB} \quad (4)$$

$$O_2ER = VO_2 / DO_2 (\%) \quad (5)$$

$$Hb = HCT / 3 \quad (6)$$

$$CaO_2 = Hb \times 1.36 \times Sat(a) + PaO_2 \times 0.003 \quad (7)$$

$$CvO_2 = Hb \times 1.36 \times Sat(v) + PvO_2 \times 0.003 \quad (8)$$

$$VCO_2 = V_{ex} \times CO_2 \times 1.15 \quad (9)$$

[0110] The oxygen consumption ( $VO_2$ ) is the sum of the metabolic needs of each specific organ and thus represents the metabolic needs of the whole organism. Under basal conditions (at rest), it is about 3-4  $mL/min/kg$ , i.e. about 250  $mL/min$  for a subject weighting 70 kgs. Applying equations (3) and (7), the oxygen delivery ( $DO_2$ ) may be calculated, and is about 1000  $mL/min$ . Therefore, a considerable functional reserve exists, since the  $DO_2$  is about 4 times greater than the  $VO_2$ . The  $VO_2$  may increase depending on the metabolic needs (basically under physical exercise, but even in pathologic conditions like septic shock). A top level endurance athlete may reach a maximal  $VO_2$  of about 5000  $mL/min$ .

[0111] Of course, to meet these increasing oxygen demands, the  $DO_2$  must increase as well: it can reach, in an athlete during exercise, the value of 6000  $mL/min$  ( $Qc$ : 30  $L/min$  with an unchanged arterial oxygen content of 20  $mL/dL$ ). As a consequence, the  $O_2$  ER may increase up to 75%.

[0112] FIG. 14 is a diagram showing the relationship between  $DO_2$  and  $VO_2$  in an athlete during physical exercise. If the athlete (that, for example, is running a marathon) falls into the dark triangular zone (where the  $DO_2$  is unable to support the  $VO_2$ ), the athlete is forced to use other metabolic mechanisms in order to develop mechanical energy. In particular, the athlete will undergo anaerobic lactic acid metabolism, which develops energy but at the expenses of lactic acid formation, local and systemic acidosis, and finally exercise stops usually within 2 minutes. In other words, the  $VO_2$  is physiologically dependent on the  $DO_2$ .

[0113] In the medical field, of course, the situation is different. The  $DO_2$  may pathologically decrease in case of: decreased arterial oxygen content due to anemia; decreased arterial oxygen content due to hypoxia; and decreased cardiac output. However, due to the existence of the above-mentioned physiological reserve, the  $VO_2$  may be maintained even for a  $DO_2$  decrease down to about 600  $mL/min$  ( $DO_2i$  320  $mL/min/m^2$ ), due to the increased  $O_2$  ER.

[0114] FIG. 15 is a diagram showing the relationship between  $DO_2$  and  $VO_2$  in the range observed during medical conditions (i.e. cardiac operation). Below a  $DO_2$  of 600  $mL/min$ ,  $VO_2$  starts decreasing. The patient meets, exactly as the athlete, a lactic acidosis, with lactate (LAC) production. In other words, the patient experiences a shock. The  $DO_2$  level below which the  $VO_2$  starts decreasing and becomes pathologically dependent on the  $DO_2$  is called the critical  $DO_2$  ( $DO_{2crit}$ ). Maintaining the  $DO_2$  above this threshold is very important in many pathological conditions, to avoid an acidosis-shock status. The  $DO_{2crit}$  is higher during a septic shock.

[0115] Since 1994, in a paper published in *Perfusion*, Ranucci and coworkers demonstrated that in a series of 300 consecutive patients that underwent myocardial revascularization with CPB, the presence of a severe hemodilution was an independent risk factor for a postoperative acute renal failure (ARF). In particular, the cut-off value was identified at an  $HCT < 25\%$ .

[0116] Subsequently, other authors have demonstrated that the lowest HCT during CPB was an independent risk factor for many "adverse outcomes" in cardiac surgery. Stafford-Smith and coworkers, in 1998 (*Anesth Analg*), confirmed the relationship between hemodilution and ARF.

[0117] More recently, the lowest hematocrit on CPB has been recognized as an independent risk factor for postoperative low cardiac output and hospital mortality by Fang and coworkers (*Circulation*, 1997), and for an impressive series of postoperative adverse events by Habib and coworkers in 2003 (*J Thorac Cardiovasc Surg*). The relationship between hemodilution and ARF has been subsequently confirmed by Swaminathan and coworkers in 2003 (*Ann Thorac Surg*), Ranucci and coworkers 2004 and 2005 (*Ann Thorac Surg*) and Karkouti and coworkers in 2005 (*J Thorac Cardiovasc Surg*). The critical HCT value below which the ARF risk significantly increases is located between 23% and 26%.

[0118] Almost all the authors ascribe this relationship to an insufficient oxygen supply ( $DO_2$ ) to the various organs. The kidney, in particular, due to its physiologic condition of hypoxic perfusion, seems to be at high risk.

[0119] Surprisingly, all the studies demonstrating a relationship between HCT and ARF or other organ damages failed to consider that the HCT is only one of the two determinants of the  $DO_2$  during CPB: the other is the pump flow ( $Qp$ ). This would not influence the  $DO_2$  if the  $Qp$  was a constant, but this is not the case. In all the studies, the pump flow ( $Qp$ ) varied from a  $Qpi$  of 2.0  $L/min/m^2$  to a  $Qpi$  of 3.0  $L/min/m^2$ , and the variation was dependent on the perfusion pressure. An HCT of 24% results in a  $DO_2i$  of 230  $mL/min/m^2$  if the  $Qpi$  is 2.0  $L/min/m^2$ , and of 344  $mL/min/m^2$  if the  $Qpi$  is 3.0  $L/min/m^2$ .

[0120] In a scientific paper in *The Annals of Thoracic Surgery*, Ranucci and coworkers actually demonstrated that the  $DO_2i$ , rather than the HCT, is the best predictor of ARF. Moreover, in presence of perioperative blood transfusions, the  $DO_2i$  remains the only determinant of ARF. The  $DO_{2crit}$  identified in this paper is 272  $mL/min/m^2$ , very close to the one previously defined as the  $DO_2i$  below which the  $VO_2$  becomes pathologically dependent on the  $DO_2$ . In other words, maintaining the  $DO_2i$  above this threshold allows a decrease in the hypoxic organ dysfunction or the elimination of the hypoxic organ dysfunction; in presence of a low HCT, an adequate increase of the  $Qp$  may minimize the deleterious effects of hypoxemia. As a consequence, a continuous moni-

toring of the DO<sub>2</sub> is of paramount importance in order to limit the postoperative complications, namely the renal ones.

**[0121]** Measuring a low HCT has poor clinical value, since the only possible (and arguable) countermeasure is a blood transfusion. On the other hand, the DO<sub>2</sub> may be modulated by increasing the pump flow.

**[0122]** The level of DO<sub>2,crit</sub>, below which the LAC production begins, is identified by the concept of “anaerobic threshold” (AT). In athletes, it is the level of expressed mechanical power at which the LAC production begins; in a patient, it is the level of DO<sub>2,crit</sub>, below which the LAC production begins.

**[0123]** It has been demonstrated that the LAC value during CPB is predictive for postoperative complications. The problem is that the LAC value is not available on-line, and only some devices (blood gas analyzers) provide it. It is however possible to make an “indirect” assessment of the AT. As a matter of fact, under steady conditions, the VO<sub>2</sub>/VCO<sub>2</sub> ratio is a constant, while during anaerobic lactic acid metabolism the VCO<sub>2</sub> increases more than the VO<sub>2</sub>. This happens because the lactic acid undergoes the following transformation:  $H\text{LAC} + \text{NaHCO}_3 = \text{LACNa} + \text{H}_2\text{CO}_3$ , and the  $\text{H}_2\text{CO}_3$  is split into  $\text{H}_2\text{O}$  and  $\text{CO}_2$ , with a further  $\text{CO}_2$  production.

**[0124]** FIG. 16 is a diagram showing the relationship between VO<sub>2</sub> and VCO<sub>2</sub>. The relationship between VCO<sub>2</sub> and LAC production has been demonstrated in 15 consecutive patients under CPB, in an experimental trial performed by the inventor himself. In FIG. 17, the graphical relationship between VCO<sub>2</sub> and LAC production is reported. From this relationship, it appears that a VCO<sub>2</sub> value of 60 ml/min/m<sup>2</sup> is a sensitive predictor of lactic acidosis.

**[0125]** Under normal resting conditions, oxygen delivery matches the overall metabolic demands of the organs and the oxygen consumption (VO<sub>2</sub>) is about 25% of the oxygen delivery (DO<sub>2</sub>), and energy is produced basically through the aerobic mechanism (oxidative phosphorylation). When the DO<sub>2</sub> starts decreasing (due to a decreased cardiac output, extreme hemodilution, or both), the VO<sub>2</sub> is maintained until a “critical level” is reached. Below this critical point the oxygen consumption starts decreasing, becoming dependent on the oxygen delivery, and the failing aerobic energy production is progressively replaced by anaerobic adenosine triphosphate production (pyruvate conversion to lactate).

**[0126]** As a result, blood lactate concentration starts rising, and numerous studies have established the use of lactates as a marker of global tissue hypoxia in circulatory shock. Under these circumstances, the anaerobic metabolism results in an excess of proton production and tissue acidosis; buffering of the protons by bicarbonate ions results, in turn, in an anaerobic carbon dioxide production (VCO<sub>2</sub>). Therefore, below the critical DO<sub>2</sub>, there is a linear decrease of both VO<sub>2</sub> and VCO<sub>2</sub>, but due to the anaerobic CO<sub>2</sub> production, the respiratory quotient (VCO<sub>2</sub>/VO<sub>2</sub>) RQ increases. When the critical DO<sub>2</sub> is reached due to a decrease in cardiac output (cardiogenic shock), the above relationship becomes more complex.

**[0127]** Due to the reduced pulmonary flow and to ventilation-perfusion mismatch, the ability of the lung to eliminate carbon dioxide is impaired, and carbon dioxide elimination and end-tidal carbon dioxide tension are decreased. Consequently, carbon dioxide starts accumulating in the venous compartment, and the venoarterial carbon dioxide gradient is increased. In other terms, the VCO<sub>2</sub> (intended as carbon dioxide production by the tissues) becomes progressively higher than carbon dioxide elimination.

**[0128]** Under CPB conditions, the above pattern changes again. The artificial lung is much more efficient than the natural lung in terms of carbon dioxide clearance, and is maintained even for a very low pump flow. Not by chance, under specific circumstances like deep hypothermia and according to the pH strategy, it is clinically needed to add carbon dioxide to the gas flow in order to avoid dramatic and dangerous patterns of hypocapnia. In this setting, the VCO<sub>2</sub> is strictly correlated to the carbon dioxide elimination.

**[0129]** Therefore, while in a normal setting the venous carbon dioxide tension (PvCO<sub>2</sub>) is inverse to the carbon dioxide elimination, during CPB the two parameters are positively correlated. Subsequently, Ranucci and coworkers found that the best predictor of hyperlactatemia during CPB was the DO<sub>2</sub>/VCO<sub>2</sub> ratio, with a cut off value around 5.0, and the VCO<sub>2</sub>, with a cut off value at 60 ml/min/m<sup>2</sup>.

**[0130]** In some embodiments, it is believed that low values of DO<sub>2</sub> during CPB may create an ischemic environment to the kidney. Extremely low values of DO<sub>2</sub> may trigger anaerobic metabolism with lactate production. This may be detected using CO<sub>2</sub>-derived parameters

**[0131]** In some embodiments, therefore, the integrated perfusion system 14 may include one or more of a pump flow reading device and a hematocrit value reading device. The integrated perfusion 10 system includes an input device 22 and a controller 20 that is programmed or otherwise configured to compute the oxygen delivery (DO<sub>2i</sub>) value on the basis of the measured pump flow (Q<sub>p</sub>), the measured hematocrit (HCT), the preset value of arterial oxygen saturation (Sat(a)), and the preset value of arterial oxygen tension (PaO<sub>2</sub>) and a display.

**[0132]** In some embodiments, the perfusion system 14 also includes a CO<sub>2</sub> reading device for continuously detecting exhaled CO<sub>2</sub> (eCO<sub>2</sub>) at the oxygenator gas escape of the HLM. The input device 22 allows the operator to insert a gas flow value (V<sub>e</sub>) and the controller 20 computes the CO<sub>2</sub> production (VCO<sub>2i</sub>) on the basis of the preset gas flow (V<sub>e</sub>) value and the detected exhaled CO<sub>2</sub> (eCO<sub>2</sub>), and the output device 24 shows the calculated value of CO<sub>2</sub> production (VCO<sub>2i</sub>).

**[0133]** In some embodiments, the controller 20 is programmed or otherwise configured to compare the above mentioned oxygen delivery (DO<sub>2i</sub>) value with a threshold value of oxygen delivery (DO<sub>2i,crit</sub>) and to trigger an alarm when the oxygen delivery (DO<sub>2i</sub>) value falls below the threshold value of oxygen delivery (DO<sub>2i,crit</sub>). In one embodiment, the threshold value of oxygen delivery (DO<sub>2i,crit</sub>) is preset by the operator at a value of about 270 ml/min/m<sup>2</sup>.

**[0134]** In some embodiments, the perfusion system 10 further includes a temperature detecting device configured to continuously measure a body temperature (T) of the patient and to send the temperature values to the controller 20, to be subsequently displayed by the output device 24. The controller 20 may be programmed or otherwise configured to calculate, based on the temperature (T) of the patient, an oxygen delivery threshold. In some embodiments, the controller 20 is programmed or otherwise configured to calculate the hemoglobin (Hb) value from the detected hematocrit (HCT) value.

**[0135]** FIG. 18 shows a patient 101 laying on a surgical table 102. An embodiment of a HLM 103, is connected to the patient 101. A HLM 103 includes a venous extracorporeal circuit, collecting blood from the venous system of the patient. A roller or centrifugal mechanical pump 104 pumps the venous blood from a venous extracorporeal circuit

towards an oxygenator **105**, whose role is removing CO<sub>2</sub> from the venous blood and supplying oxygen (O<sub>2</sub>). The blood oxygenated by the oxygenator **105**, is sent, again by the same roller or centrifugal pump **104**, to an arterial extracorporeal circuit connected to the arterial system of the patient, therefore creating a total bypass of the heart and lungs of the patient.

[0136] The monitoring system **110**, is operatively connected to the heart-lung machine **103** and may include a processor that is able to perform calculations, as subsequently explained, and a monitor screen or display **111** that provides an interface with the operator. Using a knob **50** (seen in FIGS. **20** and **21**), an operator may manually input data.

[0137] Examples of data that may be manually inputted include, but are not limited to, the height and weight of the patient and the arterial oxygen saturation (Sat(a)). While this value is usually 100 percent, in some situations such as oxygenator malfunction, the value may decrease. In some embodiments, the arterial oxygen saturation value may be continuously or discretely (every twenty minutes or so) monitored by an external device that may be connected to the DMS **29**. In some embodiments, if the Sat(a) value is not monitored, the DMS **29** may be programmed to assume that it is 100%.

[0138] The arterial oxygen tension value (PaO<sub>2</sub>) may also be manually entered. The PaO<sub>2</sub> value is measured by the perfusionist on the arterial blood of the patient with blood gas analysis, using an adequate and specific device. In some embodiments, the arterial oxygen tension value may be continuously or discretely (every twenty minutes or so) monitored by an external device connected to the DMS **29**.

[0139] The gas flow value (V<sub>e</sub>) may be manually entered. The V<sub>e</sub> value is established by the perfusionist operating the heart-lung machine **103**. Generally, the V<sub>e</sub> is regulated with a flow-meter, according to the patient's parameters. This V<sub>e</sub> value rarely changes during a CPB procedure, and therefore can be manually inserted by the operator. However, as an alternative, the monitoring system **110** may include an electronic flow-meter connected to the heart-lung machine **103**, to continuously detect the V<sub>e</sub> value.

[0140] In some embodiments, the DMS **29** may be configured to calculate and display the oxygen consumption rate (VO<sub>2</sub>) and/or the carbon dioxide production (VCO<sub>2</sub>). As noted above, the VO<sub>2</sub> value may be calculated using equation 2 and the VCO<sub>2</sub> value may be calculated using equation 9:

$$VO_2 = Q_p \times (CaO_2 - CvO_2) \text{ during CPB} \quad (2)$$

$$VCO_2 = V_e \times eCO_2 \times 1.15 \quad (9)$$

[0141] In some embodiments, the V<sub>e</sub> value (gas flow) may be automatically and continuously acquired from a gas blender that is connected to the HLM **12**. In some instances, the V<sub>e</sub> value may be manually entered into the DMS **29**. In some embodiments, the expired CO<sub>2</sub> value (eCO<sub>2</sub>) may be continuously or discretely (about every twenty minutes or so) monitored by an external device connected to the HLM **12**. The eCO<sub>2</sub> value may be separately monitored and manually entered into the DMS **29**.

[0142] In some embodiments, the monitoring device **110** is electrically connected to the HLM **103**, so as to continuously receive data collected by adequate sensors placed in specific positions of the heart-lung machine. Illustrative but non-limiting examples of continuously collected data include the patient's body temperature (T). The temperature T may be continuously measured by a temperature probe **140** inserted inside the esophagus or the rectum or other organs of the

patient. The temperature probe **140** sends an electronic signal of the temperature to a monitor of the HLM **103** visualizing, in real-time, the temperature value. In this case, it is sufficient to interface with an electrical connection the monitor of the HLM **103** with the monitoring device **110**, for a continuous input of the temperature value T.

[0143] Another monitored value includes the exhaled carbon dioxide (eCO<sub>2</sub>). The eCO<sub>2</sub> value is continuously measured through a CO<sub>2</sub> detector **141** placed at the gas escape of the oxygenator **105** to detect the sidestream CO<sub>2</sub> exhaled from the oxygenator **105**. The CO<sub>2</sub> detector **141** can be any kind of CO<sub>2</sub> detector among the various commercially available and re-usable capnographs.

[0144] Another monitored value includes the hematocrit (HCT). The HCT value is continuously measured through a hematocrit reading cell **142** placed inside the arterial or venous circuit of the HLM **103**. In some embodiments, the HCT value may be discretely measured, for example, about every twenty minutes or so by an external device that may be connected to the DMS **29**. In some embodiments, the HCT value may be independently monitored and manually inputted into the controller **20** and/or the DMS **29**. For instance, in FIG. **18**, the hematocrit reading cell **142** is placed inside the arterial line between the pump **104** and the oxygenator **105**. The hematocrit reading cell **142** is commercially available and disposable.

[0145] Another monitored value includes the pump flow rate (Q<sub>p</sub>). The Q<sub>p</sub> value is continuously measured through the Doppler reading cell **143**, placed on the arterial line of the HLM **103**. This kind of Doppler reading cell **143** measures the blood flow on the basis of the Doppler principle (red cells velocity).

[0146] In some embodiments, if the pump **104** is a centrifugal pump, it is already equipped with a Doppler reading cell **143**. Conversely, if the pump **104** is a roller pump, the Doppler reading cell **143** may be added. In the alternative, the Doppler reading cell **143** may be omitted, since the roller pump head is provided with a flow measuring system. In this case, the data regarding the pump flow Q<sub>p</sub> is directly sent to the monitoring device **110**.

[0147] With specific reference to FIG. **19**, operation of the monitoring system **110** is described below. The processor of the monitoring system **110** includes a first computing program **112** that, based on the weight and height of the patient as input by the operator calculates, according to pre-defined tables, the body surface area (BSA) of the patient.

[0148] The BSA value is sent to a second computing program **113** that receives the input value of the pump flow Q<sub>p</sub> as detected by the pump **104** of the HLM **103**. The second computing program **113** calculates the indexed pump flow Q<sub>pi</sub>, according to the relationship Q<sub>pi</sub> = Q<sub>p</sub>/BSA.

[0149] A third computing program **114** receives the input value HCT as detected by the hematocrit reading cell **143** placed inside the venous or arterial line of the heart-lung machine. The third computing program **114**, based on the equation (6), calculates the hemoglobin value Hb. The Hb value is sent to the display **111** and is displayed in a window **151** of the display **111** (FIG. **20**).

[0150] The pump flow indexed Q<sub>pi</sub> computed by the second computing program **113** and the hemoglobin value Hb computed by the third computing program **114** are sent to a fourth computing program **115** that receives as input values the values of arterial oxygen saturation (Sat(a)) and arterial oxygen tension (PaO<sub>2</sub>) manually entered by the operator. The

fourth computing program 115, according to the equation (4), calculates the indexed oxygen delivery value (DO2i).

[0151] As shown in FIG. 20, the DO2i value is visualized in real time in a window 153 of the display 111 and as a graphical pattern 152 (as a function of time). The display 111 is provided with a chronometer window 156 showing the time passed from the beginning of the CPB.

[0152] As shown in FIG. 19, the DO2i value is sent to a comparator 118 which compares it to a threshold value of  $DO2i_{crit}$  that is displayed in a window 154 (FIG. 20) of the display 111. This threshold value may be set at 270 ml/min/m<sup>2</sup> at a temperature between 34° C. and 37° C., and decreases as a function of temperature, in a linear fashion.

[0153] Therefore the threshold value of  $DO2i_{crit}$  be preset by the operator or may be calculated by a computing program 117 depending on the temperature value T determined by the temperature probe 140. The temperature T value determined by the probe 140 is sent to the display 111 to be displayed in a window 155.

[0154] When the DO2i value falls below the  $DO2i_{crit}$ , the comparing device sends a control signal to an alarm 116 that is triggered, alerting the operator of a potentially dangerous condition.

[0155] In some embodiments, the alarm 116 is not triggered by brief decreases of the pump flow Qp (often needed during CPB). Therefore, the alarm 116 could be set to be activated after 5 minutes of consecutive detection of a DO2i below the DO2i. However, a recording of all the periods of low flow can be made, to analyze and avoid the possibility that many short periods of low flow may create an additional effect. It is reasonable to consider no more than 20 minutes (as a total) of DO2i below the  $DO2i_{crit}$  during a normal CPB lasting about 90 minutes. The monitoring device 110 is equipped with a computing program 119, which receives as input values the exhaled carbon dioxide eCO2 as detected by the CO2 sensor 141 and the gas flow Ve set by the operator. According to these input data, the computing program 119 calculates the indexed carbon dioxide production VCO2i applying the equation (9).

[0156] The VCO2i value as calculated by the computing program 119 is sent to the display 111 and displayed in real time in a window 157 (FIG. 20) in its graphical relationship 158 as a function of time.

[0157] The VCO2i value is sent to a second comparator 120 which compares it with an anaerobic threshold value  $VCO2i_{crit}$  set by the operator; by default the  $VCO2i_{crit}$  is preset at 60 ml/min/m<sup>2</sup>. As shown in FIG. 20, the display 111 is provided with a window 159 showing the value of anaerobic threshold  $VCO2i_{crit}$  set by the operator.

[0158] Back to FIG. 19, when the VCO2i exceeds the  $VCO2i_{crit}$  an alarm signal is sent to a second alarm 121, which, when triggered, alerts the operator of a warning condition. Moreover, as shown in FIG. 20, the display 111 is provided with: a window 160 where the gas flow value Ve set by the operator is displayed; a window 161 where the indexed pump flow value Qpi arriving from the computing program 113 is displayed; and a window 162 where the body surface area of the patient is displayed as calculated by the computing program 112.

[0159] In some embodiments, the monitoring system 110 may be equipped with a data recording system and a printer interface, and/or a digital data recording system. The display 111 could include two configurations: a complete configura-

tion, as the one shown in FIG. 20, and a reduced configuration, only considering the DO2 parameter, as shown in FIG. 21.

[0160] In some embodiments, the DMS 29 may track and display a variety of different metabolic parameters. FIGS. 22 and 23 are screen captures providing illustrative but non-limiting examples of some of the metabolic parameters that can be displayed by the DMS 29. As discussed above, some of these parameters are measured while other parameters may be calculated by the DMS 29 using measured parameters. Examples of parameters include index oxygen delivery (DO2i), indexed oxygen consumption (VO2i), and indexed carbon dioxide production (VCO2i). Examples of ratios that may be displayed include  $DO2i/VCO2i$ ,  $VCO2i/VO2i$  and  $VO2i/DO2i$ .

[0161] Various modifications and additions can be made to the exemplary embodiments discussed without departing from the scope of the present invention. For example, while the embodiments described above refer to particular features, the scope of this invention also includes embodiments having different combinations of features and embodiments that do not include all of the above described features.

1. An integrated perfusion system comprising:
  - a heart lung machine including
  - a plurality of pump modules, each pump module having a control unit;
  - a controller in communication with each of the control units;
  - an input device in communication with the controller and configured to accept operational settings information from a user; and
  - an output device in communication with the controller and configured to display operational parameters of the plurality of pump modules;
- a data management system in communication with the controller, the data management system including
  - an RF sensor; and
  - a processor in communication with the RF sensor; and
- one or more disposable elements configured to be used in conjunction with the heart lung machine and including an RFID tag programmed with identifying information that can be read by the RF sensor and used by the processor to unlock functionality within the data management system.
2. The integrated perfusion system of claim 1, wherein the data management system is configured to receive and record data from the heart lung machine and optionally from external sources.
3. The integrated perfusion system of claim 2, wherein the data management system is configured to display data received from the heart lung machine and optionally from external sources.
4. The integrated perfusion system of claim 1, wherein the one or more disposable elements include one or more of a blood reservoir, an oxygenator, a heat exchanger, or an arterial filter.
3. The integrated perfusion system of claim 4, wherein the blood reservoir comprises a venous blood reservoir, a suction blood reservoir, a vent blood reservoir or a combination thereof.
6. The integrated perfusion system of claim 1, wherein the one or more disposable elements include a passive RFID tag.
7. The integrated perfusion system of claim 1, wherein the input device comprises a touch screen computer.

8. The integrated perfusion system of claim 1, wherein the functionality comprises a metabolic algorithm.

9. The integrated perfusion system of claim 1, wherein the RFID tag is further programmed with information identifying performance characteristics of the one or more disposable elements.

10. The integrated perfusion system of claim 9, wherein the data management system is configured to display a priming volume simulator utilizing the identified performance characteristics of the one or more disposable elements.

11. A method of configuring an integrated perfusion system including a heart lung machine and a data management system, the data management system including an RF sensor, the method comprising steps of:

attaching a disposable component having an RFID tag to the heart lung machine;  
reading the RFID tag with the RF sensor;

unlocking functionality within the data management system in accordance with information read from the RFID tag; and  
operating the unlocked functionality.

12. The method of claim 11, wherein operating the unlocked functionality comprises displaying a metabolic algorithm.

13. The method of claim 11, wherein operating the unlocked functionality comprises displaying a priming volume simulator in accordance with information read from the RFID tag.

14. The method of claim 11, further comprising displaying information provided from the RFID tag to the RF sensor.

15. The method of claim 11, wherein attaching the disposable component having an RFID tag to the heart lung machine precedes reading the RFID tag with the RF sensor.

\* \* \* \* \*