

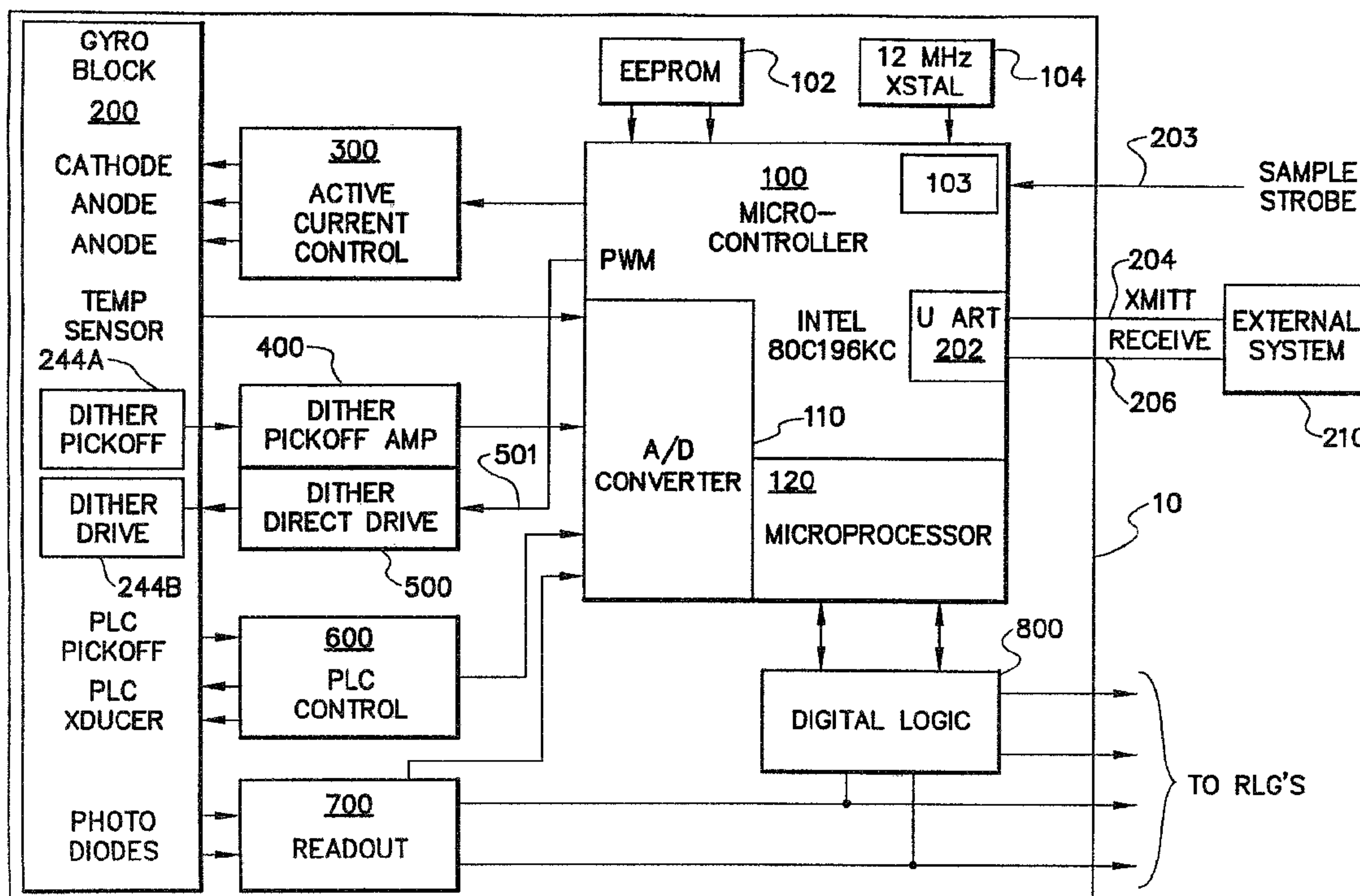

(86) Date de dépôt PCT/PCT Filing Date: 1993/07/16  
 (87) Date publication PCT/PCT Publication Date: 1994/02/03  
 (45) Date de délivrance/Issue Date: 2003/05/27  
 (85) Entrée phase nationale/National Entry: 1994/11/14  
 (86) N° demande PCT/PCT Application No.: US 1993/006686  
 (87) N° publication PCT/PCT Publication No.: 1994/002808  
 (30) Priorité/Priority: 1992/07/17 (07/922,612) US

(51) Cl.Int.<sup>5</sup>/Int.Cl.<sup>5</sup> G01C 19/66  
 (72) Inventeurs/Inventors:  
 KILLPATRICK, JOSEPH E., US;  
 FRITZE, KEITH R., US;  
 BERNDT, DALE F., US  
 (73) Propriétaire/Owner:  
 HONEYWELL INC., US  
 (74) Agent: SMART & BIGGAR

(54) Titre : CONFIGURATION ET COMMANDE D'UN GYROLASER PAR MICROPROCESSEUR  
 (54) Title: LASER GYRO MICROPROCESSOR CONFIGURATION AND CONTROL



(57) Abrégé/Abstract:

A laser gyro configuration and control (10) using a microprocessor (120). The microprocessor (120) has a high speed peripheral transaction system (201) which communicates through a high speed Universal Asynchronous Receiver Transmitter (UART) (202) to a serial to parallel converter (212) through a five Byte first in first out (FIFO (216) to an external system processor (224), The external system processor (224) sends information in a serial fashion through a single byte parallel to serial converter (208) to the high speed UART (202). Various information including gyro parameter load commands, gyro control commands, gyro status commands, and gyro calibration and diagnostic commands are sent over channels. The system provides a high speed method of controlling the laser gyro (10) and configuring it with a processor with serial transmit and receive lines.



INTERNATIONAL APPLICATION PUBLISHED UNDER THE PATENT COOPERATION TREATY (PCT)

<p>(51) International Patent Classification <sup>5</sup> : <b>G01C 19/66</b></p>	<p><b>A1</b></p>	<p>(11) International Publication Number: <b>WO 94/02808</b> (43) International Publication Date: <b>3 February 1994 (03.02.94)</b></p>
<p>(21) International Application Number: <b>PCT/US93/06686</b> (22) International Filing Date: <b>16 July 1993 (16.07.93)</b> (30) Priority data: <b>07/922,612</b>      <b>17 July 1992 (17.07.92)</b>      <b>US</b> (71) Applicant: <b>HONEYWELL INC. [US/US]; Honeywell Plaza, Minneapolis, MN 55408 (US).</b> (72) Inventors: <b>KILLPATRICK, Joseph, A. ; 2901 32nd Avenue Northeast, Minneapolis, MN 55418 (US). FRITZE, Keith, R. ; 4921 Sparrow Road, Minnetonka, MN 55345 (US). BERNDT, Dale, F. ; 335 Pineview Lane North, Plymouth, MN 55441 (US).</b></p>		<p>(74) Agent: <b>CHAMPION, Ronald, E.; Honeywell Inc., Honeywell Plaza - MN12-8251, Minneapolis, MN 55408 (US).</b> (81) Designated States: <b>CA, JP, European patent (AT, BE, CH, DE, DK, ES, FR, GB, GR, IE, IT, LU, MC, NL, PT, SE).</b>  <b>Published</b> <i>With international search report. Before the expiration of the time limit for amending the claims and to be republished in the event of the receipt of amendments.</i></p>

2135775

(54) Title: LASER GYRO MICROPROCESSOR CONFIGURATION AND CONTROL

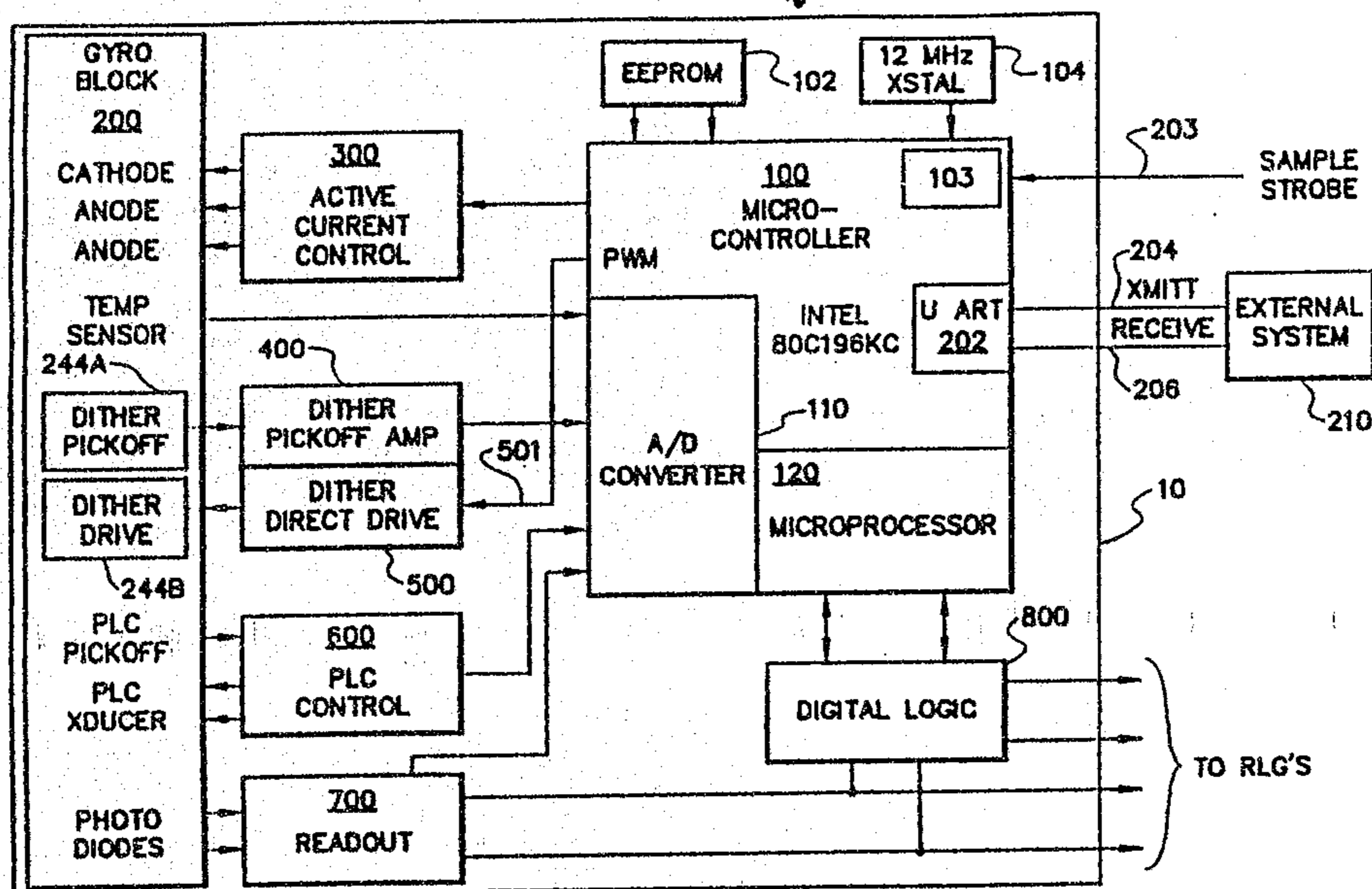

(57) Abstract

A laser gyro configuration and control (10) using a microprocessor (120). The microprocessor (120) has a high speed peripheral transaction system (201) which communicates through a high speed Universal Asynchronous Receiver Transmitter (UART) (202) to a serial to parallel converter (212) through a five Byte first in first out (FIFO) (216) to an external system processor (224). The external system processor (224) sends information in a serial fashion through a single byte parallel to serial converter (208) to the high speed UART (202). Various information including gyro parameter load commands, gyro control commands, gyro status commands, and gyro calibration and diagnostic commands are sent over channels. The system provides a high speed method of controlling the laser gyro (10) and configuring it with a processor with serial transmit and receive lines.

64159-1318

-1-

**LASER GYRO MICROPROCESSOR CONFIGURATION AND CONTROL**

This invention relates to a method of configuring and controlling a laser gyro using a microprocessor and more particularly to a method of configuring and controlling a laser gyro with a high speed microprocessor based communication system.

**BACKGROUND OF THE INVENTION**

Ring laser angular rate sensors, also called laser gyros, are well known in the art. One example of a ring laser angular rate sensor is US Patent No. 4,751,718 issued to Hanse, et al. Present day ring laser angular rate sensors include a thermally and mechanically stable laser block having a plurality of formed cavities for enclosing a gap. Mirrors are placed at the extremities of the cavities for reflecting laser beams and providing an optical closed-loop path. Such a laser gyro may incorporate a microprocessor controller.

Laser gyros that utilize microprocessors for their control require that inertial navigation information, control information, test information, and status information be communicated to external systems including an inertial navigation system or a test system. The inclusion of a microprocessor in the laser gyro allows the implementation of new capabilities such as sending autonomous control functions and self testing along with self calibration and self diagnostics. This new capability requires the transmission and reception of a broad spectrum of data, some of which occurs at a high frequency rate. This laser gyro and a system using this laser gyro are discussed in "GG1308 RING LASER GYRO INERTIAL MEASUREMENT SYSTEMS - HONEYWELL'S LOW COST SOLUTION FOR TACTICAL APPLICATIONS" in IEEE Plans 20 March 1990, pp 528-536. The

64159-1318

-2-

article discusses a small, low cost inertial sensor and system. The system includes a three laser gyros, three accelerometers, a high voltage power supply, low voltage power connection and dither and path length control systems  
5 in a common housing. External system support electronics and software are connected to the elements inside the housing through glass to metal sealed pins.

### SUMMARY OF THE INVENTION

The invention provides a laser gyro configuration  
10 and control mechanism that utilizes an onboard microcontroller with a high speed Universal Asynchronous Receiver Transmitter (UART) that interfaces through a transmit line and a receive line to an external system. The microprocessor communicates through a set of predetermined  
15 registers that have a structure lending itself to high speed data communications. The microprocessor sends a command tag along with inertial navigation data and status data. The external system communicates to the laser gyro through a similar mechanism. The laser gyro includes a personality  
20 storage module in nonvolatile memory that stores gyro operating parameters for start up.

It is an object of the invention to provide a laser gyro with a high speed data communications system.

It is yet another object of the invention to  
25 provide a laser gyro high speed interface that uses a microprocessor controlled UART and a transmit line and receive line.

It is yet a further object of the invention to  
30 provide a laser gyro high speed interface to an external system that uses an output command frame and input command

64159-1318

-2a-

frame.

In accordance with one aspect of the invention there is provided a laser gyro configuration and control apparatus, comprising: a laser gyro having at least one control input; laser gyro control means connected to at least one control input to control the laser gyro in response to configuration and control commands; an external system connected to the laser gyro control means, said external system providing configuration and control commands to the laser gyro control means; means for communicating connected from the external system to the laser gyro control means, said means for communicating having a transmit line and a receive line to transmit and receive data from the external system; wherein the means for communicating communicates a command comprising: (a) a first delta theta byte comprised of a plurality of data bits encoding a first byte of an angular displacement of the laser gyro; (b) a second delta theta byte comprising a second byte of the angular displacement of the laser gyro; (c) a first status byte comprised of a plurality of bits comprising a status of the laser gyro; and (d) a second status byte comprised of a plurality of bits describing a status of the laser gyro.

In accordance with another aspect of the invention there is provided a laser gyro configuration and control apparatus comprising: (a) a first serial communication means for communicating wherein the first serial communication means communicates a first serial bit stream on a serial output line and receives a second serial bit stream on a serial input line; (b) a second serial communication means for communicating connected to receive serial data from the first serial communication means, wherein the second serial communication means has a serial parallel converter connected to receive data from the first serial

64159-1318

-2b-

communication means on the serial output line and further  
having a parallel byte output; (c) a third serial  
communication means for converting a parallel byte to serial  
byte data connected to the serial input line to send serial  
5 data; (d) a multibyte first in first out queuing means  
connected to receive parallel data from the second serial  
communication means such that the information converted from  
serial to parallel is communicated to the multibyte first in  
first out queuing means in a first in first out fashion  
10 wherein the first in byte is sent to a FIFO output line; (e)  
an interface logic means connected to the FIFO output line  
to receive data bytes from the multibyte first in first out  
queuing means having an external processor interface; (f) an  
external microprocessor system used for controlling a laser  
15 gyro connected to the external processor interface; (g) a  
peripheral transaction system; (h) a receiver-transmitter  
means connected to the peripheral transaction system such  
that the peripheral transaction system schedules  
communications between the first, second and third serial  
20 communication means; and (i) a control means for controlling  
the peripheral transaction system to enable the  
communication of the serial data from the first serial  
communication means, second serial communication means, and  
third serial communication means.

2135775

-3-

Other objects, features and advantages of the present invention will become apparent to those skilled in the art through the description of the preferred embodiment, claims and drawings herein where like numerals refer to like elements.

#### BRIEF DESCRIPTION OF THE DRAWINGS

Figure 1 shows the laser gyro apparatus of the invention with the high speed interface.

Figure 2 shows the apparatus of the invention in a detailed schematic drawing to provide a high speed interface for a laser gyro.

Figure 3 shows the output frame structure for the command data format sending data from the laser gyro to the external system processor.

Figure 4 shows the input frame buffer for sending data from the external system to the laser gyro.

Figure 5 shows a method of communicating between the external system and the laser gyro.

#### DESCRIPTION OF THE PREFERRED EMBODIMENTS

Referring now to Figure 1 which shows a block diagram of one embodiment of a modular laser gyro employing the novel features of the present invention. The instant invention will be explained by way of example embodiments. Those skilled in the art having the benefit of this disclosure will appreciate that the examples herein are by way of illustration of the principles of the invention and not by way of limitation. Laser gyro system 10 includes a controller 100, a laser gyro block 200, an active current control 300, dither pickoff amplifier 400, direct digital dither drive 500, a path length control (PLC) device 600, a readout 700, and digital logic 800. The controller 100 further includes a Universal Asynchronous Receiver Transmitter (UART) 202 which

**SUBSTITUTE SHEET**

2135775

-4-

communicates to an external system 210 through transmit line 206 and receive line 204.

Now referring to Figure 2 which shows a hardware diagram of the apparatus of the invention. The apparatus is used to interface a laser gyro controller 100 to an external system 210. The laser gyro system 10 includes a microprocessor 120. The microprocessor 120 includes a high speed UART 202 controlled by a peripheral transaction system (PTS) 201. The UART 202 communicates to the external system 210 on transmit line 206 and receive line 204. Line 206 is connected to the external system 210 through a serial to parallel converter 212. The serial to parallel converter 212 provides information on line 218 to a five Byte FIFO 216. The five Byte FIFO 216 interfaces to processor interface logic 214 which provides information to an external system processor 224 for further processing. The interface logic 214 provides commands from the external system processor 224 through serial interface line 222 to a single byte parallel to serial converter 208. The single byte parallel to serial converter 208 provides information to the laser gyro microprocessor 120 on receive line 204.

The apparatus of Figure 2 provides a way of communicating high speed serial data to a queue in the serial to parallel converter 212. The system provides a five Byte FIFO 216 with high speed interface data that can be accepted by the external processor 224. The apparatus of Figure 2 provides a bi-directional means by which information can flow between the two processors 120, 224 at a very high rate.

The microprocessor controlled configuration and control of the laser gyro 10 is accomplished through the use of a command set. These commands are generally defined in four types. The four command types for the laser gyro are, (1) the parameter load commands, (2)

SUBSTITUTE SHEET



2135775

the gyro control commands, (3) the gyro read status commands, and (4) the gyro calibration and diagnostics commands. (1) PARAMETER LOAD COMMANDS

Parameter load commands provide a way of loading constants into the microprocessor's EEPROM 102. Parameter load commands can be of two types. The first type is a one-word command, the second type is a two-word command. In one example embodiment of the invention a word is defined as sixteen bit unsigned quantity.

Two-word parameter load commands fall into the types of commands requiring a two byte physical address in the EEPROM 102, for example: command 0 hexadecimal loads the K1 constant into the EEPROM at word addresses 0 and 1; and command 1 loads the constant K2 into word addresses 2 and 3, etc. These commands occupy the 0-F hexadecimal address location. These constants occupy word addresses 0-1FH in the EEPROM 102. The following table lists two-word parameter load commands.

20

TABLE A

- 1. CMD 0H - Load compensation constant K1.
- 2. CMD 1H - Load compensation constant K2.
- 3. CMD 2H - Load compensation constant K3.
- 4. CMD 3H - Load compensation constant K4.
- 25 5. CMD 4H - Load compensation constant K1.
- 6. CMD 5H - Load compensation constant K12.
- 7. CMD 6H - Load compensation constant K7.
- 8. CMD 7H - Load compensation constant K9.
- 9. CMD 8H - Load Serial Number.
- 30 10. MD 9H - Load Build Date.
- 11. CMD AH - Load Alignment X.
- 12. CMD BH - Load Alignment Y.
- 13. CMD CH - Load Current (min,max) Limits; microamperes.
- 35 14. CMD DH - Load Power (min,max) Limits. Power is in milliwatts.

2135775

-6-

15           CMD EH - Load initial Dither stripper  
AGC gain constant.

One-word parameter load commands are loaded into  
EEPROM 102 starting at address 40H. These command  
5 codes represent the physical address in the EEPROM 102  
where data is to be stored. These commands are listed  
below with explanations in Table B.

TABLE B

- 10           1. CMD 20H - Load Operating Hours. This command  
initializes the operating hours to a value  
specified in command parameter 1 into the  
EEPROM.
2. CMD 21H - Load Dither Frequency. This command  
loads the dither frequencies, in Hz, into the  
15 EEPROM.
3. CMD 22H - Load Dither Command Angle. This  
command loads the dither command angle into the  
EEPROM. This value is used by the modular gyro  
system during power-on to set the initial  
20 command angle.
4. CMD 23H - Load PLC Mode Ref Voltage. This  
command loads the PLC mode reference voltage  
into the EEPROM.
5. CMD 24H - Set laser run current. This is a 4  
25 bit value to set the initial laser run current.

\* \*       -END-       \* \*

## (2) GYRO CONTROL COMMANDS

Gyro control commands are those commands that  
either set the gyro operating parameters or alter gyro  
30 dither angle or write the parameters check sum. These  
commands include a "set gyro operating parameters"  
command, an "alter gyro dither angle" command, a "write  
parameters check sum" command, and "gyro read status  
commands". The gyro read status commands include a  
35 "read current control loop current" command, a "read  
temperature" command, a "readout intensity monitor"

SUBSTITUTE SHEET

2135775

-7-

command, a "read operating hours" command, a "read time to fail" command and diagnostic and calibration commands.

The set gyro operating parameters command  
5 changes the operating modes of the gyro. Various bits are associated with various operating states of the gyro. The command code for the "set gyro operating parameters" command is 30H. Bit 0 of the command selects either constant current or constant power  
10 operation. Bit 1 is used to restart the system. Bit 2 is used to turn the compensation on or off for the gyro. Bit 3 is used to turn the noise for the gyro on or off.

The next command used in the gyro control  
15 command set is the "alter gyro dither angle" command. This command allows the dither angle to be altered to a value specified by the first parameter word in the command. The command code for this command is 31H.

The next command for the gyro control command  
20 set is the "write parameters check sum" command. This command generates an overall check sum on the parameters currently in the EEPROM 102 and stores this value in the EEPROM 102. This check sum is used to determine whether or not the EEPROM 102 was loaded with  
25 the correct information or expected information.

### (3) GYRO READ STATUS COMMANDS

The gyro read status commands allow gyro system functions to be monitored. These commands begin at address 40H. The first read status command is command  
30 40H which is a "read current control loop current" command. This command returns the current control loop current from the gyro 10. The information returned is in microamperes. A "read temperature" command, address 41H, returns the current gyro temperature in degrees  
35 Kelvin. A "readout intensity monitor (RIM)" command, address 42H, returns the current RIM signal level. A

SUBSTITUTE SHEET

2135775

-8-

"read operating hours" command returns the number of hours to the nearest hour that the gyro 10 has been in active operation. This command's address is 43H. A "read time to fail" command, address 44H, returns the remaining number of hours the gyro has until a failure may occur as, for example, predicted by a lifetime prediction method. Command addresses 50H-5FH read the calibration constants used for the gyro.

#### (4) GYRO CALIBRATION AND DIAGNOSTICS

The final commands are the enter calibration mode or diagnostic mode commands which are commands that enable the gyro to execute routines to calibrate itself or diagnose potential problems.

Referring now to Figure 3 which shows the structure of the UART output command buffer for the UART 202 in controller 100. When information is sent from the controller 100 to the external system processor 224 the information is transmitted in a five byte structure called a frame. The output buffer frame 230 comprises a command tag 232, a delta theta byte one 234, a delta theta byte two 236, a status byte one 238, and a status byte two 240. The command tag 232 is a reference to the type of operational status which is being returned. The delta theta byte one 234 and delta theta byte two 236 are the dither stripped, compensated inertial navigation measurements of the laser gyro 10. Status byte one 238 and status byte two 240 are the information resulting from the command.

The serial output data character format is asynchronous and 10 bits in length in one embodiment of the invention. The data is in the format of one start bit, one stop bit, and 8 data bits. In one embodiment of the invention the maximum clock rate is 12 megahertz resulting in a 750 Kbaud communication rate.

Now referring to Figure 4 which shows the laser gyro of the invention's input frame format. The input

**SUBSTITUTE SHEET**

2135775

-9-

frame 242 is comprised of a number of elements. The first element is a command tag similar to the output buffer frame 230. Command tag 244 provides the microprocessor 120 of the laser gyro a validity flag used to verify a write command. The EEPROM address one 246 and EEPROM address two 248 contain the location in the EEPROM 102 of the data to be stored. The data byte one 250 and data byte two 252 provide the actual data to be stored into the EEPROM 102 at EEPROM address one 246 and EEPROM address two 248.

Data is sent through the output channel from the gyro 10 to the external system 210 continuously at a predetermined update rate. The update rate is equal to the sample clock rate. The sample rate provide current inertial navigation data to the external system 210 from the microprocessor 120. The data provided may also include other information encoded in the status bytes.

Now referring to Figure 5 which shows the method of the invention used to communicate between an external system 210 and the system controller 100 for the laser gyro 10. The external system 210 could alternately include an inertial navigation system or a laser gyro test system. The external system 210 is responsible for loading a command into the command buffer frame 230 at step 822. The command structure is shown in more detail with reference to Figure 3 as discussed hereinabove. The command is communicated over the receive line 204.

At the end of the peripheral transaction server interrupt the "command buffer full" flag is set. The UART 202 generates an interrupt which sets the "command buffer full" flag in step 824. The process of Figure 5 then flows to enter the monitor control loop 390 and at step 826 checks whether or not the command buffer is full. If the command buffer is not full the process

SUBSTITUTE SHEET

2135775

-10-

flows to step 832 to continue execution of the monitor control loop 390. If the command buffer frame 230 is full the process flows to decoding the command in step 828 and the process executes the command decoded in step 828 and step 830. The process then flows to step 832 to the gyro. The process then flows to check the "command buffer full" flag in step 826 and repeats.

In one alternate embodiment of the invention the laser gyro microprocessor controller further includes a personality storage module which may alternatively be in a second EEPROM or nonvolatile memory 103. The nonvolatile memory personality storage module stores certain operating characteristics of the gyro such as the path length control mirror positions and other operating characteristics of the gyro. The personality storage module also stores system specific information that may vary from system to system. This system specific information is determined at build time during the manufacturing process. These generating characteristics may be read or updated by the external system 210 using the communication apparatus of the invention.

In one embodiment of the invention the controller 100 is comprised of the Intel 80C196KC Microcontroller.

The invention has been described herein in considerable detail in order to comply with the Patent Statutes and to provide those skilled in the art with the information needed to apply the novel principles and to construct and use such specialized components as are required. However, it is to be understood that the invention can be carried out by specifically different equipment and devices, and that various modifications, both as to the equipment details and operating procedures, can be accomplished without departing from the scope of the invention itself. For example, the

SUBSTITUTE SHEET

2135775

-11-

configuration and control loop method of the invention may optionally delete process steps relating to Random Drift Improvement and gyro life prediction.

What is claimed is:

**SUBSTITUTE SHEET**

64159-1318

-12-

CLAIMS:

1. A laser gyro configuration and control apparatus, comprising: a laser gyro having at least one control input; laser gyro control means connected to at least one control  
5 input to control the laser gyro in response to configuration and control commands; an external system connected to the laser gyro control means, said external system providing configuration and control commands to the laser gyro control means; means for communicating connected from the external  
10 system to the laser gyro control means, said means for communicating having a transmit line and a receive line to transmit and receive data from the external system; wherein the means for communicating communicates a command comprising:

15 (a) a first delta theta byte comprised of a plurality of data bits encoding a first byte of an angular displacement of the laser gyro;

(b) a second delta theta byte comprising a second byte of the angular displacement of the laser gyro;

20 (c) a first status byte comprised of a plurality of bits comprising a status of the laser gyro; and

(d) a second status byte comprised of a plurality of bits describing a status of the laser gyro.

2. A laser gyro configuration and control apparatus  
25 comprising:

(a) a first serial communication means for communicating wherein the first serial communication means communicates a first serial bit stream on a serial output  
30 input line;



64159-1318

-13-

(b) a second serial communication means for communicating connected to receive serial data from the first serial communication means, wherein the second serial communication means has a serial parallel converter  
5 connected to receive data from the first serial communication means on the serial output line and further having a parallel byte output;

(c) a third serial communication means for converting a parallel byte to serial byte data connected to  
10 the serial input line to send serial data;

(d) a multibyte first in first out queuing means connected to receive parallel data from the second serial communication means such that the information converted from serial to parallel is communicated to the multibyte first in  
15 first out queuing means in a first in first out fashion wherein the first in byte is sent to a FIFO output line;

(e) an interface logic means connected to the FIFO output line to receive data bytes from the multibyte first in first out queuing means having an external processor  
20 interface;

(f) an external microprocessor system used for controlling a laser gyro connected to the external processor interface;

(g) a peripheral transaction system;

25 (h) a receiver-transmitter means connected to the peripheral transaction system such that the peripheral transaction system schedules communications between the first, second and third serial communication means; and

(i) a control means for controlling the peripheral  
30 transaction system to enable the communication of the serial

64159-1318

-14-

data from the first serial communication means, second serial communication means, and third serial communication means.

3. The laser gyro configuration and control apparatus  
5 of claim 2 wherein the control means further comprises an Intel 80C196KC Microcontroller.

4. The apparatus of claim 2 wherein the first serial  
communication means, the second serial communication means  
and the third serial communication means communicates a  
10 command tag comprising:

(a) a first EEPROM address byte comprised of a  
plurality of bits;

(b) a second EEPROM address byte comprised of a  
plurality of bits,

15 (c) a first data byte; and

(d) a second data byte.

5. The laser gyro configuration and control apparatus  
of claim 2 wherein the laser gyro has operating parameters  
and wherein the control means further comprises a  
20 personality storage means to store the operating parameters.

6. The laser gyro configuration and control apparatus  
of claim 5 wherein the personality storage means further  
comprises a nonvolatile memory.

7. The laser gyro configuration and control apparatus  
25 of claim 6 wherein the personality storage means further  
comprises an EEPROM.

8. The apparatus of claim 2 wherein the serial data  
further comprises a command that has a description following

64159-1318

-15-

the structure of a command tag constructed of a plurality of data bits.

9. The apparatus of claim 2 wherein the serial data comprises:

5 (a) a first delta theta byte comprised of a plurality of data bits encoding a first byte of an angular displacement of the laser gyro;

(b) a second delta theta byte comprising a second byte of the angular displacement of the laser gyro;

10 (c) a first status byte comprised of a plurality of bits comprising a status of the laser gyro;

(d) a second status byte comprised of a plurality of bits describing a status of the laser gyro.

SMART & BIGGAR

PATENT AGENTS

OTTAWA, CANADA

Fig. 1

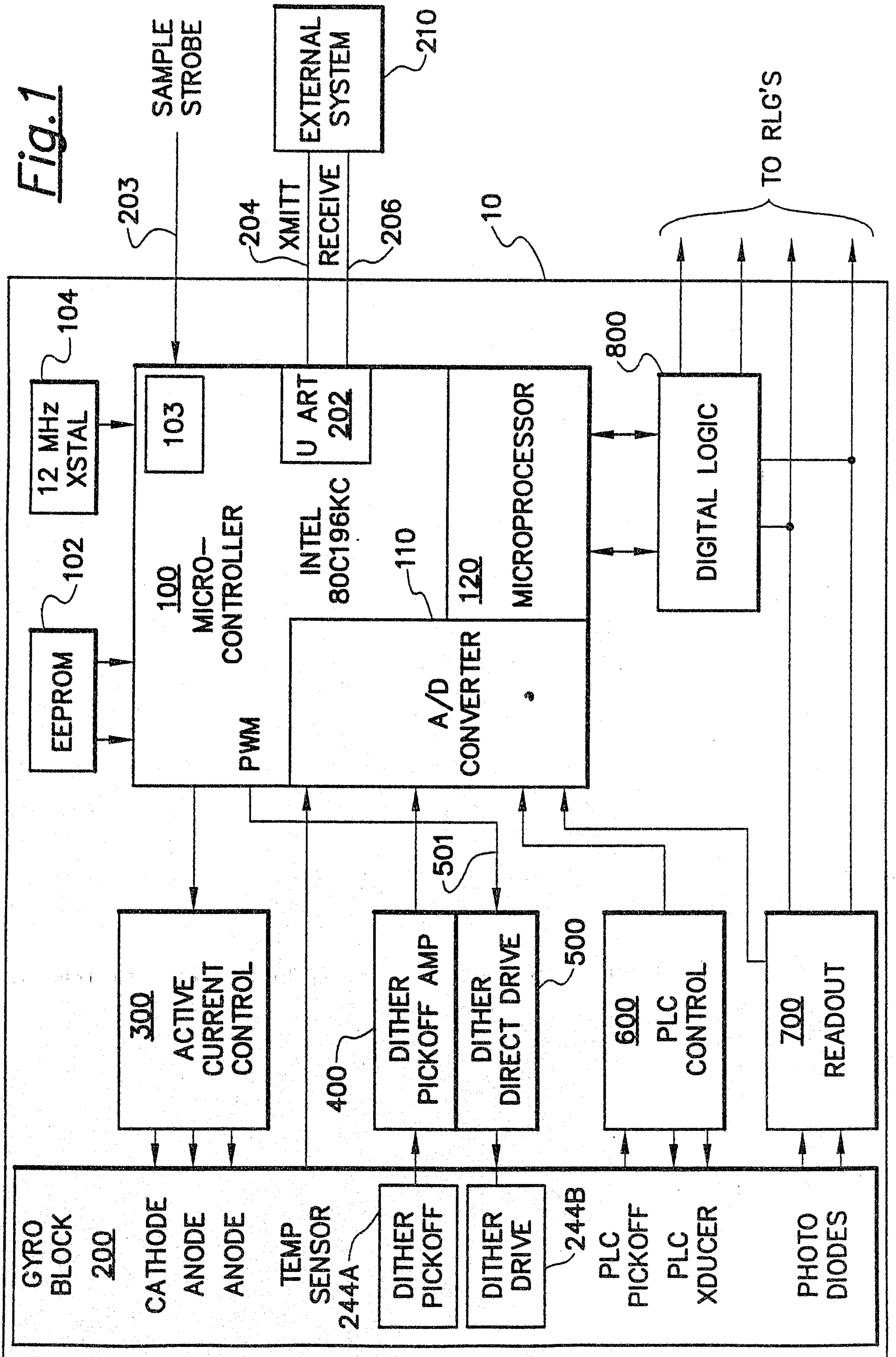

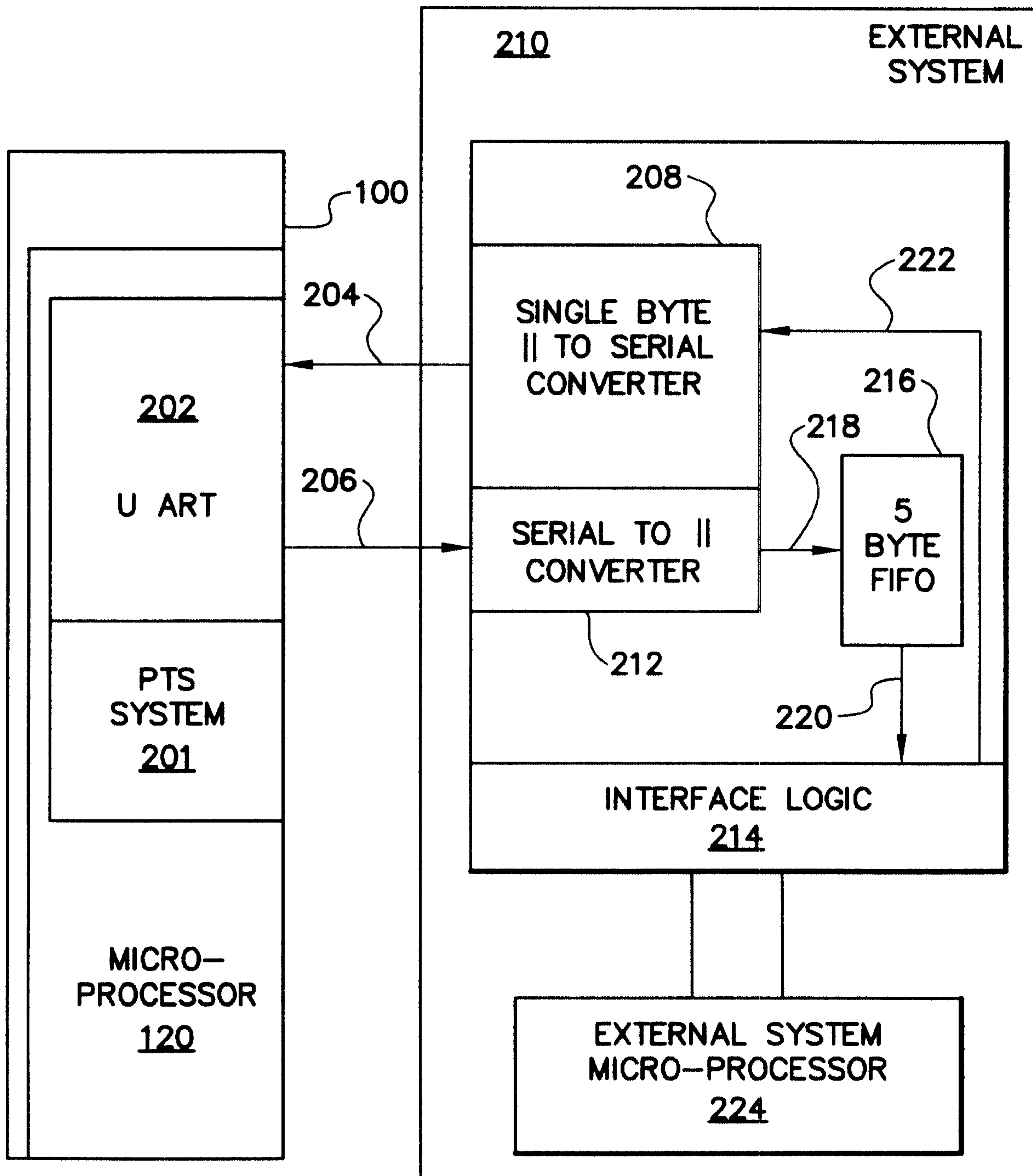

Fig.2

U ART OUTPUT  
COMMAND BUFFER

8 BITS

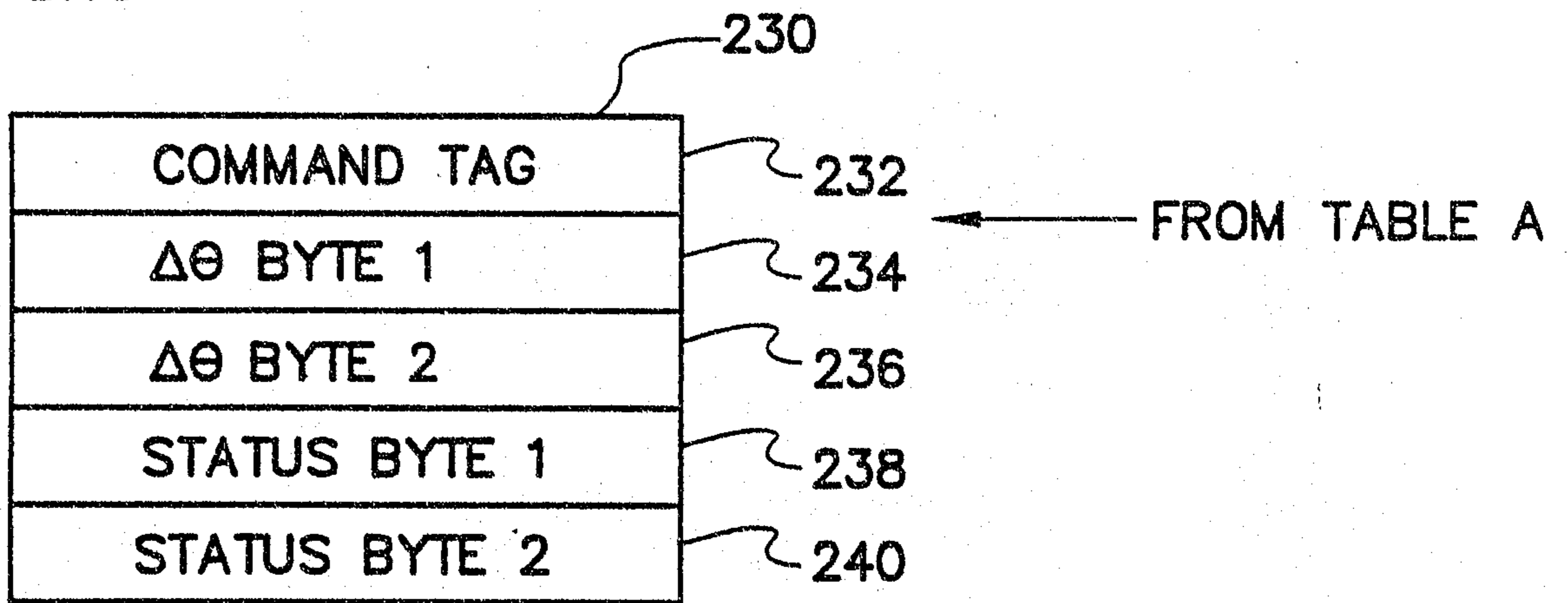

Fig. 3

INPUT FRAME

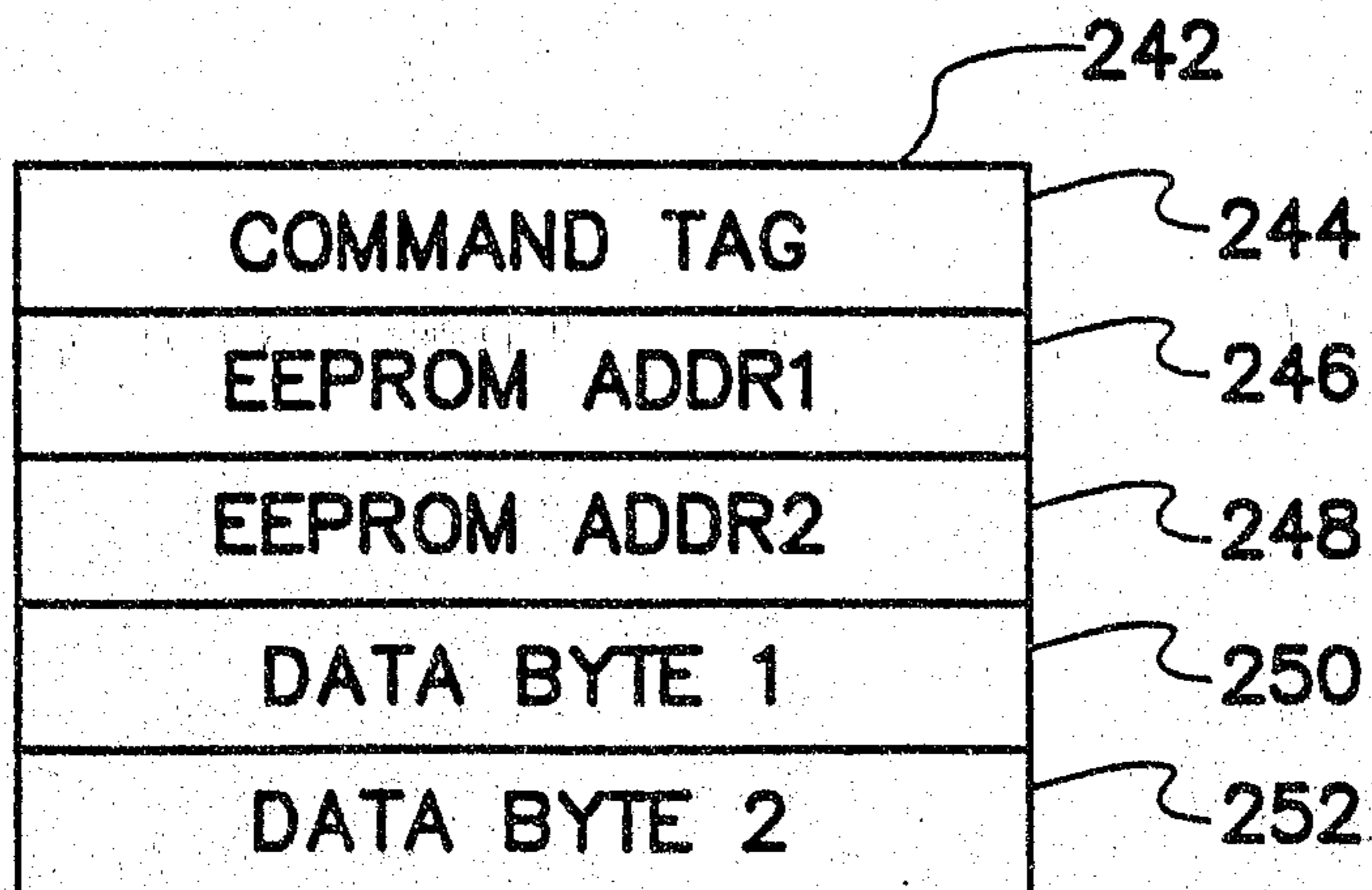

Fig. 4

4 / 4

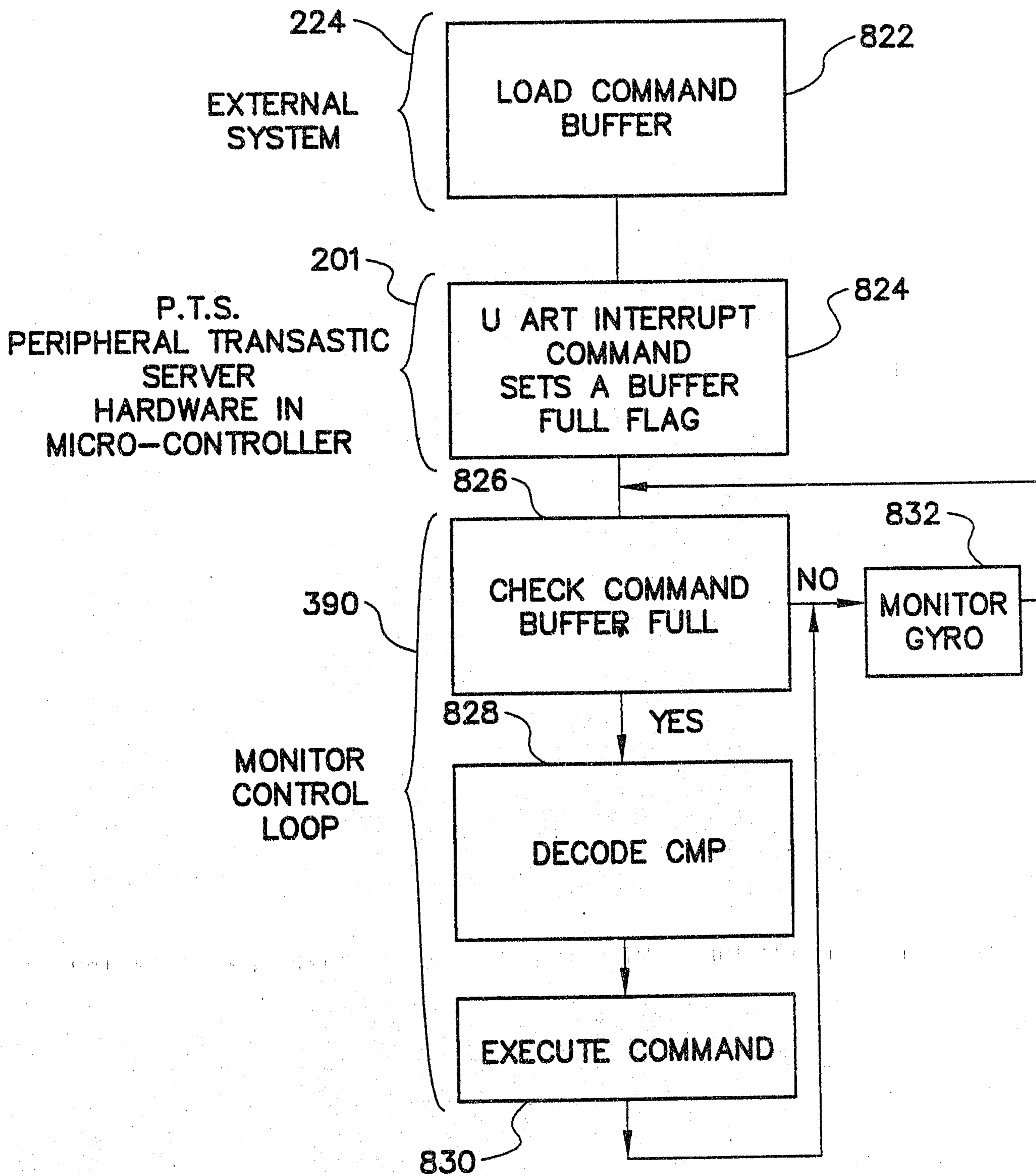

Fig. 5

