



US 20140083773A1

(19) **United States**

(12) **Patent Application Publication**  
**Minosyan et al.**

(10) **Pub. No.: US 2014/0083773 A1**

(43) **Pub. Date: Mar. 27, 2014**

(54) **RELIABILITY FOR ELECTROMAGNETIC DATA TELEMETRY FOR DOWNHOLE APPLICATION ON WELL DRILLING OPERATIONS**

**Publication Classification**

(51) **Int. Cl.**  
*E21B 47/00* (2006.01)  
(52) **U.S. Cl.**  
CPC ..... *E21B 47/00* (2013.01)  
USPC ..... **175/40**

(71) Applicant: **Nabors International, Inc.**, Houston, TX (US)

(72) Inventors: **Vadim Minosyan**, Conroe, TX (US);  
**Matthew White**, Spring, TX (US)

(73) Assignee: **Nabors International, Inc.**, Houston, TX (US)

(21) Appl. No.: **14/032,905**

(22) Filed: **Sep. 20, 2013**

**Related U.S. Application Data**

(60) Provisional application No. 61/706,030, filed on Sep. 26, 2012.

(57) **ABSTRACT**

A tool and associated methods for transmitting electromagnetic data telemetry from a downhole sensor during drilling operations. The tool may include a pressure housing, the pressure housing including an EM transmitter, receiver, or transceiver. A conductive element electrically coupled to the EM transmitter, receiver, or transceiver is positioned between an upper and a lower signal conductor positioned coaxially around the conductive element. The upper and lower signal conductors support the pressure housing and conductive element within the inner diameter of a drill collar and provide electrical connection between the conductive element and a section of the drill collar on either side of an insulated gap. In some embodiments, the conductive element is tensioned between the upper and lower signal conductors.

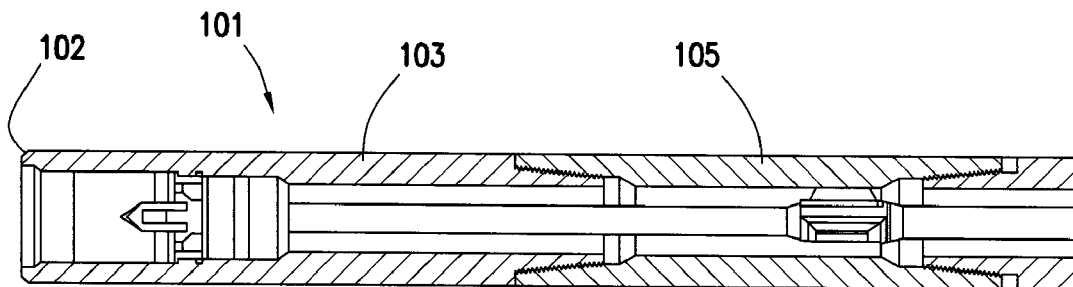

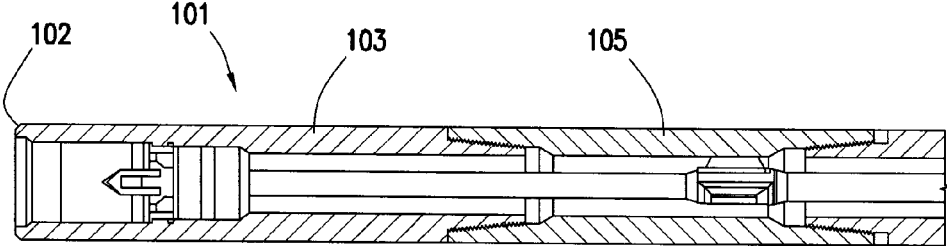

FIG. 1A

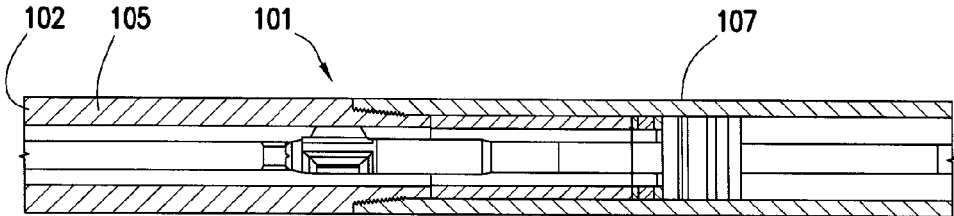

FIG. 1B

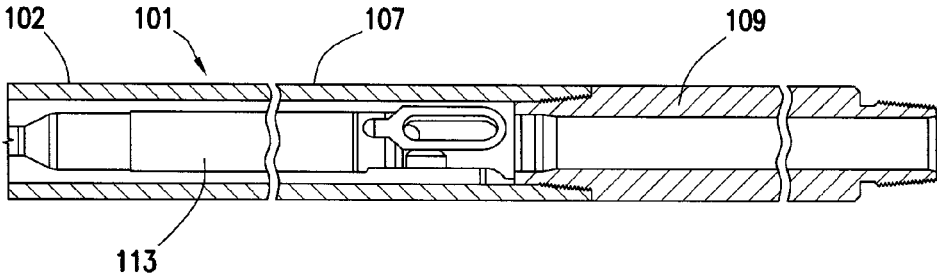

FIG. 1C

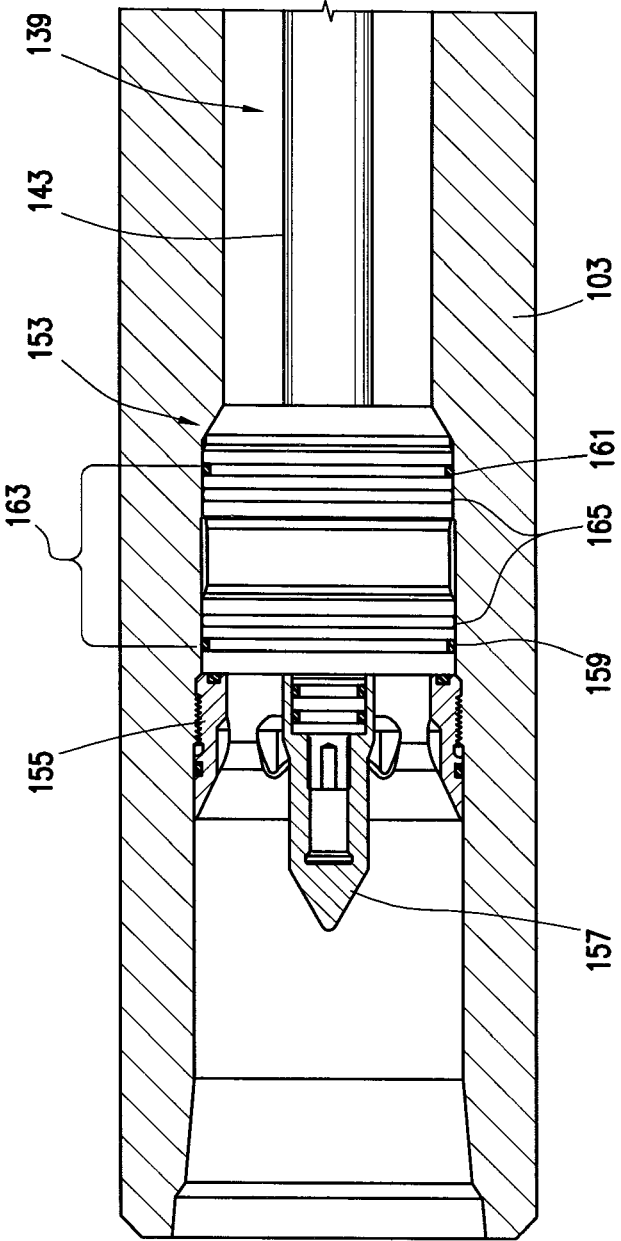

FIG. 2

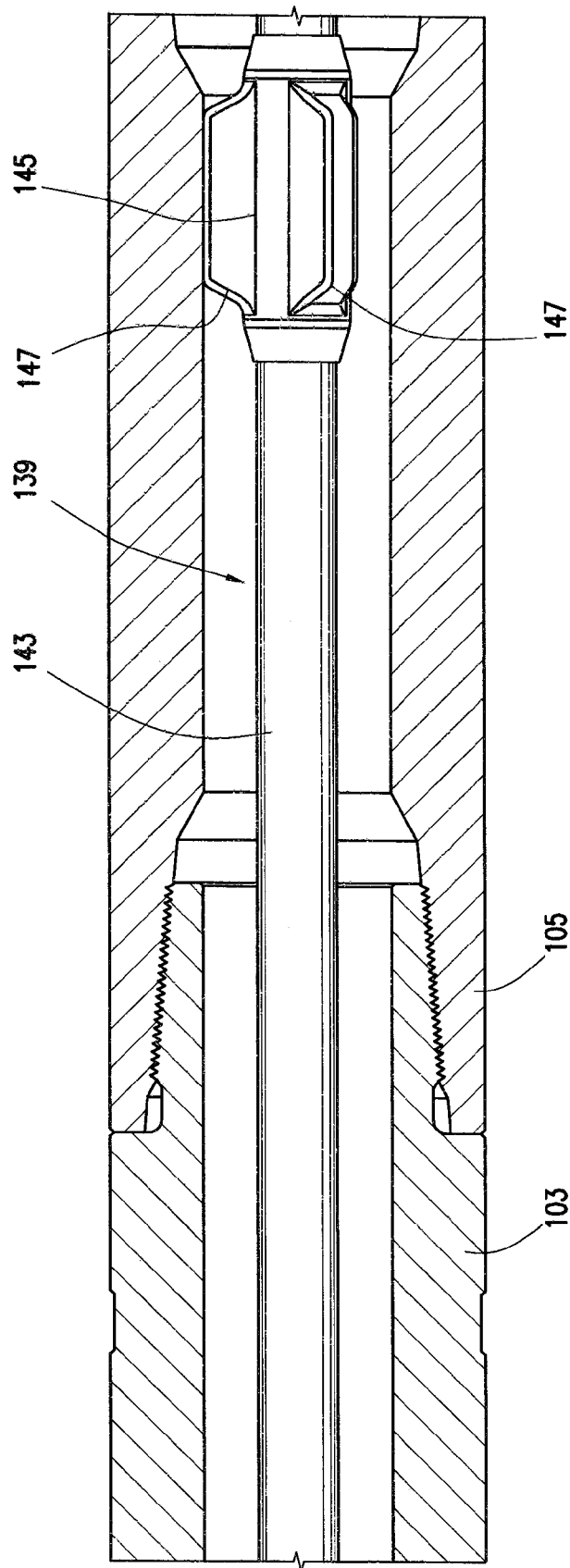

FIG. 3

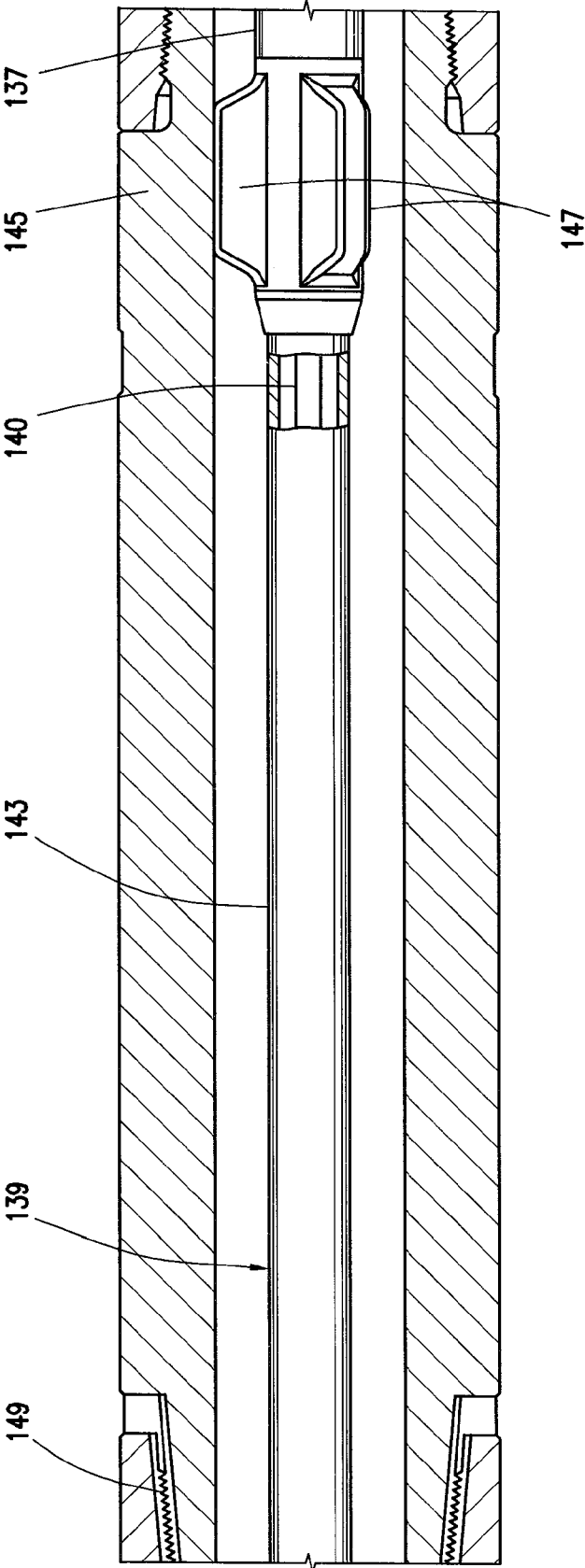

FIG. 4

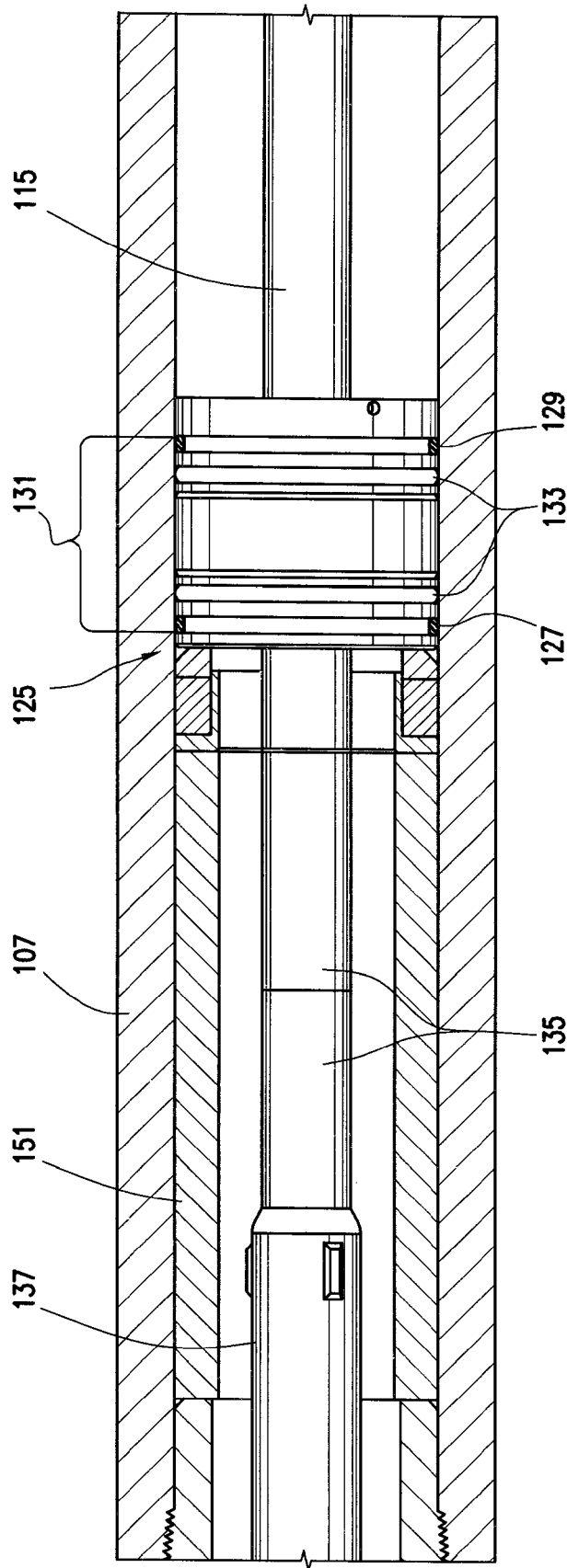

FIG. 5

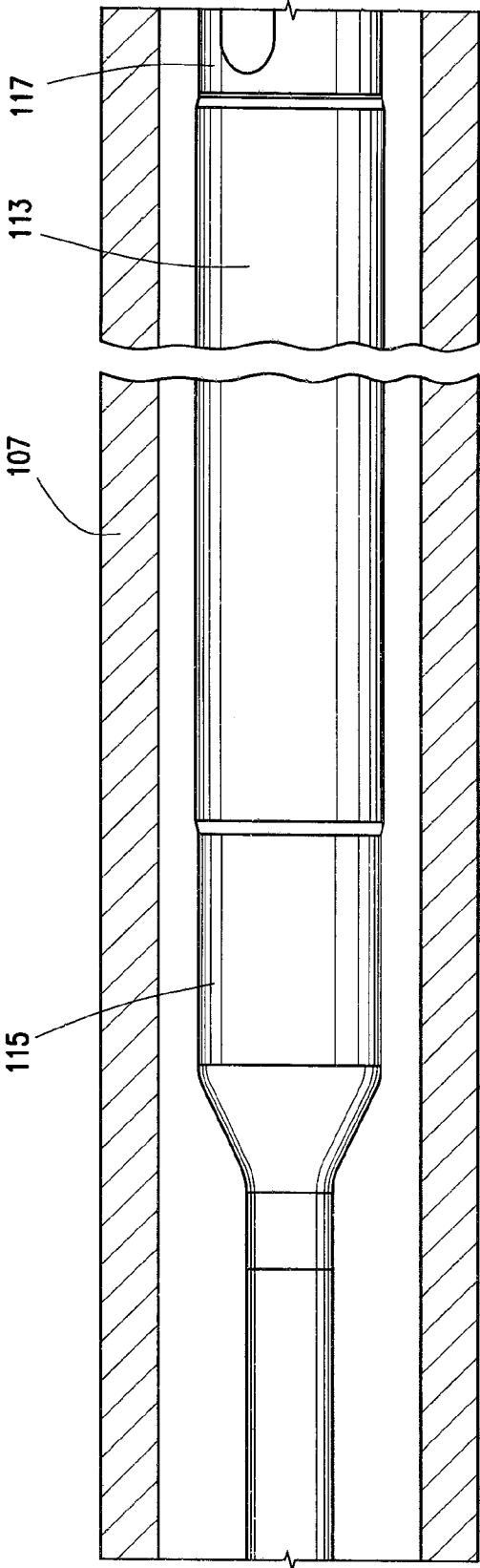

FIG. 6

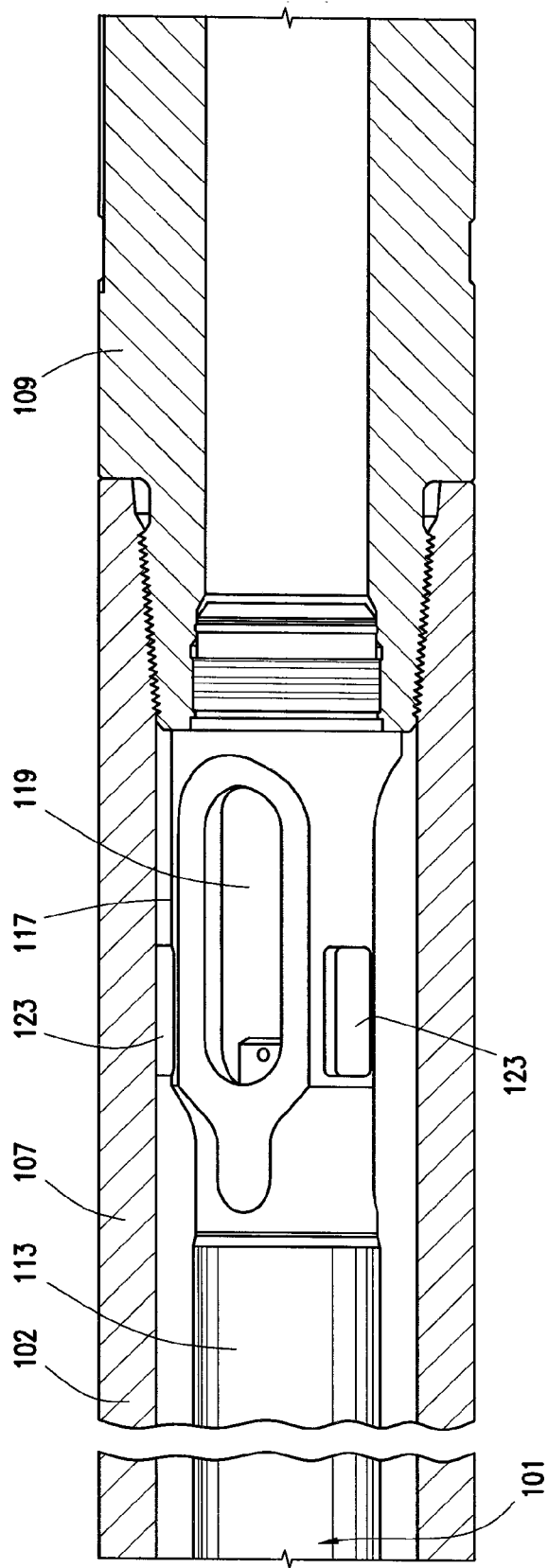

FIG. 7



**RELIABILITY FOR ELECTROMAGNETIC  
DATA TELEMETRY FOR DOWNHOLE  
APPLICATION ON WELL DRILLING  
OPERATIONS**

**CROSS-REFERENCE TO RELATED  
APPLICATIONS**

**[0001]** The present application claims priority from provisional U.S. Patent Application Ser. No. 61/706,030, filed Sep. 26, 2012.

**FIELD OF THE DISCLOSURE**

**[0002]** The present disclosure relates to the collection of data from sensors within a drill collar as part of a bottom hole assembly near the lower ends of a drill pipe stand while said pipe is in use in a downhole environment.

**BACKGROUND**

**[0003]** Downhole logging aids in determine the structural, physical and chemical properties of a formation being penetrated. Data is collected in the borehole. Traditionally Logging While Drilling (LWD) operations were recorded for later analysis while Measurement While Drilling (MWD) operations were transmitted to the surface to provide more immediate feedback. In many operations today the difference between the two has blurred, with tools which commonly log and transmit data to allow immediate feedback and still avoid data loss. For purposes of this discussion, the term MWD will be utilized and should be interpreted to indicate: MWD, LWD, and/or MWD+LWD.

**[0004]** Methods of transmission known to those skilled in the arts, may include but are not limited to: wireline transmission, modulated pressure waves/mud pulsing, and electromagnetic (EM) signal, wired drill pipe (i.e. intellipipe). Methods for transmitting data to the surface depend on the formation and drilling techniques utilized in a specific situation. For example, if compressible fluids are used for drilling, mud pulse telemetry data is lost in deeper wells. EM MWD technology may utilize earth formation as the medium to propagate a communications signal for the bottom of a wellbore to the surface. EM MWD may allow large quantities of real time data about a wellbore to be gathered during drilling operations. EM may be useful in environments where substantially incompressible drilling mud cannot be utilized for various reasons, which prevents to use of mud pulse telemetry as a data propagation medium.

**[0005]** Reliability of an EM MWD tool and specifically the communications system to the surface may be a significant factor in the effectiveness of the tool. A major application of EM MWD technology may involve wells where it is not possible to use liquid (termed drilling fluid or "mud") to flush cuttings to surface. In such environments compressed gas or foam is used in place of the mud. EM MWD may be useful in such situations due to the absence of mud as a transition medium to the surface for data. However, drilling mud may provide a significant dampening of shock and vibration in traditional well operations. Drilling without mud causes the levels of shock and vibration in the BHA to be significantly higher.

**[0006]** Typically EM systems may be considered to be more reliable and faster than mud pulse telemetry for transmission of down-hole data to surface, assuming the formations outside the wellbore are suitable for EM transmission.

However, in rough drilling conditions where high levels of shock and vibration are present, standard narrow probe systems with rubber centralizers or metal spring loaded centralizers are inadequate to maintain the required reliability of the down-hole tool and communications channel for the length of the operation.

**SUMMARY**

**[0007]** This disclosure provides for a tool for transmitting electromagnetic data telemetry from a downhole sensor during drilling operations. The tool may include a pressure housing, the pressure housing including an EM transmitter, receiver, or transceiver; a conductive element electrically coupled to the EM transmitter, receiver, or transceiver; a lower signal conductor positioned coaxially around the conductive element, the lower signal conductor supporting the pressure housing and conductive element within the inner diameter of a drill collar and providing electrical connection between the conductive element and a section of the drill collar on one side of an insulated gap; and an upper signal conductor positioned coaxially around the conductive element, the upper conductor supporting the conductive element within the inner diameter of the drill collar and providing electrical connection between the conductive element and a section of the drill collar on the other side of the insulated gap.

**[0008]** This disclosure also provides for a tool for transmitting electromagnetic data telemetry from a downhole sensor during drilling operations. The tool may include a drill collar, the drill collar including a first and second tubular, the first and second tubulars formed from an electrically conductive material and coupled by an insulated gap; a pressure housing, the pressure housing including an EM transmitter, receiver, or transceiver; a conductive element electrically coupled to the EM transmitter, receiver, or transceiver; a lower hanger rigidly coupled to the first tubular, the lower hanger positioned coaxially around the conductive element, the lower hanger supporting the pressure housing and conductive element within the inner diameter of the first tubular and providing electrical connection between the conductive element and the first tubular; and an upper hanger rigidly coupled to the second tubular, the upper hanger positioned coaxially around the conductive element, the upper hanger supporting the conductive element within the inner diameter of the second tubular and providing electrical connection between the conductive element and the second tubular.

**[0009]** This disclosure also provides for a tool for transmitting electromagnetic data telemetry from a downhole sensor during drilling operations. The tool may include a drill collar, the drill collar including a first and second tubular, the first and second tubulars formed from an electrically conductive material and coupled by an insulated gap; a pressure housing, the pressure housing including an EM transmitter, receiver, or transceiver; a conductive element electrically coupled to the EM transmitter, receiver, or transceiver; a lower hanger rigidly coupled to the first tubular, the lower hanger positioned coaxially around the conductive element, the lower hanger supporting the pressure housing and conductive element within the inner diameter of the first tubular and providing electrical connection between the conductive element and the first tubular; and an upper signal conductor, the upper signal conductor positioned coaxially around the conductive element, the upper signal conductor providing electrical connection between the conductive element and the second tubular.

**[0010]** This disclosure also provides for a method for providing improved reliability of electromagnetic (EM) data telemetry to the well site surface from downhole EM sensors in a tool assembly during drilling of a well. The method may include providing a pressure housing, the pressure housing including an EM transmitter, receiver, or transceiver; electrically coupling a conductive element to the EM transmitter, receiver, or transceiver; and tensioning the conductive element between an upper hanger and a lower hanger, the upper hanger and lower hanger positioned within a drill collar, the drill collar including a first and second conductive tubular, the tubulars separated by an insulating gap.

#### BRIEF DESCRIPTION OF THE DRAWINGS

**[0011]** The present disclosure is best understood from the following detailed description when read with the accompanying figures. It is emphasized that, in accordance with the standard practice in the industry, various features are not drawn to scale. In fact, the dimensions of the various features may be arbitrarily increased or reduced for clarity of discussion.

**[0012]** FIGS. 1A-1C are partial cross sections of an EM MWD/LWD system consistent with at least one embodiment of the present disclosure.

**[0013]** FIG. 2 is a partial cross section of the EM MWD/LWD system of FIG. 1

**[0014]** FIG. 3 is a continuation of the partial cross section of FIG. 2.

**[0015]** FIG. 4 is a continuation of the partial cross section of FIG. 3.

**[0016]** FIG. 5 is a continuation of the partial cross section of FIG. 4.

**[0017]** FIG. 6 is a continuation of the partial cross section of FIG. 5.

**[0018]** FIG. 7 is a continuation of the partial cross section of FIG. 6.

#### DETAILED DESCRIPTION

**[0019]** It is to be understood that the following disclosure provides many different embodiments, or examples, for implementing different features of various embodiments. Specific examples of components and arrangements are described below to simplify the present disclosure. These are, of course, merely examples and are not intended to be limiting. In addition, the present disclosure may repeat reference numerals and/or letters in the various examples. This repetition is for the purpose of simplicity and clarity and does not in itself dictate a relationship between the various embodiments and/or configurations discussed.

**[0020]** Disclosed herein is a configuration of an EM MWD/LWD system which may improve communication reliability through more secure contact between the probe and the drill collar. Further, the configuration may improve reliability by increasing shock and vibration tolerance, and increasing electrical isolation between upper and lower units to avoid signal shorting and attenuation found in earlier derivations. Additionally, the disclosed configuration may be optimized for shipping and movement between a rig site and off-site maintenance and repair facilities to minimize rig downtime and allow for service and maintenance in more optimal and controlled conditions. The configuration may be utilized with multiple fluid drilling configurations, including but not limited to mud, air, and foam drilling.

**[0021]** In one embodiment, the MWD tool assembly is kept to the minimum length possible. The MWD tool has multiple positive electrical contacts both above and below the electrical isolation in a Gap Sub via electrical conduction springs and solid metal centralizers which may also be further sealed against drilling fluid flow by O-rings between the solid metal centralizers and the inside diameter (ID) of the drill collar. Openings through the metal centralizers allow fluid to flow past connection points without interfering with the electrical connection. Additionally, the MWD tool involves placing the components in either tension or compression to help ensure the system is rigid and resistant to movement during shock and vibration of the BHA with respect to the EM tool assembly. By adjusting the tension of the system, the natural frequency of the EM tool assembly can be adjusted to avoid common frequencies and harmonics found in drilling operations.

**[0022]** FIGS. 1A-1C depict an EM MWD system **101** consistent with at least one embodiment of the present disclosure installed in a collar assembly **102**. Here, collar assembly **102** is depicted as a four collar set including an upper hanger collar **103**, gap sub **105** (also called the upper to lower isolation), sensor collar **107**, and lower sub **109** (also called orientation collar). In at least one embodiment, all electronics of MWD tool **101** and specifically the EM Transmitter are installed in a pressure housing **113**. In some embodiments, pressure housing **113** may be approximately 3/4" in diameter, and approximately 5.4 feet in length. One having ordinary skill in the art with the benefit of this disclosure will understand that differing diameters and lengths may be utilized depending on the size, shape, and configuration of the EM transmitter. Although discussed herein as a transmitter, one having ordinary skill in the art with the benefit of this disclosure will understand that EM MWD system **101** could likewise be used to receive signals from the surface within the scope of this disclosure.

**[0023]** By selecting the OD and length of pressure housing **113**, pressure housing **113** may be of a sufficient stiffness to counteract the potential of pressure housing **113** contacting the wall of sensor collar **107** during a mechanical shock event. Additionally, higher stiffness may also increase the resonant frequency of EM MWD system **101**. When the resonant frequency is increased, the chances of causing EM MWD system **101** to oscillate at its natural frequency may be reduced, and the potential for extremely high levels of vibration may be lowered.

**[0024]** Pressure housing **113** is sealed both above and below the electronics with end caps (coil housing **115**, tail **117**) as shown in FIGS. 6 and 7 respectively. Tail **117** may include a flow diverter **119** to re-direct the drilling fluid from between pressure housing **113** and the ID of Sensor Collar **107** to the ID of lower sub **109**. Tail **117** may also include a lower signal conductor **121** coupled to lower sub **109**. FIG. 7 depicts lower signal conductor **121** as an external tapered thread for interfacing with an internal tapered thread of lower sub **109**. This connection constitutes one of two potential locations EM MWD system **101** is electrically connected to collar assembly **102** wall below gap sub **105** and the rest of the BHA (not shown) through this metal to metal mounting. Tail **117** may include rubber spacers **123** between the ID of sensor collar **107** and the OD of tail **117** to, for example, buffer EM MWD system **101** against shock.

**[0025]** Pressure housing **113**, as depicted in FIGS. 5, 6, also includes coil housing **115**. Coil housing **115** may in some

embodiments include a transformer coil (not shown) positioned between the transmitter of EM MWD system 101 and conductive element 139. Coil housing 115 may be connected to lower hanger 125. Lower hanger 125 may have an OD just under the ID of sensor collar 107. Lower hanger 125 and coil housing 115 are conductive and may be utilized to transfer an electrical signal from EM MWD system 101 to a second point on collar assembly 102. Lower hanger 125 may include seals 127, 129 between the OD of lower hanger 125 and the ID of sensor collar 107 to form a sealed portion 131 from drilling fluid present in collar assembly 102. Seals 127, 129 are depicted in FIG. 5 as O rings, but one having ordinary skill in the art with the benefit of this disclosure will understand that any suitable seal may be utilized within the scope of this disclosure.

[0026] In sealed portion 131, at least one toroidal contact spring 133 electrically couples the body of lower hanger 125 and sensor collar 107 in the absence of drilling fluid, foam, gas, or other invasive medium. In some embodiments, two such toroidal contact springs 133 are utilized, but one skilled in the art would appreciate that other numbers of contact springs may be utilized. A plurality of contact springs 133 may decrease the chance of contact loss. One skilled in the art would appreciate additional materials may be utilized to establish reliable electrical contact in the space between lower hanger 125 and sensor collar 107. For example, when a nonconductive fluid is utilized, fluid, or nonconductive contaminants could lodge between a conducting member and the collar wall in the absence of seals 127, 129, causing an electrical disconnection.

[0027] Lower hanger 125 may thus serve as a contact from EM MWD system 101 to the collars below gap sub 105. Isolating toroidal contact springs 133 from fluid invasion may help ensure the designed contact point stays consistent in electrical conductivity throughout the operation of EM MWD system 101 regardless of the drilling fluid utilized. Lower hanger 125 may also serve as a centralizer and support point for pressure housing 113. Sensor collar 107 is installed around lower hanger 125. Sensor collar 107 may be threaded onto lower sub 109 at the same location the tapered thread on tail 117 mates to lower sub 109 from the ID.

[0028] Coupling EM MWD system 101 to the collars below gap sub 105 at both lower hanger 125 and tail 117 may increase resilience of the electrical connection by providing two paths to make electrical contact. This redundancy may reduce the possibility of losing contact with the wall of the collars below gap sub 105 under severe shock and vibration.

[0029] Lower hanger 125 is coupled to a probe isolation component 135, which serves to electrically isolate pressure housing 113 and lower hanger 125 from antenna housing 137 on the other end of probe isolation component 135 utilizing an internal non-conductive material.

[0030] A sheathed wire (not shown) is run internally from coil housing 115 through probe isolation component 135 and connected to conductive element 139 located within antenna housing 137 (see FIG. 4), allowing the electronics to induce an electrical signal across probe isolation component 135 and eventually gap sub 105 via upper hanger 141 shown in FIG. 2. Conductive element 139 includes an electrical conductor 140 which is surrounded by a non-conductive sleeve 143. One having ordinary skill in the art with the benefit of this disclosure will understand that electrical conductor 140 may be any suitable conductive structure, including but not limited to a wire, rod, cable, etc. In some embodiments, sleeve 143 is

formed from fiberglass. Sleeve 143 prevents conductive fluids from allowing signal leakage between electrical conductor 140 and collar assembly 102. Sleeve 143 also eliminates the need to align probe isolation component 135 with gap sub 105 to avoid shorting or signal attenuation.

[0031] At one or more locations along sleeve 143, a centralizer 145 is used to support conductive element 139 and help minimize movement with respect to collar assembly 102. Centralizer 145 may be constructed from a hard, non-conductive material. In some embodiments, centralizer 145 is formed from fiberglass. In at least one embodiment, multiple centralizers 145 are positioned as close as possible to, for example, prevent vibration of conductive element 139, and provide adequate support for horizontal operations. Centralizers 145 may also be spaced enough to eliminate needless turbulence in the fluid flow which may add to wear on sleeve 143 and centralizers 145.

[0032] In some embodiments, centralizers 145 could be lengthened to the point that one or more run the length of conductive element 139, serving the function of both centralizer 145 and sleeve 143. In such a configuration, care would need to be taken to orient wings or protrusions 147 on centralizer 145 with respect to an abutting centralizer to avoid fluid turbulence or blockage.

[0033] In at least one embodiment, both centralizer 145 and sleeve 143 are sealed to solid conductor 140 of conductive element 139 with the use of O-rings or other sealing systems to further prevent exposure of large areas of conductor 140 to the invasive medium at high pressure. Ideally spacers and sleeves are also abutted in such a manner as to create an additional seal between the neighboring spacers/sleeves.

[0034] By creating a non-conducting sleeve 143 around conductive element 139, the system can be assembled within varying lengths of collars without the need to adjust the placement of the probe isolation components 135. Without non-conducting sleeve 143, if the probe isolation components 135 are not aligned with gap 149 of gap sub 105, the annular space between conductive element 139 OD and collar assembly 102 ID could carry conductive drilling fluid which could shunt the EM signal across the fluid. Any shunting may, for example, reduce the effectiveness of the system by applying additional load to the transmitting system. Furthermore, any signal shunted across the conductive fluid would not aid in transmitting the EM signal from down hole to surface.

[0035] In addition, the use of a hard centralizer 145 compared with current technology's use of rubber or spring loaded metal may increase the rigidity of conductive element 139 by rigidly coupling it to the surrounding collar assembly 102. Thus, shock resulting from hard impacts may be reduced, and vibration may be dampened. Reduction in shock and vibration to pressure housing 113 and conductive element 139 may lead to improved reliability.

[0036] Gap Sub 105 is threaded onto sensor collar 107 around conductive element 139. In some embodiments, compression stack 151 may be positioned within sensor collar 107, such that compression stack 151 is compressed between the pin of gap sub 105 and the top of lower hanger 125 as gap sub 105 is screwed into sensor collar 107 (FIG. 5). Compression stack 151 may include a hard rubber body positioned to, for example, dampen shock and vibration to EM MWD system 101 while retaining it within sensor collar 107.

[0037] In some embodiments, as depicted in FIG. 2, upper hanger collar 103 is coupled to gap sub 105. Upper hanger 153 is installed in upper hanger collar 103, and may be

secured in place with hanger retention nut **155** to the ID of upper hanger collar **103**. Upper hanger **153** has a center hole (not shown) to accommodate conductive element **139**, which may traverse through upper hanger **153**. Conductive element **139** may be secured to upper hanger **153** by conductive element tensioning nut **157**. Conductive element tensioning nut **157** may serve to tension conductor **140** by pulling it against lower hanger **125**. At the same time, sleeve **143** is put in compression as it is pinched between upper and lower hangers **131**, **153**.

**[0038]** Applying tension on conductor **140** may add to the stiffness of conductive element **139**. Increased tension may also increase the fundamental harmonic frequency of conductive element **139**, thereby reducing the chance for high levels of vibration caused by resonance. Compression of sleeve **143** may amplify this effect.

**[0039]** Upper hanger **153**, similarly to lower hanger **125**, may also utilize two seals **159**, **161** to seal a section **163** of the OD of upper hanger **153** from the drilling fluid, or other invasive medium. In some embodiments, at least one toroidal contact spring **165** is positioned to electrically couple upper hanger **153** to upper hanger collar **103**. As with lower hanger **125**, making electrical contact in an uncontaminated location ensures continuous conduction across the contact in the presence of drilling fluid within the collar.

**[0040]** In at least one embodiment, upper hanger **153** is installed directly into Gap Sub **105**. The length of conductive element **139** may be less than 36 inches in length. Conductive element **139** may be supported at the midpoint, whereby conductive element **139** is supported at approximate 18 inch increments with a hard non-conductive centralizer **145**. The drawings included in this disclosure illustrate an embodiment which utilizes an upper hanger collar **103** to allow testing of various gap subs without modification of the gap sub body itself. One having ordinary skill in the art with the benefit of this disclosure will understand that any length conductive element may be substituted without deviating from the scope of this disclosure, and that stabilizer positioning may be carried as previously discussed and otherwise.

**[0041]** In at least one other embodiment, conductive element **139** is not rigidly coupled to upper hanger collar **103** by an upper hanger. Instead, conductive element **139** is electrically coupled to upper hanger collar **103** by a traditional connection such as, for example and without limitation, a bow spring, wire, or bolt. Conductive element **139** is thus held rigidly to collar assembly **102** by lower hanger **125**. In certain embodiments, conductive element **139** may be held in tension by compressing sleeve **143**.

**[0042]** Due to the nature of this assembly, it may be desirable that EM MWD system **101** be assembled in a shop as opposed to the rig floor. For example, excessive rig down time may not be required while the system is installed in the collar on the rig floor, since EM MWD system **101** may be inserted as a complete unit into the bottom hole assembly as it is made up on the rig floor. Additionally, the shop assembly process may be easier to accomplish with better quality control than is possible using the rig floor assembly process.

**[0043]** The diagrams provided are in accordance with exemplary embodiments of the disclosure, and are provided as examples. They should not be construed to limit other embodiments within the scope of the disclosure. For instance, the size of certain sections should not be taken as absolutes with respect to other elements. Additional element may be added or subtracted from the configuration illustrated. Fur-

ther some elements may vary in count, orientation, or position within the scope of the disclosure. Further, plurality of elements rendered as separate elements may be joined into single elements, and elements illustrated individually may be divided into a plurality of sub-elements. Further yet, specific numerical data values (such as specific quantities, numbers, categories, etc.) or other specific information should be interpreted as illustrative for discussing exemplary embodiments. Such specific information is not provided to limit the disclosure.

**[0044]** The diagrams in accordance with exemplary embodiments of the present disclosure are provided as examples and should not be construed to limit other embodiments within the scope of the disclosure. For instance, heights, widths, and thicknesses may not be to scale and should not be construed to limit the disclosure to the particular proportions illustrated. Additionally some elements illustrated in the singularity may actually be implemented in a plurality. Further, some element illustrated in the plurality could actually vary in count. Further, some elements illustrated in one form could actually vary in detail. Further yet, specific numerical data values (such as specific quantities, numbers, categories, etc.) or other specific information should be interpreted as illustrative for discussing exemplary embodiments. Such specific information is not provided to limit the disclosure.

**[0045]** Multiple figures have been provided for many pieces, the views, sizes, and angles of the illustrations may vary, such variance should not be construed in a manner that is would limit the disclosure. Where multiple views, illustrations, photographs, renderings, or drawings have been provided of a single piece, any inconsistencies should be interpreted as different embodiments of the disclosure.

**[0046]** The above discussion is meant to be illustrative of the principles and various embodiments of the present disclosure. Numerous variations and modifications will become apparent to those skilled in the art once the above disclosure is fully appreciated. It is intended that the following claims be interpreted to embrace all such variations and modifications.

1. A tool for transmitting electromagnetic data telemetry from a downhole sensor during drilling operations comprising:

- a pressure housing, the pressure housing including an EM transmitter, receiver, or transceiver;
- a conductive element electrically coupled to the EM transmitter, receiver, or transceiver;
- a lower signal conductor positioned coaxially around the conductive element, the lower signal conductor supporting the pressure housing and conductive element within the inner diameter of a drill collar and providing electrical connection between the conductive element and a section of the drill collar on one side of an insulated gap; and
- an upper signal conductor positioned coaxially around the conductive element, the upper conductor supporting the conductive element within the inner diameter of the drill collar and providing electrical connection between the conductive element and a section of the drill collar on the other side of the insulated gap.

2. The tool of claim 1 wherein the conductive element is surrounded by one or more nonconductive sleeves.

3. The tool of claim 1 wherein the conductive element is supported along its length by one or more centralizers.

4. The tool of claim 3 wherein the centralizers are formed from a rigid material.

5. The tool of claim 3, wherein the conductive element is supported every 18 inches along its length.

6. The tool of claim 2 wherein the non-conductive sleeve is sealed at the ends against the conductive element to prevent contaminants entering between the sleeve and the conductive element.

7. The tool of claim 3 wherein the centralizer is sealed at the ends against the conductive element to prevent contaminants entering between the centralizer and the conductive element.

8. The tool of claim 1 wherein the upper and lower conductors are rigid cylindrical conductors with a plurality of through openings allowing fluid passage through the drill collar around the transmission assembly.

9. The tool of claim 1 wherein the length of the conductive element is less than 36 inches in length.

10. The tool of claim 1 wherein the upper and lower conductors are fixed at specific distances within the drill collar, and at least a portion of the conductive element is tensioned between the upper and lower signal conductors within the drill collar.

11. The tool of claim 2 wherein the upper and lower conductors are fixed at specific distances within the drill collar, and a portion of the nonconductive sleeve is compressed between the upper and lower conductors within the drill collar.

12. The tool of claim 10, wherein the upper signal conductor and lower signal conductor comprise upper and lower hangers positioned to transfer tension from the conductive element into the drill collar.

13. The tool of claim 10, wherein the upper and lower signal conductors further comprise toroidal contact springs to electrically couple the transmission assembly and the drill collar.

14. The tool of claim 1 wherein the electrical connections between the signal conductors and the drill collar comprise one or more toroidal springs seated around the outer diameter of the signal conductor and compressed against the inner diameter of the drill collar.

15. The tool of claim 14 wherein the signal conductor further comprises one or more seals seated around the outer diameter of the signal conductor and compressed against the inner diameter of the drill collar, said seals positioned nearer the end of the signal conductor than the toroidal springs.

16. A tool for transmitting electromagnetic data telemetry from a downhole sensor during drilling operations comprising;

- a drill collar, the drill collar including a first and second tubular, the first and second tubulars formed from an electrically conductive material and coupled by an insulated gap;
- a pressure housing, the pressure housing including an EM transmitter, receiver, or transceiver;
- a conductive element electrically coupled to the EM transmitter, receiver, or transceiver;
- a lower hanger rigidly coupled to the first tubular, the lower hanger positioned coaxially around the conductive element, the lower hanger supporting the pressure housing and conductive element within the inner diameter of the first tubular and providing electrical connection between the conductive element and the first tubular; and
- an upper hanger rigidly coupled to the second tubular, the upper hanger positioned coaxially around the conduc-

tive element, the upper hanger supporting the conductive element within the inner diameter of the second tubular and providing electrical connection between the conductive element and the second tubular.

17. The tool of claim 16, wherein the conductive element is tensioned between the upper and lower hangers.

18. The tool of claim 17, further comprising an insulating sheath positioned around the conductive element, the insulating sheath extending between the upper and lower hanger so that the upper and lower hanger exert a compressive force on the insulating sheath as the conductive element is tensioned.

19. The tool of claim 16, wherein the upper and lower hangers further comprise toroidal contact springs to electrically couple the transmission assembly and the drill collar.

20. The tool of claim 16 wherein the conductive element is supported along its length by one or more centralizers.

21. The tool of claim 20 wherein the centralizers are formed from a rigid material.

22. The tool of claim 20 wherein the centralizer is sealed at the ends against the conductive element to prevent contaminants entering between the centralizer and the conductive element.

23. The tool of claim 18, wherein the insulating sheath is sealed at the ends against the conductive element to prevent contaminants entering between the sheath and the conductive element.

24. The tool of claim 16 wherein the upper and lower hangers include a plurality of through openings allowing fluid passage through the drill collar around conductive element.

25. A tool for transmitting electromagnetic data telemetry from a downhole sensor during drilling operations comprising;

- a drill collar, the drill collar including a first and second tubular, the first and second tubulars formed from an electrically conductive material and coupled by an insulated gap;
- a pressure housing, the pressure housing including an EM transmitter, receiver, or transceiver;
- a conductive element electrically coupled to the EM transmitter, receiver, or transceiver;
- a lower hanger rigidly coupled to the first tubular, the lower hanger positioned coaxially around the conductive element, the lower hanger supporting the pressure housing and conductive element within the inner diameter of the first tubular and providing electrical connection between the conductive element and the first tubular; and
- an upper signal conductor, the upper signal conductor positioned coaxially around the conductive element, the upper signal conductor providing electrical connection between the conductive element and the second tubular.

26. The tool of claim 25, further comprising an insulating sheath positioned around the conductive element, the insulating sheath extending between the upper signal conductor and the lower hanger, the insulating sheath being under compressive load between the upper signal conductor and the lower hanger so that the conductive element is under tension.

27. The tool of claim 25, wherein the lower hanger further comprises a toroidal contact spring to electrically couple the transmission assembly and the drill collar.

28. The tool of claim 25 wherein the conductive element is supported along its length by one or more centralizers.

29. The tool of claim 28 wherein the centralizers are formed from a rigid material.

**30.** The tool of claim **28** wherein the centralizer is sealed at the ends against the conductive element to prevent contaminants entering between the centralizer and the conductive element.

**31.** The tool of claim **25**, wherein the insulating sheath is sealed at the ends against the conductive element to prevent contaminants entering between the sheath and the conductive element.

**32.** The tool of claim **25**, wherein the upper signal conductor comprises at least one of a bow spring, wire, or bolt.

**33.** A method for providing improved reliability of electromagnetic (EM) data telemetry to the well site surface from downhole EM sensors in a tool assembly during drilling of a well, the method comprising:

providing a pressure housing, the pressure housing including an EM transmitter, receiver, or transceiver;  
electrically coupling a conductive element to the EM transmitter, receiver, or transceiver;

tensioning the conductive element between an upper hanger and a lower hanger, the upper hanger and lower hanger positioned within a drill collar, the drill collar including a first and second conductive tubular, the tubulars separated by an insulating gap.

**34.** The method of claim **33**, further comprising: selecting the diameter, length, and tension of the conductive element so that the resonant frequency is increased.

**35.** The method of claim **33**, wherein the upper and lower signal conductors further comprise toroidal contact springs to electrically couple the transmission assembly and the drill collar.

**36.** The method of claim **33**, wherein the tool is assembled prior to delivery to the rig floor at the well site.

**37.** The method of claim **33**, wherein the tool is shipped to the well site in a substantially assembled configuration.

\* \* \* \* \*