

(12) **UK Patent Application** (19) **GB** (11) **2 358 990** (13) **A**

(43) Date of A Publication **08.08.2001**

(21) Application No **0022550.8**
 (22) Date of Filing **14.09.2000**
 (30) Priority Data
 (31) **09395452** (32) **14.09.1999** (33) **US**

(71) Applicant(s)
Motorola Inc
(Incorporated in USA - Delaware)
1303 East Algonquin Road, Schaumburg,
Illinois 60196, United States of America

(72) Inventor(s)
John Freese
Michael L Charlier
Jenifer Fahey
Eric Le Roy Krenz
Rachid Alameh
Louis J Vannatta

(51) INT CL⁷
H04B 1/38

(52) UK CL (Edition S)
H4L LESF

(56) Documents Cited
WO 96/39752 A1 JP 080084172 A JP 040343532 A
US 5991637 A US 5890071 A

(58) Field of Search
 UK CL (Edition S) **H4L LECY LEP LESF**
 INT CL⁷ **H04B 1/38 , H04Q 7/32**
Online Databases: WPI, EPODOC, JAPIO

(74) Agent and/or Address for Service
Motorola Limited
European Intellectual Property Department, Midpoint,
Alencon Link, BASINGSTOKE, Hampshire, RG21 7PL,
United Kingdom

(54) Abstract Title
Combined mobile telephone and broadcast radio receiver

(57) A dual purpose hand-held wireless communication device comprises an integrated cellular telephone and AM/FM radio receiver. An audio processing block selectively couples either the AM/FM receiver or the cellular receiver to the audio output. The device may have separate or a shared antenna for the receivers. Various antennas and impedance matching circuits are described. When listening to the AM/FM radio an audio signal alerts the user of an incoming cellular call. The incoming call may be looked for by periodically tuning away from the audio source and looking for a barker signal. Audio filtering and smoothing makes the interruption less perceptible. A caller put on hold may listen to the AM/FM radio. The communication device may comprise an integrated pager and AM/FM radio receiver.

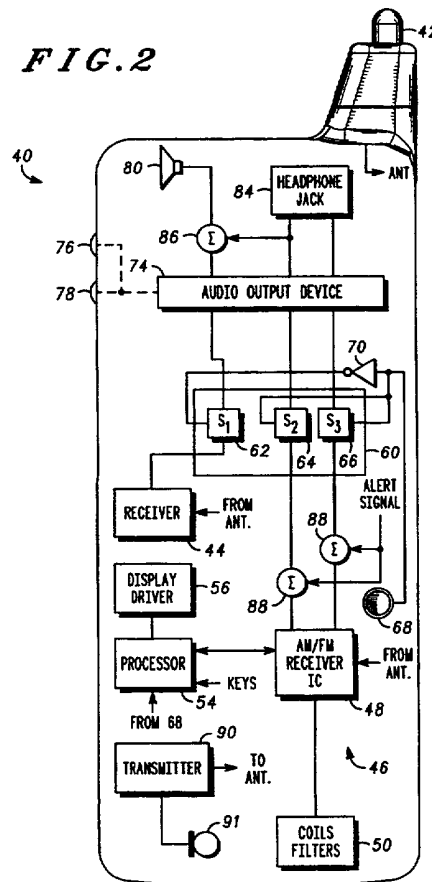

GB 2 358 990 A

At least one drawing originally filed was informal and the print reproduced here is taken from a later filed formal copy. This print takes account of replacement documents submitted after the date of filing to enable the application to comply with the formal requirements of the Patents Rules 1995. This print incorporates corrections made under Section 117(1) of the Patents Act 1977.

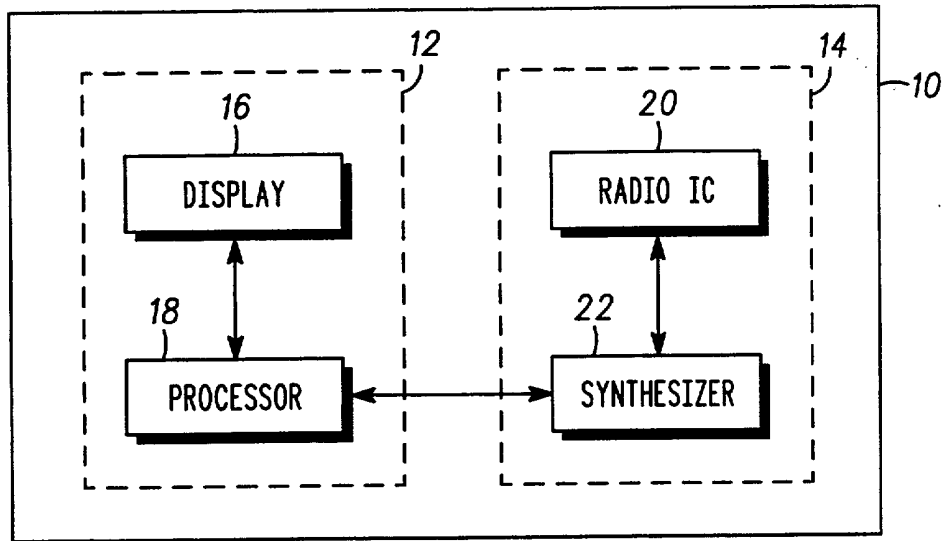

FIG. 1

FIG. 4

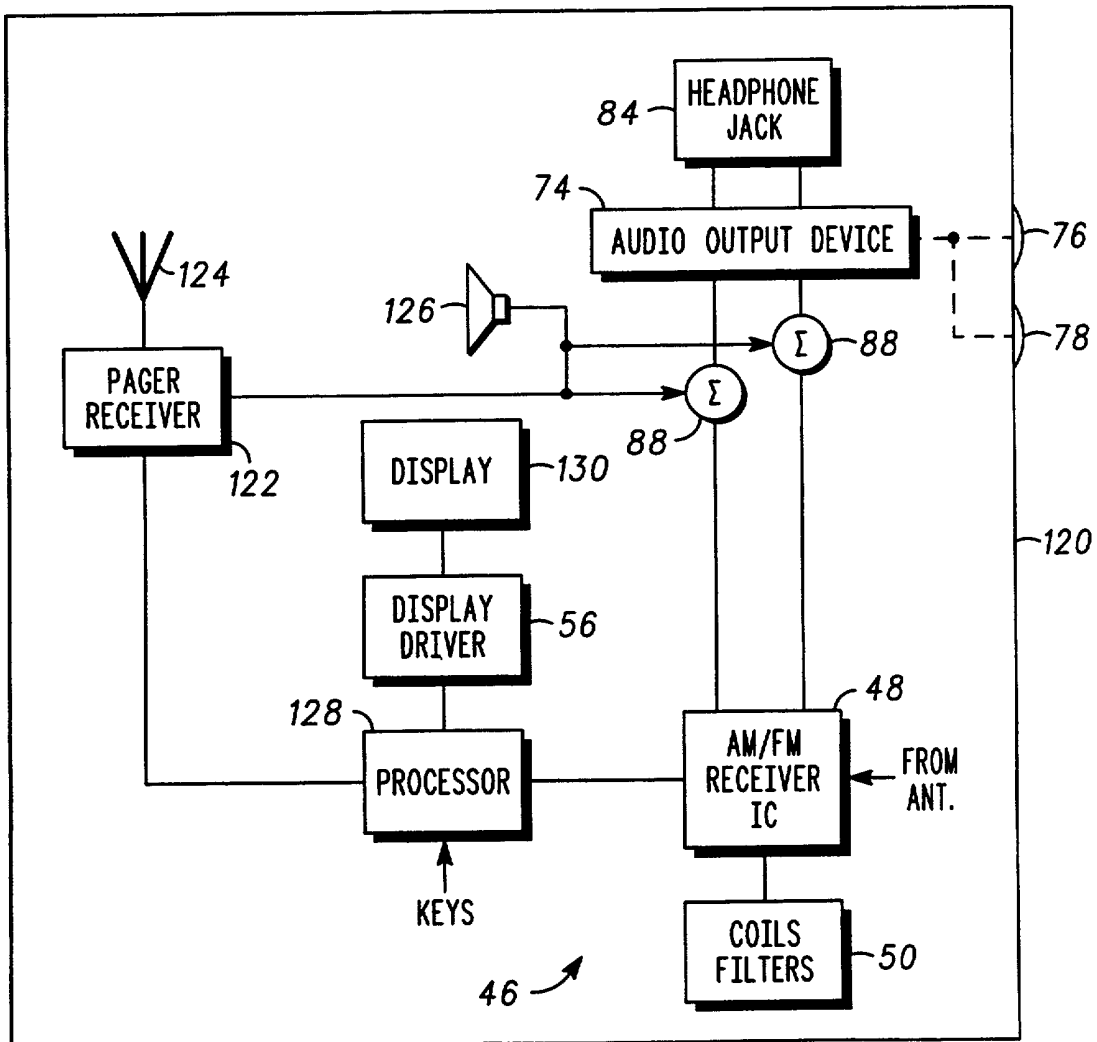

FIG. 2

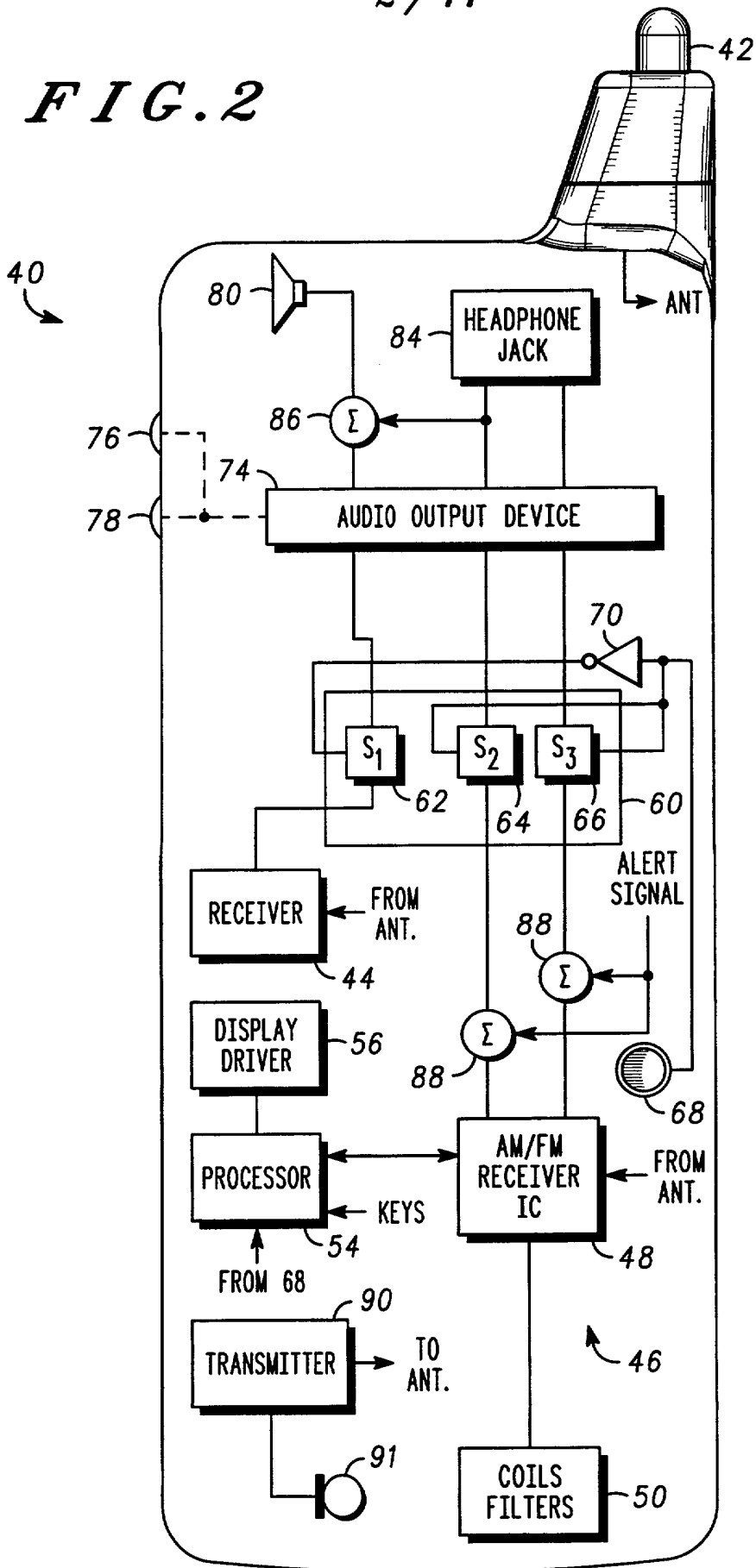

FIG. 3

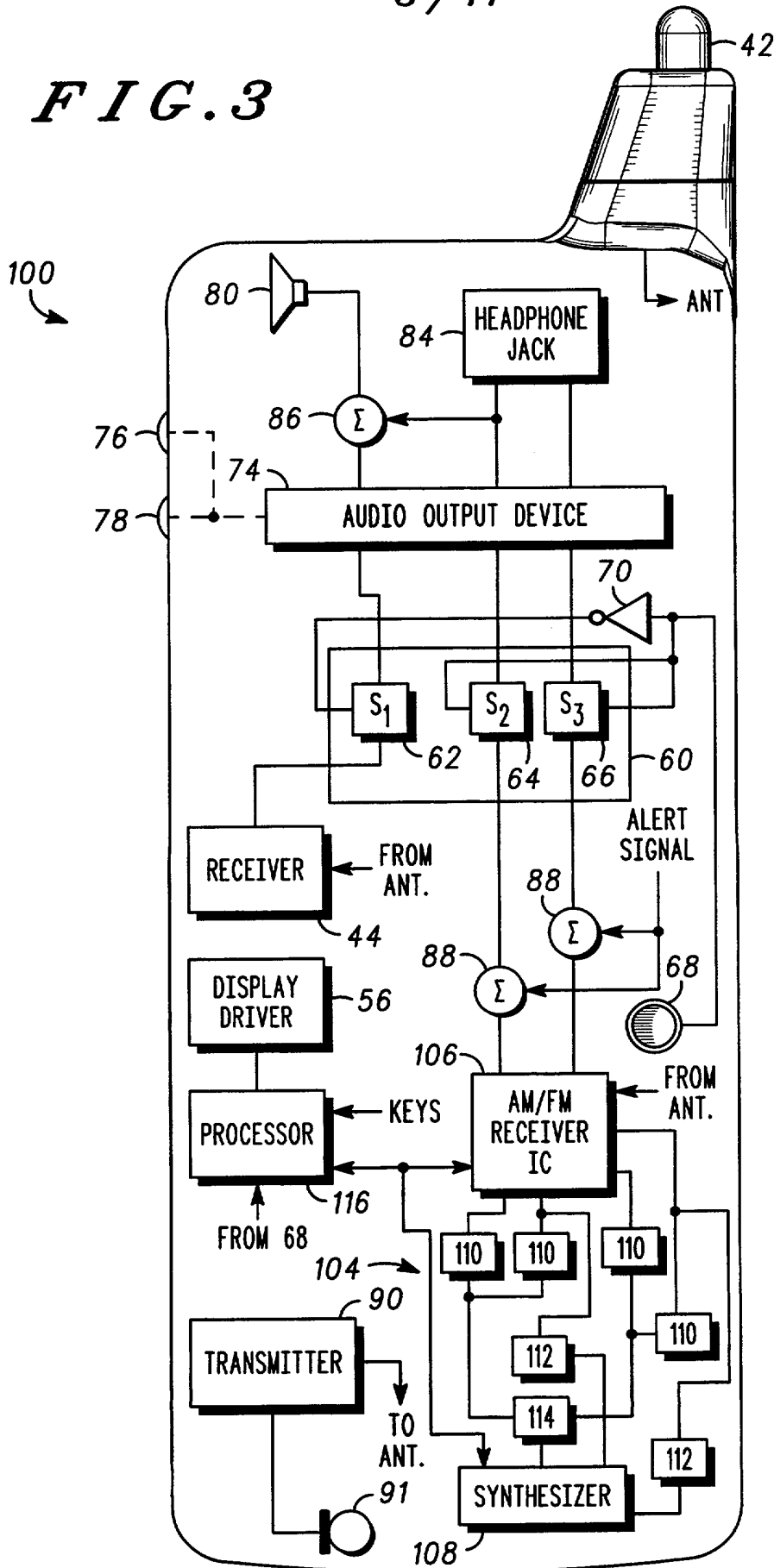
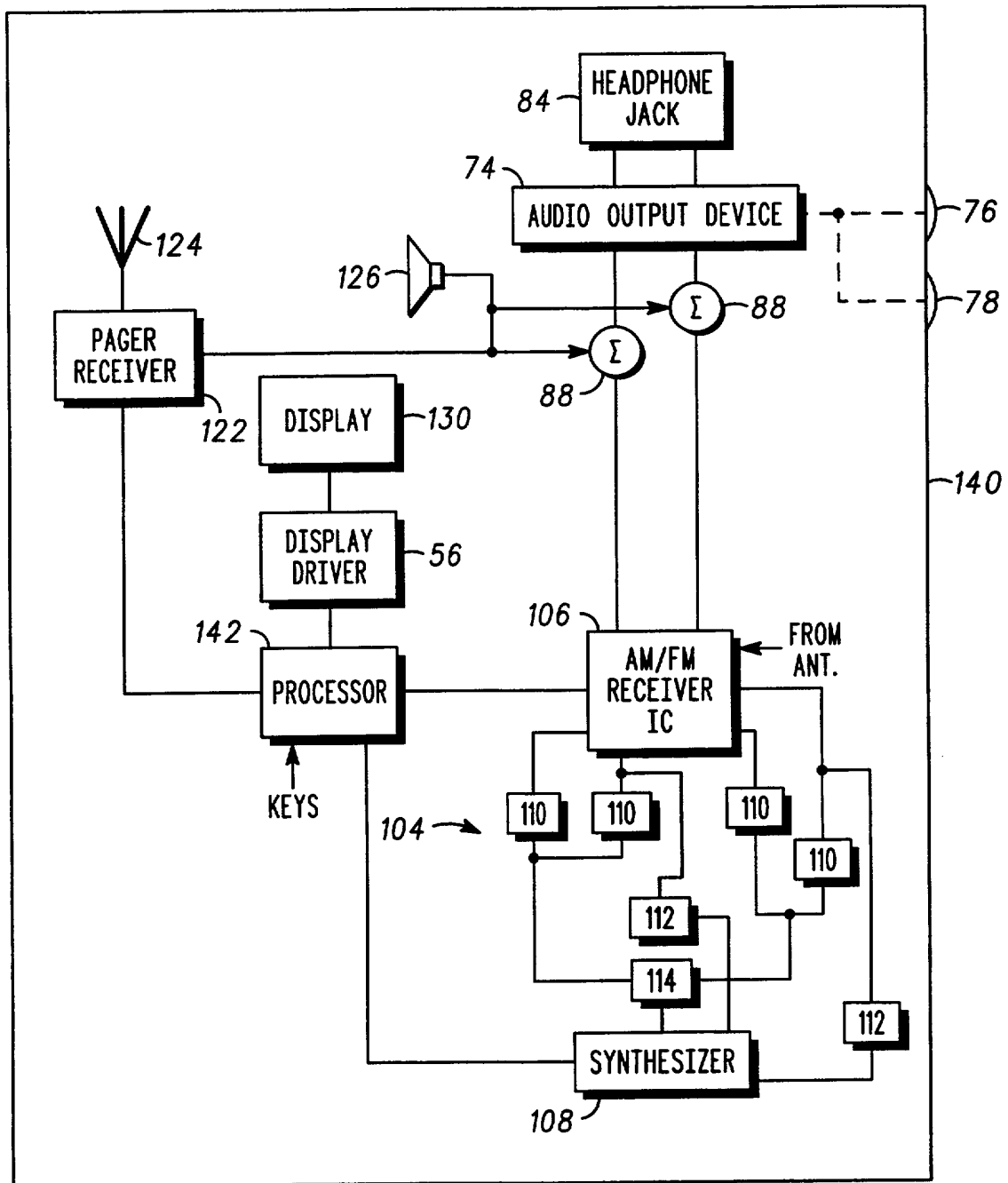

FIG. 5



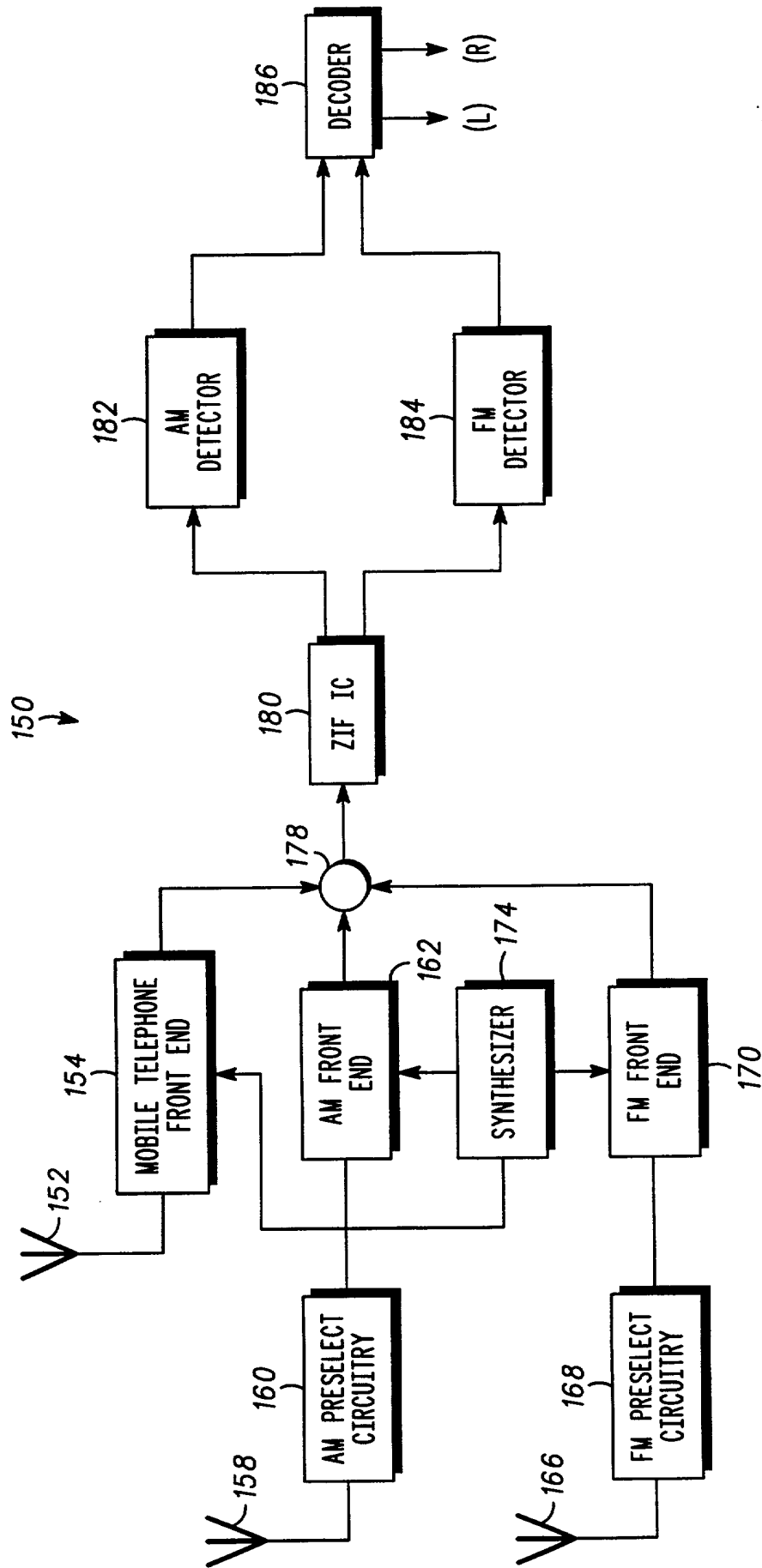

FIG. 6

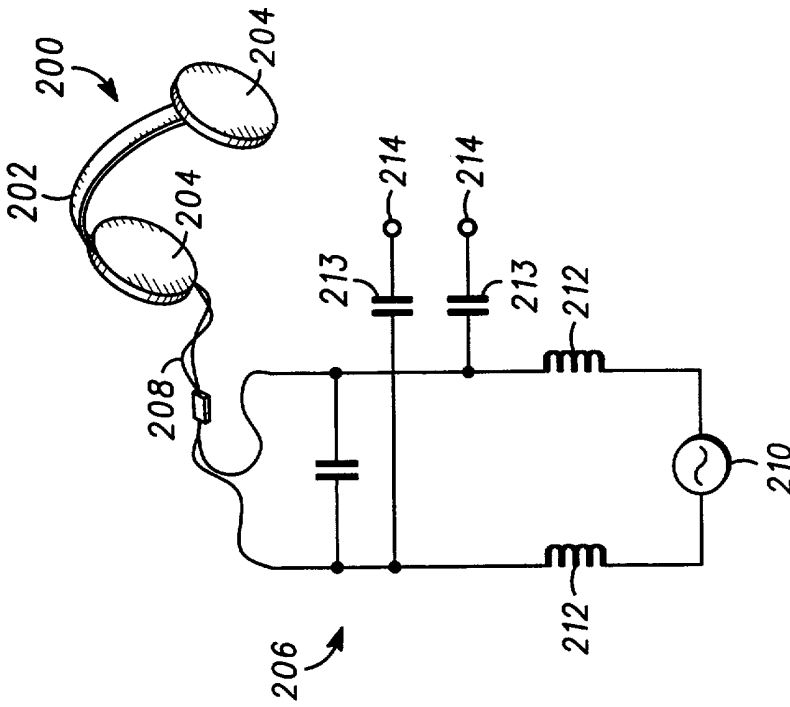

FIG. 7

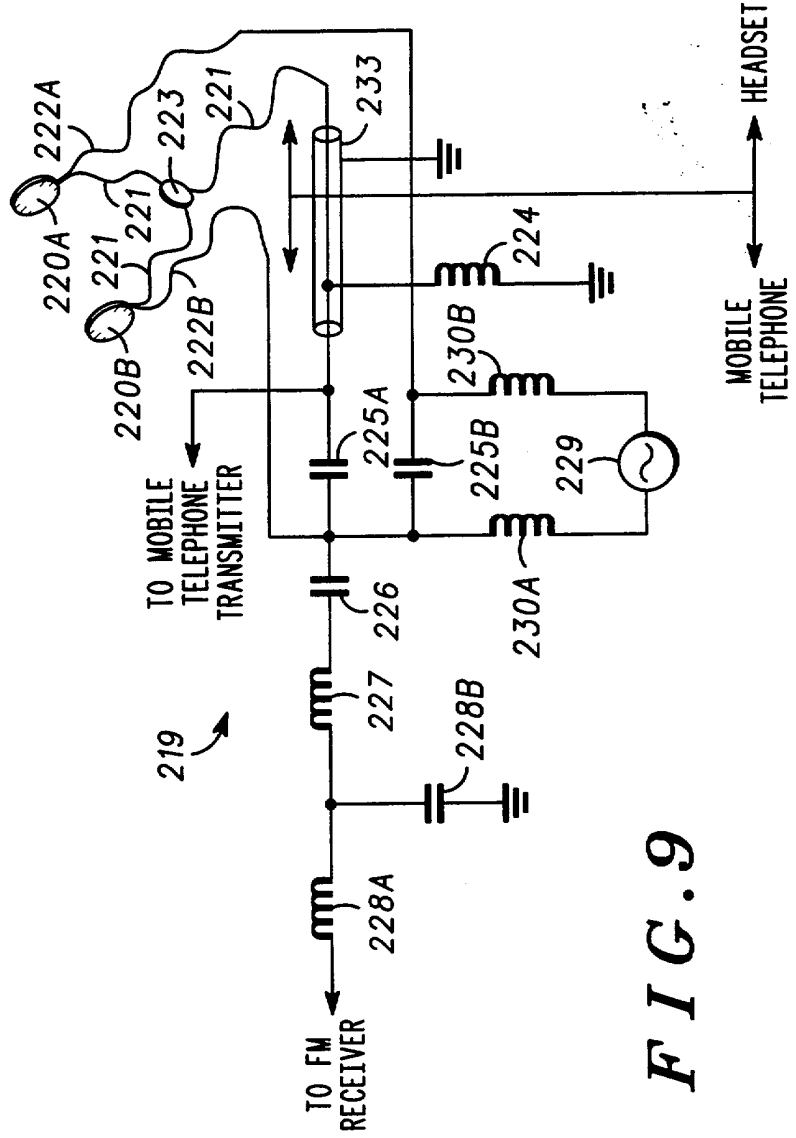

FIG. 9

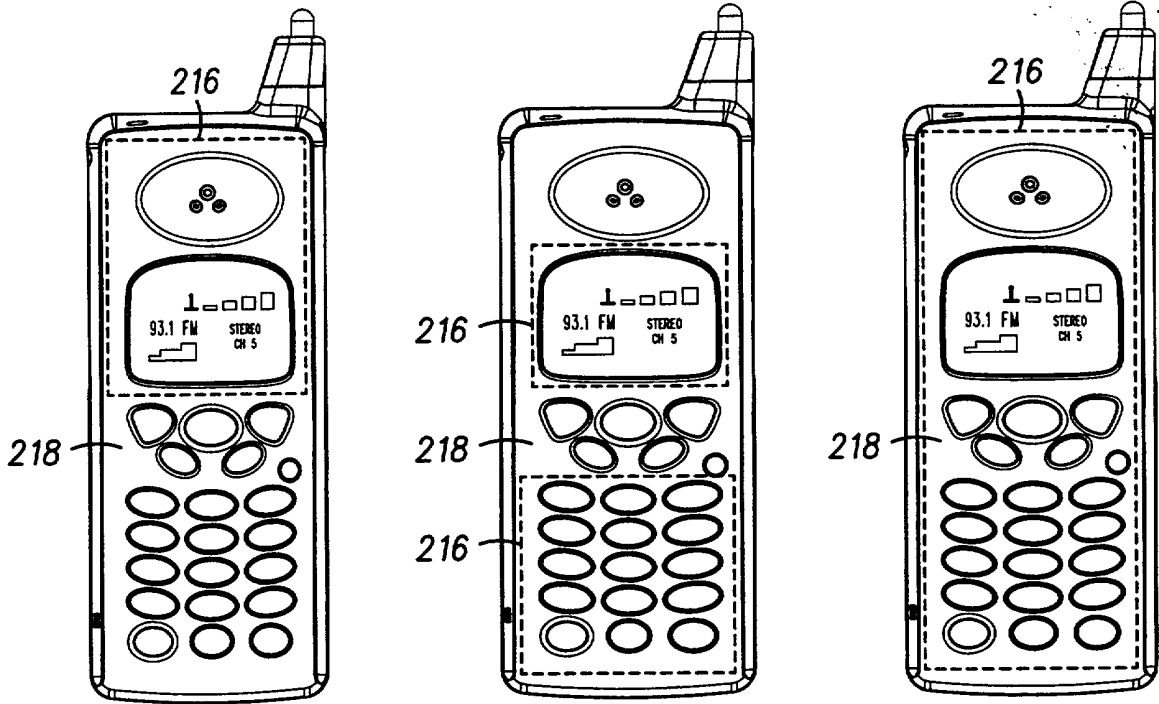

FIG. 8A FIG. 8B FIG. 8C

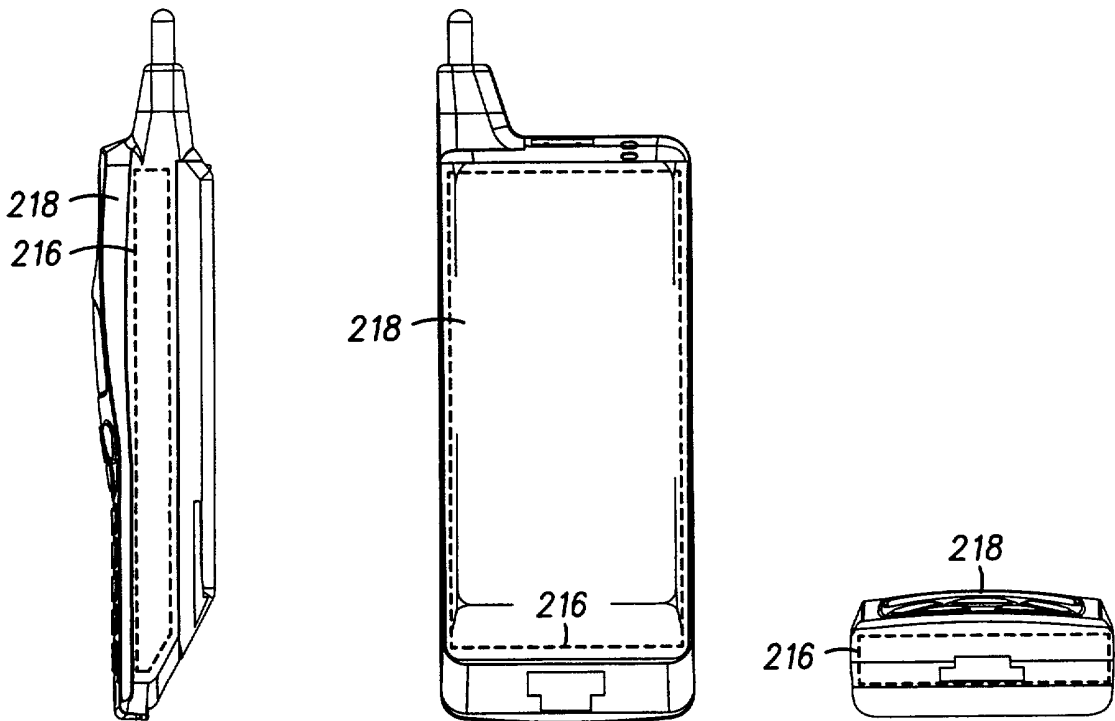

FIG. 8D FIG. 8E FIG. 8F

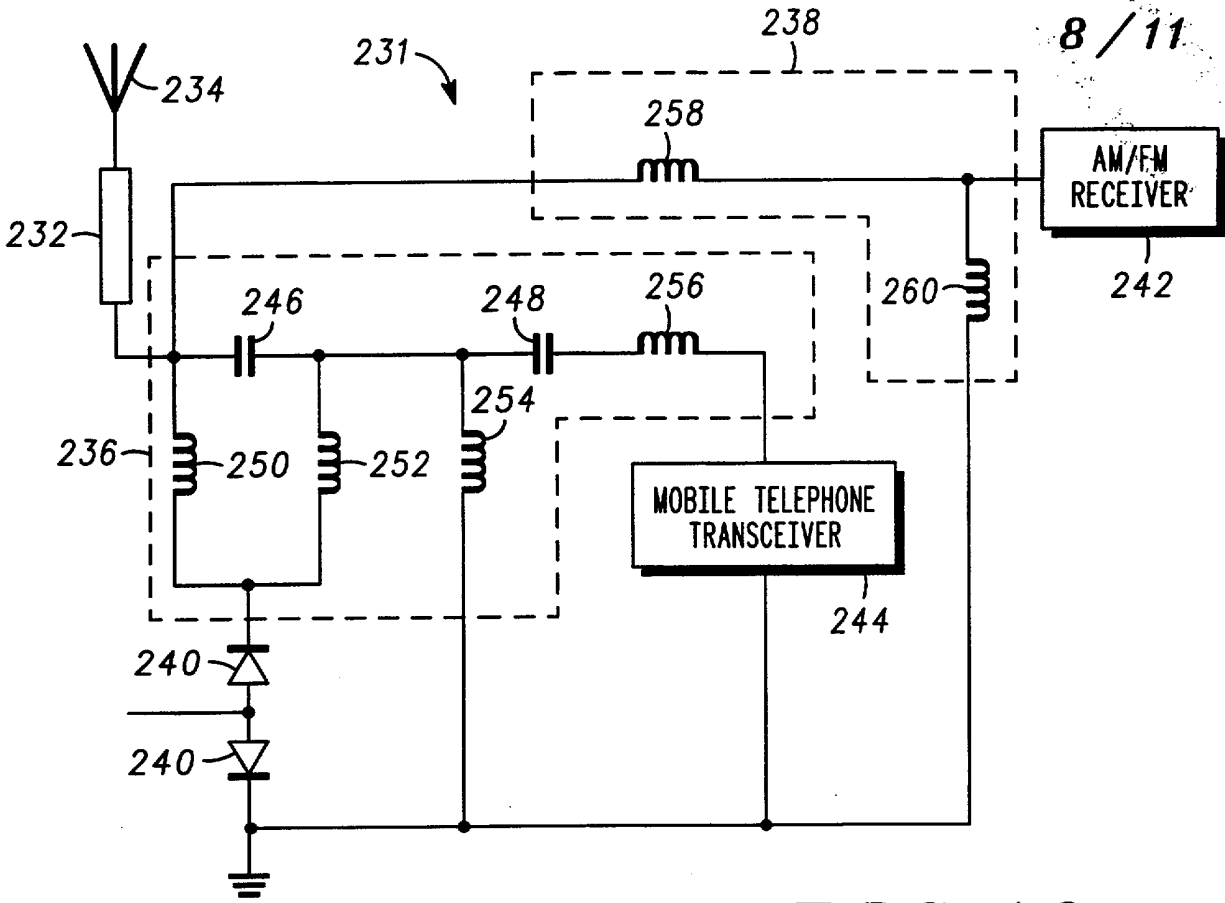

FIG. 10

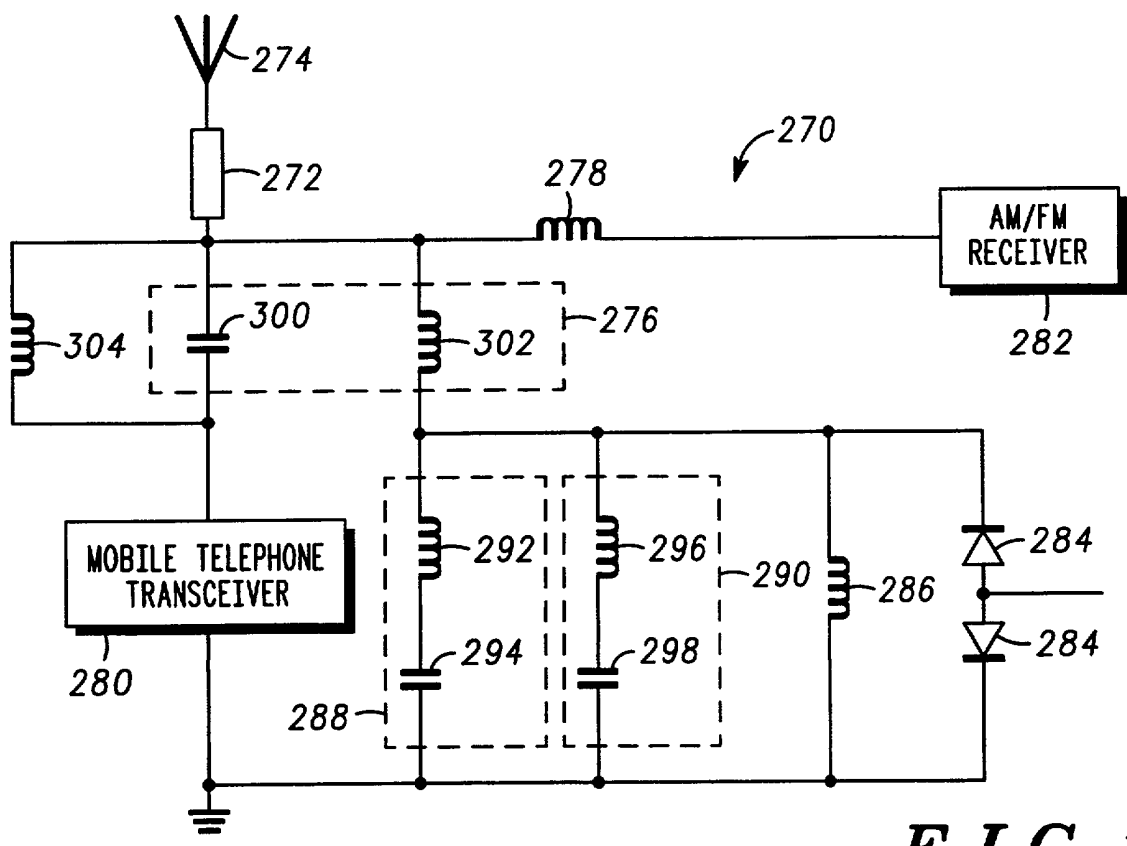

FIG. 11

FIG. 12

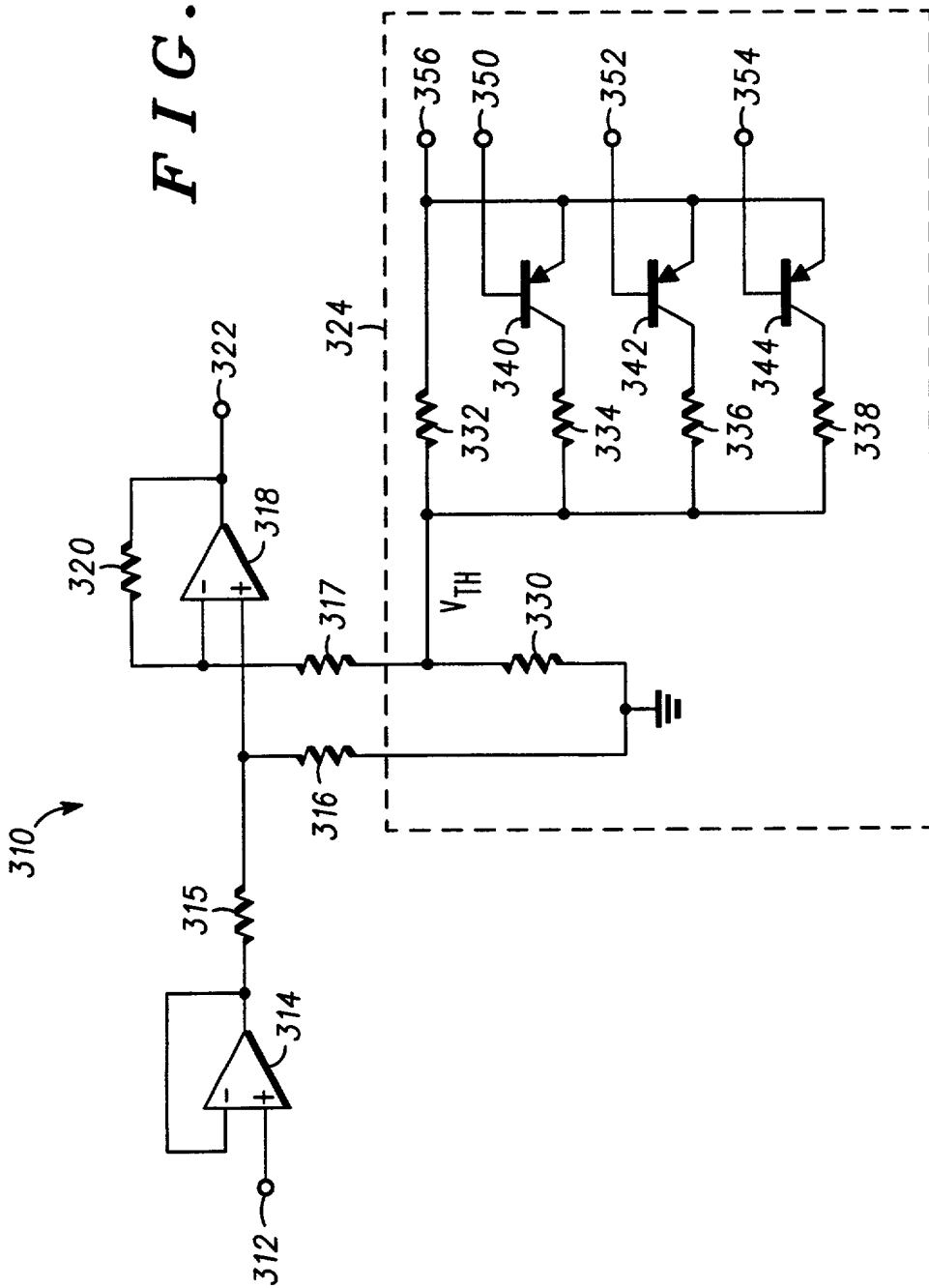

FIG. 13

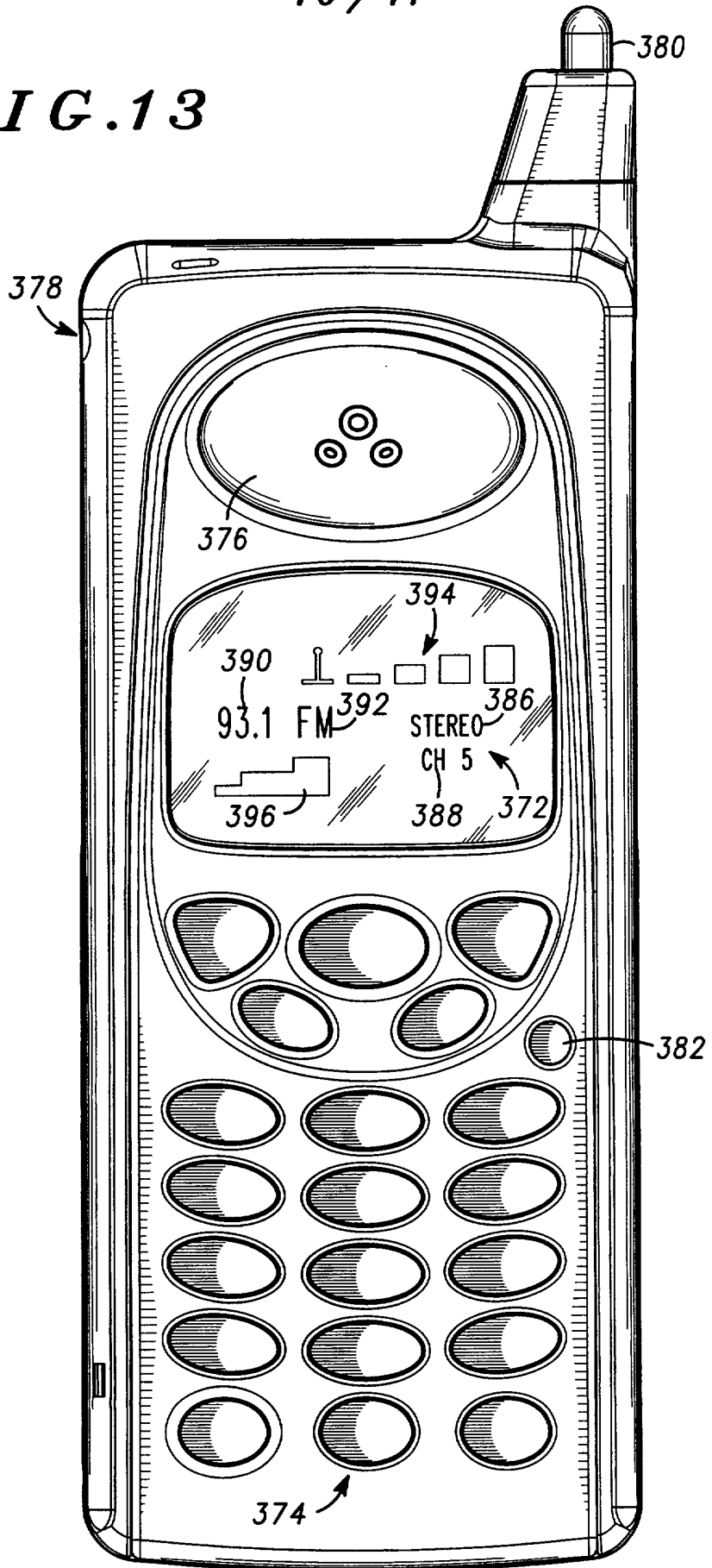
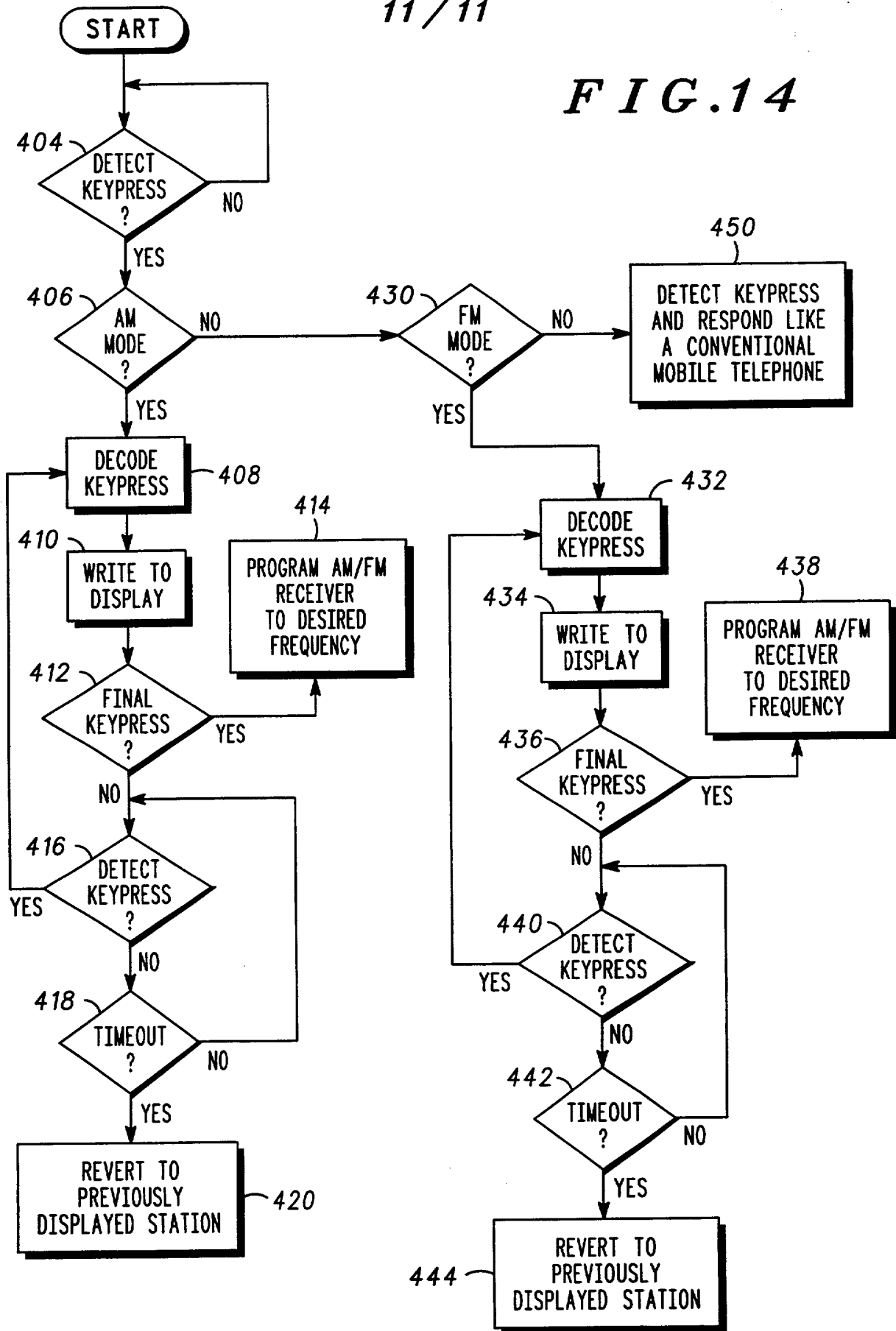

FIG. 14



A DUAL PURPOSE, HAND-HELD COMMUNICATION DEVICE

FIELD OF THE INVENTION

5 The present invention relates in general to an apparatus for receiving two different forms of communication signals and, in particular, to a device for receiving AM/FM radio signals and for receiving communication information such as mobile telephone information or paging information.

BACKGROUND OF THE INVENTION

10 Presently there are numerous personal, wearable electronic devices that are available on the consumer market. These devices include personal AM/FM radios having headphones and personal communication devices such as mobile telephones (e.g., analog and digital cellular telephones, global system for mobile communications (GSM) telephones, and personal communications system (PCS) telephones) and pagers (e.g., one-way and
15 two-way pagers).

Although these devices provide their attendant functions, consumers traveling by foot, by bus, by train or by bike must often carry multiple devices to get the basic communication functionality of listening to AM/FM radio and being able to receive communications via a personal communication device.
20 For example, a person traveling by train may wish to listen to his or her personal AM/FM radio, while still being available to receive communications via a mobile telephone. However, while listening to his or her personal AM/FM radio, a consumer may not hear a beeping pager or a ringing mobile telephone and, therefore, may miss an incoming communication. Although
25 many personal communication devices have a "vibrate mode," this mode mandates that the consumer have these devices on their person to feel the vibration; simply carrying a mobile telephone or a pager in a briefcase or a purse will not do because the consumer will not feel the device vibrate when there is an incoming communication. Although they are small, carrying



multiple personal, wearable electronic devices on one's person is burdensome.

Even if a consumer were able to hear a ringing or beeping personal communication device while they were listening to their personal AM/FM radio, considerable device manipulation is required to turn off or mute the AM/FM radio and to activate the personal communication device to receive an incoming communication.

In sum, carrying a personal AM/FM radio and a personal communication device is cumbersome. While a consumer uses the personal AM/FM radio he or she may not even be aware of an incoming communication to a personal communication device because he or she may not hear a ringer or feel a vibrator. Additionally, even if the consumer is aware of an incoming communication, he or she must quickly manipulate the personal AM/FM radio and the personal communication device to receive the communication.

BRIEF DESCRIPTION OF THE DRAWINGS

FIG. 1 is a block diagram that illustrates a dual purpose communication device having a stand-alone AM/FM receiver.

FIG. 2 is a block diagram illustrating a first embodiment of a mobile telephone having a stand-alone AM/FM receiver in accordance with the teachings of the present invention.

FIG. 3 is a block diagram illustrating a second embodiment of a mobile telephone having a stand-alone AM/FM receiver in accordance with the teachings of the present invention.

FIG. 4 is a block diagram illustrating a first embodiment of a pager having a stand-alone AM/FM receiver in accordance with the teachings of the present invention.

FIG. 5 is a block diagram illustrating a second embodiment of a pager having a stand-alone AM/FM receiver in accordance with the teachings of the present invention.

FIG. 6 is a block diagram illustrating a hardware implementation of an integrated AM/FM receiver combined with existing personal communication device hardware in accordance with the teachings of the present invention.

FIG. 7 is a schematic diagram of an embodiment of an AM antenna integrated into a headset.

FIGS. 8a-8f illustrate various arrangements for an AM antenna within a dual purpose communication device.

FIG. 9 is a schematic diagram of an embodiment of an FM antenna integrated into a headset.

FIG. 10 is a schematic representation of a first embodiment of a matching circuit used to match a mobile telephone antenna to mobile telephone circuitry and to an AM/FM receiver in accordance with the teachings of the present invention.

FIG. 11 is a schematic representation of a second embodiment of a matching circuit used to match a mobile telephone antenna to mobile telephone circuitry and to an AM/FM receiver in accordance with the teachings of the present invention.

FIG. 12 is a schematic representation of a voltage extender circuit in accordance with the teachings of the present invention.

FIG. 13 is a front view of a dual purpose communication device embodied in a mobile telephone having an AM/FM receiver in accordance with the present invention.

FIG. 14 is a flow diagram that illustrates how the dual purpose communication device processes keypresses in accordance with the teachings of the present invention.

DETAILED DESCRIPTION OF THE PREFERRED EMBODIMENTS

In general, the teachings of the present invention pertain to the integration of an AM/FM receiver into a personal communication device. The result of this integration is referred to as a dual purpose, hand-held communication device (hereinafter "dual purpose communication device").

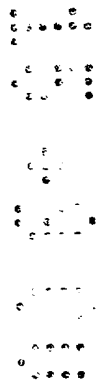

The dual purpose communication device enables a user to listen to audio from broadcast AM or FM signals and to receive and/or transmit personal communication information via a single device. As will be appreciated by those skilled in the art, and as disclosed herein, personal communication devices could include, but are not limited to, mobile telephones (e.g., analog or digital cellular telephones, PCS telephones and the like) and pagers (e.g., one-way and two-way pagers). As disclosed herein, the pertinent aspects of integrating an AM/FM receiver and a personal communication device include, but are not limited to, AM antenna design, matching an existing mobile telephone antenna to an FM receiver, integration of an AM/FM receiver with personal communication device hardware, and the reuse of existing personal communication device hardware.

Referring now to FIG. 1, a dual purpose communication device 10 generally includes a personal communication portion 12 and an AM/FM receiver portion 14. The personal communication portion 12, which could be embodied in a mobile telephone or a pager, includes a display 16 such as a light emitting diode (LED) display or a liquid crystal display (LCD) and a processor 18. The processor 18 interfaces with, and controls, the display 16 in a manner that is known to those skilled in the art. Additionally, the processor 18 interfaces with, and controls, the AM/FM receiver portion 14.

Generally, the AM/FM receiver portion 14 includes a radio integrated circuit (radio IC) 20 that is communicatively coupled to a synthesizer 22. The radio IC 20 and the synthesizer 22 are controlled by the processor 18 and cooperate to receive AM or FM radio signals and to deliver the received signals to a consumer via a sound generating device such as a speaker or an earpiece (not shown). In some embodiments of the AM/FM receiver portion 14, the radio IC 20 and the synthesizer 22 are integrated into a single hardware component. Alternatively, the radio IC 20 and the synthesizer 22 are separate components. Embodiments in which the radio IC 22 and the synthesizer 22 are integrated into a single hardware component are described in conjunction with FIGS. 2 and 4 hereinafter, while embodiments

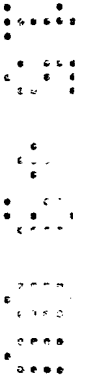

in which these components are separate are described in conjunction with FIGS. 3 and 5 hereinafter.

As shown in FIG. 2, a dual purpose communication device 40 includes an antenna 42 that is operatively coupled to both a mobile telephone receiver 44 and an AM/FM receiver 46. The AM/FM receiver 46 is adapted to receive AM signals between 535 kilohertz and 1705 kilohertz and FM signals between 88 megahertz and 108 megahertz and includes an AM/FM receiver IC 48 and external tuning elements 50 that are operatively coupled to the AM/FM receiver IC 48. A processor 54 controls the functionality of the dual purpose communication device 40 and receives input from a keypad (not shown). In particular, the processor 54 controls the functionality of both the AM/FM receiver IC 48 and a display driver 56, which, in turn, controls the functionality of a display (not shown), such as an LCD or an LED display.

Both the mobile telephone receiver 44 and the AM/FM receiver IC 48 are operatively coupled to an audio processing block 60 that includes first, second and third analog switches 62, 64 and 66, respectively. Audio that is output from the mobile telephone receiver 44 is monoaural and therefore has a single audio channel that is coupled to the first analog switch 62. The audio that is produced by the AM/FM receiver IC 48, which may be a Philips TEA5757 component having an integrated synthesizer, is stereo and therefore has left and right channels that are coupled to the second and third switches 64, 66, respectively. The audio processing block 60 is used to control the audio signals that are communicated to the user.

A dedicated button 68 on the outside of the dual purpose communication device 40 operates in conjunction with an inverter logic gate 70, such as a 74HC04, to control the first, second and third switches 62, 64, 66 of the audio processing block 60. Additionally, the button 68 is interfaced to the processor 54 and acts as a hookswitch for the mobile telephone, thereby activating and deactivating the mobile telephone as the state of the button 68 changes. Preferably, the audio processing block 60 is embodied in a 74HC4066. When the button 68 is in a first position, the first switch 62

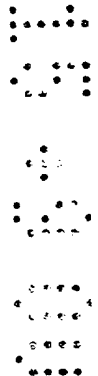

couples the output from the mobile telephone receiver 44 to an audio output device 74 such as a volume control block and the second and third switches 64, 66 prevent the output of the AM/FM radio IC 48 from reaching the audio output device 74. Conversely, when the button 68 is in a second position, the second and third switches 64, 66 couple the output from the AM/FM receiver IC 48 to the audio output device 74 and the first switch 62 prevents the output from the mobile telephone receiver 44 from reaching the audio output device block 74.

The audio output device 74 is controlled by an up volume button 76 and a down volume button 78, each of which is disposed on the outside of the dual purpose communication device 40. When the dual purpose communication device 40 is used to receive personal communication information, the up and down volume buttons 76, 78 control the volume of the audio that emanates from a speaker 80. Alternatively, when the dual purpose communication device 40 is used to receive AM or FM radio signals, the up and down volume buttons 76, 78 control the amplitude of an audio signal that is coupled to a headphone jack 84, which accommodates stereo headphones (not shown). Accordingly, depending on the mode in which the dual purpose communication device 40 is operating (which is controlled by the button 68 that is interfaced to the processor 54), the audio output device 74 interacts with the up and down volume buttons 76, 78 to control the volume of the audio that is delivered to the user's ear.

The dual purpose communication device 40 includes a phone audio summing point 86 that allows whichever signal is present at the headphone jack 84 to pass to the speaker 80. Additionally, alert audio summing points 88 are provided to combine an alert signal with AM/FM audio from the AM/FM receiver IC 48 so that when a user is listening to an AM or FM radio station, an audible alert signal similar to a call waiting audio signal can be presented to the user to alert the user to the fact that a call is incoming.

Also included in the dual purpose communication device is a mobile telephone transmitter 90 that is communicatively coupled to the antenna 42

and an input device 91 such as a microphone. As will be appreciated by those skilled in the art, the transmitter may be any known or desired transmitter that is used to convert voice signals into electrical signals that are transmitted by the antenna 42.

5 While a user is listening to an AM or FM radio station that is received by the AM/FM receiver 46 and communicated to the user via headphones that are connected to the headphone jack 84, a personal communication such as a telephone call can be received by the mobile telephone receiver 44. The dual purpose communication device 40 produces an alert signal that is
10 coupled to the alert audio summing points 88 to inform the user of the incoming communication. In response to the alert signal, the user changes the state of the button 68, thereby disconnecting the AM/FM audio from the headphones and connecting the received audio from the mobile telephone receiver 44 to the speaker 80 and entering the user into a mobile telephone
15 call. Throughout the telephone call, the mobile telephone receiver 44 and the mobile telephone transmitter 90 receive and send information pertinent to a telephone conversation via the antenna 42.

In some instances, the user could desire to put the caller on hold. During a period of time that the caller is on hold, AM/FM audio from the
20 AM/FM receiver 46 could be coupled to the transmitter so that the caller hears the AM/FM audio as hold music. When the user has completed his or her telephone call, he or she changes the state of the button 68, which terminates the telephone call and routes AM/FM audio to the headphones via the headphone jack 84.

25 An alternative embodiment of the dual purpose communication device 40 shown in FIG. 2, is shown in FIG. 3 and is designated by reference numeral 100. Like reference numerals are used to signify like elements between the dual purpose communication device 40 and the dual purpose communication device 100. From the user's perspective, the functionality of
30 the dual purpose communication device 100 is identical to that described in conjunction with FIG. 2. Differences between the embodiments shown in

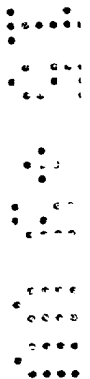

FIGS. 2 and 3 are the hardware used to implement the AM/FM receiver and the processor. The following description, given with respect to FIG. 3, will focus on these differences.

As shown in FIG. 3, an AM/FM receiver 104 generally includes an AM/FM receiver IC 106, which may be embodied in a Sony CXA1538N component, and an external synthesizer or phase locked loop (PLL) 108, which may be embodied in a Rohm BU2616 component. Also included are a number of tuning coils and filters 110, buffers 112 and a low pass filter 114, all of which are operatively coupled to the AM/FM receiver IC 106 and the synthesizer 108. Additionally, a processor 116 is provided and is operatively coupled to the AM/FM receiver IC 106, the synthesizer 108, and the mobile telephone keypad (not shown). Generally, the AM/FM receiver IC 106, which is coupled to the antenna 42, the synthesizer 108, the tuning coils and filters 110, the buffers 112 and the low pass filter 114, receives and demodulates AM or FM signals to obtain audio signals that are then coupled to the audio processing block 60. In particular, the AM/FM receiver IC 106 receives AM/FM signals from the antenna 42 and downconverts them using intermediate frequencies that are generated by the tuning coils and filters 110, the oscillation frequencies of which are controlled by signals from the synthesizer 108. The synthesizer 108 controls the oscillation frequencies of both an AM tuning coil and an FM tuning coil based on a tuning frequency that the consumer selects (e.g., the frequency of the station to which the consumer wants to listen).

A dual purpose communication device 120 that integrates the functionality of a pager and an AM/FM receiver is shown in FIG. 4. Like elements are found in the dual purpose communication device 40 are identified by like reference numerals. In addition to performing the conventional functions or receiving and displaying paging information such as text and numbers, the dual purpose communication device 120 allows a user to listen to AM or FM radio stations. The dual purpose communication device 120 includes a pager receiver 122, an antenna 124, an alert/speaker 126, a

processor 128 and a display 130. Additionally, the dual purpose communication device 120 includes the AM/FM receiver 46, which includes the AM/FM receiver IC 48, tuning coils and filters 50, the display driver 56, the headphone jack 84 and the alert audio summing nodes 88.

5 In conventional operation, the pager receiver 122 is coupled to the antenna 124, which receives signals from a paging system. Conventionally, and as with the present embodiment, when paging information is received by the antenna 124, the pager receiver 122 generates an alert signal. The alert signal is coupled to an alert/speaker 126 that informs the user that a page
10 has been received. Almost simultaneously with the generation of the alert signal, the pager receiver 122 operatively couples the received paging information to the processor 128. The processor 128 interfaces with the display driver 56 and together these components operate the display 130 to display information to the user. Alternatively, a voice synthesizer could be
15 used to synthesize a voice signal representative of the page information and could couple the voice signal directly to the headphone jack 84. Such an arrangement alleviates the need for a user to look at the display when paging information is received.

In accordance with the present invention, the AM/FM receiver IC 48,
20 which may be a Philips TEA5757 component having an integral synthesizer, receives AM/FM signals from the antenna 124 and produces left and right audio channels that represent audio information from the AM and FM signals. The left and right audio channels are coupled to the audio output device 74 and further to the headphone jack 84, which is adapted to receive
25 conventional headphones that are commonly used with many personal AM/FM radios. If a user is listening to AM or FM audio generated by the AM/FM receiver 46 when he or she receives a page from a paging system, the pager receiver 122 generates the alert signal that is coupled to the headphone jack 84 via the alert audio summing points 88. Accordingly, a
30 user that is listening to the radio will be alerted via an audio alert that he or she has received a page.

An alternate embodiment of a dual purpose communication device 140 that integrates the functionality of a pager and an AM/FM receiver is shown in FIG. 5. The embodiment shown in FIG. 5 differs from the embodiment shown in FIG. 4 in that the AM/FM receiver 46 has been replaced by the AM/FM receiver 104 that includes the AM/FM receiver IC 106, the synthesizer 108, the tuning coils and filters 110, the buffers 112 and the low pass filter 114. Additionally, the processor 128 from FIG. 4 has been replaced by a processor 142 in FIG. 5. The AM/FM receiver 104 functions as described in conjunction with the AM/FM receiver shown in FIG. 3. To the user, the embodiments shown in FIGS. 4 and 5 function identically or nearly identically.

The foregoing embodiments shown in FIGS. 2-5 all employ a stand-alone architecture because the AM/FM receivers 46, 104 function independently of the mobile telephone receivers 44 or the pager receivers 122. Such an architecture permits the AM/FM receiver to be utilized at the same time the mobile telephone receiver 44 or the pager receiver 122 is used. While this architecture is advantageous, it would be additionally advantageous to provide the additional functionality of an AM/FM receiver in a mobile telephone or a pager using existing hardware within the mobile telephone or pager, thereby minimizing cost, weight size and current drain.

As shown in the integrated approach of FIG. 6, a radio frequency (RF) and audio section 150 designed in accordance with the teachings of the present invention provides AM/FM receiver functionality in a mobile telephone and uses existing hardware from the mobile telephone. The RF and audio section 150 includes a mobile telephone antenna 152, mobile telephone front end circuitry 154, an AM antenna 158, AM preselect circuitry 160, AM front end circuitry 162, an FM antenna 166, FM preselect circuitry 168 and FM front end circuitry 170. Each of the mobile telephone front end circuitry 154, the AM front end circuitry 162 and the FM front end circuitry 170 receive input signals from a synthesizer 174 and have their outputs coupled to a selector 178. The selector 178, in turn, is coupled to a zero intermediate frequency integrated circuit (ZIF IC) 180, the output of which is coupled to an AM

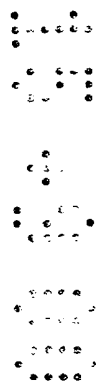

detector 182 and to an FM detector 184. In some embodiments, the AM detector 182 and/or the FM detector 184 may be integrated into the ZIF IC 180. The outputs of each of the AM detector 182 and the FM detector 184 are coupled to a decoder 186. Of the components shown in FIG. 6, the mobile telephone front end circuitry 154, and the ZIF IC 180 are components already used within a mobile telephone.

In operation, the mobile telephone antenna 152 passes signals to the mobile telephone front end 154, which processes the signals to generate a first intermediate frequency (IF) mobile telephone signal. Similarly, the AM antenna 158, the AM preselect circuitry 160 and the AM front end circuitry 162 generate an IF AM signal and the FM antenna 166, the FM preselect circuitry 168 and the FM front end circuitry 170 generate an IF FM signal. Each of the IF mobile telephone signal, the IF AM signal and the IF FM signal are provided to the selector 178.

The selector 178, which may be embodied in a transistor switch or a pin switch, is controlled by a processor (not shown) and is used to select one of the IF mobile telephone signal, the IF AM signal and the IF FM signal for coupling to the ZIF IC 180. The ZIF IC 180 downconverts the selected signal from a radio frequency signal to a baseband signal that is either AM or FM modulated. If the baseband signal is AM modulated, it is coupled from the ZIF IC 180 to the AM detector 182, which demodulates the AM modulated signal. If the baseband signal is FM modulated, it is coupled from the ZIF IC 180 to the FM detector 184, which demodulates the FM modulated signal. The output signals from the AM detector 182 and the FM detector 184 are coupled to the decoder 186, which processes these signals into left and right audio channels. In addition to audio information, the IF mobile telephone signal may include barker information that alerts the mobile telephone of an incoming communication. Such signals are recognized by the decoder 186 and are used in a manner known to those skilled in the art to alert the user of incoming communication.



While a user is listening to, for example, an FM radio station, the selector 178 selects the output of the FM front end circuitry 170 to be coupled to the ZIF IC 180. The ZIF IC 180 in conjunction with the FM detector 184 and the decoder 186 generates left and right channel audio representative of the information in the FM signal. Similarly, signals from the mobile telephone front end circuitry 154 or the AM front end circuitry 162 may be coupled to the ZIF IC 180 by the selector 178 to eventually produce audio based on those signals.

The use of the ZIF IC 180 enables the RF and audio section 150 to receive and process only one RF signal at a time. However, a user that is listening to AM or FM audio likely desires to receive incoming calls to the mobile telephone should they occur. In accordance with the teachings of the present invention, while the user is listening to the AM or FM radio, the RF and audio section 150 tunes the synthesizer 174 away from the AM or FM first IF signal and to the mobile telephone first IF signal, while the selector 178 couples the output from the mobile telephone front end circuitry 154 to the ZIF IC 180. Tuning away from the AM or FM signal is necessary to allow the RF and audio section 150 to check for barkers that are indicative of incoming mobile telephone communication. Tuning away from an audio source, such as an AM or FM signal, to look for a barker may be imperceptible to the user that is listening to the audio source if appropriate audio filtering and processing are used.

In accordance with the present invention, audio filtering and processing are used to make tuning away from an audio source to look for a barker imperceptible to the user that is listening to the audio source. Tuning away is done periodically (e.g., every 0.5, 1.0 or 2.1 seconds) and lasts for approximately 20 milliseconds (ms), which means that FM or AM audio to which the user is listening will be interrupted for 20ms every 0.5 to 2.1 seconds. An abrupt interruption of AM or FM audio is perceptible to the user. In accordance with the present invention, gradual smoothing of the audio interruption is used to make the audio interruption less perceptible.

Preferably, audio is gradually attenuated from the level to which the user is listening, to a level that is approximately zero over 1.25ms preceding the 20ms audio interruption. This scheme is such that 1.25ms after the gradual attenuation begins, audio is completely interrupted. By using gradual
5 attenuation, the interruption is smooth and less audibly perceptible. After the 1.25ms gradual attenuation and the 20ms audio interruption, audio is gradually increased from zero to its preattenuated level over the next 1.25ms.

In addition to gradual attenuation before the 20ms interruption and gradual increase after the 20ms interruption, audio filling is used during the
10 20ms interruption. Audio filling consists of storing in memory a 20ms segment of audio that immediately precedes the 20ms interruption and then delaying that 20ms segment and inserting it into the audio path during the 20ms interruption. After the audio filling is complete, the audio signal is filtered using a 3-pole, 15 kilohertz (KHz) Bessel filter within the decoder 186 to
15 smooth any sudden phase changes at the edges of the 20ms interruption. Gradually attenuating the audio level, using audio filling and gradually increasing audio level, when used in combination with the 15KHz filtering, yields a system wherein an audio interruption associated with tuning away from the AM or FM audio source is extremely difficult to audibly perceive.

Alternatively, other or additional schemes may be used to minimize the
20 perception of audio interruptions. One such scheme includes filling the 20ms interruption with a segment of speech made before the interruption and a segment of speech following the interruption, in addition to gradually attenuating the audio before the interruption and gradually increasing the
25 audio after the interruption. The use of the following audio segment to fill the audio interruption introduces time delay into the audio system. However, because the reception of AM or FM audio is simplex, this time delay does not create any problems within the system and is audibly imperceptible. Another way to assure continuity at the start and end of the 20ms interruption is to flip
30 the prior and following audio segments rather than shifting them. Other schemes that can be used to decrease the perceptibility of the interruption

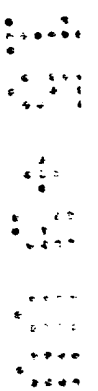

can be found in "Waveform Substitution Techniques for Recovering Missing Speech Segments in Packet Voice Communications", December 1986, IEEE Transactions on Acoustics, Speech and Signal Processing; "The Effect of Waveform Substitution on the Quality of PCM Packet Communication", March 1988, IEEE Transactions on Acoustics, Speech and Signal Processing; and "A Class Oriented Replacement Technique for Lost Speech Packets", October 1989, IEEE Transactions on Acoustics, Speech and Signal Processing.

Whether an AM/FM receiver is a separate component as shown in FIGS. 2-5 or integrated with, and uses, the mobile telephone hardware as shown in FIG. 6, a dual purpose communication device requires an AM antenna to receive AM signals. As described below in conjunction with FIGS. 7 and 8, an AM antenna may take various forms.

Referring to FIG. 7, a set of headphones 200 includes a first embodiment of an AM antenna 202, which may be in the form of a loopstick antenna, and headphone speakers 204. The headphones 200 are interfaced to a dual purpose communication device circuit board 206 via a set of wires 208. The wires 208, in addition to carrying audio to the headphone speakers 204, differentially feed the rod AM antenna 202, which may be a ferrite rod AM antenna. The circuit board 206 includes an audio source 210, which represents audio output from an AM or FM receiver, that is coupled to the wires 208 via coils 212, which block AM and FM RF signals and pass audio frequency signals to the headphone speakers 204. The AM antenna 202 is capacitor coupled via the wires 208 to AM antenna terminals 214 to provide received AM signals to an AM receiver (not shown in FIG. 7).

In a second embodiment, an AM antenna is embodied in an air-wound planar coil that is printed on a layer of a printed circuit board. Such an AM antenna is constructed to have approximately 50 turns and to have a cross-section of 2500 square millimeters (mm). In some embodiments, this type of antenna is implemented as printed loops on the perimeter of a multilayer printed circuitboard having 5-10 loops connected in series using plated

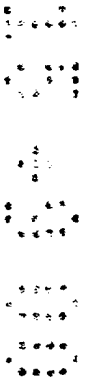

through holes or vias (not depicted). Such an antenna is very low cost and lightweight.

A third AM antenna configuration is a AM loop antenna that is embedded in the housing of a dual purpose communication device. Similar to the printed circuit board AM antenna described above, this AM antenna uses approximately 50 turns of wire and has approximately a 2500 square millimeter cross section. However, this AM antenna is embedded in the housing of the dual purpose communication device. As shown in FIGS. 8a-8f, an AM antenna 216 may be embedded in various locations within a housing 218 of a dual purpose communication device. For example, the AM antenna 216 may be embedded in the upper front of the housing 218 (FIG. 8a), the upper front and lower front of the housing 218 (FIG. 8b), around the periphery of the front of the housing 218 (FIG. 8c), along the side of the housing 218 (FIG. 8d), around the periphery of the rear of the housing 218 (FIG. 8e) or around the bottom of the housing 218 (FIG. 8f). The main consideration that governs the placement of the antenna 216 within the housing 218 is interference to and from the circuitry of the dual purpose communication device. Generally, an antenna 216 is placed in the housing away from any processor or microcontroller clock signals and away from the areas where a user will place his or her hand to hold the dual purpose communication device.

Referring to FIG. 9, a headset 219 having an antenna adapted for FM frequency band signal reception generally includes two headphone speakers 220a, 220b having common DC ground wires 221 and each having an audio signal wire 222a, 222b. The audio delivered to the headphone speakers 220a, 220b, depends on the mode of operation in which a dual purpose communication device is placed. For example, if the dual purpose communication device is in mobile telephone mode, mobile telephone audio is delivered to the headset speakers 220a, 220b. Conversely, if the dual purpose communication device is in a mode to receive FM radio signals, FM radio audio is coupled to the headset speakers 220a, 220b.

A microphone 223 is provided and connected to the DC ground wire 221 to convey a user's voice to the mobile telephone during operation of the mobile telephone. The DC ground wire 221 is shielded by a ground mesh 233 and is connected to ground through an inductor 224. The inductor 224 prevents any FM or audio signals from being shorted to ground, while providing DC ground for the speakers 220a, 220b. The DC ground wire 221, which carries audio generated by the microphone 223 is coupled to a mobile telephone transmitter for broadcast to a mobile telephone system.

Capacitors 225a and 225b are used to connect audio signal wires 222a and 222b together to form an FM antenna that receives FM frequency band radio signals. The FM frequency band radio signals received by the FM antenna are coupled to a capacitor 226, which is sized to pass the FM frequency band signals and to block audio signals. A series inductor 227, which is connected to the capacitor 226, is sized to pass the FM frequency band signals and to block mobile telephone frequency signals (e.g., GSM and DCS band signals).

An FM match consisting of an inductor 228a and a capacitor 228b, having values of 290 nanohenrys(nH) and 6.8 picofarads(pF), respectively, couples the FM frequency band signal to an FM receiver. The FM receiver, which may be represented by a signal source 229, generates audio based on the FM frequency band signals and couples the audio signals through inductors 230a and 230b to the headphone speakers 220a, 220b. When the mobile telephone is in operation, audio generated by a mobile telephone receiver is represented by the signal source 229 and is coupled to the headphone speakers 220a, 220b.

Whether an AM/FM receiver is a stand-alone component as shown in FIGS. 2-5 or integrated into the mobile telephone hardware as shown in FIG. 6, a dual purpose communication device requires an FM antenna to receive FM signals. In stand-alone or integrated applications, one particularly advantageous approach includes the use of a conventional or existing mobile telephone antenna that is already used by the dual purpose communication



device to receive personal communication information. The use of the conventional or existing mobile telephone antenna for the reception of personal communication signals and FM radio signals requires that the conventional or existing mobile telephone antenna be impedance matched to both a mobile telephone receiver and an FM receiver.

A first embodiment of an impedance matching circuit 231, as shown in FIG. 10, generally includes a transmission line 232 that connects a mobile telephone antenna 234 to a mobile telephone transceiver impedance match 236, an FM receiver impedance match 238 and a pair of tuning varactors 240. The FM receiver impedance match 238 couples the mobile telephone antenna 234 to an AM/FM receiver 242 and the mobile telephone receiver impedance match 236 couples the mobile telephone antenna 234 to a mobile telephone transceiver 244.

The mobile telephone transceiver impedance match 236 includes capacitors 246, 248 and inductors 250, 252, 254, 256, which are connected as shown in FIG. 10. Inductors 254 and 256 may be commercially available components from Toko America (Toko) under model numbers LL1608-FS10N and LL1608-FS12N, respectively, which have inductance of 10nH and 12nH, respectively. During operation, inductors 250 and 252 are resonated with the capacitor 246, which has a value of 3.3pF, at the FM band to prevent any FM signals received by the antenna 234 from being shunted to ground. Capacitor 248 couples inductor 254 to inductor 256.

The FM receiver impedance match 238 includes inductors 258, 260 that provide an electrostatic discharge (ESD) path to ground from the mobile telephone antenna 234. The inductors 258, 260 may be commercially available components from Murata under model numbers LQN1HR50J04 and LQN1H54NK04, respectively, and have values of 500nH and 54nH, respectively. The mobile telephone receiver impedance match 236 is buffered from the capacitance of the tuning varactors 240 by inductors 250, 252.



The tuning varactors 240 are commercially available from Toko under model number KV1471 and are controlled by a tuning voltage to allow the FM receiver impedance match 236 to operate over the entire FM frequency band when the tuning voltage is between 0.8V to 1.9V. Alternatively, the tuning varactors 240 may be driven by a voltage range extender circuit shown in FIG. 12, which provides a tuning voltage range of 0.8V to 4.75V.

A second embodiment of an impedance matching circuit 270, as shown in FIG. 11, generally includes a transmission line 272 that connects a mobile telephone antenna 274 to a mobile telephone transceiver impedance match 276 and an inductor 278, which may be a 750nH inductor sold by Murata under model number LQN1HR75J04, that serves as an FM receiver impedance match. The mobile telephone transceiver impedance match 276 connects the transmission line 272 to a mobile telephone transceiver 280 and the inductor 278 connects the transmission line 272 to an AM/FM receiver 282. The impedance matching circuit 270 also includes tuning varactors 284 that are used for tuning within in the FM band. An inductor 286, which is a 390nH inductor sold by Murata under model number LQN1HR39J04, is connected in parallel with two inductor-capacitor networks 288, 290, and causes the inductor-capacitor networks 288, 290 to resonate at FM frequencies to prevent FM signals from shunting to ground through other matching circuitry. Inductor-capacitor network 288 includes an inductor 292, which may be a 3.3nH inductor sold by Toko under model number LL1608-FS3N3, and a capacitor 294, which is 2.2pF. Inductor-capacitor network 290 includes an inductor 296, which is a 4.7nH inductor sold by Toko under model number LL1608-FS4N7, and a capacitors 298, which is 6.8pF. Inductor-capacitor networks 288 and 290 are tuned to be short circuits at GSM frequencies (800MHz) and at DCS frequencies (1800MHz), respectively, to isolate the mobile telephone receiver impedance match 276 from the capacitance of the tuning varactors 284.

The mobile telephone receiver impedance matching circuit 276 includes a capacitor 300 that has a value of 3.6pF and an inductor 302, which

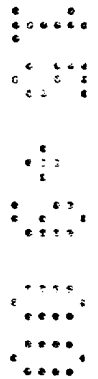

may be a 5.6nH inductor sold by Toko under model number LL1608-FS5N6. An inductor 304 having a value of 215nH is connected in parallel with the capacitor 300 and together these components resonate at the FM band.

A voltage range extender circuit 310, as shown in FIG. 12, includes an input port 312, an operational amplifier (op-amp) 314, resistors 315, 316 and 317, an op-amp 318, a feedback resistor 320, and output port 322 and a phasing arrangement 324. The voltage range extender circuit 310 extends the voltage range at the input port 312 to a wider voltage range at the output port 322. This function is desirable because it allows tuning varactors (shown in FIGS. 9 and 10) to be driven over a wider capacitance range using a limited voltage supply range. For example, the voltage range extender circuit 310 allows an input voltage range from 0.8V to 1.9V to be extended to 0.8V to 4.75V.

The phasing arrangement 324 includes a ground resistor 330, a supply resistor 332, three phasing resistors 334, 336 and 338, three phasing transistors 340, 342 and 344, three phasing input connections 350, 352 and 354 and a phasing supply connection 356, which is connected to a supply voltage of 4.75V or 5V. Generally, the various components of the phasing arrangement 324 cooperate to generate a threshold voltage referred to as V_{th} . Specifically, when all of the phasing input connections 350-354 are at a voltage potential equal to the voltage potential at the phasing supply connection 356, the phasing transistors 340-344 are in cutoff mode of operation and, therefore, no current flows through the phasing resistors 334-338. Under such circumstances, the threshold voltage (V_{th}) is set by a voltage divider created between resistors 330 and 332. Preferably, the threshold voltage (V_{th}) is set at 0.58V by the resistors 330 and 332. However, because of the tolerances involved in the resistors 330 and 332, the phasing input connections 350-354 and their associated phasing transistors 340-344 and phasing resistors 334-338 are used to tune the threshold voltage to 0.58V. For example, if V_{th} is too low, the phasing input connection 350 may be held to a low logic level. Under such circumstances,

the phasing transistor 340 saturates, thereby effectively placing resistor 334 in parallel with resistor 332 and increasing the voltage across the resistor 330. Preferably, resistor values are chosen such that V_{th} is 0.58V with the phasing arrangement 324 set to the middle of its range, thereby allowing the phasing arrangement 324 to compensate for tolerances in resistor 330 and 332 that make V_{th} too high or too low.

During operation of the voltage range extending circuit 310, a tuning voltage is coupled to the input port 312 and is buffered by the op-amp 314, which is configured as a unity gain buffer. The op-amp 318 along with resistors 315, 316 and 317, the threshold voltage (V_{th}) and the feedback resistor 320, generates an output voltage at the output port 322. The output voltage at the output port 322 is represented by equation 1.

Equation 1 $V_{322} = (3.6) * (V_{312} - V_{th})$ Wherein, V_{322} is the voltage at the output port 322, V_{312} is the voltage at the input port and V_{th} is the threshold voltage. The constant 3.6 is set by the resistance ratios of resistors in the circuit. Specifically, the ratio of resistor 320 to resistor 317 and the ratio of resistor 315 to resistor 316 are set to be equal to 3.6 and resistors 330 and 332 are selected to be much less than the values of resistors 315 and 320.

As seen by equation 1, when V_{th} is set at 0.58V, an input voltage of 0.8V yields an output voltage of 0.8V and when the input voltage is 1.9V the output voltage is 4.75V, thereby extending the voltage range across which the tuning varactors in FIGS. 11 and 12 may be tuned.

As shown in FIG. 13 a user interface of a dual purpose communication device 370, which is embodied in a mobile telephone having an AM/FM receiver, includes a display 372, a keypad 374, an earpiece 376, a headphone jack 378, an antenna 380 and a dedicated button 382. As indicated previously, the dedicated button 382 controls whether the dual purpose communication device 370 is in a mode for receiving AM/FM radio signals or in a mode for receiving mobile telephone communications. When the dual purpose communication device 370 is in the mode for receiving

mobile telephone communications, it behaves like a conventional mobile telephone. For example, the keypad 374 allows the user to dial and the dialed numbers appear on the display 372.

5 However, when the dual purpose communication device 370 is in the mode to receive AM/FM radio signals, the keypad 374 is used as a user interface for controlling the reception of the AM/FM radio signals and the display 372 is used to display information relevant to AM/FM radio reception. Keypad 374 controls for AM/FM radio reception may include conventional AM/FM receiver controls such as mute, incremental increasing and decreasing tuning, channel seek tuning and channel scan tuning, and
10 programmable tuning presets. Preferably, the programmable tuning presets will be accessed using keys 1-8 of the keypad 374. Keys 1-9 of the keypad 374 are used to directly enter a frequency of a radio station to which the user wishes to listen. For example, if a user wishes to listen to 93.1 MHz FM, he or she will press the "9" key, the "3" key and the "1" key. The key reading mechanism of the dual purpose communication device 370 is programmed to recognize that a decimal point should be placed between the entered "3" and the entered "1" because the first digit entered was not a "1". If, however, the
15 "1" key was pressed first, the dual purpose communication device would wait for the user to enter three more digits before programming a station into the AM/FM receiver. A more thorough description of the key reading mechanism or process is given with respect to FIG. 14 below.

20 Preferably, the display 372 includes a stereo or mono indicator 386, a preset channel indicator 388, a tuning indicator 390, an AM/FM indicator 392, a signal strength indicator 394, and a battery level indicator 396. The display 372 is such that when the user changes the setting of the AM/FM receiver via the keypad 374, the display 372 is automatically, and seemingly instantaneously, updated. As will be appreciated by those of ordinary skill in the art, the display 372 may contain more or fewer indicators.

30 Referring now to FIG. 14, a flow diagram of how the dual purpose communication device 370 processes keypresses is shown. Such a process

may be implemented using software executed by a processor or by any other means. A block 404 waits for any key on the keypad 374 to be pressed. When a keypress is detected, control is passed to a block 406 that determines if the AM/FM receiver is in AM mode. If the receiver is in AM mode, control is passed to a block 408 that decodes the key that was pressed to determine which function is to be performed. After the keypress is decoded, control is passed to a block 410, which writes relevant information to the display 372 based on the key that was pressed. After the display 372 is updated, control passes to a block 412, which determines if the keypress that was just made is a final keypress in a sequence or if more key presses are expected. If no more keypresses are expected, control is passed to a block 414 that performs the function of programming an AM/FM receiver to a desired frequency based on the previously-decoded keypresses.

If the block 412 determines that the most recently decoded keypress is not the final keypress, control is passed to a block 416, which in turn is coupled to a block 418. Together the blocks 416 and 418, await a keypress and, if a keypress is received, pass control back to the block 408 for decoding. If a keypress is not received, control passes from the block 416 to the block 418 that determines if a time out has occurred. A time out allows a user a specific period of time between keypresses. If a keypress that is not a final keypress occurs and no subsequent keypress is received before the time out occurs, control is passed from the block 418 to a block 420, which reverts to the station that was previously displayed before the initial keypress was detected by the block 404. If the time out has not occurred, control is passed from the block 418 back to the block 416. Together blocks 416 and 418 wait for keypresses until a time out occurs.

In operation, the blocks 404 to 420 operate as follows. When a keypress is detected by the block 404 and the AM/FM receiver is in AM mode, the block 408 detects the keypress, which for the sake of example will be assumed to be "1". The block 410 writes a "1" into the tuning indicator on the display 372. The block 412 determines that the "1" keypress must be

followed by additional keypresses and the block 416 checks to see if a subsequent keypress has occurred as long as a time out has not occurred. When a subsequent keypress is detected, the block 408 detects the keypress and the block 410 writes the new keypress to the display 372. This iterative operation occurs until there is a time out occurs between keypresses or a final keypress is entered.

The determination of a final keypress is dependent on the keypresses already made. For example, if the AM/FM receiver is in AM mode and "6" and "7" and "0" have been keyed in, the block 412 knows that the "0" is the final keypress. This assumption can be made because there are no four digit AM stations that begin with a "6". Similarly, if "1", "2" and "0" are entered, the block 412 knows that the "0" is not the final digit because there are no three digit AM stations that begin with a "1" and, therefore, the block 416 waits for a fourth keypress.

If the block 406 determines that the dual purpose communication device 370 is not in AM mode, control is passed to block 430, which determines if the dual purpose communication device is in FM mode. If the dual purpose communication device is in FM mode, key decoding is carried out in a substantially identical manner as disclosed in conjunction with the foregoing description with respect to blocks 408-420. A block 432 decodes keypresses and, after the keypresses are decoded, passes control to a block 434, which updates the display to reflect the keypress. A block 436 determines if a final keypress has been made and if it has, control passes to a block 438, which tunes the AM/FM receiver to the frequency that is designated by the keypresses. If the final keypress has not been received, control passes to a block 440 and a block 442, which detect subsequent keypresses that occur before a time out occurs. If a time out occurs, the display 372 is returned to the state that it was before the block 404 detected a keypress. If, however, a keypress is detected by the block 440 before a time out, control is passed to the block 432 for decoding of the keypress.

Blocks 432, 434, 436 and 440 iteratively detect and decode keypresses until a final keypress is received or a time out occurs.

5 If, after a keypress detected by the block 404, the dual purpose communication device is not in AM or in FM mode, it must be in a mobile communicator mode, in which case control passes from the block 430 to a block 450. The block 450 represents all of the traditional key decoding operations that take place in a mobile telephone. The block 450 operates in any desired manner that a mobile telephone would operate because the operation of the mobile telephone is independent of the presence of an
10 AM/FM receiver such that a user would notice no substantial difference between the operation of a mobile telephone with or without the AM/FM receiver.

The foregoing description has been presented for the purposes of illustration and description. It is not intended to be exhaustive or to limit the
15 invention to the precise form disclosed. Many modifications and variations are possible in light of the above teachings. It is intended that the scope of the invention be limited not by this detailed description, but rather by the claims appended hereto.

What is claimed is:

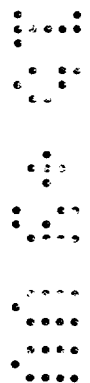

CLAIMS

1. A dual purpose, hand-held wireless communication device comprising:

5 an audio output device;

a first receiver adapted to receive radio broadcast transmissions and to produce a first audio signal associated with the radio broadcast transmissions;

10 a second receiver adapted to receive communication information and to produce a second audio signal associated with the communication information; and

15 an audio processing block communicatively coupled to the first receiver and the second receiver, wherein the audio processing block is adapted to selectively couple one of the first audio signal and the second audio signal to the audio output device.

2. The dual purpose, hand-held wireless communication device of claim 1, further comprising:

20 an input device adapted to receive a third audio signal and to produce a signal for transmission associated with the third audio signal; and

a transmitter communicatively coupled to the input device and adapted to transmit the signal for transmission.

3. The dual purpose, hand-held wireless communication device of claim 2, wherein the second receiver and the transmitter comprise cellular mobile telephone components adapted to communicate with a mobile telephone network.

4. The dual purpose, hand-held wireless communication device of claim 1, further comprising an antenna operatively coupled to the first receiver and operatively coupled to the second receiver.

5. The dual purpose, hand-held wireless communication device of claim 4, further comprising:

- a first antenna operatively coupled to the first receiver; and
- a second antenna operatively coupled to the second receiver.

5

6. The dual purpose, hand-held wireless communication device of claim 4, further comprising a display adapted to display a frequency to which the first receiver is tuned.

7. The dual purpose, hand-held wireless communication device of claim 6, wherein the display is further adapted to display a preset channel indicator.

10

8. A dual purpose, hand-held wireless communication device comprising:

an audio output device;

a first receiver adapted to receive radio broadcast transmissions and to produce a first audio signal associated with the radio broadcast transmissions;

15

a second receiver, adapted to receive communication information associated with a telephone conversation and to produce a second audio signal associated with the communication information associated with a telephone conversation; and

20

an audio processing block communicatively coupled to the first receiver and the second receiver, wherein the audio processing block is adapted to selectively couple one of the first audio signal and the second audio signal to the audio output device.

25

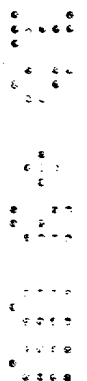

9. The dual purpose, hand-held wireless communication device of claim 8, wherein the radio broadcast transmissions comprise amplitude modulated signals.

5 10. The dual purpose, hand-held wireless communication device of claim 8, wherein the radio broadcast transmissions comprise frequency modulated signals.

11. The dual purpose, hand-held wireless communication device of claim 8, further comprising:

10 an input device adapted to receive a third audio signal and to produce a signal for transmission associated with the third audio signal; and

a transmitter communicatively coupled to the input device and adapted to transmit the signal for transmission.

15 12. The dual purpose, hand-held wireless communication device of claim 11, wherein the second receiver and the transmitter comprise mobile telephone components.



13. A cellular telephone comprising:

an audio output device;

a first receiver adapted to receive radio broadcast transmissions and to produce a first audio signal associated with the radio broadcast transmissions;

a second receiver, adapted to receive communication information associated with a telephone conversation and to produce a second audio signal associated with the communication information associated with the telephone conversation;

an audio processing block communicatively coupled to the first receiver and the second receiver, wherein the audio processing block is adapted to selectively couple one of the first audio signal and the second audio signal to the audio output device;

an input device adapted to receive a third audio signal and to produce a signal for transmission associated with the third audio signal;

a transmitter communicatively coupled to the input device and adapted to transmit the signal for transmission;

at least one antenna operatively coupled to any of the first receiver and the second receiver;

at least one impedance matching network coupling any of the at least one antenna to at least one of the first receiver and the second receiver; and

a display adapted to display any of a frequency to which the first receiver is tuned or telephone information for the second receiver.

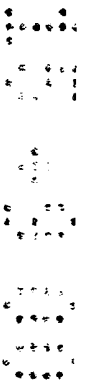



Application No: GB 0022550.8
 Claims searched: All

Examiner: Gareth Griffiths
 Date of search: 30 May 2001

Patents Act 1977
Search Report under Section 17

Databases searched:

UK Patent Office collections, including GB, EP, WO & US patent specifications, in:
 UK CI (Ed.S): H4L (LECY, LEP, LESF)
 Int CI (Ed.7): H04B 1/38, H04Q 7/32
 Other: Online Databases: WPI, EPODOC, JAPIO

Documents considered to be relevant:

Category	Identity of document and relevant passage	Relevant to claims
X	WO96/39752 A1 (ERICSSON) p.17 line 9 - p.22 line 25 & p.25 line 7 - p.26 line 15	1-13
X	US5991637 (MACK) whole document	1-13
X	US5890071 (SHIMANUKI) col.1 line 42 - col.2 line 22	1-13
X	JP080084172 A (SANYO) see abstract	1-13
X	JP040343532 A (SONY) see abstract	1-4, 6-13

X	Document indicating lack of novelty or inventive step	A	Document indicating technological background and/or state of the art.
Y	Document indicating lack of inventive step if combined with one or more other documents of same category.	P	Document published on or after the declared priority date but before the filing date of this invention.
&	Member of the same patent family	E	Patent document published on or after, but with priority date earlier than, the filing date of this application.