



(19) **United States**

(12) **Patent Application Publication**  
**Wang**

(10) **Pub. No.: US 2014/0098366 A1**

(43) **Pub. Date: Apr. 10, 2014**

(54) **SMART IV BAG WITH OPTICAL IV DRUG IDENTIFICATION TAG**

(52) **U.S. Cl.**  
CPC .... *A61J 1/12* (2013.01); *G01J 3/42* (2013.01);  
*G01J 3/44* (2013.01); *G01J 3/4406* (2013.01)  
USPC ..... **356/301**; 356/300; 250/458.1

(71) Applicant: **BWT Property, Inc.**, Newark, DE (US)

(72) Inventor: **Sean Xiaolu Wang**, Wilmington, DE (US)

(73) Assignee: **BWT Property, Inc.**, Newark, DE (US)

(21) Appl. No.: **14/047,083**

(22) Filed: **Oct. 7, 2013**

**Related U.S. Application Data**

(60) Provisional application No. 61/711,291, filed on Oct. 9, 2012.

**Publication Classification**

(51) **Int. Cl.**  
*A61J 1/12* (2006.01)  
*G01J 3/44* (2006.01)  
*G01J 3/42* (2006.01)

(57) **ABSTRACT**

This invention relates to a smart IV bag with a structurally integrated optical tag for IV drug identification and monitoring. The optical tag comprises a flow cell with a fluid channel in communication with the IV bag to sample a portion of the IV fluid onto an optical surface embedded in the flow cell. The optical surface causes a light beam to interact with the sampled IV fluid to produce a spectroscopic signal. The spectroscopic signal is then analyzed to obtain the content and concentration information of the IV fluid. Unlike traditional IV bag labels, the optical tag provides real-time, in-situ monitoring of IV fluid content and concentration, which greatly reduces the risk of mislabeling induced IV error.

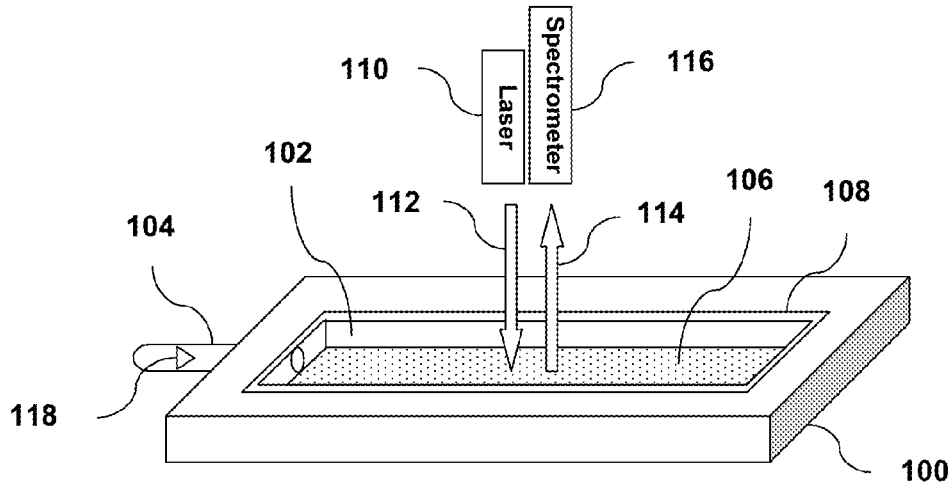

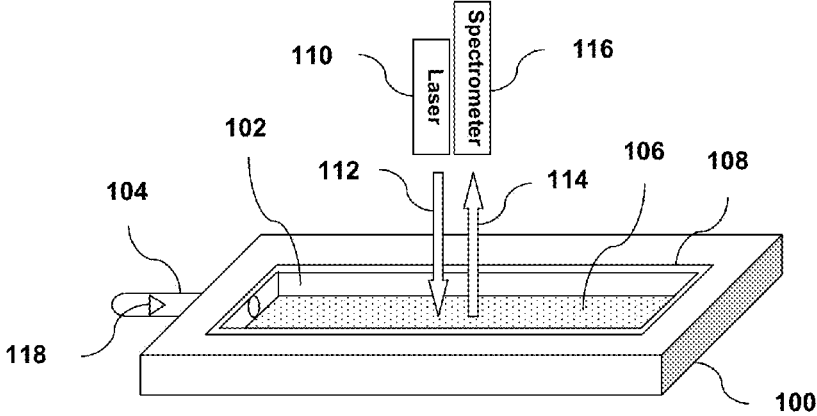

FIG. 1

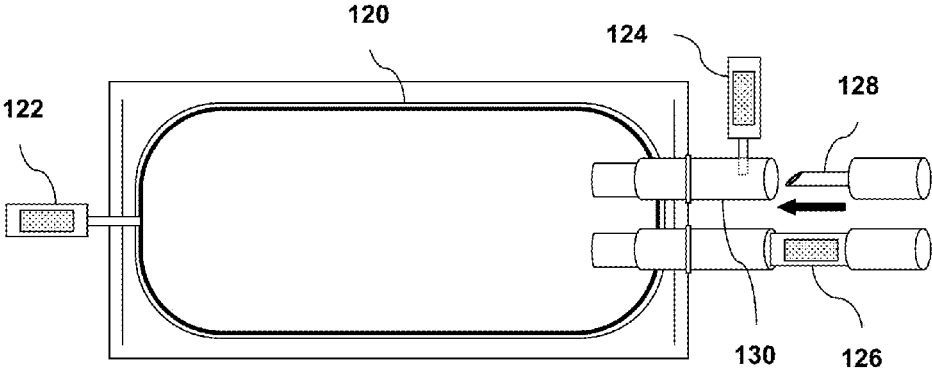

FIG. 2

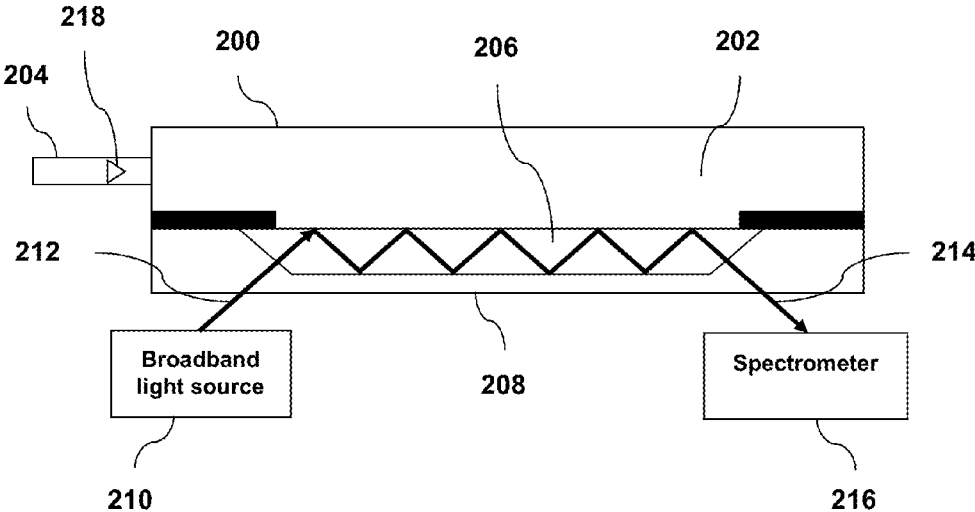

FIG. 3

## SMART IV BAG WITH OPTICAL IV DRUG IDENTIFICATION TAG

### REFERENCE TO RELATED APPLICATION

[0001] This application claims an invention which was disclosed in Provisional Patent Application No. 61/711,291, filed Oct. 09, 2012, entitled "SMART IV BAG WITH OPTICAL IV DRUG IDENTIFICATION TAG". The benefit under 35 USC §119(e) of the above mentioned United States Provisional Applications is hereby claimed, and the aforementioned applications are hereby incorporated herein by reference.

### FIELD OF THE INVENTION

[0002] This invention generally relates to an IV bag, more specifically to a smart IV bag with an optical IV drug identification tag.

### BACKGROUND

[0003] Intravenous (IV) therapy is the process of administering medication directly into a patient's vein. IV drug delivery is one of the most powerful routes to administer drugs. Unfortunately, it is also one of the most common reasons for medication error, accounting for up to 35 percent that result in significant harm. Common IV errors include: (a) wrong drug administered; (b) improper timing of administration; (c) wrong dosage amount; (d) improper injection of drug; (e) dangerous combination of drugs administered; and (f) defective IV pump or valve. There thus exists a need to rapidly identify and verify the chemical content of the IV fluid to ensure the correct drug and dosage to be delivered to the right patient.

### SUMMARY OF THE INVENTION

[0004] It is the overall goal of the present invention to provide a smart IV bag with a structurally integrated optical tag for IV drug identification and monitoring. The optical tag comprises a flow cell with a fluid channel in communication with the IV bag to sample a portion of the IV fluid onto an optical surface embedded in the flow cell. The optical surface causes a light beam to interact with the sampled IV fluid to produce a spectroscopic signal. The spectroscopic signal is then analyzed by an optical spectrometer to obtain the content and concentration information of the IV fluid. Unlike traditional IV bag labels, the optical tag provides real-time, in-situ monitoring of IV fluid content and concentration, which greatly reduces the risk of mislabeling induced IV error.

### BRIEF DESCRIPTION OF THE FIGURES

[0005] The accompanying figures, where like reference numerals refer to identical or functionally similar elements throughout the separate views and which together with the detailed description below are incorporated in and form part of the specification, serve to further illustrate various embodiments and to explain various principles and advantages all in accordance with the present invention.

[0006] FIG. 1 illustrates one exemplary optical IV drug identification tag based on surface enhanced Raman spectroscopy (SERS);

[0007] FIG. 2 illustrates a smart IV bag with structurally integrated SERS tags; and

[0008] FIG. 3 illustrates another exemplary optical IV drug identification tag based on attenuated total reflection (ATR) absorption spectroscopy.

[0009] Skilled artisans will appreciate that elements in the figures are illustrated for simplicity and clarity and have not necessarily been drawn to scale. For example, the dimensions of some of the elements in the figures may be exaggerated relative to other elements to help to improve understanding of embodiments of the present invention.

### DETAILED DESCRIPTION

[0010] Before describing in detail embodiments that are in accordance with the present invention, it should be observed that the embodiments reside primarily in combinations of method steps and apparatus components related to a smart IV bag with optical IV drug identification tag. Accordingly, the apparatus components and method steps have been represented where appropriate by conventional symbols in the drawings, showing only those specific details that are pertinent to understanding the embodiments of the present invention so as not to obscure the disclosure with details that will be readily apparent to those of ordinary skill in the art having the benefit of the description herein.

[0011] In this document, relational terms such as first and second, top and bottom, and the like may be used solely to distinguish one entity or action from another entity or action without necessarily requiring or implying any actual such relationship or order between such entities or actions. The terms "comprises," "comprising," or any other variation thereof, are intended to cover a non-exclusive inclusion, such that a process, method, article, or apparatus that comprises a list of elements does not include only those elements but may include other elements not expressly listed or inherent to such process, method, article, or apparatus. An element preceded by "comprises . . . a" does not, without more constraints, preclude the existence of additional identical elements in the process, method, article, or apparatus that comprises the element.

[0012] FIG. 1 illustrates one exemplary optical IV drug identification tag based on surface enhanced Raman spectroscopy (SERS). The SERS based optical tag 100 comprises a flow cell 102 with a flexible tube 104. The tube 104 can be connected to an IV bag to sample a portion of the IV fluid into the flow cell 102. A SERS active surface 106 is embedded in the flow cell 102 to receive the IV fluid sample. The SERS tag 100 further comprises a transparent window 108 for transmitting excitation light 112, preferably produced by a laser light source 110, to the SERS active surface 106. The laser light 112 excites a Raman scattering signal 114 from the IV fluid in close proximity to the SERS active surface 106. The Raman scattering signal 114 is then delivered into an optical spectrometer 116 for spectroscopic analysis. The SERS active surface 106 is preferably a roughened metal surface with nanostructures, which greatly enhance the intensity of the Raman scattering signal 114 through the excitation of surface plasmons. Other optical nano-structures such as surface gratings can be formed on the active surface 106 through a lithography process to further enhance the optical signal.

[0013] The SERS tag 100 further comprises a valve 118 mounted in the flexible tube 104, which seals the fluid channel to the flow cell 102. Before IV drug delivery, the practitioner can break open the valve 118 such that the IV fluid is delivered to the SERS active surface 106 for performing Raman spectroscopy analysis. The valve 118 can be made as

a one-directional valve such that the IV fluid can only flow from the IV bag into the flow cell to avoid any possible contamination to the IV fluid. In addition, a filtration member may be embedded in the tube **104** to remove certain chemical contents of the IV fluid such that only the specific IV drug can reach the SERS active surface **106** to be measured thereof.

**[0014]** FIG. 2 illustrates a smart IV bag **120** with structurally integrated SERS tags **122**, **124**, and **126**, all having similar construction as the SERS tag **100** in FIG. 1. In the first approach, the SERS tag **122** is connected to the bottom of the IV bag **120** through a flexible tube. The fluid channel in the flexible tube is sealed by a valve. Before IV drug delivery, the practitioner presses or snaps the flexible tube such that the sealing valve is broken open to lead the IV fluid to the SERS active surface. Raman spectroscopy analysis is then performed through the transparent window of the SERS tag to verify the chemical content and concentration of the IV fluid. In the second approach, a sealed SERS tag **124** is mounted at the outlet of the IV bag **120**. When a needle **128** is inserted into the micro-drip tubing **130**, it will break open the fluid channel to the SERS tag such that Raman spectroscopy analysis can be performed on the IV fluid. In the third approach, the SERS tag **126** comprises two flexible tubes. One functions as the input fluid channel and the other functions as the output fluid channel. Thus the SERS tag **126** can be mounted in the path of the IV fluid for continuously on-line monitoring.

**[0015]** The optical tag of the present invention does not perturb the IV fluid and can be used for single measurement or continuous monitoring. Unlike traditional IV bag labels, the SERS tag provides real-time, in-situ monitoring of IV fluid content and concentration. This feature greatly reduces the risk of mislabeling induced IV error.

**[0016]** In a slight variation of the present embodiment, the SERS active surface **106** of the optical tag **100** further comprises immobilized antibodies which can bind with a specific type of analytes in the IV fluid and bring them to the proximity of the SERS active surface **106** for performing Raman spectroscopic analysis. In addition, the SERS active surface **106** may incorporate fluorescence quenching molecules for suppressing the fluorescence emission of the IV drug such that a high fidelity SERS spectrum can be acquired.

**[0017]** FIG. 3 illustrates another embodiment of the optical IV drug identification tag, which utilizes an attenuated total reflection (ATR) surface to measure the absorption spectrum of the IV fluid. Similar to the SERS based optical tag of FIG. 1, the ATR based optical tag **200** comprises a flow cell **202** with a flexible tube **204**. The tube **204** can be connected to an IV bag to sample a portion of the IV fluid into the flow cell **202**. The ATR member **206** comprises a crystal (or other high refractive index optical medium) with two parallel surfaces. One surface is exposed to the IV fluid sample. A light beam **212** from a broadband light source **210** is directed onto the ATR member **206** through a transparent window **208**. The incident angle of the light beam **212** is controlled in such a way that the light beam **212** is totally internally reflected at the surface of the crystal, creating an evanescent wave that extends into the IV fluid sample in proximity to the surface of the crystal. The evanescent wave is absorbed at the absorption bands of the IV fluid. The attenuated light beam **214** is then passed through the optical window **208** to an optical spectrometer **216** for spectral analysis. The obtained absorption spectrum of the IV fluid reveals its chemical content and concentration. The light beam **212** is reflected multiple times between the two surfaces of the crystal, which greatly

increases the path length of the evanescent wave in the IV fluid. This helps to increase the extinction ratio of the obtained absorption spectrum. The ATR based optical tag **200** may further comprise a valve **218** as well as a filtration member (not shown) to control the flow of the IV fluid and the chemical content of the IV fluid sample that enters the flow cell **202**. The ATR tag **200** can be structurally integrated with an IV bag in similar manners as shown in FIG. 2.

**[0018]** In a slight variation of the present embodiment, the ATR member **206** is a modified optical waveguide such as a tapered optical fiber made of glass or plastic material. The light at the tapered region of the optical fiber propagates as an evanescent wave, which interacts with the IV fluid to produce an absorption spectrum of the IV fluid.

**[0019]** In yet another variation of the present invention, the optical tag comprises a fluorescence active surface, e.g. a dielectric grating deposited on a gold film to enhance a fluorescence emission of the IV fluid sample. The fluorescence spectrum of the IV fluid is then analyzed to obtain the content and concentration information of the IV drug.

**[0020]** In yet another variation of the present invention, the optical tag comprises an optical surface which selectively reflects certain wavelength bands in the optical spectrum for facilitating the trans-reflectance or absorption spectrum measurement of the IV fluid.

**[0021]** In the foregoing specification, specific embodiments of the present invention have been described. However, one of ordinary skill in the art appreciates that various modifications and changes can be made without departing from the scope of the present invention as set forth in the claims below. Accordingly, the specification and figures are to be regarded in an illustrative rather than a restrictive sense, and all such modifications are intended to be included within the scope of present invention. The benefits, advantages, solutions to problems, and any element(s) that may cause any benefit, advantage, or solution to occur or become more pronounced are not to be construed as a critical, required, or essential features or elements of any or all the claims. The invention is defined solely by the appended claims including any amendments made during the pendency of this application and all equivalents of those claims as issued.

What is claimed is:

1. An intravenous (IV) fluid container with pre-filled IV fluid for IV therapy, said IV fluid container comprising a structurally integrated optical IV drug identification tag, said optical IV drug identification tag comprising: a flow cell with a fluid channel in communication with said IV fluid container to sample a portion of the IV fluid; and an optical surface embedded in said flow cell, said optical surface is configured to receive said portion of the IV fluid and cause a light beam to interact with said portion of the IV fluid to produce a spectroscopic signal containing a content and concentration information of the IV fluid.

2. The IV fluid container of claim 1, wherein said optical surface is a surface enhanced Raman spectroscopy (SERS) active surface and said spectroscopic signal is a Raman scattering signal.

3. The IV fluid container of claim 1, wherein said optical surface is a fluorescence active surface and said spectroscopic signal is a fluorescence signal.

4. The IV fluid container of claim 1, wherein said optical surface is an attenuated total reflection (ATR) surface and said spectroscopic signal is an absorption signal.

5. The IV fluid container of claim 1, wherein said optical IV drug identification tag further comprising a transparent window for transmitting said light beam to said optical surface.

6. The IV fluid container of claim 1, wherein said optical IV drug identification tag further comprising a breakable valve embedded in said fluid channel, wherein said breakable valve seals the IV fluid from entering said flow cell.

7. A method for identifying and monitoring the content and concentration of intravenous (IV) fluid in an IV fluid container, the method comprising the steps of:

providing an optical IV drug identification tag structurally integrated with the IV fluid container, said optical IV drug identification tag comprising a flow cell with a fluid channel in communication with said IV fluid container to sample a portion of the IV fluid, and an optical surface embedded in said flow cell to receive said portion of the IV fluid;

causing a light beam to interact with said portion of the IV fluid in proximity to said optical surface to produce a spectroscopic signal; and

measuring said spectroscopic signal to obtain a content and concentration information of the IV fluid.

8. The method of claim 7, wherein said optical surface is a surface enhanced Raman spectroscopy (SERS) active surface and said spectroscopic signal is a Raman scattering signal.

9. The method of claim 7, wherein said optical surface is a fluorescence active surface and said spectroscopic signal is a fluorescence signal.

10. The method of claim 7, wherein said optical surface is an attenuated total reflection (ATR) surface and said spectroscopic signal is an absorption signal.

11. The method of claim 7, wherein said optical IV drug identification tag further comprising a transparent window for transmitting said light beam to said optical surface.

12. The method of claim 7, wherein said optical IV drug identification tag further comprising a breakable valve embedded in said fluid channel, wherein said breakable valve seals the IV fluid from entering said flow cell.

\* \* \* \* \*