



US010483702B2

(12) **United States Patent**  
**Robinson**

(10) **Patent No.:** **US 10,483,702 B2**  
(45) **Date of Patent:** **Nov. 19, 2019**

(54) **HIGH SPEED COMMUNICATION JACK**

(71) Applicant: **Sentinel Connector Systems, Inc.**,  
York, PA (US)

(72) Inventor: **Brett D. Robinson**, Mesa, AZ (US)

(73) Assignee: **SENTINEL CONNECTOR**  
**SYSTEMS**, York, PA (US)

(\* ) Notice: Subject to any disclaimer, the term of this  
patent is extended or adjusted under 35  
U.S.C. 154(b) by 0 days.

(21) Appl. No.: **16/192,139**

(22) Filed: **Nov. 15, 2018**

(65) **Prior Publication Data**

US 2019/0089105 A1 Mar. 21, 2019

**Related U.S. Application Data**

(63) Continuation of application No. 15/146,008, filed on  
May 4, 2016, now Pat. No. 10,141,698, which is a  
continuation of application No. 14/504,088, filed on  
Oct. 1, 2014, now Pat. No. 9,337,592, which is a  
(Continued)

(51) **Int. Cl.**

**H01R 24/64** (2011.01)  
**H01R 13/6474** (2011.01)  
**H01R 13/66** (2006.01)  
**H01R 43/20** (2006.01)  
**H05K 1/02** (2006.01)  
**H05K 1/09** (2006.01)  
**H05K 1/11** (2006.01)  
**H05K 1/16** (2006.01)  
**H01R 13/6581** (2011.01)  
**H01R 107/00** (2006.01)

(52) **U.S. Cl.**

CPC ..... **H01R 24/64** (2013.01); **H01R 13/6474**  
(2013.01); **H01R 13/6625** (2013.01); **H01R**  
**43/205** (2013.01); **H05K 1/0218** (2013.01);

**H05K 1/0228** (2013.01); **H05K 1/09**  
(2013.01); **H05K 1/115** (2013.01); **H05K**  
**1/162** (2013.01); **H01R 13/6581** (2013.01);  
**H01R 13/6658** (2013.01); **H01R 2107/00**  
(2013.01); **Y10T 29/49165** (2015.01)

(58) **Field of Classification Search**

CPC ..... H01R 13/6466  
See application file for complete search history.

(56) **References Cited**

**U.S. PATENT DOCUMENTS**

6,250,968 B1 6/2001 Winings  
6,663,423 B2 12/2003 Belopolsky et al.  
7,018,242 B2 3/2006 Brown et al.  
(Continued)

**FOREIGN PATENT DOCUMENTS**

JP 2003015902 A 1/2003

**OTHER PUBLICATIONS**

International Search Report dated Mar. 22, 2013 for PCT/US2013/  
022919; 3 Pages.

*Primary Examiner* — Ross N Gushi

(57) **ABSTRACT**

A circuit board for a high speed communication jack including a rigid circuit board in the housing having a substrate, a plurality of vias extending through the substrate with each via being configured to accommodate a pin on the housing, a plurality of traces on a middle layer in the substrate, with each trace extending from a corresponding one of the plurality of vias, a first shielding layer on a first side of the middle layer in the substrate, a second shielding layer on a second side of the middle layer in the substrate, and a third shielding layer adjacent to the second shielding layer.

**10 Claims, 8 Drawing Sheets**

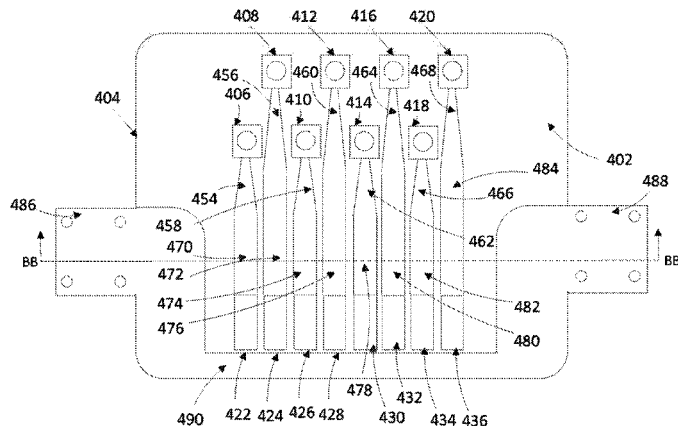
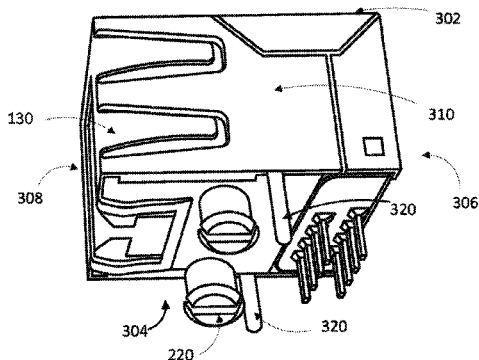

**Related U.S. Application Data**

continuation-in-part of application No. 13/739,214,  
 filed on Jan. 11, 2013, now Pat. No. 8,858,266.  
 (60) Provisional application No. 61/598,288, filed on Feb.  
 13, 2012.

8,052,483 B1 11/2011 Straka et al.  
 8,083,551 B2 12/2011 Hetzer et al.  
 8,262,415 B2 9/2012 Caveney et al.  
 8,287,317 B2 10/2012 Straka et al.  
 8,303,348 B2 11/2012 Straka et al.  
 8,435,083 B2 5/2013 Hetzer et al.  
 8,435,084 B2 5/2013 Caveney et al.  
 8,550,850 B2 10/2013 Caveney et al.  
 8,632,362 B2 1/2014 Straka et al.  
 8,632,367 B2 1/2014 Caveney  
 8,764,476 B1 7/2014 Ma

(56) **References Cited**

U.S. PATENT DOCUMENTS

7,252,554 B2	8/2007	Caveney et al.	2002/0191140 A1	12/2002	Eguchi et al.
7,357,683 B2	4/2008	Caveney et al.	2004/0116081 A1	6/2004	Crudele et al.
7,364,470 B2	4/2008	Hashim	2005/0181676 A1	8/2005	Caveney et al.
7,402,085 B2	7/2008	Hammond, Jr. et al.	2006/0121792 A1	6/2006	Hashim
7,452,246 B2	11/2008	Caveney et al.	2006/0160428 A1	7/2006	Hashim
7,544,088 B2	6/2009	Caveney et al.	2007/0015417 A1	1/2007	Caveney et al.
7,601,034 B1	10/2009	Aekins et al.	2007/0117469 A1	5/2007	Caveney et al.
7,618,296 B2	11/2009	Caveney	2007/0178772 A1	8/2007	Hashim et al.
7,670,193 B2	3/2010	Milette et al.	2007/0190863 A1	8/2007	Caveney et al.
7,736,195 B1	6/2010	Poulsen et al.	2008/0020652 A1	1/2008	Caveney et al.
7,823,281 B2	11/2010	Caveney et al.	2008/0166925 A1	7/2008	Caveney et al.
7,824,231 B2	11/2010	Marti et al.	2009/0242241 A1	10/2009	Takahashi et al.
7,837,513 B2	11/2010	Millette et al.	2010/0041278 A1	2/2010	Bopp et al.
7,850,492 B1	11/2010	Straka et al.	2011/0104933 A1	5/2011	Straka et al.
7,857,667 B1	12/2010	Wang	2012/0122352 A1	5/2012	Caveney
7,874,879 B2	1/2011	Caveney et al.	2012/0129404 A1	5/2012	Caveney et al.
7,905,753 B2	3/2011	Siev et al.	2012/0164884 A1	6/2012	Hetzer et al.
7,909,649 B2	3/2011	Laroche	2012/0184154 A1	7/2012	Straka et al.
7,914,345 B2	3/2011	Bopp et al.	2013/0210277 A1	8/2013	Robinson
7,967,645 B2	6/2011	Marti et al.	2013/0288538 A1	10/2013	Caveney et al.
8,011,972 B2	9/2011	Caveney et al.	2014/0073196 A1	3/2014	Hashim et al.
8,047,879 B2	11/2011	Hashim	2014/0154919 A1	6/2014	Straka et al.

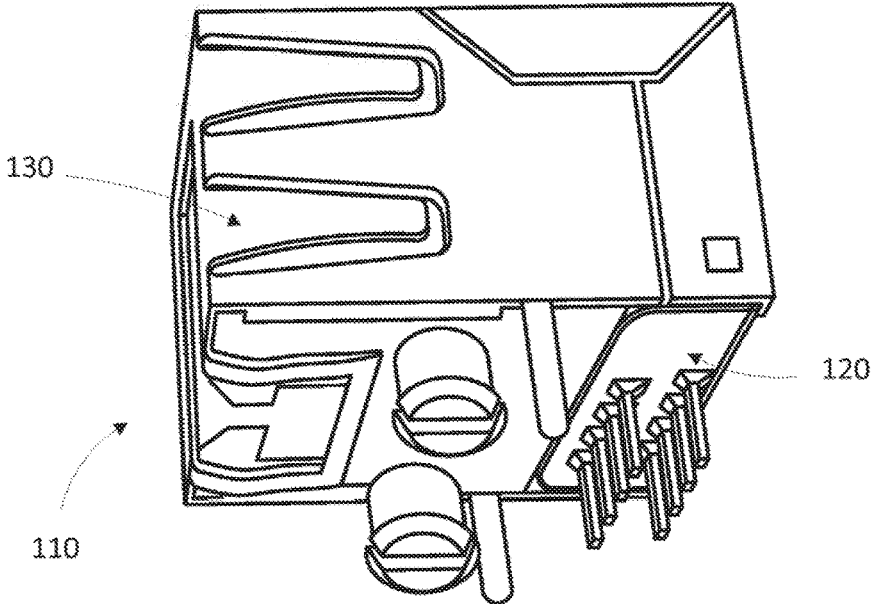

FIG. 1

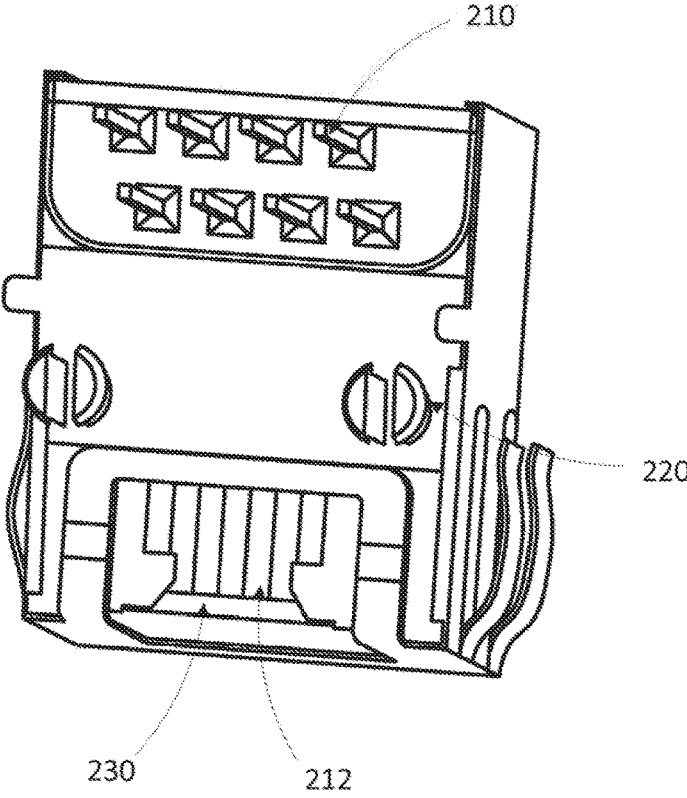

FIG. 2

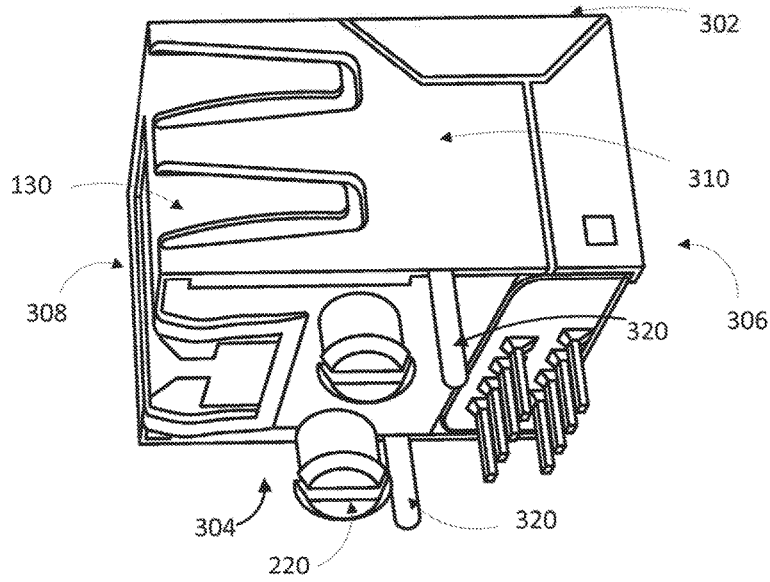

FIG. 3

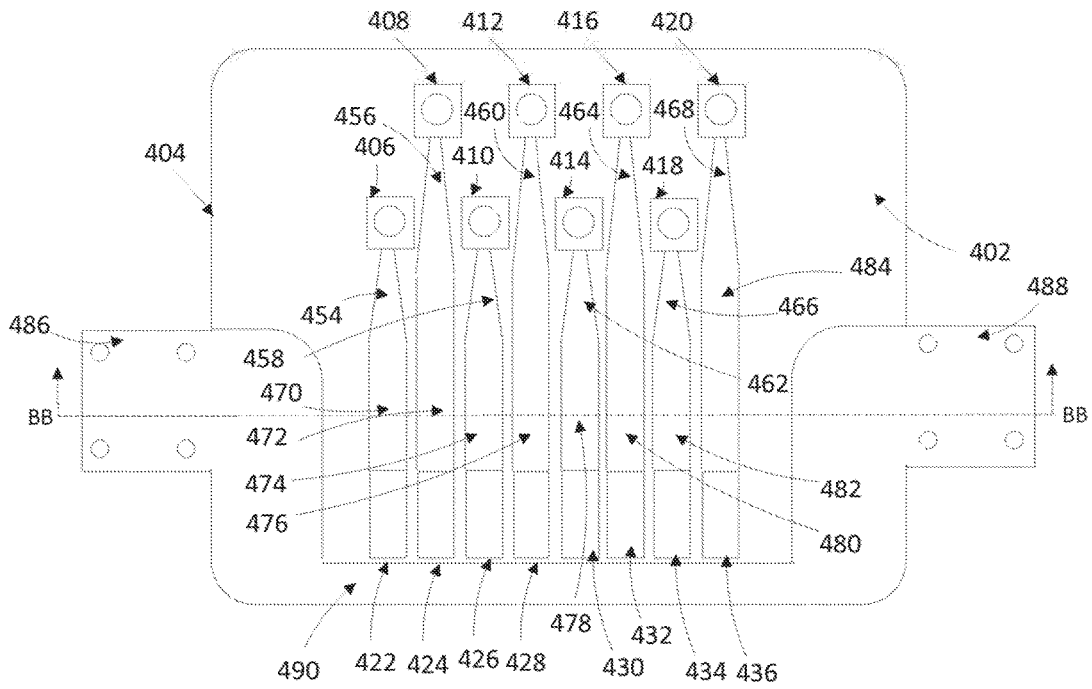

FIG. 4A

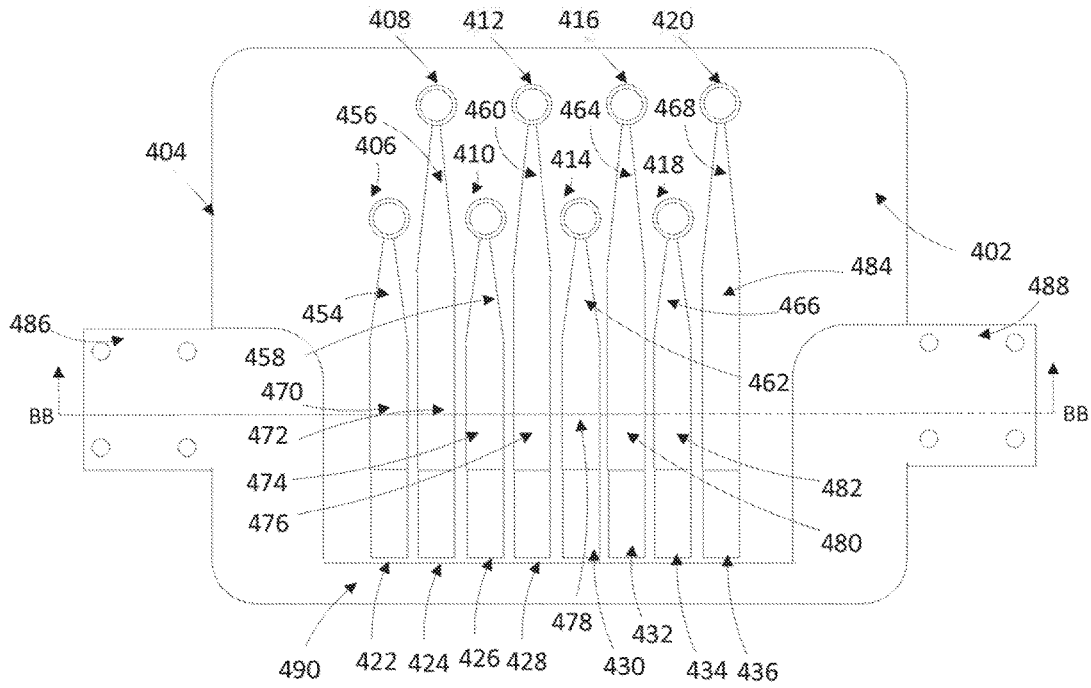

FIG. 4B

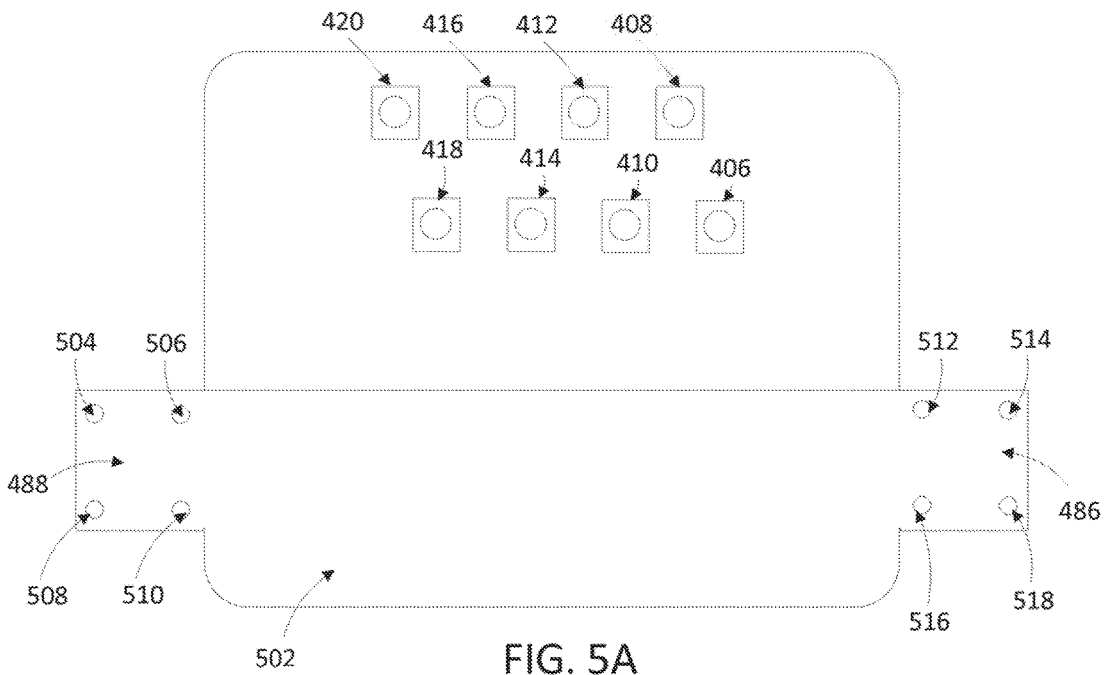

FIG. 5A

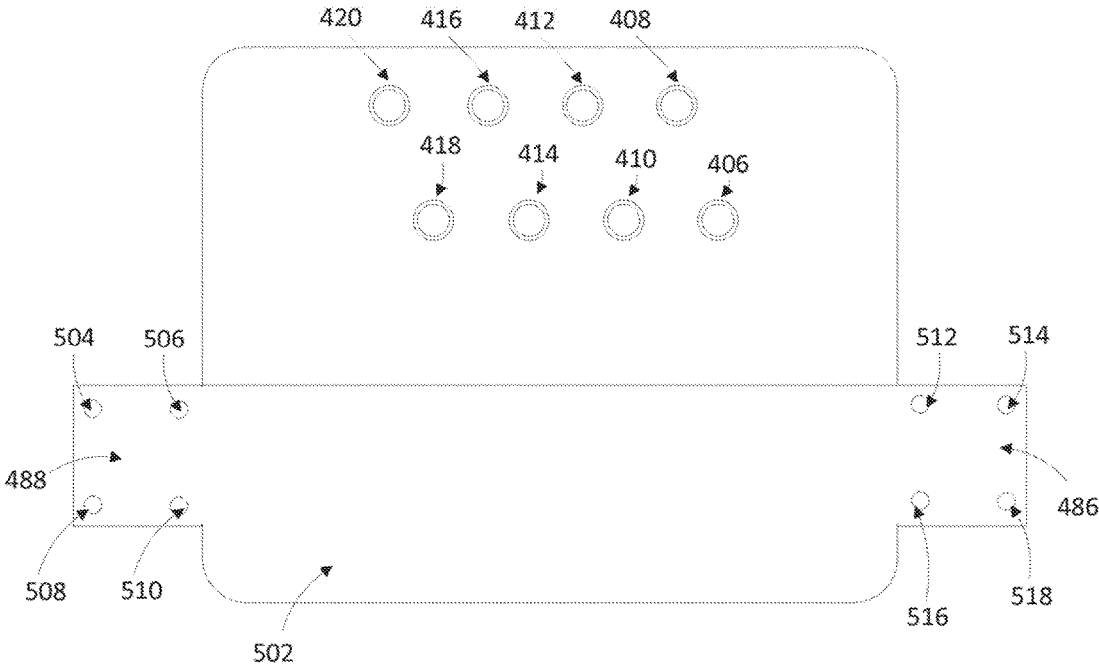

FIG. 5B

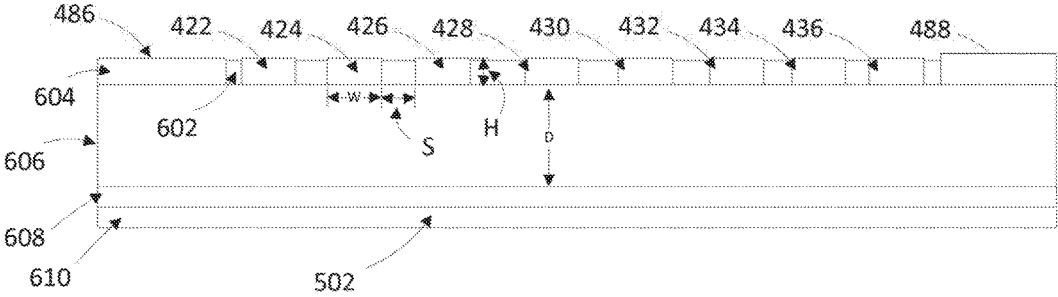

FIG. 6A

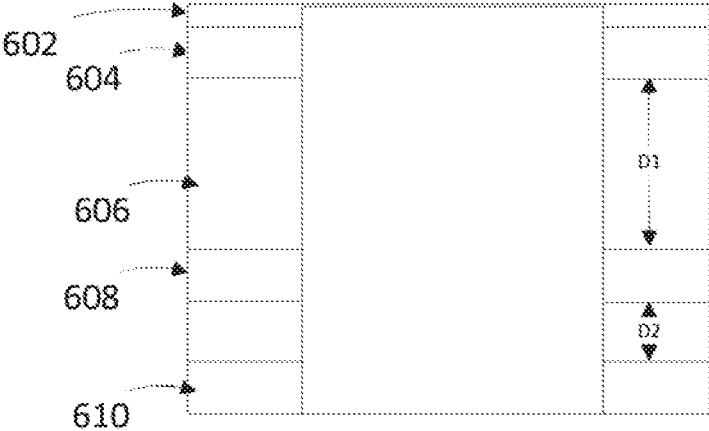

FIG. 6B

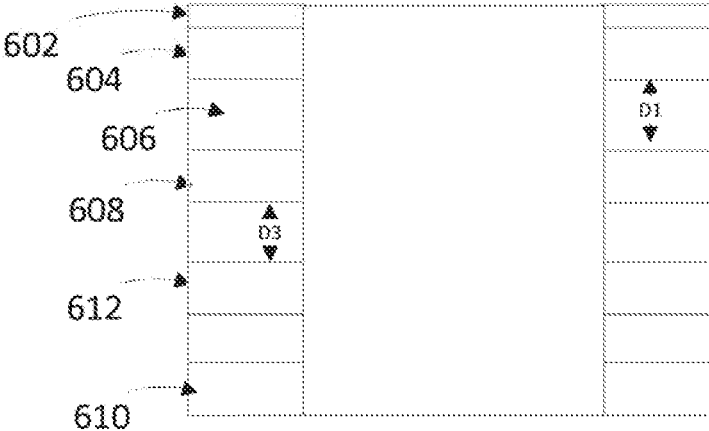

FIG. 6C

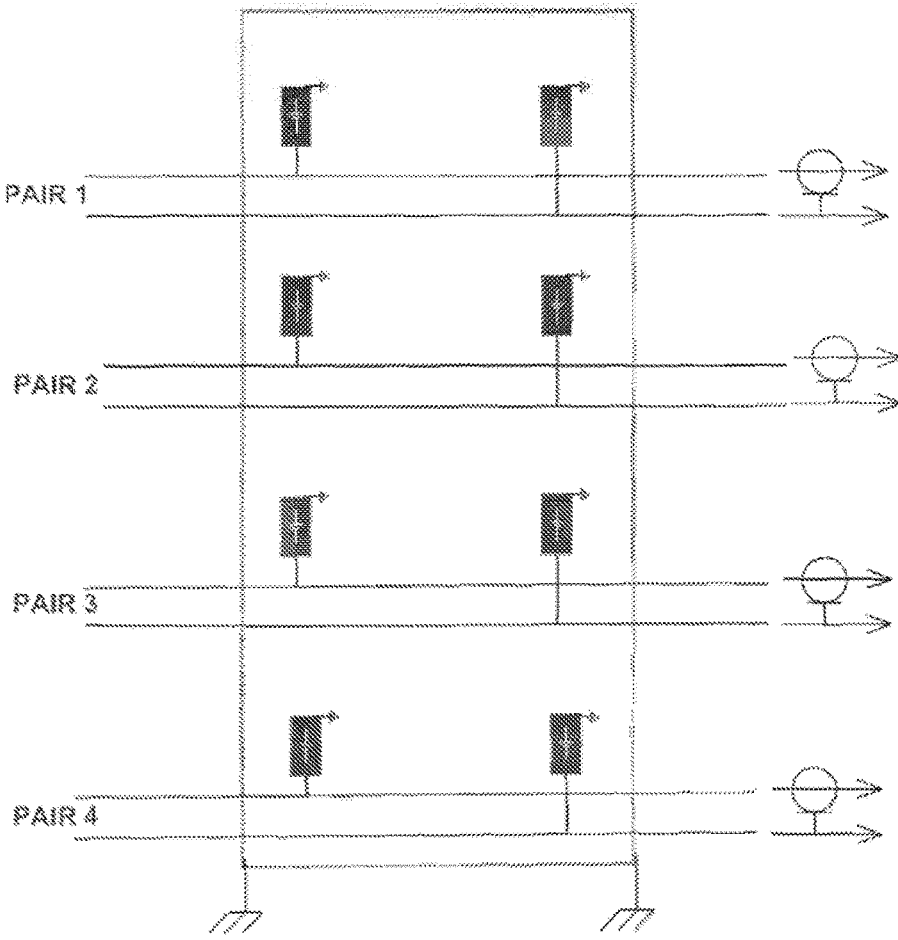

FIG. 7

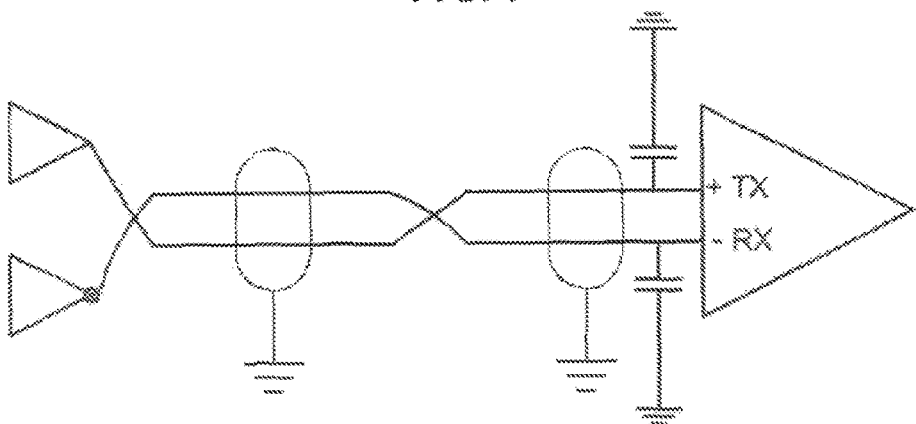

FIG. 8



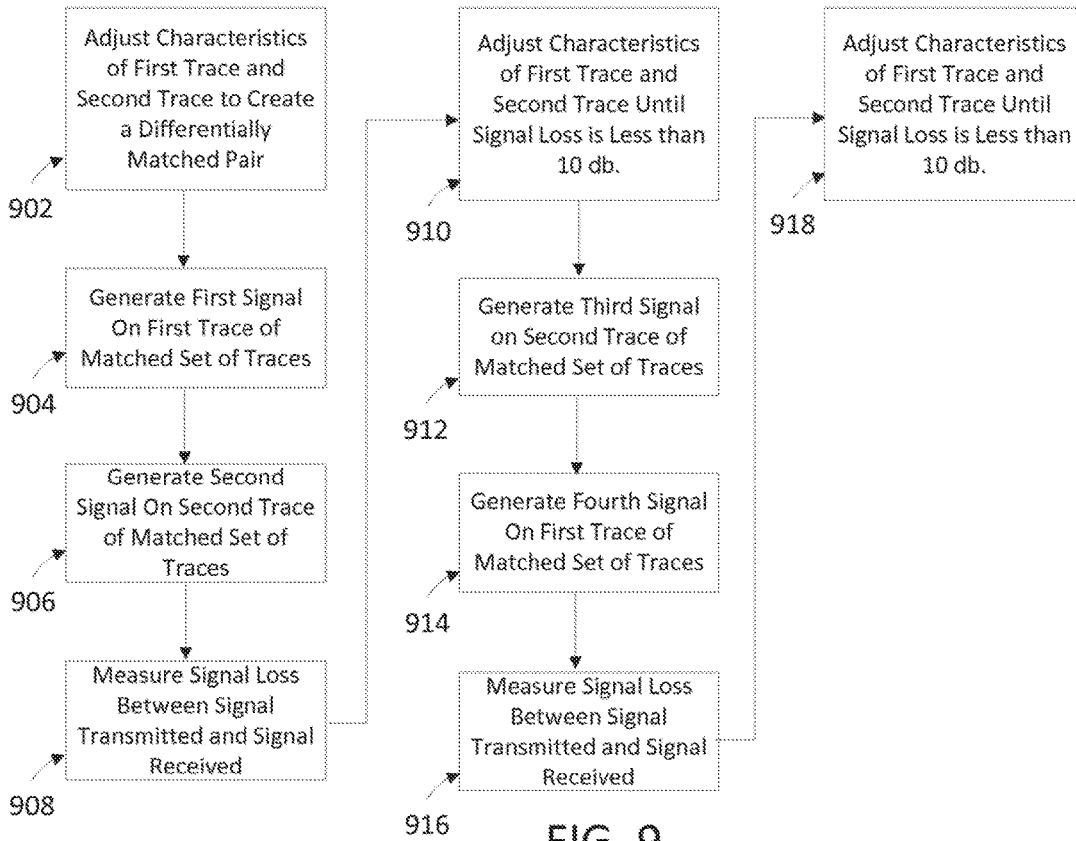

FIG. 9

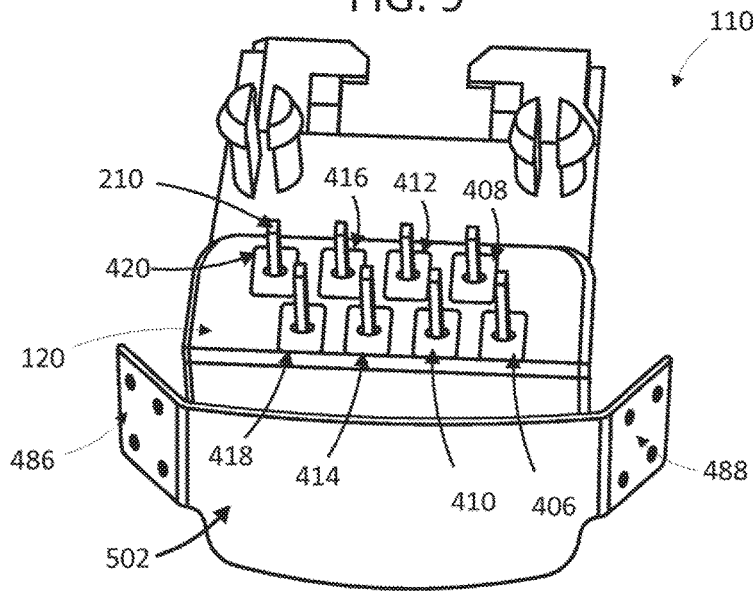

FIG. 10A

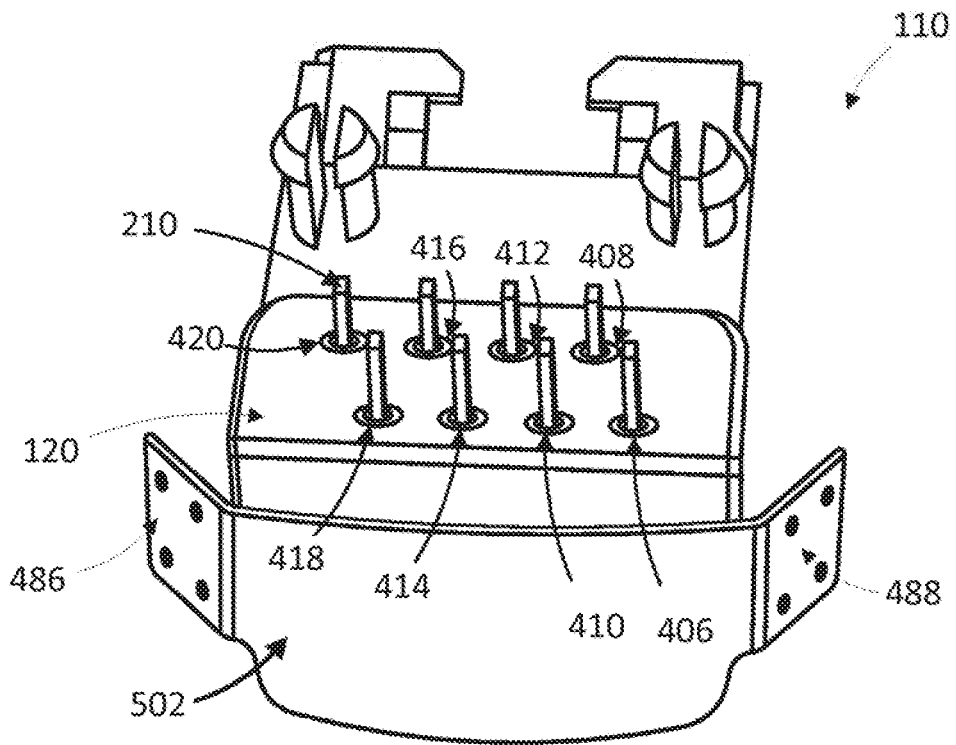

FIG. 10B

**HIGH SPEED COMMUNICATION JACK**CROSS-REFERENCE TO RELATED  
APPLICATIONS

The present disclosure is a continuation of U.S. patent application Ser. No. 15/146,008, filed May 4, 2016, which is a continuation of U.S. patent application Ser. No. 14/504,088, filed Oct. 1, 2014, now U.S. Pat. No. 9,337,592, which is a continuation in part of U.S. patent application Ser. No. 13/739,214, filed Jan. 11, 2013, now U.S. Pat. No. 8,858,266, which claims the benefit of and priority to U.S. Provisional Patent App. No. 61/598,288, filed on Feb. 13, 2012, all of which are incorporated by reference herein in their entirety.

## FIELD OF THE DISCLOSURE

The present disclosure relates to a network connection jack used to connect a network cable to a device.

## BACKGROUND OF THE DISCLOSURE

As electrical communication devices and their associated applications become more sophisticated and powerful, their ability to gather and share information with other devices also becomes more important. The proliferation of these intelligent, inter networked devices has resulted in a need for increasing data throughput capacity on the networks to which they are connected to provide the improved data rates necessary to satisfy this demand. As a result, existing communication protocol standards are constantly improved or new ones created. Nearly all of these standards require or significantly benefit, directly or indirectly, from the communication of high-definition signals over wired networks. Transmission of these high definition signals, which may have more bandwidth and, commensurately, higher frequency requirements, need to be supported in a consistent fashion. However, even as more recent versions of various standards provide for theoretically higher data rates or speeds, they are still speed limited by the current designs of certain physical components. Unfortunately, the design of such physical components is plagued by a lack of understanding of what is necessary to achieve consistent signal quality at multi-gigahertz and higher frequencies.

For example, communication jacks are used in communication devices and equipment for the connection or coupling of cables that are used to transmit and receive the electrical signals that represent the data being communicated. A registered jack (RJ) is a standardized physical interface for connecting telecommunications and data equipment. The RJ standardized physical interface includes both jack construction and wiring pattern. A commonly used RJ standardized physical interface for data equipment is the RJ45 physical network interface, also referred to as an RJ45 jack. The RJ45 jack is widely used for local area networks such as those implementing the Institute of Electrical and Electronic Engineers (IEEE) 802.3 Ethernet protocol. The RJ45 jack is described in various standards, including one that is promulgated by the American National Standards Institute (ANSI)/Telecommunications Industry Association (TIA) in ANSI/TIA-1096-A.

All electrical interface components, such as cables and jacks, including the RJ45 jack, not only resist the initial flow of electrical current, but also oppose any change to it. This property is referred to as reactance. Two relevant types of reactance are inductive reactance and capacitive reactance.

Inductive reactance may be created, for example, based on a movement of current through a cable that resists, which causes a magnetic field that induces a voltage in the cable. Capacitive reactance, on the other hand, is created by an electrostatic charge that appears when electrons from two opposing surfaces are placed close together.

To reduce or avoid any degradation of transmitted signals, the various components of a communications circuit preferably have matching impedances. If not, a load with one impedance value will reflect or echo part of a signal being carried by a cable with a different impedance level, causing signal failures. For this reason, data communication equipment designers and manufacturers, such as cable vendors, design and test their cables to verify that impedance values, as well as resistance and capacitance levels, of the cables comply with certain performance parameters. The RJ45 jack is also a significant component in nearly every communications circuit, however, jack manufacturers have not provided the same level of attention to its performance. Thus, although problems related to existing RJ45 jacks are well documented in tests and their negative impact on high frequency signal lines is understood, the industry seems reluctant to address the issues for this important component of the physical layer. Consequently, there is a need for an improved high speed communications jack.

## BRIEF SUMMARY OF THE DISCLOSURE

In one example, a high speed communication jack may include a housing including a port for accepting a plug. The port may include a plurality of pins each connected to a corresponding signal line in the plug, a shielding case surrounding the housing, and a flexible circuit board between the shielding case and the housing. The flexible circuit board may include a substrate, a plurality of vias extending through the substrate with each via being configured to accommodate a pin on the housing, a plurality of traces on a first side of the substrate, with each trace extending from a corresponding one of the plurality of vias, and a shielding plane on a second side of the substrate opposite the first side of the substrate.

In another example, when energized, each trace may be differentially matched to a second adjacent trace.

In another example, the impedance value a first trace in a matched pair of traces may be adjusted to be substantially equal to the impedance value of the second trace in the matched pair of traces.

In another example, a capacitor may be formed in each via by a trace layer and a return signal layer embedded in a dielectric layer.

In another example, a distance between the return signal layer and the trace layer may be adjusted such that the capacitor has a value of between approximately 0.1 pF and approximately 0.5 pF.

In another example, the width, height or length of each trace in matched set of traces may be adjusted such that the impedance of the first trace matches the impedance of the second trace.

In another example, a second return signal layer may be formed in the dielectric layer below the first return signal layer to form a second capacitor.

In another example, the distance between the first signal layer and second signal layer may be adjusted to adjust the value of the second capacitor between 0.1 pF and 0.5 pF.

In another example, the impedance of the first trace and second trace may be adjusted such that the traces are

matched when a first signal is transmitted on the first trace and a second signal is transmitted on the second trace.

In another example, the capacitor, trace and return signal layer may form a common mode filter with the matched set of traces.

In another example, the value of the capacitor may be adjusted such that the common mode filter prevent reflections of signals from the matched traces.

In another example, a second shielding tab on a side of the substrate may be formed opposite the first shielding.

In another example, the traces may be plated in gold.

Another example may include a high speed communication jack comprising a standard RJ45 housing a housing including a port for accepting a plug, the port including a plurality of pins each connected to a corresponding signal line in the plug. The jack may include a shielding case surrounding the housing, and a flexible circuit board between the shielding case and the housing. The flexible circuit board may include a substrate, a plurality of vias extending through the substrate with each via being configured to accommodate a pin on the housing, a plurality of traces on a first side of the substrate, with each trace extending from a corresponding one of the plurality of vias, and a shielding plane on a second side of the substrate opposite the first side of the substrate.

Another example may include a method of manufacturing a high speed communication jack using a standard RJ45 housing having a front surface, back surface, top surface, bottom surface, right surface and left surface, the housing including a plurality of pins each connected to a corresponding signal line in the plug. The method may include the steps of forming a flexible circuit board having a substrate, a plurality of vias extending through the substrate with each via being configured to accommodate a pin on the housing, a plurality of traces on a first side of the substrate, with each trace extending from a corresponding one of the plurality of vias, a shielding plane on a second side of the substrate opposite the first side of the substrate, and at least two shielding tabs on opposite ends of the flexible circuit board and connected to the electrical circuit board by a shielding trace. Inserting each via in the flexible circuit board into a corresponding pin in the housing. Bending the flexible circuit board such that a portion of the flexible circuit board having the vias is on the bottom surface of the housing and is orthogonal to the portion of the flexible circuit board having the shielding plane that is on the back portion of the housing. Bending each shielding tab such that one shielding tab is in contact with the left side surface and one shielding tab is in contact with the right side surface of the housing, and forming a shielding case over the flexible circuit board and the housing such that the shielding case is in contact with each of the shielding tabs.

Another example may include a high speed communication jack having a housing including a port for accepting a plug, the port including a plurality of pins each connected to a corresponding signal line in the plug, a shielding case surrounding the housing, and a multilayer flexible circuit board between the shielding case and the housing. The multilayer flexible circuit board may include a first layer having a plurality of traces, with each trace extending from a corresponding one of the plurality of vias, a second layer of a dielectric material on a side of the first layer opposite the traces, a third layer on a side of the second layer opposite the first layer and having a return plane made from a conductive material, a fourth layer on a side of the third layer opposite the second layer and made of a dielectric material, and a fifth layer on a side of the fourth layer opposite the third layer and

made of a conductive material. A plurality of vias may extend through the first, second, third, fourth and fifth layers, with each via being configured to accommodate a pin on the housing.

#### BRIEF DESCRIPTION OF THE DRAWINGS

FIG. 1 illustrates a high speed communications jack configured in accordance with one embodiment of the various aspects of the present disclosure that includes an RJ45 jack,

FIG. 2 illustrates a bottom perspective portion of a left side portion of the RJ45 jack of FIG. 1,

FIG. 3 illustrates a bottom and right side view of a jack shield for providing shielding for the RJ45 jack and the flexible printed circuit board of FIG. 1,

FIG. 4A illustrates a schematic representation of a top view of the front surface of the printed circuit board of FIG. 1,

FIG. 4B illustrates another embodiment of a schematic representation of a top view of the front surface of the printed circuit board of FIG. 1

FIG. 5A illustrates a schematic representation of a top view of the back surface of the printed circuit board of FIG. 4,

FIG. 5B illustrates another embodiment of a schematic representation of a top view of the back surface of the printed circuit board of FIG. 4

FIG. 6A illustrates a cross sectional view of the substrate of the printed circuit board of FIG. 4 along line BB,

FIG. 6B illustrates a cross sectional view of a via in the printed circuit board of FIG. 4,

FIG. 6C illustrates a cross sectional view of another example of a via in the printed circuit board of FIG. 4.

FIG. 7 illustrates a schematic representation an RJ45 jack having transmit and receiving cable pairs matched and balanced to one another,

FIG. 8 illustrates a schematic representation of a differentially balanced pair of signal lines,

FIG. 9 illustrates a schematic representation of the process used to differentially balance two traces in FIG. 4 based on a first signal and a second signal,

FIG. 10A illustrates a rear perspective view of the RJ45 jack of FIG. 1 with the shield removed;

FIG. 10B illustrates a rear perspective view of another embodiment of the RJ45 jack of FIG. 1 with the shield removed.

#### DETAILED DESCRIPTION OF THE DISCLOSURE

FIG. 1 illustrates a high speed communications jack configured in accordance with one embodiment of the various aspects of the present disclosure that includes an RJ45 jack **110**, a flexible printed circuit board (PCB) **120**, and a jack shield **130**. As described herein, in accordance with various aspects of this disclosure, the flexible PCB **120** provides a balanced, radio frequency tuned circuit that may be directly soldered onto each pin of the RJ45 jack **110**, while the jack shield **130** provides shielding for the RJ45 jack **110** and the flexible PCB **120**, as well as functioning as a chassis ground. In combination, the RJ45 jack **110**, the flexible PCB **120**, and the jack shield **130** may provide functionality similar to a tuned waveguide and a tube through which communication signals may be transmitted, where an energy portion of the communication signal travels outside the tube through jack shield **130**; and an information

portion of the communication signal travels within the tube along the non-resistive gold wire; thereby allowing for high speed data signal speeds to be obtained. For example, it is envisioned that data speeds of 40 gigabits (Gbs) and beyond may be supported.

Although an RJ 45 communication jack is used below, the present communication jack is not limited to RJ 45 communication jacks and may be used in any type of high speed communication jack including, all class of modular RJ type connectors, Universal Serial Bus (USB) connectors and jacks, Firewire (1394) connectors and jacks, HDMI (High-Definition Multimedia Interface) connectors and jacks, D-subminiature type connectors and jacks, ribbon type connectors or jacks, or any other connector or jack receiving a high speed communication signal.

In various aspects of this disclosure, the various pins and traces disclosed herein may be composed of any suitable conductive elements such as gold, silver, or copper, or alloys and combinations of any suitable conductive elements. For example, the set of pins and plug contacts of the RJ45 jack **110** may include gold-plated copper pins or wires, while the set of traces of the flexible PCB **120** may include gold-plated copper paths. The gold plating is used to provide a corrosion-resistant electrically conductive layer on copper, which is normally a material that oxidizes easily. Alternatively, a layer of a suitable barrier metal, such as nickel, may be deposited on the copper substrate before the gold plating is applied. The layer of nickel may improve the wear resistance of the gold plating by providing mechanical backing for the gold layer. The layer of nickel may also reduce the impact of pores that may be present in the gold layer. At higher frequencies, gold plating may not only reduce signal loss, but may also increase the bandwidth from the skin effect where current density is highest on the outside edges of a conductor. In contrast, use of nickel alone will result in signal degradation at higher frequencies due to the same effect. Thus, higher speeds may not be achieved in RJ45 jacks that use nickel plating alone. For example, a pin or trace plated only in nickel may have its useful signal length shortened as much as three times once signals enter the GHz range although some benefits of using gold plating over the copper path has been described herein, other conductive elements may be used to plate the copper paths. For example, platinum, which is also non-reactive but a good conductor, may be used instead of gold to plate the copper paths.

Each of the major components of the high speed communications jack, namely the RJ45 jack **110**, the flexible printed circuit board (PCB) **120**, and the jack shield **130** will be described briefly herein before a discussion of how these components interoperate to achieve support for high speed communications is provided.

FIG. 2 illustrates a bottom perspective view of a front portion of the RJ45 jack **110** of FIG. 1, where it may be seen that a plug opening **230** is provided for inserting a plug (not shown). The plug opening **230** may be configured to receive the plug to couple contacts on the plug to a set of plug contacts **212** in the RJ45 jack **110**. The plug may be an RJ45 8 Position 8 Contact (8P8C) modular plug. The set of plug contacts **212** are formed into a set of pins **210** configured to be attached to a communication circuit on a circuit board. For example, the RJ45 jack **110** may be mounted to a circuit board of a network switch device through the use of a pair of posts **220**, and then the set of pins **210** may be soldered onto respective contact pads on the circuit board of the device. By itself, a jack similar to the RJ45 jack **110** as illustrated in FIG. 2 provides basic connectivity between a

plug of an RJ45 cable and the circuit board of a device into which the jack is integrated. However, that jack is not designed to handle communication frequencies needed for high speed communications. The RJ45 jack **110**, as configured in accordance with various aspects of the disclosed approach as described herein, may be integrated with other components such as the jack shielding **130** and the flexible PCB **120** so that it may be used to communicate at higher speeds without interference from transient signals.

FIG. 3 illustrates a bottom and right side view of a jack shield for providing shielding for the RJ45 jack **110** and the flexible PCB **120**. The jack shield **130** includes a top portion **302**, a bottom portion **304**, a back portion **306**, a front portion **308**, a left side portion (not shown but substantially identical to the right side portion) and a right side portion **310**. In order to provide desired shielding properties, in one embodiment of the present disclosure the jack shield **130** may include a conductive material such as, but not limited to, steel, copper, or any other conductive material. A pair of tabs **320** on both the right side **310** and the left side (not shown) of the jack shield **130**, near the bottom portion **304**, may be used to ground and secure the jack shield **130** to a circuit board within a device (not shown). For example, the pair of tabs **320** on the jack shield **130** may be inserted into a pair of matched mounting holes on the circuit board, and soldered thereon.

FIG. 4A illustrates a schematic representation of a top view of the front surface of the PCB **120** of the RJ45 jack. The PCB **120** includes a multi-layer substrate **402** made of a dielectric material incorporating strip-line flex or equivalent technology. The edge of the substrate **402** is surrounded by a protective layer **404**. The protective layer **404** is made of a non-conducting material such as, but not limited to, plastic or a flexible solder mask. The front surface of the substrate **402** includes a plurality of vias **406**, **408**, **410**, **412**, **414**, **416**, **418** and **420** made through the substrate **402**. Each via **406**, **408**, **410**, **412**, **414**, **416**, **418** and **420** passes through the substrate **402** and is sized to accommodate a pin **210**. The area surrounding each via **406**, **408**, **410**, **412**, **414**, **416**, **418** and **420** is coated with a conductive material, such as gold. The coating surrounding each via **406**, **408**, **410**, **412**, **414**, **416**, **418** and **420** may be substantially square shaped or substantially rectangular shaped. In another embodiment, depicted in FIG. 4B, the coating surrounding each via **406**, **408**, **410**, **412**, **414**, **416**, **418** and **420** may be substantially circular shaped. By making the coating circular shaped, the interference between adjacent vias **406**, **408**, **410**, **412**, **414**, **416**, **418** and **420** is reduced.

A plurality of traces **422**, **424**, **426**, **428**, **430**, **432**, **434** and **436** extend from each via **406**, **408**, **410**, **412**, **414**, **416**, **418** and **420** towards an end of the PCB **120**. Each trace **422**, **424**, **426**, **428**, **430**, **432**, **434** and **436** is made from a conductive material including copper or gold. In one embodiment, a nickel layer is formed on the substrate **402** and a gold layer is formed on the nickel layer to form each trace **422**, **424**, **426**, **428**, **430**, **432**, **434** and **436**. Each trace **422**, **424**, **426**, **428**, **430**, **432**, **434** and **436** extends towards a back end of the PCB **120** until the trace **422**, **424**, **426**, **428**, **430**, **432**, **434** or **436** reaches a shielding trace layer **490** near an edge of the PCB **120** opposite the vias **406**, **408**, **410**, **412**, **414**, **416**, **418** and **420**. Each trace **422**, **424**, **426**, **428**, **430**, **432**, **434** and **436** includes a first portion **454**, **456**, **458**, **460**, **462**, **464**, **466** and **468** adjacent to a second portion **470**, **472**, **474**, **476**, **478**, **480**, **482** and **484** with each second portion **470**, **472**, **474**, **476**, **478**, **480**, **482** and **484** extending to the shielding trace layer **490** without contacting the shielding trace layer **490**. Each first portion **454**, **456**, **458**, **460**, **462**,

464, 466 and 468 tapers from the respective second portion 470, 472, 474, 476, 478, 480, 482 and 484 towards a respective via 406, 408, 410, 412, 414, 416, 418 or 420. Each second portion 470, 472, 474, 476, 478, 480, 482 and 484 has a length that varies depending on the trace 422, 424, 426, 428, 430, 432, 434 or 436.

Two shielding tabs 486 and 488 are positioned on opposite edges of the PCB 120. Each shielding tab 486 and 488 is made of a substrate covered in a conductive material for example, gold or copper. The shielding tabs 486 and 488 are electrically connected by the shield trace layer 490 on the substrate 402 that extends between the shielding tabs 486 and 488 and is positioned between the second portions 470, 472, 474, 476, 478, 480, 482 and 484 of each trace 422, 424, 426, 428, 430, 432, 434 and 436 and the edge of the PCB 120 opposite the vias 406, 408, 410, 412, 414, 416, 418 and 420.

FIG. 5A illustrates a schematic representation of a top view of the back surface of the printed circuit board of FIG. 4A. The back surface includes the vias 406, 408, 410, 412, 414, 416, 418 and 420, the shielding tabs 486 and 488, and a shielding trace layer 502 extending between the back surfaces of each shielding tab 486 and 488. The shielding trace layer 502 covers the portion of the back surface of the PCB 120 between the shielding tabs 486 and 488. The shielding tabs 486 and 488 include return vias 504, 506, 508, 510, 512, 514, 516 and 518 which pass through the substrate 402 connecting the shielding trace layer 490 and the shielding trace layer 502. FIG. 5B depicts another embodiment of a top view of the back surface of the printed circuit board of FIG. 4B.

FIG. 6A illustrates a cross-section view of the multi-layer substrate 402 in the PCB 120 along line BB of FIG. 4. A first layer 602 of the multi-layer substrate 402 includes a solder mask portion, made from a material such as PSR9000FST Flexible Solder Mask. A second layer 604 is formed under the top layer and includes each of the traces 422, 424, 426, 428, 430, 432, 434 and 436. Each trace 422, 424, 426, 428, 430, 432, 434 and 436 has a length (L), a height (H) and a width (W), and is separated from an adjacent trace by a distance (S). The length (L) of each trace is the length the trace extends along the surface of the flexible circuit board 120 from the edge of its respective via 406, 408, 410, 412, 414, 416, 418 and 420 to shielding trace layer 490.

Each trace 422, 424, 426, 428, 430, 432, 434 and 436 extends through the first layer 602 such that each trace 422, 424, 426, 428, 430, 432, 434 and 436 is not covered by the flexible solder mask. Shield trace layer 490 is also formed over a portion of the second layer 604 with the shield trace layer 490 extending through the first layer 602. A third dielectric layer 606 is formed below the second layer 604. The third layer 606 has a depth (D) of between approximately 0.002 mils to approximately 0.005 mils, and is made from a material having a dielectric constant greater than 3.0 such as, but not limited to RO XT8100, Rogerson Material, or any other material capable of isolating a high frequency electrical signal.

A fourth layer 608 is formed below the third layer 606 with the fourth layer 608 including a signal return portion and a shield trace portion 502. Both the signal return portion and the shield trace portion 502 are made of a conductive material, preferably gold or copper. A fifth layer 610 is formed on the fourth layer 608 with the fifth layer 610 having a flexible solder mask portion and a shielding trace layer 502 portion. The flexible solder mask portion is manufactured of the same material as the flexible solder mask portion of the first layer 602. In an alternate example, the flexible solder

mask portion is made from a different material than the flexible solder mask in the first layer 602. In an alternate example, a second signal return layer (not shown) may be positioned in the dielectric material.

To eliminate crosstalk caused by adjacent traces, each trace 422, 424, 426, 428, 430, 432, 434 and 436 is electrically coupled to an adjacent trace 422, 424, 426, 428, 430, 432, 434 and 436. As an illustrative example, trace 422 may be coupled to trace 424. During operation, a first signal is transmitted down a first trace and an identical signal having an opposite polarity is transmitted down the matched trace thereby differentially coupling the traces together. Because the traces are differentially coupled together, the impedance of each trace determines how the trace is driven. Accordingly, the impedance of each set of matched trace should be substantially equal.

The physical characteristics of each trace 422, 424, 426, 428, 430, 432, 434 and 436 in a matched set of traces are adjusted to balance the impedance between the matched traces for the transmission and return signals transmitted over each trace. The impedance of each trace 422, 424, 426, 428, 430, 432, 434 and 436 is adjusted by adjusting any one or a combination of the length (L), width (W), height (H) of each trace and the spacing (S) between the matched traces for each signal transmitted through each trace 422, 424, 426, 428, 430, 432, 434 and 436. The height (H) of each trace 422, 424, 426, 428, 430, 432, 434 and 436 may be between approximately 2 mils and approximately 6 mils, and the spacing (S) between adjacent traces 422, 424, 426, 428, 430, 432, 434 and 436 may be between approximately 3 mils and approximately 10 mils.

Returning to FIG. 4, each trace has a variable width in the first portion 454, 456, 458, 460, 462, 464, 466 and 468 and a substantially constant width in the second portion 470, 472, 474, 476, 478, 480 and 482. Accordingly, the width of each trace 422, 424, 426, 428, 430, 432, 434 and 436 is adjusted in either the first portion 454, 456, 458, 460, 462, 464, 466 and 468 or the second portion 470, 472, 474, 476, 478, 480 and 482, or in both the first portion 454, 456, 458, 460, 462, 464, 466 and 468 and the second portion to 470, 472, 474, 476, 478, 480 and 482 along with the height H of the trace 422, 424, 426, 428, 430, 432, 434 and 436, such that each trace in a matched set has substantially the same impedance when the matched traces are separated by a distance S.

Due to inconsistencies in manufacturing and materials, the signal driven through each set of differentially matched traces 422, 424, 426, 428, 430, 432, 434 and 436 may not be identical, which causes a portion of the signal to reflect back causing common mode interference. To eliminate any common mode interference, each trace 422, 424, 426, 428, 430, 432, 434 or 436 in a matched set of traces includes a common mode filter that is tuned to eliminate any common mode interference in the matched set. Each filter is comprised of a capacitor formed by the via 406, 408, 410, 412, 414, 416, 418 or 420 of each trace 422, 424, 426, 428, 430, 432, 434 or 436 and the fourth layer 608 of the multi-layer substrate 402. Each via 406, 408, 410, 412, 414, 416, 418 and 420 includes a layer of conductive material, such as gold or copper, formed around the periphery the via 406, 408, 410, 412, 414, 416, 418 and 420 on the second layer 604 and fourth layer 608 of the substrate 402. The conductive material on the first layer 602 is connected to the trace 422, 424, 426, 428, 430, 432, 434 or 436 associated with the via 406, 408, 410, 412, 414, 416, 418 and 420 and the conductive material on the fourth layer 608 is connected to the signal return portion of the fourth layer 608. The size of each

capacitor is determined by the distance between the conductive material on the second layer **604** and the fourth layer **608**. Accordingly, adjusting the depth of the third layer **606** in relation to the conductive material on the vias **406**, **408**, **410**, **412**, **414**, **416**, **418** and **420**, allows for the capacitive effect of each via **406**, **408**, **410**, **412**, **414**, **416**, **418** and **420** to be adjusted. The capacitors created by the via **406**, **408**, **410**, **412**, **414**, **416**, **418** and **420** and return portion of the fourth layer **608** are sized between approximately 0.1 picofarads (pf) to approximately 0.5 pf. The top and bottom surfaces of the substrate **402** may be covered in a plastic insulating layer to further enhance the operation of the circuit.

The combination of the capacitor created in each via **406**, **408**, **410**, **412**, **414**, **416**, **418** and **420** and the characteristic inductance of the signal return layer creates a common mode filter for each trace **422**, **424**, **426**, **428**, **430**, **432**, **434** or **436**. By adjusting the capacitive value of each capacitor based on the impedance of the trace **422**, **424**, **426**, **428**, **430**, **432**, **434** and **436**, common mode noise is greater reduced, thereby improving the signal throughput on each trace **422**, **424**, **426**, **428**, **430**, **432**, **434** and **436**.

FIG. 6B illustrates a schematic representation of a cross sectional view of a via **406**, **408**, **410**, **412**, **414**, **416**, **418** or **420**. Each via **406**, **408**, **410**, **412**, **414**, **416**, **418** and **420** is formed through the first layer **602**, second layer, **604**, third layer **606**, fourth layer **608** and fifth layer **610**. The second layer **604** is made of a conductive material, such as gold or copper and surrounds the circumference of each via **406**, **408**, **410**, **412**, **414**, **416**, **418** and **420**. The second layer **604** also connects each via **406**, **408**, **410**, **412**, **414**, **416**, **418** and **420** to its respective trace **422**, **424**, **426**, **428**, **430**, **432**, **434** or **436**. The third layer **606** acts as a dielectric layer as described in FIG. 6A. The fourth layer **608** is formed in the third layer **606** and acts as a signal return layer. The fifth layer **610** is also made from a conductive material such as copper or gold, and also surrounds the circumference of the via in the same manner as the second layer **602**. A sealing layer (not shown) may also be formed over the fifth layer **610**.

The fourth layer **608** is separated from the second layer **604** by a distance D1 and from the fifth layer **610** by a second distance D2. The combination of the second layer **604**, third dielectric layer **606**, and the fourth return signal layer **608** creates a capacitor having a capacitive value of between approximately 0.1 pf and 0.5 pf. By adjusting the distance D1 of the fourth layer **608** from the second layer **604**, the capacitive value of the via capacitor is adjusted. Because the via connects its associated trace with the fourth return signal layer **608**, the combination of second layer **604**, the third dielectric layer **606**, and the fourth return signal layer **608** forms a common mode filter that removes any interference caused by signal reflection resulting from imperfections in the manufacturing process. By adjusting the capacitive value of the via capacitor the common mode filter may be tuned to eliminate substantially all signal noise caused by reflection of the transmission or return signal.

FIG. 6C illustrates another example of cross sectional view of a via **406**, **408**, **410**, **412**, **414**, **416**, **418** and **420**. A second return signal layer **612** is added to the third layer **606** between the first return signal layer **608** and the fifth layer **610**. The second return signal layer **612** runs parallel to the first signal layer **608** and enhances the filtering effect of the common mode filter. By adjusting a distance D3 between the first return signal layer **608** and the second return signal layer **612**, a second capacitor formed by the first return signal layer **608**, third layer **606** and second return signal

layer **612** is created in the via. By adjusting the distance D3, the value of the second via capacitor may be adjusted to enhance the operation of the common mode filter. Further, as the inventors have learned, forming a second capacitor in the via allows for matching of traces on separate ends of the PCB **102**. As an illustrative example, trace **422** may be matched with trace **436**. Accordingly, by forming the second capacitor, pairs of signal lines positioned in accordance with the RJ 45 standard can be achieved.

FIG. 7 illustrates a schematic representation an RJ 45 jack having matched transmit and receive traces. By adjusting the height H, width W, and length L of each trace **422**, **424**, **426**, **428**, **430**, **432**, **434** or **436** transmit and a receive lines can be impedance matched. To enhance the operation of the jack, identical high frequency signals having opposite polarities are transmitted down each pair. Because the matched traces are coupled via the shield, the pairs act as common mode filters for each other. Also, if one signal cannot be delivered, the corresponding opposite signal line will deliver the identical signal. Because the matched traces act as filters coupled to the shield, noise caused by high bandwidth transmission are filtered out from the signal. Further, because the transmit line is matched with the receive line, filtering of the signal is performed with greater accuracy because the reference point for the filters is the signal itself, opposed to being a ground connection.

FIG. 8 illustrates a schematic representation of a differentially balanced pair of signal lines. As the figure depicts, the characteristics of each trace is adjusted such that the impedance of a first trace is matched to the impedance of the second trace using the methods previously discussed. Further, the capacitors formed in each via form a common mode filter with a return signal line embedded in the PCB **120**. By differentially balancing two traces during transmission of both the transmission and response signals, a fully balanced two way communication circuit is achieved.

FIG. 9 illustrates a schematic representation of a method of balancing matched traces for a transmission and return signal. In step **902**, physical characteristics of each trace in a matched pair of traces are adjusted such that the impedance of the traces are substantially equal. The physical characteristics may include the height, length and width of each trace and the distance separating each trace in the matched set of traces. In step **904**, a first signal having a first polarity is transmitted down the first trace in the match set traces. The first signal may be a high frequency communication signal operating at a frequency greater than 10 gigahertz ("GHz"). In step **906**, a second signal substantially identical to the first signal and having a polarity opposite to the polarity of the first signal is transmitted on the second trace of the match set of traces simultaneously with the first signal. In step **908**, the first signal is measured at the generation and termination end of the trace, and the two measurements are compared to determine the amount of data lost along the length of the trace. In step **910**, at least one physical characteristic of the first trace or second trace is adjusted based on the amount of signal loss measured. The process may return to step **904** until the amount of signal loss is less than approximately 10 decibels ("db").

In step **912**, a third signal is transmitted on the second trace of the matched set of traces. In step **914**, a fourth signal substantially identical to the third signal but having a polarity opposite the polarity of the third signal is transmitted on the first trace. In step **916**, the third signal is measured at the generation and termination end of the trace, and the two measurements are compared to determine the amount of data lost along the length of the trace. In step **918**, at least

11

one physical characteristic of the first trace or second trace is adjusted based on the amount of signal loss measured. The process may return to step **912** until the amount of signal loss is less than approximately 10 decibels (“db”). In another example, the process may return to step **904** to confirm the signal loss of the first signal is not affected by the adjustments made in response to the third signal loss.

FIG. **10** illustrates the PCB **120** positioned in the jack **110**. The substrate **402** of the PCB **120** is made from a flexible material that allows a first portion of the PCB **120** to be oriented to a second portion of the PCB **120** by approximately a 90 degree angle. Accordingly, the PCB **120** is bent such that the vias **406, 408, 410, 412, 414, 416, 418** and **420** are positioned over the pins **210** in the jack, and the traces **422, 424, 426, 428, 430, 432, 434** and **436** extend from the vias **406, 408, 410, 412, 414, 416, 418** and **420** to the contact pads for the jack. The shielding tabs **486** and **488** are bent such that they are at approximately a 90 degree angle from the PCB **120**. The shielding tabs **486** and **488** are positioned along the side of the jack such that the jack shield **130** of the jack engages the shielding tabs **486** and **488**.

The flexible PCB **120** may be implemented using any flexible plastic substrates that enable the flexible PCB **120** to bend. As described herein, the flexible PCB **120** may flex or bend to conform to the existing form factor of the RJ45 jack **110** and be shielded by the jack shielding **130**. For example, the flexible PCB **120** may be attached to the RJ45 jack **110**, placed between the RJ45 jack **110** and the jack shield **130**. The flexible PCB **120** shielding tabs **486** and **488** may be attached to the jack shield **130** to provide a common connection to the flex circuit on the flexible PCB **120**. The set of pins **210** of the RJ45 jack **110** may then be electrically coupled to a circuit board of a device in which the RJ45 jack **110** is used.

The flexible PCB **120** may be configured to fold and conform to the shape of the RJ45 jack **110** for better fit into an existing enclosure such as the jack shield **130**. For example, in one aspect of the disclosed approach, the flexible PCB **120** bends at an approximately 90 degree angle towards a middle section of the flexible PCB **120**, to fold into the jack shield **130**. The shielding tabs **486** and **488** of the flexible PCB **120** are folded onto and contacting the jack shield **130**, may be soldered to secure the flexible PCB **120** to the jack shield **130**. Those skilled in the art will recognize that the orientation of the flexible PCB **120** with respect to the RJ45 jack **110** within the jack shield **130** may vary in accordance with various aspects of the disclosure. For example, the flexible PCB **120** may be sufficiently thin to flex and fold into other sides of the jack shield **130**. The flexible PCB **120** may be shaped to lie entirely along the bottom section **304** of the jack shield **130** without needing to flex or bend into the jack shield **130**.

The preceding detailed description is merely some examples and embodiments of the present disclosure and that numerous changes to the disclose embodiments can be made in accordance with the disclosure herein without departing from its spirit or scope. The preceding description, therefore, is not meant to limit the scope of the disclosure but to provide sufficient disclosure to one of ordinary skill in the art to practice the invention with undue burden.

The invention claimed is:

1. A high speed communication jack comprising:

a housing including a port for accepting a plug, the port including a plurality of pins each connected to a corresponding signal line in the plug;

12

a shielding case surrounding the housing;  
a circuit board disposed in part between the shielding case and the housing, wherein the circuit board comprises a substrate having a first side and a second side opposite the first side,

a plurality of pin vias extending through the substrate where each of the pin vias is configured to accommodate a pin on the housing,

a plurality of traces on the first side of the substrate where each trace extends from a corresponding one of the plurality of pin vias;

a shielding trace layer disposed on the first side of the substrate including a pair of shielding tabs disposed on opposite edges of the first side of the substrate and a shielding trace disposed on the first side of the substrate opposite the first plurality of pin vias where the shielding trace extends between and connects the shielding tabs,

a shielding plane on the second side of the substrate,  
a plurality of return vias extending through the substrate with each of the return vias connecting the shielding trace layer and the shielding plane,

wherein, a height, width, length and spacing of at least two traces are adjusted such that an impedance of the at least two traces is substantially the same.

2. The high speed communication jack of claim 1, wherein each trace includes a first portion having a variable width and a second portion having a substantially contact width.

3. The high speed communication jack of claim 2, wherein the first portion is disposed non-coplanar with the second portion.

4. The high speed communication jack of claim 1, wherein the shielding plane engages the shielding case.

5. The high speed communication jack of claim 1, wherein a capacitor is formed by a coating surrounding a periphery of each pin via and the shielding layer.

6. The high speed communication jack of claim 5, wherein a distance between the shielding layer and the traces is adjusted such that the capacitor has a value of between approximately 0.1 pf and approximately 0.5 pf.

7. A circuit board for a high speed communication jack having a housing with a shielding case, the circuit board disposed between the housing and the shielding case comprising:

a substrate having a first side and a second side opposite the first side,

a plurality of pin vias extending through the substrate where each of the pin vias is configured to accommodate a pin on the housing,

a plurality of traces on the first side of the substrate where each trace extends from a corresponding one of the plurality of pin vias;

a shielding trace layer disposed on the first side of the substrate including a pair of shielding tabs disposed on opposite edges of the first side of the substrate and a shielding trace disposed on the first side of the substrate opposite the first plurality of pin vias where the shielding trace extends between and connects the shielding tabs,

a shielding plane on the second side of the substrate,  
a plurality of return vias extending through the substrate with each of the return vias connecting the shielding trace layer and the shielding plane,

wherein, the substrate is non-coplanar and a height, width, length and spacing of at least two traces are adjusted such that an impedance of the at least two traces is substantially the same.



8. The circuit board of claim 7, wherein a capacitor is formed by a coating surrounding a periphery of each pin via and the shielding layer.

9. The circuit board of claim 8, wherein a distance between the shielding layer and the traces is adjusted such that the capacitor has a value of between approximately 0.1 pf and approximately 0.5 pf. 5

10. The circuit board of claim 7, wherein the substrate comprises a dielectric material having a dielectric constant greater than 3.0. 10

\* \* \* \* \*